

Incremental encoders

Hollow or end shaft max. $\varnothing 25.4$ mm

Resolution 1024...16384 pulses

G110H, G110S



G110H with hollow shaft

Features

- Encoder with end or hollow shaft max. $\varnothing 25.4$ mm
- Resolution max. 16384 ppr
- Optical sensing
- Robust design
- High resistance to shock and vibrations
- High signal quality

Technical data - electrical ratings

Voltage supply	5 VDC ± 10 % 4.75...30 VDC
Reverse polarity protection	Yes (4.75...30 VDC)
Consumption w/o load	≤ 30 mA (24 VDC) ≤ 60 mA (5 VDC)
Resolution (steps/turn)	1024...16384
Reference signal	Zero pulse, width 90°
Sensing method	Optical
Output frequency	≤ 150 kHz
Output signals	A 90° B, N + inverted
Output circuit	Linedriver/RS422 Push-pull short-circuit proof
Interference immunity	DIN EN 61000-6-2
Emitted interference	DIN EN 61000-6-4
Approval	UL approval / E63076

Technical data - mechanical design

Dimensions (flange)	$\varnothing 75$ mm
Protection DIN EN 60529	IP 54
Operating speed	≤ 3800 rpm
Rotor moment of inertia	2000 gcm ²
Materials	Housing: aluminium Flange: aluminium
Operating temperature	-25...+85 °C (24 VDC) -40...+85 °C (optional)
Relative humidity	95 % non-condensing
Resistance	DIN EN 60068-2-6 Vibration 10 g, 16-2000 Hz DIN EN 60068-2-27 Shock 200 g, 6 ms
Connection	Connector M23, 12-pin
Weight approx.	700 g

G110H

Shaft	$\varnothing 20$ mm hollow shaft $\varnothing 25$ mm hollow shaft $\varnothing 25.4$ mm hollow shaft
-------	--

G110S

Shaft	$\varnothing 20$ mm end shaft $\varnothing 25$ mm end shaft
-------	--

Incremental encoders

Hollow or end shaft max. $\varnothing 25.4$ mm
Resolution 1024...16384 pulses

G110H, G110S

Part number

Hollow shaft

G110H. C3

See part number (pulses)

Connection

C3 Connector M23, 12-pin, radial

Voltage supply / signals

22 5 VDC / linedriver RS422 (≤ 6000 pulses)
25 5 VDC / linedriver RS422 (> 6000 pulses)
70 4.75...30 VDC / push-pull (≤ 6000 pulses)
75 4.75...30 VDC / push-pull (> 6000 pulses)

Hollow shaft / torque pin

- H Hollow shaft $\varnothing 20$ mm clamping ring on flange without pin
- 1 Hollow shaft $\varnothing 20$ mm clamping ring on flange with pin 15 mm
- G Hollow shaft $\varnothing 25$ mm clamping ring on flange without pin
- 2 Hollow shaft $\varnothing 25$ mm clamping ring on flange with pin 15 mm
- F Hollow shaft $\varnothing 25$ mm clamping ring on housing without pin
- 5 Hollow shaft $\varnothing 25$ mm clamping ring on housing with pin 15 mm
- 0 Hollow shaft $\varnothing 25.4$ mm clamping ring on housing without pin
- A Hollow shaft $\varnothing 25.4$ mm clamping ring on housing with pin 15 mm

Part number (pulses)

23 (1024)	30 (2500)	35 (5000)	73 (10000)
29 (2048)	34 (4096)	70 (8192)	71 (16384)

Other pulse numbers upon request.
Example: order key 35 = 5000 pulses.

End shaft

G110S. C3

See part number (pulses)

Connection

C3 Connector M23, 12-pin, radial

Voltage supply / signals

22 5 VDC / linedriver RS422
70 4.75...30 VDC / push-pull

Hollow shaft / torque pin

- H End shaft $\varnothing 20$ mm clamping ring on flange without pin
- 1 End shaft $\varnothing 20$ mm clamping ring on flange with pin 15 mm
- G End shaft $\varnothing 25$ mm clamping ring on flange without pin
- 2 End shaft $\varnothing 25$ mm clamping ring on flange with pin 15 mm

Accessories

Connectors and cables

Z 141.001	Female connector M23, 12-pin, less cable
Z 141.003	Female connector M23, 12-pin, 2 m cable
Z 141.005	Female connector M23, 12-pin, 5 m cable
Z 141.007	Female connector M23, 12-pin, 10 m cable

Mounting accessories

Z 119.041	Torque support by rubber buffer element for encoders with 15 mm pin
Z 119.043	Spring coupling for GX and G1
Z 119.050	Spring coupling

Incremental encoders

Hollow or end shaft max. $\varnothing 25.4$ mm

Resolution 1024...16384 pulses

G110H, G110S

Output signals

Clockwise rotating direction when looking at flange.

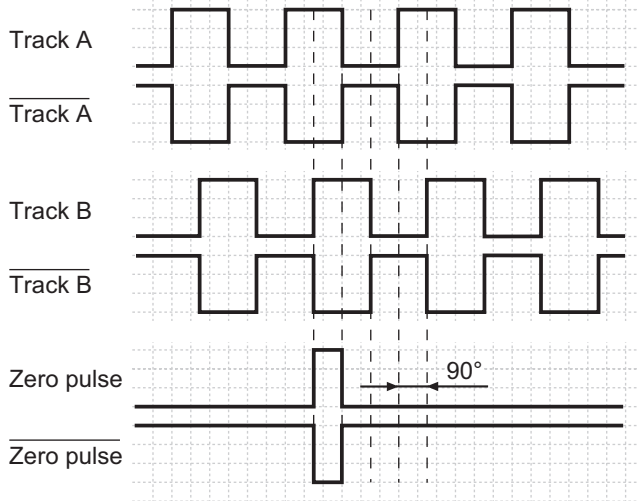

Terminal assignment

Connector	Assignment
Pin 1	Track B inv.
Pin 2	UB-Sense
Pin 3	Track N (zero pulse)
Pin 4	Track N inv. (zero pulse inv.)
Pin 5	Track A
Pin 6	Track A inv.
Pin 7	–
Pin 8	Track B
Pin 9	–
Pin 10	GND
Pin 11	GND-Sense
Pin 12	UB

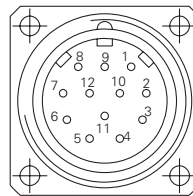

UB-Sense and GND-Sense are directly connected to UB resp. GND. Please use cores twisted in pairs (for example track A / track A inv.) for extension cables of more than 10 m length.

Trigger level

Outputs	Linedriver RS422
Output level High	>2.5 V (I = -20 mA)
Output level Low	<0.5 V (I = 20 mA)
Load High	<20 mA
Load Low	<20 mA

Outputs	Push-pull short-circuit proof
Output level High	>UB -3 V (I = -20 mA)
Output level Low	<0.5 V (I = 20 mA)
Load High	<20 mA
Load Low	<20 mA

Incremental encoders

Hollow or end shaft max. $\varnothing 25.4$ mm
Resolution 1024...16384 pulses

G110H, G110S

Dimensions

G110H - hollow shaft, clamping ring on flange

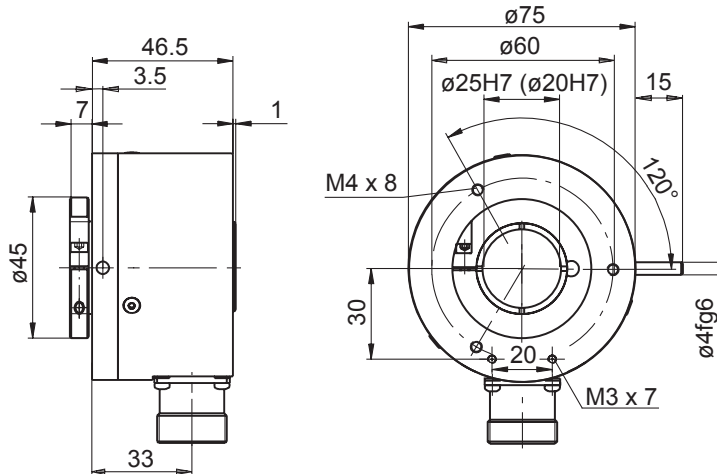

G110H - hollow shaft, clamping ring on housing

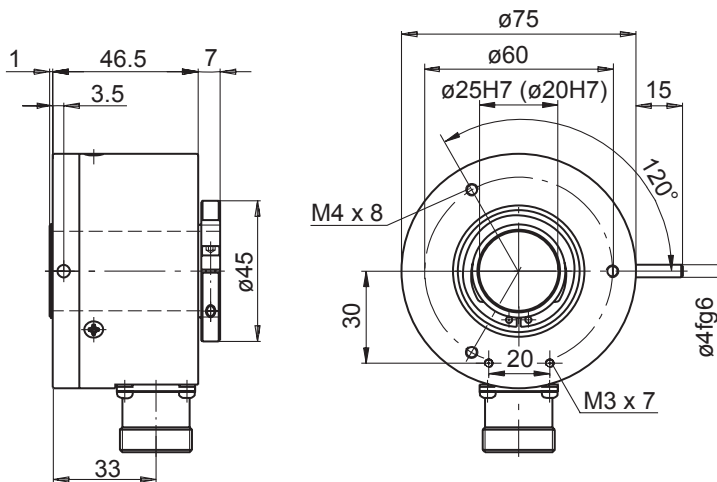

G110S - end shaft, clamping ring on flange

