

## General Description

The AAT4618 SmartSwitch is a member of Skyworks' Application Specific Power MOSFET™ (ASPM™) product family. It is a current limited P-channel MOSFET power switch designed for high-side load switching applications operating with inputs ranging from 2.4V to 5.5V, making it ideal for 2.5V, 3V, and 5V systems. An integrated current-limiting circuit protects the input supply from large currents which may cause the supply to fall out of regulation. In addition, the AAT4618 thermal overload protection limits power dissipation and junction temperatures associated with prolonged periods of operation in current limit. Due to its low  $R_{DS(ON)}$ , the AAT4618 can be used to control loads that require up to factory preset 400mA, 500mA, or 1A. The ultra-fast current limit response to a sudden short circuit is a mere 400ns which reduces the requirements of local supply bypassing. An open drain FAULT flag signals an over-current or over-temperature condition after a 4ms timeout. Quiescent current is a low 10 $\mu$ A and the supply current decreases to less than 1 $\mu$ A in shutdown mode.

The AAT4618 is available in a Pb-free 5-pin SOT-23 or a 8-pin SC70JW package and is specified over the -40°C to +85°C temperature range.

The AAT4600 series is a family of adjustable and fixed voltage SmartSwitch products with a range of current handling capabilities. Single versions with adjustable current limit (AAT4610, AAT4601) or fixed current limit (AAT4625) are available, as well as dual versions with fixed current limit (AAT4626, AAT4670).

## Features

- 2.4V to 5.5V Input Voltage Range
- Current Limit Trip Threshold Options:
  - 400mA Min
  - 500mA Min
  - 1A Min
- Fast Transient Response:
  - 400ns Response to Short Circuit
- Low Quiescent Current:
  - 10 $\mu$ A Typical
  - < 1 $\mu$ A with Switch Off
- 125m $\Omega$  Typical  $R_{DS(ON)}$
- FAULT Flag with 4ms Blanking
- Under-Voltage Lockout
- Thermal Shutdown
- Temperature Range: -40°C to +85°C
- 4kV ESD Rating
- 5-Pin SOT23 or 8-Pin SC70JW Package

## Applications

- Hot Swap Supplies
- Notebook Computers
- Peripheral Ports
- Personal Communication Devices
- USB Ports

## Typical Application

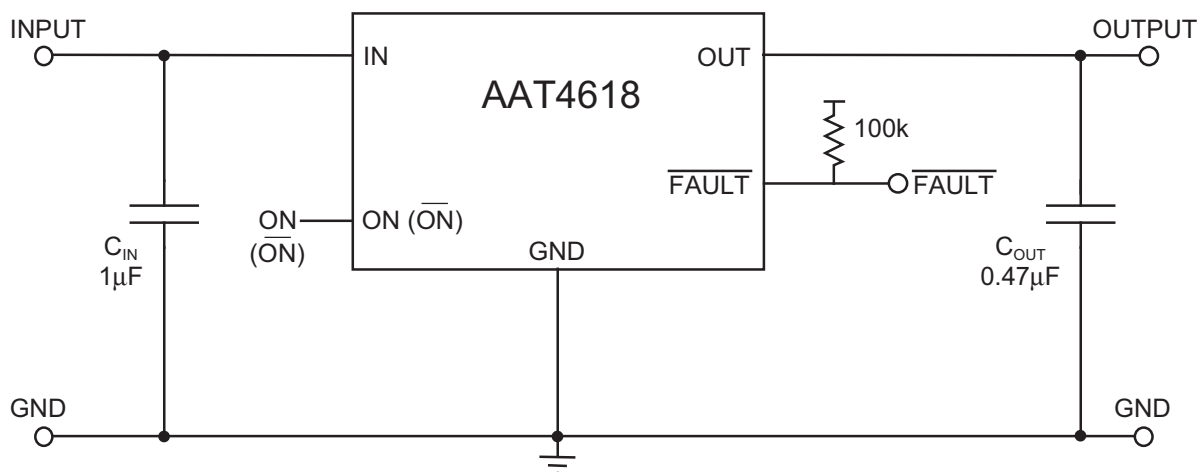

# AAT4618

## Current Limited Load Switch

### Pin Descriptions

Pin #		Symbol	Function
SOT23-5	SC70JW-8		
1	5	OUT	P-channel MOSFET drain.
2	6, 7, 8	GND	Ground connection.
3	1	$\overline{\text{FAULT}}$	Open-drain FAULT output.
4	2	ON ( $\overline{\text{ON}}$ )	Enable input: AAT4618 active low, AAT4618-1 active high.
5	3, 4	IN	P-channel MOSFET source.

### Pin Configuration

SOT23-5  
(Top View)

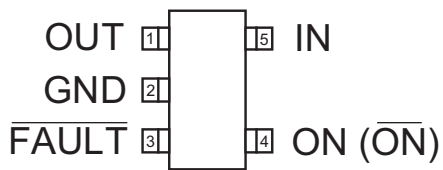

SC70JW-8  
(Top View)

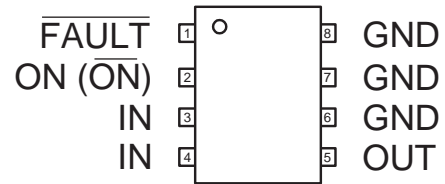

### Absolute Maximum Ratings<sup>1</sup>

$T_A = 25^\circ\text{C}$ , unless otherwise noted.

Symbol	Description	Value	Units
$V_{IN, FAULT}$	IN, $\overline{FAULT}$ to GND	-0.3 to 6	V
$V_{ON}$	ON ( $\overline{ON}$ ) to GND	-0.3 to $V_{IN} + 1$	V
$V_{OUT}$	OUT to GND	-0.3 to $V_{IN} + 0.3$	V
$I_{OUT}$	Output Current	Internally Limited	A
$T_J$	Operating Junction Temperature Range	-40 to 150	$^\circ\text{C}$
$V_{ESD}$	ESD Rating <sup>2</sup> —HBM	4000	V
$T_{LEAD}$	Maximum Soldering Temperature (at Leads)	300	$^\circ\text{C}$

### Thermal Characteristics<sup>3</sup>

Symbol	Description	Value	Units
$\Theta_{JA}$	Maximum Thermal Resistance	150	$^\circ\text{C}/\text{W}$
$P_D$	Maximum Power Dissipation	667	mW

1. Stresses above those listed in Absolute Maximum Ratings may cause permanent damage to the device. Functional operation at conditions other than the operating conditions specified is not implied. Only one Absolute Maximum Rating should be applied at any one time.
2. Human body model is a 100pF capacitor discharged through a 1.5k $\Omega$  resistor into each pin.
3. Mounted on a demo board.

## Electrical Characteristics

$V_{IN} = 5V$ ,  $T_A = -40^{\circ}C$  to  $+85^{\circ}C$ , unless otherwise noted. Typical values are  $T_A = 25^{\circ}C$ ; **bold** values denote full temperature range.

Symbol	Description	Conditions	Min	Typ	Max	Units	
$V_{IN}$	Operation Voltage		2.4		5.5	V	
$I_Q$	Quiescent Current	$V_{IN} = 5V$ , ON ( $\overline{ON}$ ) = Active, $I_{OUT} = 0$		10	<b>25</b>	$\mu A$	
$I_{Q(OFF)}$	Off Supply Current	ON ( $\overline{ON}$ ) = Inactive, $V_{IN} = 5.5V$			<b>1</b>		
$I_{SD(OFF)}$	Off Switch Current	ON ( $\overline{ON}$ ) = Inactive, $V_{IN} = 5.5V$ , $V_{OUT} = 0$		0.1	<b>1</b>		
$V_{UVLO}$	Under-Voltage Lockout	$V_{IN}$ Falling		1.9		V	
$V_{UVLO(hys)}$	Under-Voltage Lockout Hysteresis			0.3			
$R_{DS(ON)}$	On Resistance	$V_{IN} = 5.0V$ , $T_A = 25^{\circ}C$		125	175	$m\Omega$	
		$V_{IN} = 3.0V$ , $T_A = 25^{\circ}C$		155	225		
$TC_{RDS}$	On Resistance Temperature Coefficient			2800		ppm/ $^{\circ}C$	
$I_{LIM}$	Current Limit	$V_{OUT} = V_{IN}$ to 0.5V	AAT4618-0.4	400	500	600	$mA$
			AAT4618-0.5	500	750	1000	
			AAT4618-1.0	1000	1500	2000	
$V_{ON(L)}$	ON ( $\overline{ON}$ ) Input Low Voltage	$V_{IN} = 2.7V$ to $5.5V^1$			<b>0.8</b>	V	
$V_{ON(H)}$	ON ( $\overline{ON}$ ) Input High Voltage	$V_{IN} = 2.7V$ to $\leq 4.2V^1$	<b>2.0</b>				
		$V_{IN} = > 4.2V$ to $5.0V^1$	<b>2.4</b>				
$I_{ON(SINK)}$	ON ( $\overline{ON}$ ) Input Leakage	$V_{ON(\overline{ON})} = 5.5V$		0.01	<b>1</b>	$\mu A$	
$t_{RESP}$	Current Loop Response	$V_{IN} = 5V$		400		ns	
$T_{OFF}$	Turn-Off Time	$V_{IN} = 5V$ , $R_L = 20\Omega$		5		$\mu s$	
$T_{ON}$	Turn-On Time	$V_{IN} = 5V$ , $R_L = 20\Omega$		1			
$V_{FAULTLOW}$	FAULT Logic Output Low	$I_{SINK} = 1mA$			<b>0.4</b>	V	
$I_{SINK}$	FAULT Logic Output High Leakage Current	$V_{FAULT} = 5.5V$		0.5	<b>1</b>	$\mu A$	
$T_{blank}$	FAULT Blanking Time			4		ms	
$T_{SD}$	Over-Temperature Threshold	$V_{IN} = 5V$		125		$^{\circ}C$	

1. For  $V_{IN}$  outside this range, consult Typical ON ( $\overline{ON}$ ) Threshold curve.

### Typical Characteristics

Unless otherwise noted,  $V_{IN} = 5V$ ,  $T_A = 25^\circ C$ .

**Quiescent Current vs. Temperature**

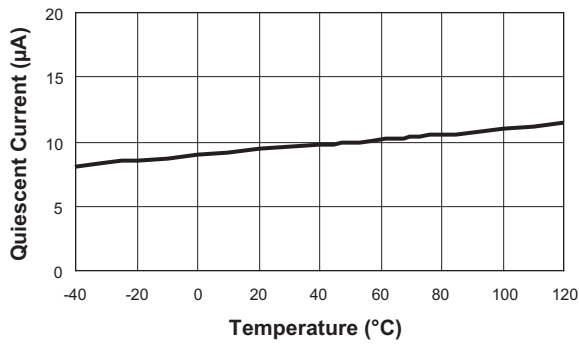

**Quiescent Current vs. Input Voltage**

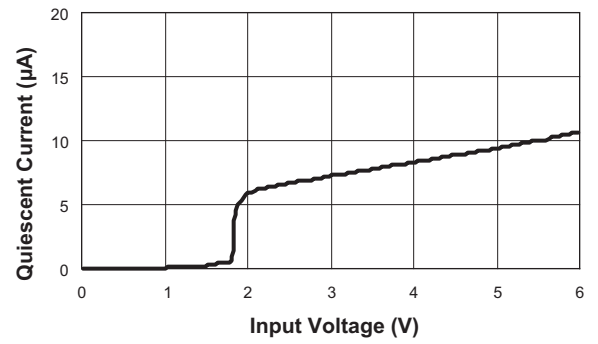

**Current Limit vs.  $V_{OUT}$**

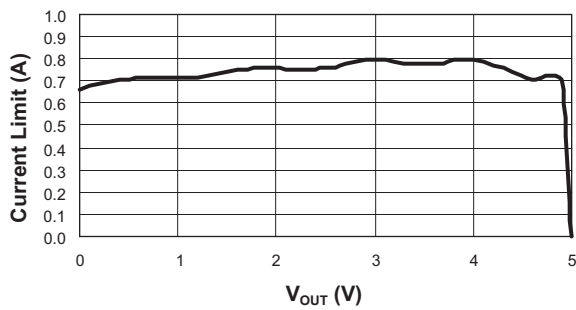

**$R_{DS(ON)}$  vs. Temperature**

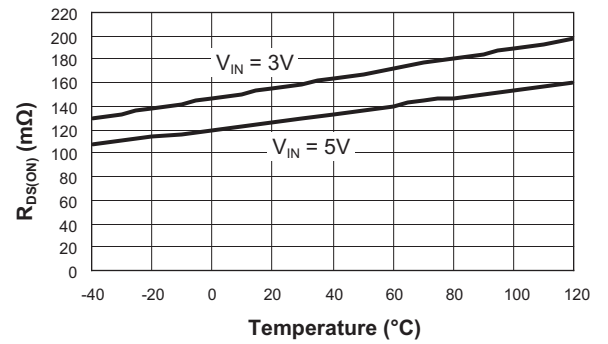

**Off-Supply Current vs. Temperature**

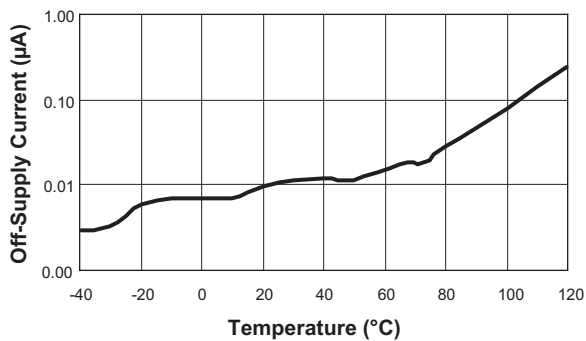

**Off-Switch Current vs. Temperature**

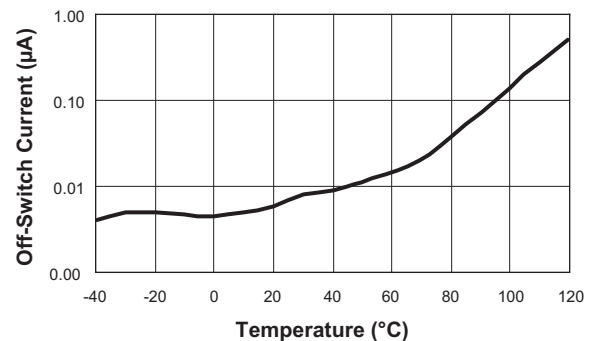

### Typical Characteristics

Unless otherwise noted,  $V_{IN} = 5V$ ,  $T_A = 25^\circ C$ .

**Turn-On**  
( $R_L = 20\Omega$ ;  $C_L = 0.47\mu F$ )

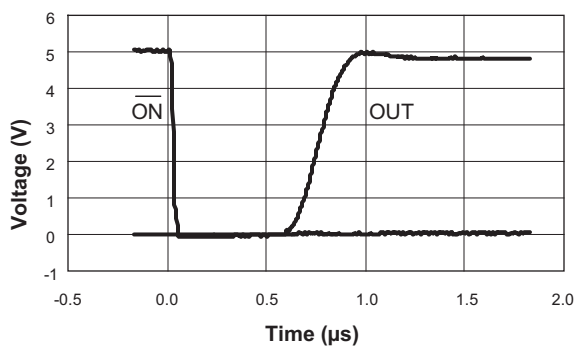

**Turn-Off**  
( $R_L = 20\Omega$ ;  $C_L = 0.47\mu F$ )

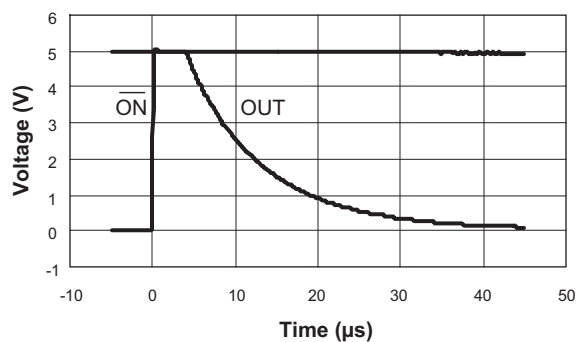

**Short Circuit Through 0.3Ω**

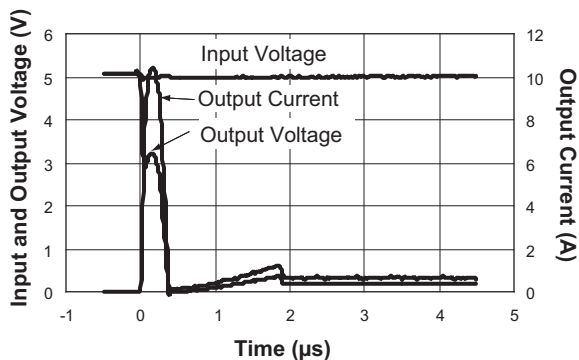

**Thermal Shutdown Response**

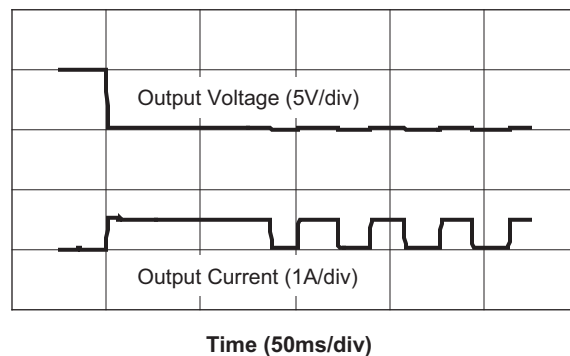

**Fault Delay from Short Circuit**

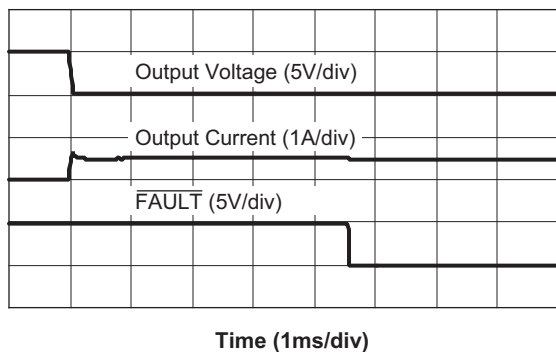

**ON ( $\overline{ON}$ ) Threshold vs. Input Voltage**

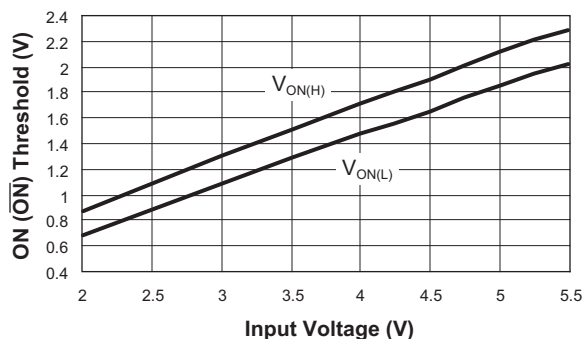

## Functional Block Diagram

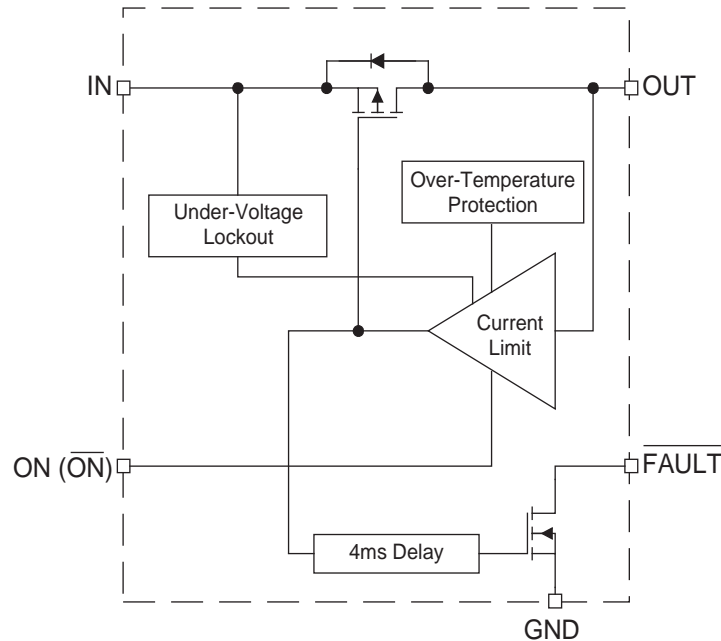

## Functional Description

The AAT4618 is a single channel current limited load switch that protects against short circuits by current limiting to a preset level. A patented fast-acting current limit loop limits the current in a fraction of a microsecond and instantly resets to low impedance once the short-circuit condition is removed. The AAT4618 is internally protected from thermal damage by an over-temperature detection circuit. If the die temperature reaches the internal thermal limit, the power device is switched off until the die temperature cools to a level below the thermal limit threshold. The device will thermal cycle indefinitely until the over-current condition is removed. The AAT4618 operates with input voltages ranging from 2.4V to 5.5V which, along with its extremely low operating current, makes it ideal for battery-powered applications. In cases where the input voltage drops below 2.4V, the AAT4618 MOSFET is protected from entering the saturated region of operation by being automatically shut down by an under-voltage lockout circuit. A current limit condition is reported by the open drain FAULT output. A 4ms blanking interval prevents false reporting during the charging of a capacitive load, which typically occurs during device turn-on, but may also occur during a port hot plug-in event.

The AAT4618 is ideally suited for protection of peripheral ports such as USB, RS232, and parallel ports.

## Applications Information

### Input Capacitor

The input capacitor  $C_{IN}$  protects the power supply from current transients generated by the load attached to the output of the AAT4618, a large current, limited only by the  $R_{DS(ON)}$  of the MOSFET, will flow for less than  $1\mu s$  before the current limit circuitry activates. (See characteristic curve "Short Circuit Through  $0.3\Omega$ .".) In this event, a moderately sized  $C_{IN}$  will dramatically reduce the voltage transient seen by the power supply and by other circuitry upstream from the AAT4618. The extremely fast short-circuit response time of the AAT4618 reduces the size requirement of  $C_{IN}$ .

$C_{IN}$  should be located as close to the device VIN pin as practically possible. Ceramic, tantalum, or aluminum electrolytic capacitors are appropriate for  $C_{IN}$ . There is no specific capacitor ESR requirement for  $C_{IN}$ . However, for higher current operation, ceramic capacitors are recommended for  $C_{IN}$  due to their inherent capability over tantalum capacitors to withstand input current surges from low impedance sources such as batteries in portable devices.

**Current Limited Load Switch**

**Output Capacitor**

In order to insure stability while current limit is active, a low capacitance (approximately 0.47μF) is required. No matter how large the output capacitor, output current is limited to the value set by the AAT4618 current limiting circuitry, so very large output capacitors can be used.

For example, USB ports are specified to have at least 120μF of capacitance downstream from their controlling power switch. The current limiting circuit will allow an output capacitance of 1000μF or more without disturbing the upstream power supply.

**ON (Enable Input)**

In many systems, power planes are controlled by integrated circuits which run at lower voltages than the power plane itself. The enable input (ON) of the AAT4618 has low and high threshold voltages that accommodate this condition. The threshold voltages are compatible with 5V TTL and 2.5V to 5V CMOS systems.

When switching the AAT4618 on into a capacitive load, the AAT4618 will charge the output capacitive load at a rate no greater than the current limit setting.

**Attaching Loads**

Capacitive loads attached to an enabled AAT4618 will charge at a rate no greater than the current limit setting.

**FAULT Output**

The FAULT flag is provided to alert the system if an AAT4618 load is not receiving sufficient voltage to operate properly. If current limit or over-temperature circuits in any combination are active for more than approximately 4ms, the FAULT flag is pulled to ground through approximately 100Ω. The filtering of voltage or current transients of less than 4ms prevents capacitive loads connected to the AAT4618 output from activating the FAULT flag when they are initially attached. Pull-up resistances of 1kΩ to 100kΩ are recommended. Since FAULT is an open drain terminal, it may be pulled up to any unrelated voltage less than the maximum operating voltage of 5.5V, allowing for level shifting between circuits.

**Thermal Considerations**

Since the AAT4618 has internal current limit and over-temperature protection, junction temperature is rarely a concern. However, if the application requires large currents in a hot environment, it is possible that temperature, rather than current limit, will be the dominant regulating condition. In these applications, the maximum current available without risk of an over-temperature condition must be calculated. The maximum internal temperature while current limit is not active can be calculated using Equation 1.

$$\text{Eq. 1: } T_{J(\text{MAX})} = I_{\text{MAX}}^2 \cdot R_{\text{DS(ON)(MAX)}} \cdot R_{\theta\text{JA}} + T_{\text{A(MAX)}}$$

In Equation 1,  $I_{\text{MAX}}$  is the maximum current required by the load.  $R_{\text{DS(ON)(MAX)}}$  is the maximum rated  $R_{\text{DS(ON)}}$  of the AAT4618 at high temperature.  $R_{\theta\text{JA}}$  is the thermal resistance between the AAT4618 die and the board onto which it is mounted.  $T_{\text{A(MAX)}}$  is the maximum temperature that the PCB under the AAT4618 would be if the AAT4618 were not dissipating power. Equation 1 can be rearranged to solve for  $I_{\text{MAX}}$ , as shown in Equation 2.

$$\text{Eq. 2: } I_{\text{MAX}} = \sqrt{\frac{T_{\text{SD(MIN)}} - T_{\text{A(MAX)}}}{R_{\text{DS(ON)(MAX)}} \cdot R_{\theta\text{JA}}}}$$

$T_{\text{SD(MIN)}}$  is the minimum temperature required to activate the AAT4618 over-temperature protection. With the typical specification of 125°C, 115°C is a safe minimum value to use.

For example, if an application is specified to operate in 50°C environments, the PCB operates at temperatures as high as 85°C. The application is sealed and its PCB is small, causing  $R_{\theta\text{JA}}$  to be approximately 150 °C/W. Using Equation 2,

$$\text{Eq. 3: } I_{\text{MAX}} = \sqrt{\frac{115 - 85}{220 \cdot 150}} = 950\text{mA}$$

The AAT4618 is safe to operate at the minimum current limit level of 500mA at 85°C.

## Ordering Information

Package	Enable	Current Limit	Marking <sup>1</sup>	Part Number (Tape and Reel) <sup>2</sup>
SOT23-5	Active Low	0.5	AVXYY	<b>AAT4618IGV-0.5-T1</b>
SOT23-5	Active High	0.5	DWXY Y	<b>AAT4618IGV-0.5-1-T1</b>
SOT23-5	Active Low	1.0	EVXYY	<b>AAT4618IGV-1.0-T1</b>
SOT23-5	Active High	1.0	EIXYY	<b>AAT4618IGV-1.0-1-T1</b>
SC70JW-8	Active Low	0.4		
SC70JW-8	Active High	0.4		
SC70JW-8	Active Low	0.5	AVXYY	<b>AAT4618IJS-0.5-T1</b>
SC70JW-8	Active High	0.5	DWXY Y	<b>AAT4618IJS-0.5-1-T1</b>
SC70JW-8	Active Low	1.0	EVXYY	<b>AAT4618IJS-1.0-T1</b>
SC70JW-8	Active High	1.0	EIXYY	<b>AAT4618IJS-1.0-1-T1</b>



Skyworks Green™ products are compliant with all applicable legislation and are halogen-free.



For additional information, refer to Skyworks *Definition of Green™*, document number SQ04-0074.

## Package Information

### SOT23-5

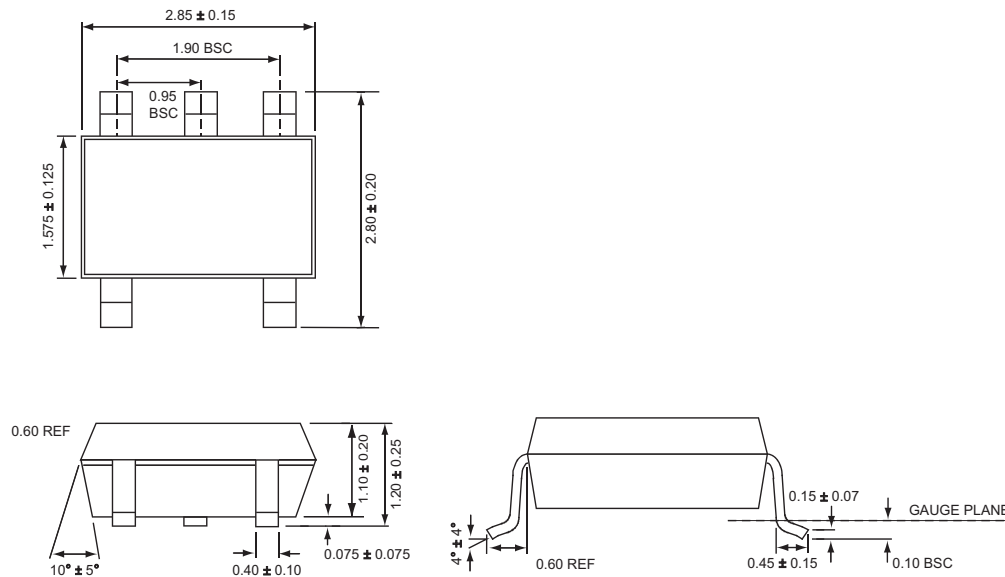

All dimensions in millimeters

1. XYY = assembly and date code.  
 2. Sample stock is generally held on all part numbers listed in **BOLD**.

SC70JW-8

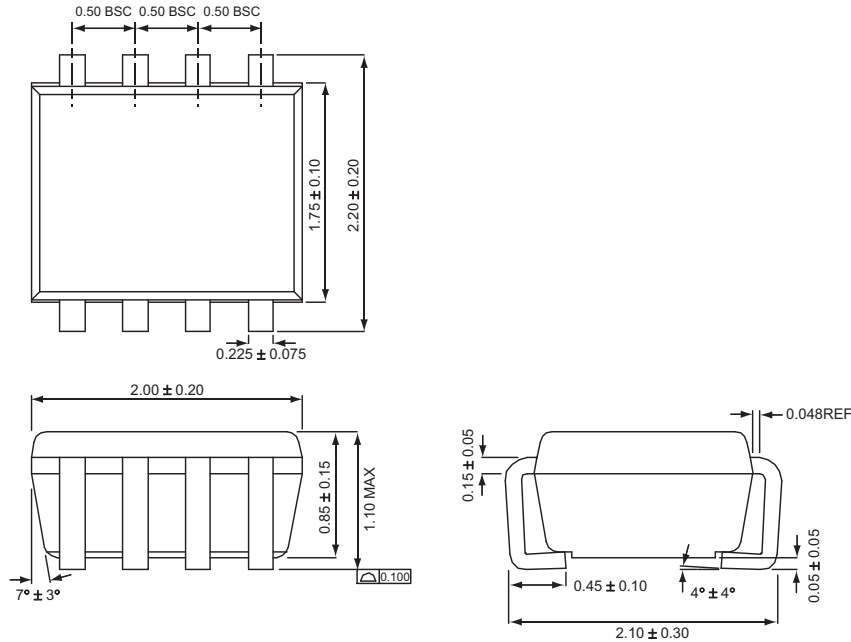

All dimensions in millimeters.

Copyright © 2012 Skyworks Solutions, Inc. All Rights Reserved.

Information in this document is provided in connection with Skyworks Solutions, Inc. ("Skyworks") products or services. These materials, including the information contained herein, are provided by Skyworks as a service to its customers and may be used for informational purposes only by the customer. Skyworks assumes no responsibility for errors or omissions in these materials or the information contained herein. Skyworks may change its documentation, products, services, specifications or product descriptions at any time, without notice. Skyworks makes no commitment to update the materials or information and shall have no responsibility whatsoever for conflicts, incompatibilities, or other difficulties arising from any future changes.

No license, whether express, implied, by estoppel or otherwise, is granted to any intellectual property rights by this document. Skyworks assumes no liability for any materials, products or information provided hereunder, including the sale, distribution, reproduction or use of Skyworks products, information or materials, except as may be provided in Skyworks Terms and Conditions of Sale.

THE MATERIALS, PRODUCTS AND INFORMATION ARE PROVIDED "AS IS" WITHOUT WARRANTY OF ANY KIND, WHETHER EXPRESS, IMPLIED, STATUTORY, OR OTHERWISE, INCLUDING FITNESS FOR A PARTICULAR PURPOSE OR USE, MERCHANTABILITY, PERFORMANCE, QUALITY OR NON-INFRINGEMENT OF ANY INTELLECTUAL PROPERTY RIGHT; ALL SUCH WARRANTIES ARE HEREBY EXPRESSLY DISCLAIMED. SKYWORKS DOES NOT WARRANT THE ACCURACY OR COMPLETENESS OF THE INFORMATION, TEXT, GRAPHICS OR OTHER ITEMS CONTAINED WITHIN THESE MATERIALS. SKYWORKS SHALL NOT BE LIABLE FOR ANY DAMAGES, INCLUDING BUT NOT LIMITED TO ANY SPECIAL, INDIRECT, INCIDENTAL, STATUTORY, OR CONSEQUENTIAL DAMAGES, INCLUDING WITHOUT LIMITATION, LOST REVENUES OR LOST PROFITS THAT MAY RESULT FROM THE USE OF THE MATERIALS OR INFORMATION, WHETHER OR NOT THE RECIPIENT OF MATERIALS HAS BEEN ADVISED OF THE POSSIBILITY OF SUCH DAMAGE.

Skyworks products are not intended for use in medical, lifesaving or life-sustaining applications, or other equipment in which the failure of the Skyworks products could lead to personal injury, death, physical or environmental damage. Skyworks customers using or selling Skyworks products for use in such applications do so at their own risk and agree to fully indemnify Skyworks for any damages resulting from such improper use or sale.

Customers are responsible for their products and applications using Skyworks products, which may deviate from published specifications as a result of design defects, errors, or operation of products outside of published parameters or design specifications. Customers should include design and operating safeguards to minimize these and other risks. Skyworks assumes no liability for applications assistance, customer product design, or damage to any equipment resulting from the use of Skyworks products outside of stated published specifications or parameters.

Skyworks, the Skyworks symbol, and "Breakthrough Simplicity" are trademarks or registered trademarks of Skyworks Solutions, Inc., in the United States and other countries. Third-party brands and names are for identification purposes only, and are the property of their respective owners. Additional information, including relevant terms and conditions, posted at [www.skyworksinc.com](http://www.skyworksinc.com), are incorporated by reference.