

Ultra High Precision Adjustable Current Limited Load Switch with Fault Flag

General Description

The AAT4616 SmartSwitch is a current limited P-channel MOSFET power switch designed for high side load switching applications. This switch operates with inputs ranging from 2.4V to 5.5V, making it ideal for both 3V and 5V systems. An integrated, highly accurate current-limiting circuit protects the input supply against large currents which may cause the supply to fall out of regulation. Reverse current blocking is provided to protect the load switch from reverse current flows while the device is in shutdown.

The AAT4616 is also protected from thermal overload which limits power dissipation and junction temperature. Current limit threshold is programmed with a resistor from SET to ground and may be adjusted for load levels up to 1.6A. The ultra-fast current limit response to a sudden short circuit is a mere 2μs which reduces the requirements of local supply bypassing. An open drain FAULT flag signals an over-current or over-temperature condition. To prevent false reporting, a 4ms time interval is used at startup (charging a capacitive load), where fault conditions are not monitored and reported. Quiescent current is a low 10μA and the supply current decreases to less than 1μA in shutdown mode.

The AAT4616 is offered in the small Pb-free, 5-pin SOT23-5 and TDFN22-8 packages, and is specified for operation over the -40°C to +85°C ambient temperature range.

Features

- Input Voltage Range: 2.4V to 5.5V
- Programmable Over-current Limit Setting
 - 300mA to 1.6A
- ±5% High Current Limit Precision at 750mA
- Fast Transient Response:
 - 2μs Response to Short Circuit
- Low Quiescent Current
 - 10μA Typical while Enabled
 - 1μA Max with Switch Off
- 130mΩ Typical $R_{DS(ON)}$
- Under-Voltage Lockout (UVLO)
- Reverse Blocking During Disable
- 4ms Fault Masking at Start-up (Capacitive Load)
- Fault Flag Open Drain Output
- Active Hi/Lo Enable Options
- Over Temperature Protection
- SOT23-5 and TDFN22-8 Package
- Temperature Range: -40°C to +85°

Applications

- USB Ports
- Portable Products
- Hot Swap Supplies
- Notebook Computers
- Proprietary Peripheral Ports

Typical Application

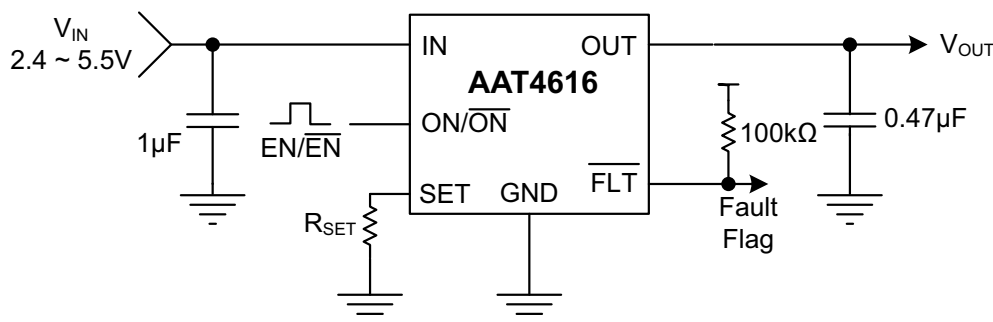

AAT4616

Ultra High Precision Adjustable Current Limited Load Switch with Fault Flag

Pin Descriptions

Pin #		Symbol	Description
SOT23-5	TDFN22-8		
1	7, 8	OUT	Current limiting load switch output (high side P-channel MOSFET Drain). Connect a 0.47 μ F capacitor from OUT to GND for best load transient response.
2	5	GND	IC Ground Connection
3	6	SET	Current limit set pin. Connect a resistor between this pin and ground to program the desired current limit set point.
4	3	ON/ $\overline{\text{ON}}$	Load switch enable input. Active high and active low options are available.
5	1, 2	IN	Load Switch Power Supply Input pin (high side P-channel MOSFET source). Bypass with a 1 μ F capacitor from IN to GND.
NA	4	$\overline{\text{FLT}}$	Current limit fault flag pin, open-drain output, active low signal. Pull up with a 10k Ω to 100k Ω resistor.

Pin Configuration

SOT23-5

(Top View)

TDFN22-8

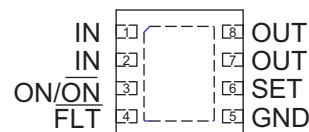
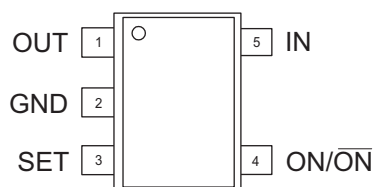

Ultra High Precision Adjustable Current Limited Load Switch with Fault Flag

Absolute Maximum Ratings¹

Symbol	Description	Value	Units
V_{IN}	IN to GND	-0.3 to 6	V
V_{ON}, V_{FLT}	ON/ \overline{ON} , \overline{FLT} to GND	-0.3 to $V_{IN} + 0.3$	
V_{SET}, V_{OUT}	SET, OUT to GND	-0.3 to $V_{IN} + 0.3$	
I_{MAX}	Maximum DC Output Current ²	2	A
T_J	Operating Junction Temperature Range	-40 to 150	°C
T_{STG}	Storage Temperature Range	-40 to 150	
T_{LEAD}	Maximum Soldering Temperature (at leads)	300	

Thermal Characteristics

Symbol	Package	Description	Value	Units
Θ_{JA}	TDFN22-8	Thermal Resistance	74	°C/W
	SOT23-5		220	
P_D	TDFN22-8	Power Dissipation ^{3,4}	1.35	W
	SOT23-5		0.45	

Recommended Operating Conditions

Symbol	Description	Min	Max	Unit
V_{IN}	Input Voltage	2.4	5.5	V
$V_{ON(H)}$	High-level Input Voltage	1.4		
$V_{ON(L)}$	Low-level Input Voltage		0.5	
T_A	Operating Temperature	-40	+85	°C

1. Stresses above those listed in Absolute Maximum Ratings may cause permanent damage to the device. Functional operation at conditions other than the operating conditions specified is not implied.

2. The current rating is based on long-term current density limitations.

3. Mounted on an FR4 board.

4. Derated 11.8 mW/°C above 25°C

Ultra High Precision Adjustable Current Limited Load Switch with Fault Flag**Electrical Characteristics**

$V_{IN} = 5V$, $T_A = -40^{\circ}C$ to $+85^{\circ}C$, unless otherwise noted. Typical values are at $T_A = 25^{\circ}C$.

Symbol	Description	Conditions	Min	Typ	Max	Units
V_{IN}	Input Voltage Range		2.4		5.5	V
I_Q	Operation Quiescent Current	$V_{IN} = 5V$, $ON/\overline{ON} = \text{Active}$, $I_{OUT} = 0$		10	25	μA
$I_{Q(OFF)}$	Off Supply Current	$ON/\overline{ON} = \text{Inactive}$, $V_{IN} = 5.5V$		0.01	1	
$I_{SD(OFF)}$	Off Switch Current	$ON/\overline{ON} = \text{Inactive}$, $V_{IN} = 5.5V$		0.01	1	
V_{UVLO}	Under-Voltage Lockout	Rising Edge, 1% Hysteresis		1.8	2.4	V
V_{UVLO_HYS}	Under-voltage Lockout Hysteresis			10		mV
$R_{DS(ON)}$	On Resistance	$V_{IN} = 5.0V$, $T_A = 25^{\circ}C$		130	180	m Ω
		$V_{IN} = 3.0V$, $T_A = 25^{\circ}C$		150	230	
T_{CRDS}	On-Resistance Temperature Coefficient			2800		ppm/ $^{\circ}C$
I_{LIM}	Current Limit	$R_{SET} = 6.04k\Omega$, $V_{OUT} = V_{IN} - 0.5V$	0.71	0.75	0.79	A
$I_{LIM(MIN)}$	Minimum Current Limit			300		mA
$V_{ON(L)}$	ON/\overline{ON} Input Low Voltage	$V_{IN} = 2.4V$ to $5.5V$			0.5	V
$V_{ON(H)}$	ON/\overline{ON} Input High Voltage	$V_{IN} = 2.4V$ to $5.5V$	1.4			
$I_{ON(SINK)}$	ON/\overline{ON} Input Leakage	$V_{ON} = 5.5V$		0.01		μA
T_{RESP}	Current Limit Response Time	$V_{IN} = 5V$		2		μs
T_{ON}	Turn-On Time	$V_{IN} = 5V$, $R_O = 10\Omega$		5		
T_{OFF}	Turn-Off Time	$V_{IN} = 5V$, $R_O = 10\Omega$		10		
T_{BLANK}	Fault Flag Masking Time			4		ms
$V_{FLT(LO)}$	Fault Flag Logic Low Output	$I_{FLT(SINK)} = 1mA$			0.4	V
$I_{FLT(SINK)}$	Fault Flag Logic High Leakage Current			0.03	1	μA
T_{SD}	Over-Temperature Shutdown Threshold	$V_{IN} = 5V$		140		$^{\circ}C$
T_{SD_HYS}	Over-Temperature Shutdown Hysteresis			15		

Ultra High Precision Adjustable Current Limited Load Switch with Fault Flag

Quiescent Current vs Temperature

$V_{IN} = 5.0V$

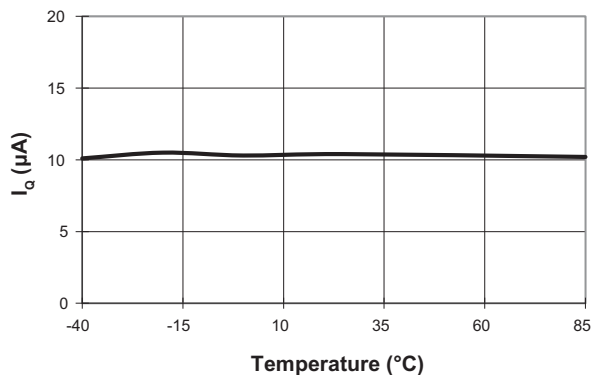

Current Limit vs Output Voltage

$V_{IN} = 5.0V, T_A = 25^\circ C, R_{SET} = 6.04k\Omega$

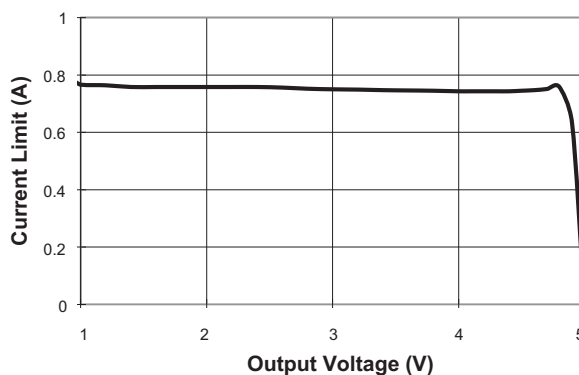

Quiescent Current vs Input Voltage

$T_A = 25^\circ C$

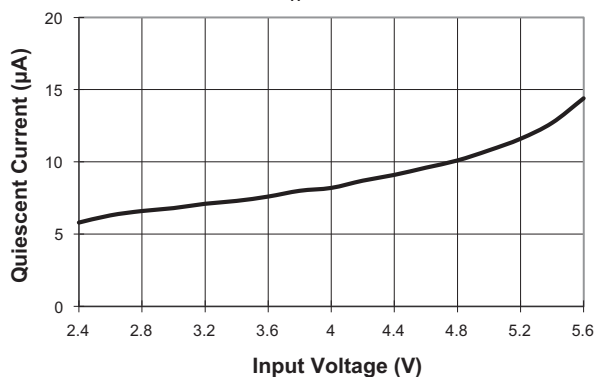

Off-Switch Current vs Temperature

$V_{IN} = 5.5V$

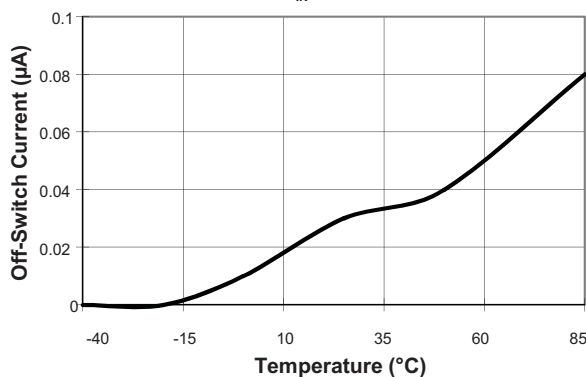

$R_{DS(ON)}$ vs Temperature

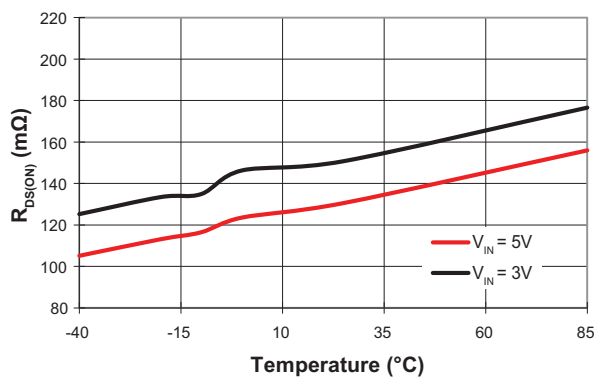

R_{SET} vs I_{LIM}

$T_A = 25^\circ C$

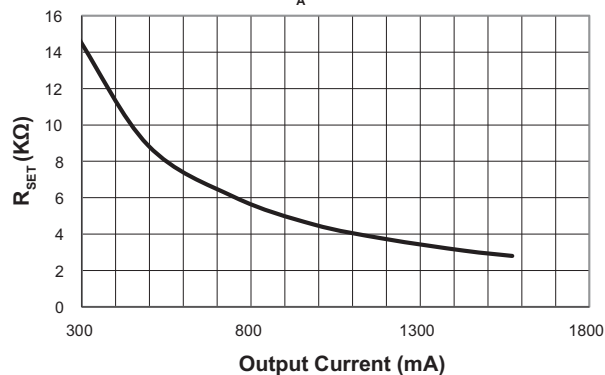

AAT4616

Ultra High Precision Adjustable Current Limited Load Switch with Fault Flag

$\overline{\text{ON}}(\overline{\text{ON}})$ Threshold vs Input Voltage

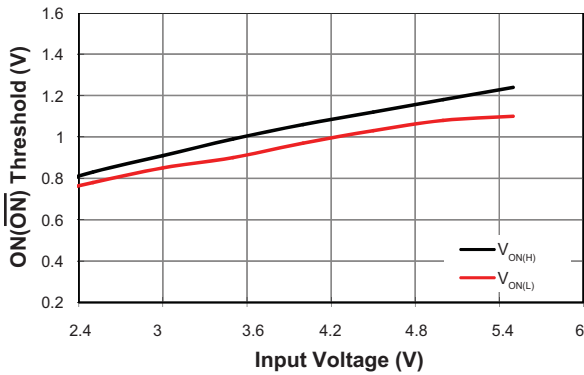

AAT4616IPS-1 and AAT4616IGV-1 Turn-On
($R_L = 10\Omega$; $C_L = 0.47\mu\text{F}$)

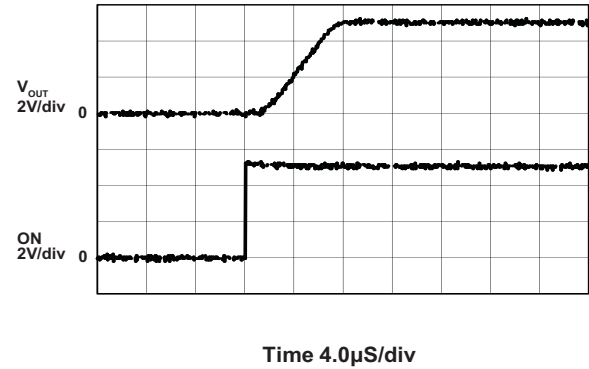

AAT4616IPS-1 and AAT4616IGV-1 Turn-Off
($R_L = 10\Omega$; $C_L = 0.47\mu\text{F}$)

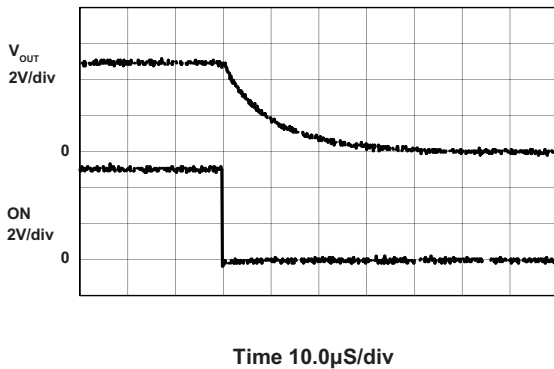

Short Circuit Through 0.3Ω
 $V_{\text{IN}} = 5\text{V}$

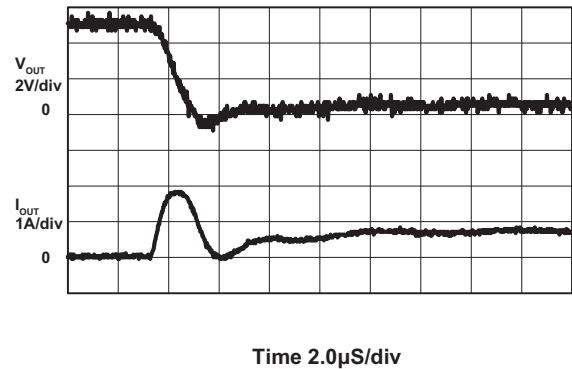

Output Short Response
 $V_{\text{IN}} = 5\text{V}$

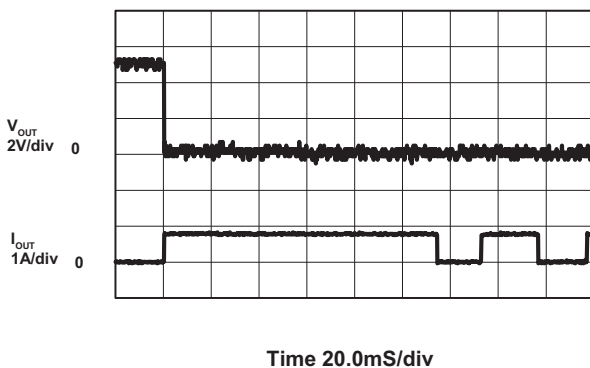

Fault Masking Time
 $V_{\text{IN}} = 5\text{V}$

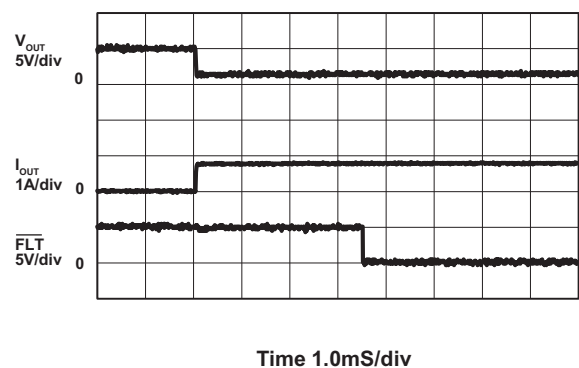

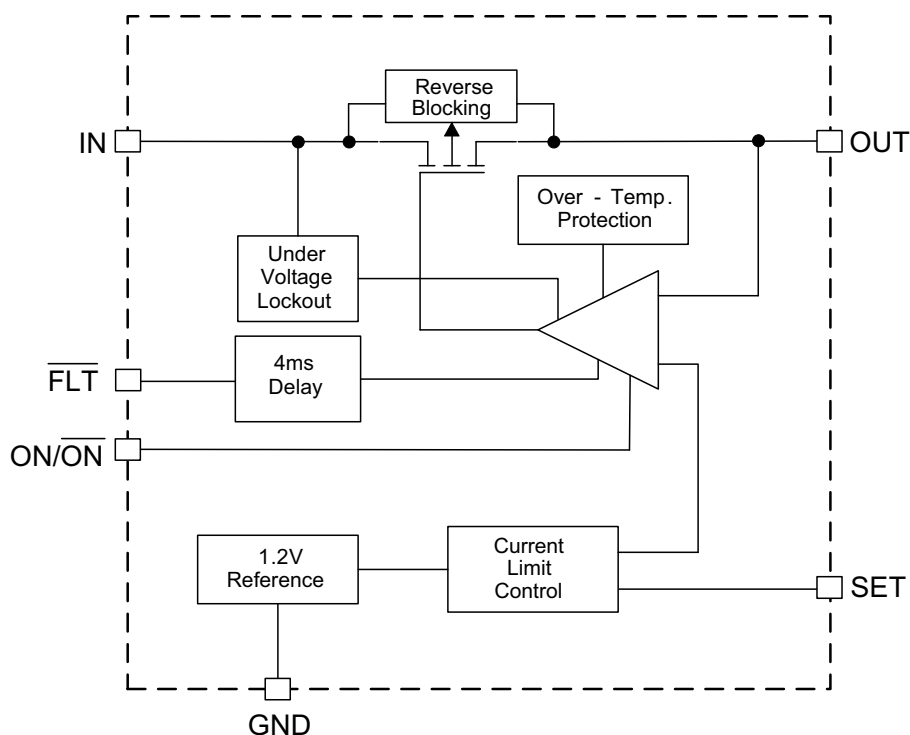
Ultra High Precision Adjustable Current Limited Load Switch with Fault Flag**Functional Block Diagram****Functional Description**

The AAT4616 is a single channel current limiting load switch that is intended to protect against short circuit and over-current events by current limiting to a preset level. This device also provides a reverse current blocking feature, ON/OFF enable control and a fault flag to notify a system controller of an over-current, short circuit or over-temperature event. Highly accurate current limit ensures excellent performance over part, process and temperature variations.

In the event of a load current exceeding a user programmed current limit level (I_{LIM}), a high speed current limit loop limits the current in a microsecond and will reset to low impedance once the short-circuit condition is removed. The AAT4616 is internally protected from thermal damage by an over-temperature detection circuit. If the die temperature reaches the internal thermal limit, the power device is switched off until the die temperature cools to a level below the thermal limit threshold. This device may operate in a thermal cycling state indefinitely or until the over-current condition is removed.

The AAT4616 operates with input voltages ranging from 2.4V to 5.5V which, along with its extremely low operating current, makes it ideal for battery-powered applications. In cases where the input voltage drops below 2.4V, the AAT4616 MOSFET is protected from entering the saturated region of operation by being automatically shutting down via an under-voltage lockout circuit.

Current limit or over temperature conditions are reported by the open drain FAULT output. A 4ms masking interval prevents false reporting during the charging of a capacitive load, which typically occurs during device turn-on, but may also occur during a port hot plug-in event. The AAT4616 is ideally suited for protection of peripheral ports such as USB, RS232, and parallel ports.

Reverse Current Blocking

The reverse current blocking feature prevents current to flow from OUT to IN when the device is disabled. When the device is enabled, the electrical characteristics between IN and OUT is still similar to an ideal switch, current can flow in either direction.

Ultra High Precision Adjustable Current Limited Load Switch with Fault Flag

Application Information

Setting Current Limit

AAT4616 current limit can be set by an external resistor (R_{SET}) connected from the SET pin to GND. R_{SET} can be calculated by the following equation:

$$R_{SET} = \frac{750\text{mA}}{I_{LIM}} \cdot 6\text{k}\Omega$$

where I_{LIM} is in mA and R_{SET} in $\text{k}\Omega$.

Table 1 summarizes resistor values for current limit settings. Use 1% tolerance metal film resistors for programming the desired current limit setting. Figure 1 shows the output current vs output voltage with R_{SET} equal to 6.04k Ω .

R_{SET} (k Ω)	Current Limit (mA)
15	300
8.87	500
6.04	750
4.53	1000
3.74	1200
3.09	1400
2.8	1600

Table 1: Recommended 1% Tolerance Metal Film Resistors R_{SET} for Current Limit.

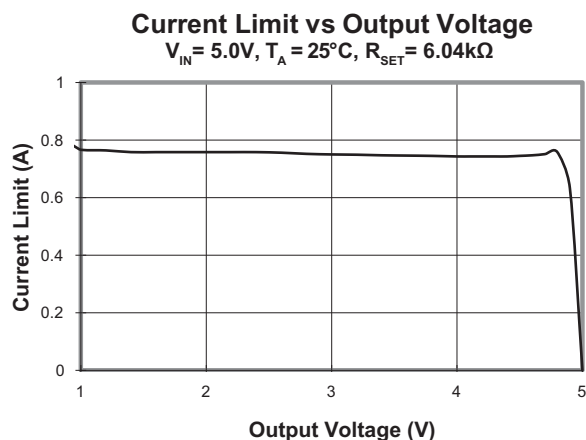

Figure 1: Current Limit vs Output Voltage with 6.04k Ω R_{SET} .

Input Capacitor

The input capacitor C_{IN} protects the power supply from current transients generated by the load attached to the AAT4616. When a short circuit is suddenly applied to the output of the AAT4616, a large current, limited only by the $R_{DS(ON)}$ of the MOSFET, will flow for less than 1 μs before the current limit circuitry activates. In this event, a moderately sized C_{IN} will dramatically reduce the voltage transient seen by the power supply and by other circuitry upstream from the AAT4616. The extremely fast short-circuit response time of the AAT4616 reduces the size requirement for C_{IN} . C_{IN} should be located as close to the device VIN pin as practically possible. Ceramic, tantalum, or aluminum electrolytic capacitors are appropriate for C_{IN} . There is no specific capacitor ESR requirement for C_{IN} . For higher current operation, ceramic capacitors are recommended for C_{IN} due to their inherent capability over tantalum capacitors to withstand input current surges from low impedance sources such as batteries in portable devices.

Output Capacitor

In order to insure stability while current limit is active, a low capacitance (approximately 0.47 μF) is required. No matter how large the output capacitor, output current is limited to the value set by the AAT4616 current limiting circuitry, so very large output capacitors can be used.

For example, USB ports are specified to have at least 120 μF of capacitance downstream from their controlling power switch. The current limiting circuit will allow an output capacitance of 1000 μF or more without disturbing the upstream power supply.

ON/ $\overline{\text{ON}}$ (Enable Input)

In many systems, power planes are controlled by integrated circuits which run at lower voltages than the power planes themselves. The enable input (ON/ $\overline{\text{ON}}$) of the AAT4616 has low and high threshold voltages that accommodate this condition. The threshold voltages are compatible with 5V TTL and 2.5V to 5V CMOS systems.

Both active high and active low options are available for all packages.

Ultra High Precision Adjustable Current Limited Load Switch with Fault Flag

Connecting to Capacitive Load

When switching the AAT4616 onto a capacitive load, the AAT4616 will charge the output capacitive load at a rate no greater than the current limit setting.

FAULT Output

The FAULT Flag (\overline{FLT}) is provided to alert the system if an AAT4616 load is not receiving sufficient voltage to operate properly. If current limit or over-temperature circuits in any combination are active for more than approximately 4ms, the FAULT Flag is pulled to ground through an approximately 100 Ω resistor. The filtering of voltage or current transients of less than 4ms prevents capacitive loads connected to the AAT4616 output from activating the FAULT Flag when they are initially attached. Pull-up resistances of 10k Ω to 100k Ω are recommended. Since \overline{FLT} is an open drain terminal; it may be pulled up to any unrelated voltage less than the maximum operating voltage of 5.5V, allowing for level shifting between circuits.

Thermal Considerations

Since the AAT4616 has internal current limit and over-temperature protection, junction temperature is rarely a concern. However, if the application requires large currents in a hot environment, it is possible that temperature, rather than current limit, will be the dominant regulating condition. In these applications, the maximum current available without risk of an over-temperature condition must be calculated. The maximum internal temperature while current limit is not active can be calculated using:

$$T_{J(MAX)} = I_{MAX(OUT)-SW(MAX)}^2 \cdot R_{DS(ON)(MAX)} \cdot R_{\theta JA} + T_{A(MAX)}$$

where

I_{MAX} is the maximum current required by the load,

$R_{DS(ON)(MAX)}$ is the maximum rated $R_{DS(ON)}$ of the AAT4616 at high temperature

$R_{\theta JA}$ is the thermal resistance between the AAT4616 die and the board onto which it is mounted

$T_{A(MAX)}$ is the maximum temperature that the PCB under the AAT4616 would be if the AAT4616 were not dissipating power.

Rearranging the equation to solve for I_{MAX} , we get:

$$I_{MAX} = \sqrt{\frac{T_{SD(MIN)} - T_{A(MAX)}}{R_{DS(ON)(MAX)} \cdot R_{\theta JA}}}$$

Note that $T_{J(MAX)}$ has been replaced by $T_{SD(MIN)}$, the minimum temperature required to activate the AAT4616's over-temperature protection. With the typical specification of 140°C, 125°C is a safe minimum value to use.

For example, if an application is specified to operate in 50°C environments, the PCB operates at temperatures as high as 85°C. The application is sealed and its PCB is small, causing $R_{\theta JA}$ to be approximately 74°C/W (TDFN22-8 package) and 220°C/W (SOT23-5 package). Using the equation above, we get:

$$I_{MAX} = \sqrt{\frac{125 - 85}{0.23 \cdot 74}} \text{ for TDFN22-8}$$

or

$$I_{MAX} = \sqrt{\frac{125 - 85}{0.23 \cdot 220}} \text{ for SOT23}$$

AAT4616

Ultra High Precision Adjustable Current Limited Load Switch with Fault Flag

Evaluation Boards

AAT4616IPS Schematic

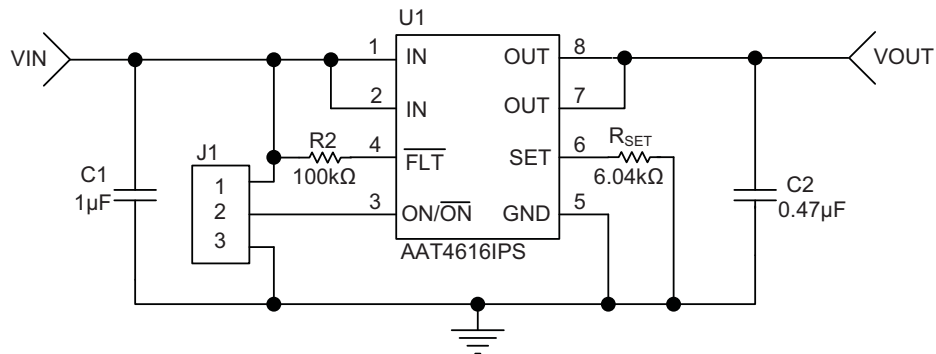
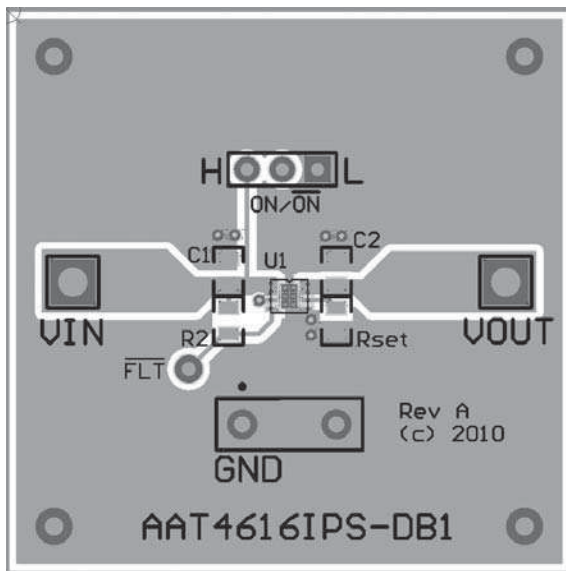
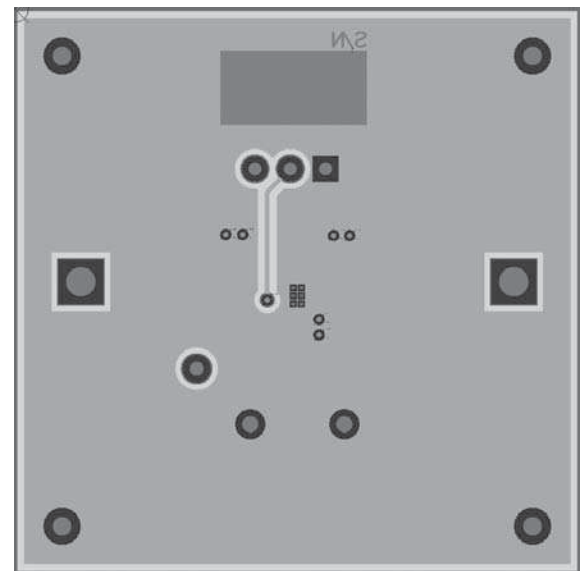

Figure 2: AAT4616IPS Evaluation Board Schematic

AAT4616IPS Board Layout



(a): Top Side



(b): Bottom Side

Figure 3: AAT4616IPS Evaluation Board Layout

AAT4616

Ultra High Precision Adjustable Current Limited Load Switch with Fault Flag

AAT4616IGV Schematic

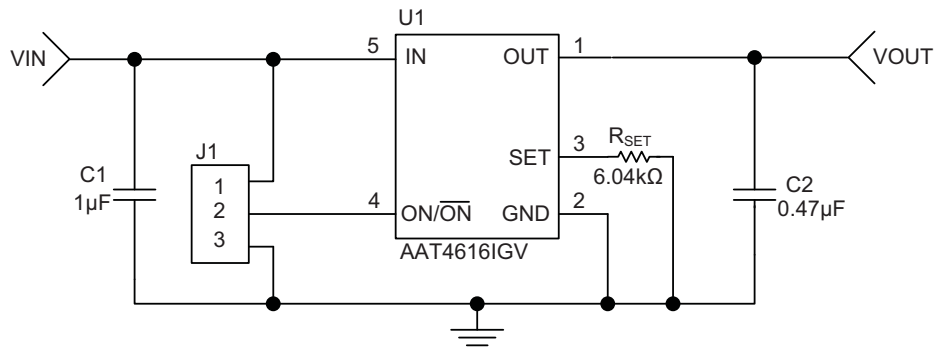
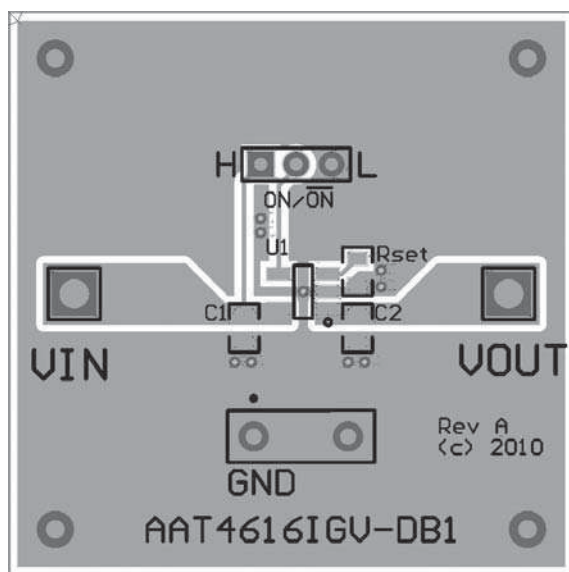
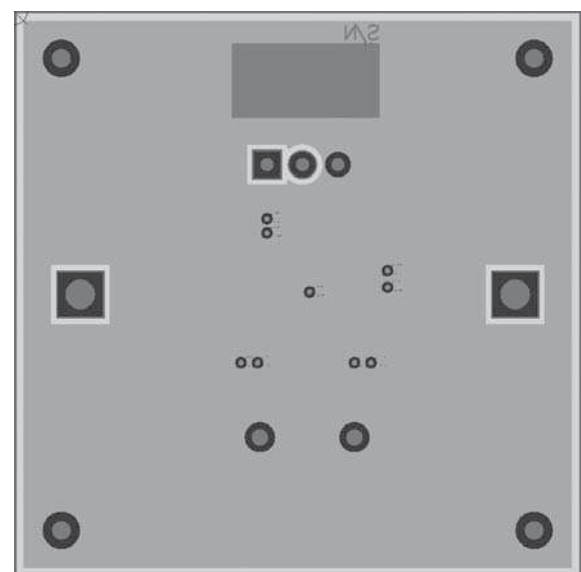

Figure 4: AAT4616IGV Evaluation Board Schematic

AAT4616IGV Board Layout



(a): Top Side



(b): Bottom Side

Figure 5: AAT4616 Evaluation Board Layout

Component	Part Number	Description	Manufacturer
U1	AAT4616	Current Limited Load Switch	Skyworks
C1	GRM188R71C105K	Cap Ceramic 1μF 0603 X7R 16V 10%	Murata
C2	GRM188R71C474K	Cap Ceramic 0.47μF 0603 X7R 16V 10%	
RSET	Chip Resistor	Res 6.04kΩ 1/16W 1% 0603 SMD	Vishay
R2	Chip Resistor	Res 100kΩ 1/16W 1% 0603 SMD	

Table 2: AAT4616 Evaluation Board Bill of Materials.

AAT4616

Ultra High Precision Adjustable Current Limited Load Switch with Fault Flag

Ordering Information

Enable Input	Package	Marking ¹	Part Number (Tape and Reel) ²
Active High	TDFN22-8	R8XYY	AAT4616IPS-1-T1
Active Low	TDFN22-8	U6VBF	AAT4616IPS-T1
Active High	SOT23-5	R7XYY	AAT4616IGV-1-T1
Active Low	SOT23-5	U5IBF	AAT4616IGV-T1



Skyworks Green™ products are compliant with all applicable legislation and are halogen-free. For additional information, refer to *Skyworks Definition of Green™*, document number SQ04-0074.

Package Information

TDFN22-8

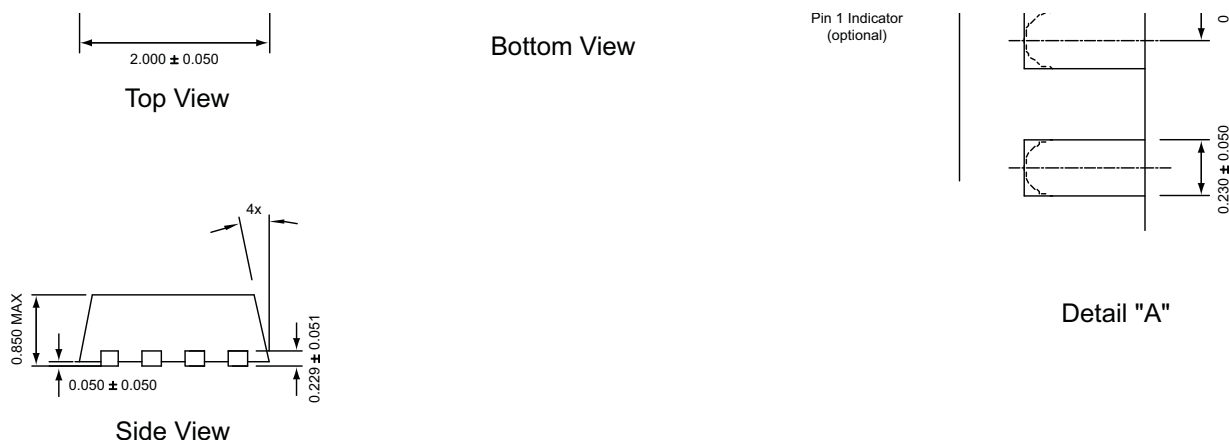

All dimensions in millimeters

1. XYY = assembly and date code.
2. Sample stock is generally held on all part numbers listed in **BOLD**.

Ultra High Precision Adjustable Current Limited Load Switch with Fault Flag

SOT23-5

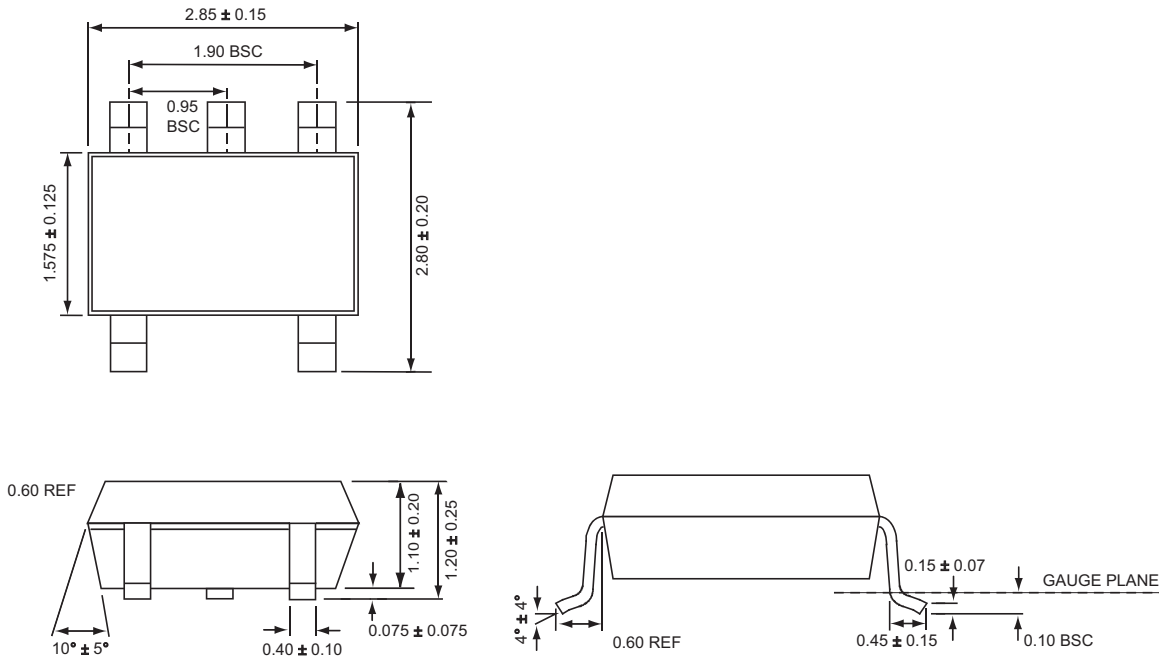

Copyright © 2012 Skyworks Solutions, Inc. All Rights Reserved.

Information in this document is provided in connection with Skyworks Solutions, Inc. ("Skyworks") products or services. These materials, including the information contained herein, are provided by Skyworks as a service to its customers and may be used for informational purposes only by the customer. Skyworks assumes no responsibility for errors or omissions in these materials or the information contained herein. Skyworks may change its documentation, products, services, specifications or product descriptions at any time, without notice. Skyworks makes no commitment to update the materials or information and shall have no responsibility whatsoever for conflicts, incompatibilities, or other difficulties arising from any future changes.

No license, whether express, implied, by estoppel or otherwise, is granted to any intellectual property rights by this document. Skyworks assumes no liability for any materials, products or information provided hereunder, including the sale, distribution, reproduction or use of Skyworks products, information or materials, except as may be provided in Skyworks Terms and Conditions of Sale.

THE MATERIALS, PRODUCTS AND INFORMATION ARE PROVIDED "AS IS" WITHOUT WARRANTY OF ANY KIND, WHETHER EXPRESS, IMPLIED, STATUTORY, OR OTHERWISE, INCLUDING FITNESS FOR A PARTICULAR PURPOSE OR USE, MERCHANTABILITY, PERFORMANCE, QUALITY OR NON-INFRINGEMENT OF ANY INTELLECTUAL PROPERTY RIGHT; ALL SUCH WARRANTIES ARE HEREBY EXPRESSLY DISCLAIMED. SKYWORKS DOES NOT WARRANT THE ACCURACY OR COMPLETENESS OF THE INFORMATION, TEXT, GRAPHICS OR OTHER ITEMS CONTAINED WITHIN THESE MATERIALS. SKYWORKS SHALL NOT BE LIABLE FOR ANY DAMAGES, INCLUDING BUT NOT LIMITED TO ANY SPECIAL, INDIRECT, INCIDENTAL, STATUTORY, OR CONSEQUENTIAL DAMAGES, INCLUDING WITHOUT LIMITATION, LOST REVENUES OR LOST PROFITS THAT MAY RESULT FROM THE USE OF THE MATERIALS OR INFORMATION, WHETHER OR NOT THE RECIPIENT OF MATERIALS HAS BEEN ADVISED OF THE POSSIBILITY OF SUCH DAMAGE.

Skyworks products are not intended for use in medical, lifesaving or life-sustaining applications, or other equipment in which the failure of the Skyworks products could lead to personal injury, death, physical or environmental damage. Skyworks customers using or selling Skyworks products for use in such applications do so at their own risk and agree to fully indemnify Skyworks for any damages resulting from such improper use or sale.

Customers are responsible for their products and applications using Skyworks products, which may deviate from published specifications as a result of design defects, errors, or operation of products outside of published parameters or design specifications. Customers should include design and operating safeguards to minimize these and other risks. Skyworks assumes no liability for applications assistance, customer product design, or damage to any equipment resulting from the use of Skyworks products outside of stated published specifications or parameters.

Skyworks, the Skyworks symbol, and "Breakthrough Simplicity" are trademarks or registered trademarks of Skyworks Solutions, Inc., in the United States and other countries. Third-party brands and names are for identification purposes only, and are the property of their respective owners. Additional information, including relevant terms and conditions, posted at www.skyworksinc.com, are incorporated by reference.