

Adjustable Current Limited Load Switch with Fault Flag

General Description

The AAT4614 SmartSwitch is a current limited P-channel MOSFET power switch designed for high side load switching applications. This switch operates with inputs ranging from 2.4V to 5.5V, making it ideal for both 3V and 5V systems. An integrated current-limiting circuit protects the input supply against large currents which may cause the supply to fall out of regulation. Reverse current blocking is provided to protect the load switch from reverse current potentials while the device is shutdown.

The AAT4614 is also protected from thermal overload which is limited by power dissipation and junction temperatures. Current limit threshold is programmed with a resistor from SET to ground and may be adjusted for levels up to 1.4A. The ultra-fast current limit response to a sudden short circuit is a mere 1 μ s which reduces the requirements of local supply bypassing. An open drain FAULT flag signals an over-current or over-temperature condition after a 4ms blanking time to prevent false reporting. Quiescent current is a low 10 μ A and the supply current decreases to less than 1 μ A in shutdown mode.

The AAT4614 is offered in the small Pb-free, 8-pin SC70JW, SOT23-6 and SOT23-5 packages, and is specified for operation over the -40 $^{\circ}$ C to +85 $^{\circ}$ C ambient temperature range.

Features

- Input Voltage Range: 2.4V to 5.5V
- Programmable Over-Current Threshold
- Fast Transient Response:
 - 1 μ s Response to Short Circuit
- Low Quiescent Current
 - 10 μ A Typical while Enabled
 - 1 μ A Max with Switch Off ($T_A = 25^{\circ}$ C)
- 130m Ω Typical $R_{DS(ON)}$
- Only 2.4V Needed for ON/OFF Control
- Under-Voltage Lockout
- Reverse Blocking During Disable
- 4ms Fault Blanking
- Fault Flag Open Drain Output (Not Available for SOT23-5 Package)
- Active Hi/Lo Enable Options
- Over-Temperature Protection
- 4kV ESD Rating
- 6-Pin SOT23, 5-Pin SOT23, or 8-Pin SC70JW Package
- Temperature Range: -40 $^{\circ}$ C to +85 $^{\circ}$ C

Applications

- Hot Swap Supplies
- Notebook Computers
- Portable Products
- Proprietary Peripheral Ports
- USB Ports

Typical Application

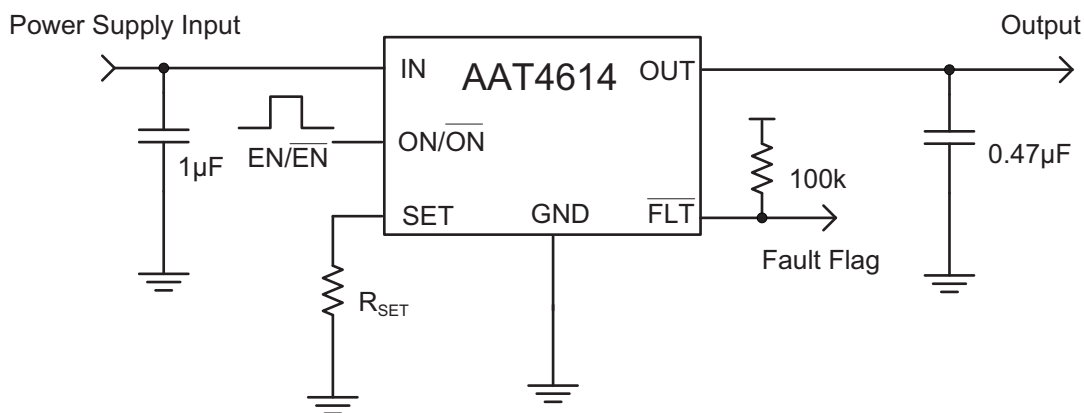

AAT4614

Adjustable Current Limited Load Switch with Fault Flag

Pin Description

Pin #			Symbol	Description
SOT23-6	SOT23-5	SC70JW-8		
1	1	5	OUT	Current limiting load switch output (high side P-channel MOSFET Drain). Connect a 0.47 μ F capacitor from OUT to GND for best load transient response.
2	2	6,7,8	GND	IC ground connection
3	n/a	1	FL \bar{T}	Current limit fault flag pin, open-drain output, active low signal. Pull up with a 10k Ω to 100k Ω resistor.
4	4	2	ON/ $\bar{O}N$	Load switch enable input. Active high and active low options are available.
5	3	3	SET	Current limit set pin. Connect a resistor between this pin and ground to program the desired current limit set point.
6	5	4	IN	Load switch power supply input pin (high side P-channel MOSFET source). Bypass with a 1 μ F capacitor from IN to GND.

Pin Configuration

**SOT23-6
(Top View)**

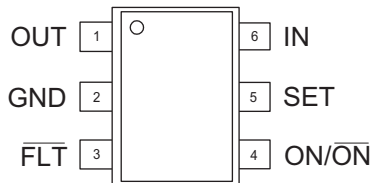

**SOT23-5
(Top View)**

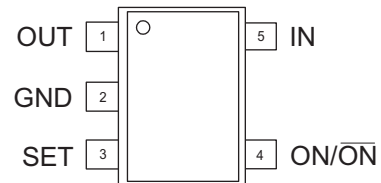

**SC70JW-8
(Top View)**

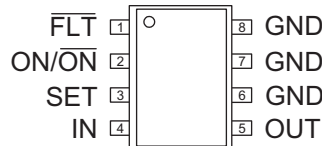

Adjustable Current Limited Load Switch with Fault Flag**Absolute Maximum Ratings¹**

Symbol	Description	Value	Units
V_{IN}	IN to GND	-0.3 to 6	V
V_{ON}, V_{FLT}	ON/ \overline{ON} , \overline{FLT} to GND	-0.3 to $V_{IN} + 0.3$	V
V_{OUT}, V_{SET}	OUT, SET to GND	-0.3 to $V_{IN} + 0.3$	V
I_{MAX}	Maximum DC Output Current ²	2000	mA
V_{ESD}	ESD Rating, HBM	4000	V
T_J	Maximum Junction Operating temperature	-40 to +150	°C
T_{LEAD}	Maximum Soldering Temperature (at leads, 10 sec)	300	°C

Thermal Information

Symbol	Package	Description	Value	Units
P_D	SOT23-6(-5)	Maximum Power Dissipation ^{2,3}	625	mW
	SC70JW8		667	mW
θ_{JA}	SOT23-6(-5)	Maximum Thermal Resistance ³	150	°C/W
	SC70JW8		160	°C/W

1. Stresses above those listed in Absolute Maximum Ratings may cause permanent damage to the device. Functional operation at conditions other than the operating conditions specified is not implied. Only one Absolute Maximum Rating should be applied at any one time.

2. Mounted on FR4 circuit board.

3. Derate 6.25mW/°C above 40°C ambient temperature

Adjustable Current Limited Load Switch with Fault Flag

Electrical Characteristics

$V_{IN} = 5V$; $T_A = -40^{\circ}C$ to $85^{\circ}C$ unless otherwise noted. Typical values are at $T_A = 25^{\circ}C$.

Symbol	Description	Conditions	Min	Typ	Max	Units
V_{IN}	Input Voltage Range		2.4		5.5	V
I_Q	Operation Quiescent Current	$V_{IN} = 5V$, ON/ \overline{ON} = Active, $I_{OUT} = 0$		10	25	μA
$I_{Q(OFF)}$	Off Supply Current	ON/ \overline{ON} = Inactive, $V_{IN} = 5.5V$		0.01	1	
$I_{SD(OFF)}$	Off Switch Current	ON/ \overline{ON} = Inactive, $V_{IN} = 5.5V$, $T_A = 25^{\circ}C$		0.01	1	
V_{UVLO}	Under-Voltage Lockout	Rising edge		1.8	2.4	V
V_{UVLO_HYS}	Under-Voltage Lockout Hysteresis			0.1		
$R_{DS(ON)}$	On-Resistance	$V_{IN} = 5.0V$, $T_A = 25^{\circ}C$		160	210	$m\Omega$
		$V_{IN} = 3.0V$, $T_A = 25^{\circ}C$		180	240	
TC_{RDS}	On-Resistance Temperature Coefficient			2800		ppm/ $^{\circ}C$
I_{LIM}	Current Limit	$R_{SET} = 6.8k\Omega$; $V_{OUT} = V_{IN} - 0.5V$	0.75	1	1.25	A
$V_{ON(L)}$	ON/ \overline{ON} Input Low Voltage	$V_{IN} = 2.7V$ to $5.5V$			0.6	V
$V_{ON(H)}$	ON/ \overline{ON} Input High Voltage	$V_{IN} = 2.7V$ to $<4.2V$	2.0			
		$V_{IN} \geq 4.2V$ to $5.5V$	2.4			
$I_{ON(SINK)}$	Input Leakage Current	$V_{ON} = 5.5V$		0.01	1	μA
T_{RESP}	Current Limit Response Time	$V_{IN} = 5V$		1		μs
T_{ON}	Turn On Time	$V_{IN} = 5V$; $R_O = 10\Omega$		12	200	
T_{OFF}	Turn Off Time	$V_{IN} = 5V$; $R_O = 10\Omega$		55	100	
T_{SD}	Over-Temperature Shutdown Threshold	$V_{IN} = 5V$	T_J Increasing	125		$^{\circ}C$
			T_J Decreasing	115		
T_{BLANK}	Fault Flag Blanking Time			4		ms
$V_{FLT(LO)}$	Fault Flag Logic Low Output	$I_{FLT(SINK)} = 1mA$			0.4	V
$I_{FLT(SINK)}$	Fault Flag Logic High Leakage Current			0.5	1	μA

Adjustable Current Limited Load Switch with Fault Flag

Typical Characteristics

Unless otherwise noted, $V_{IN} = 5V$, $T_A = 25^\circ C$, $R_{SET} = 6.8K\Omega$.

Quiescent Current vs. Temperature

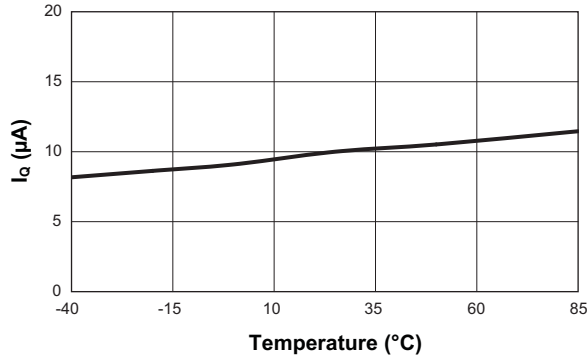

Output Current vs. Output Voltage
($R_{SET} = 6.8K\Omega$)

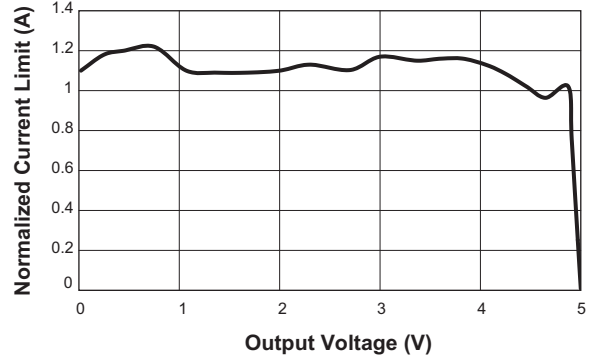

Quiescent Current vs. Input Voltage

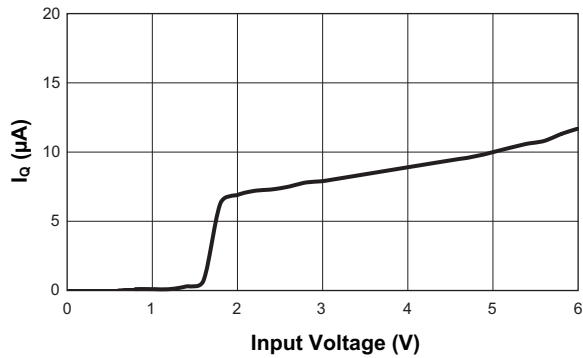

Off-Switch Current vs. Temperature

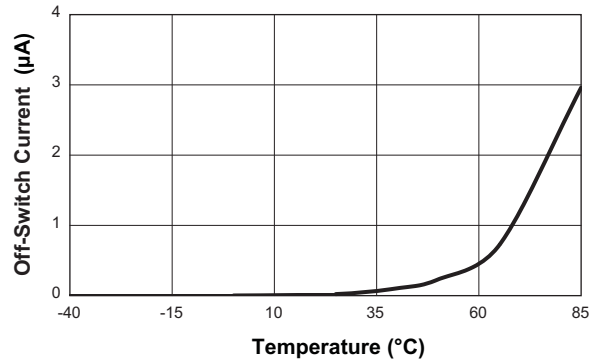

$R_{DS(ON)}$ vs. Temperature

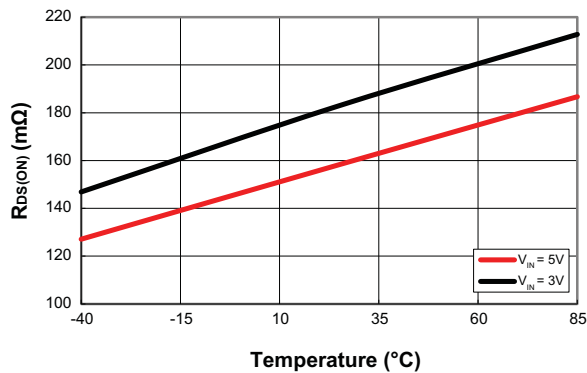

R_{SET} vs. I_{LIM}

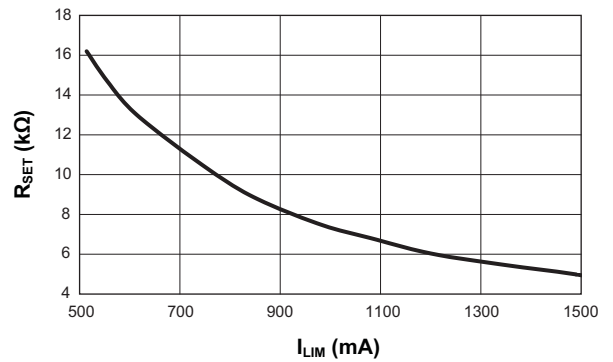

Adjustable Current Limited Load Switch with Fault Flag

Typical Characteristics

Unless otherwise noted, $V_{IN} = 5V$, $T_A = 25^\circ C$, $R_{SET} = 6.8K\Omega$.

ON(\overline{ON}) Threshold vs. Input Voltage

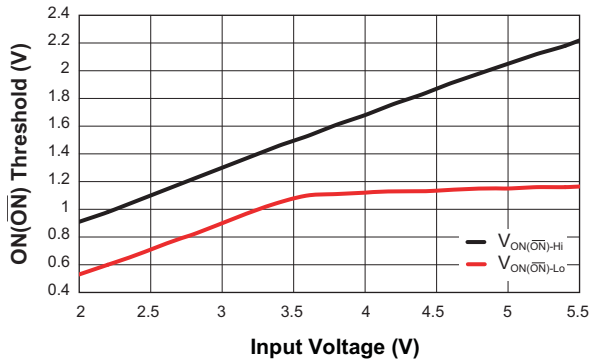

Turn-On
($R_L = 20\Omega$; $C_L = 0.47\mu F$)

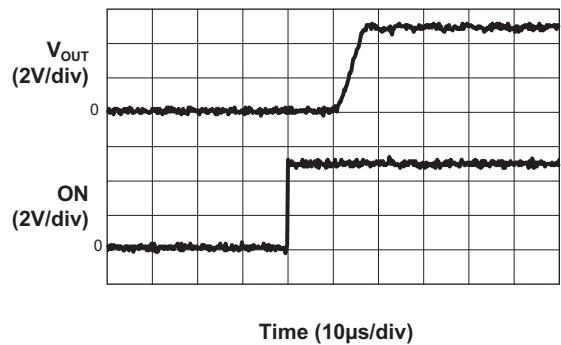

Turn-Off
($V_{IN} = 5.0V$; $R_L = 20\Omega$; $C_L = 0\mu F$)

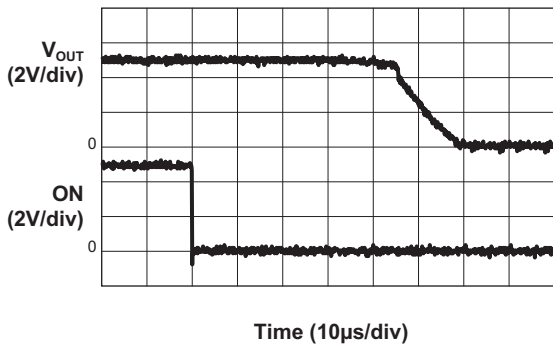

Short Circuit Through 0.3Ω Resistor

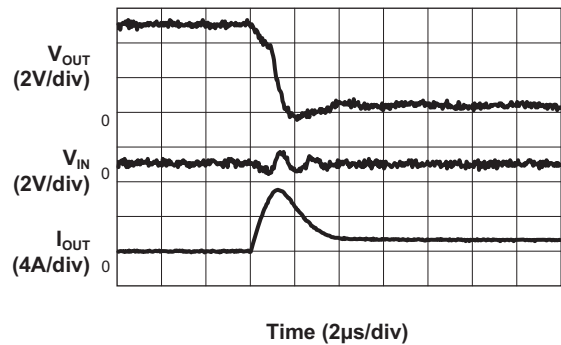

Thermal Shutdown Response
($R_L = 1\Omega$; $C_L = 0.47\mu F$)

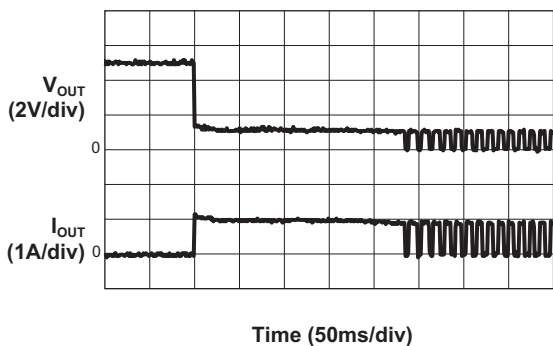

Fault Delay from Short Circuit

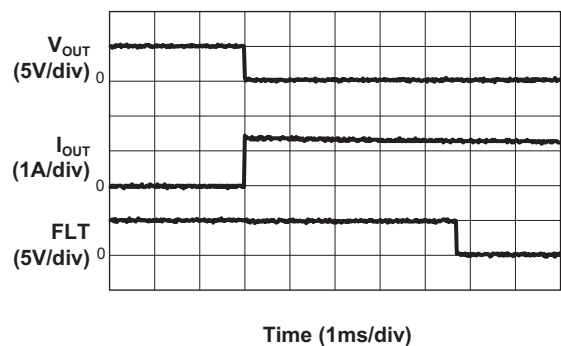

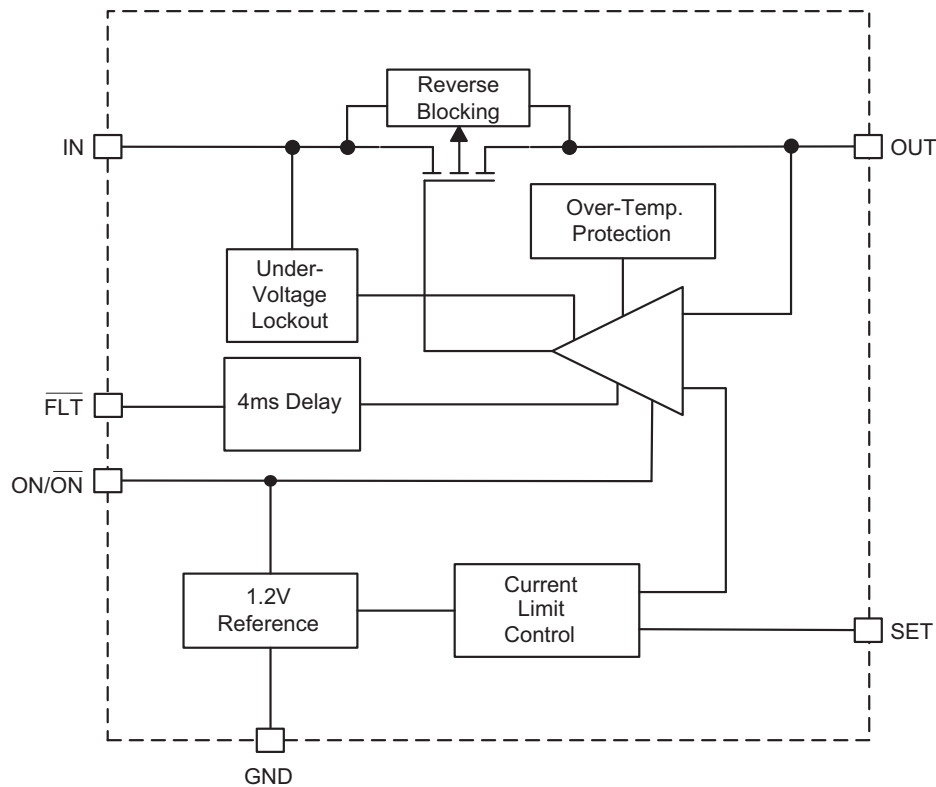
Adjustable Current Limited Load Switch with Fault Flag**Functional Block Diagram****Functional Description**

The AAT4614 is a single channel current limiting load switch that is intended to protect against short circuit and over current events by current limiting to a preset level. This device also provides a reverse current blocking feature, on / off enable control, and a fault flag to notify a system controller of an over current, short circuit or over temperature event.

In the event of a load current exceeding a user programmed current limit level (I_{LIM}), a high speed current limit loop limits the current in a microsecond and will reset to low impedance once the short-circuit condition is removed. The AAT4614 is internally protected from thermal damage by an over-temperature detection circuit. If the die temperature reaches the internal thermal limit, the power device is switched off until the die temperature cools to a level below the thermal limit threshold. This device may operate in a thermal cycling state indefinitely or until the over-current condition is removed.

The AAT4614 operates with input voltages ranging from 2.4V to 5.5V which, along with its extremely low operating current, makes it ideal for battery-powered applications. In cases where the input voltage drops below 2.4V, the AAT4614 MOSFET is protected from entering the saturated region of operation by being automatically shutting down via an under-voltage lockout circuit.

Current limit or over temperature conditions are reported by the open drain FAULT output. A 4ms blanking interval prevents false reporting during the charging of a capacitive load, which typically occurs during device turn-on, but may also occur during a port hot plug-in event. The AAT4614 is ideally suited for protection of peripheral ports such as USB, RS232, and parallel ports.

Reverse Current Blocking

The AAT4614's reverse current blocking feature prevents current to flow from OUT to IN when the device is disabled. When the device is enabled, the electrical characteristics between IN and OUT is still similar to an ideal switch; current can flow in either direction.

Adjustable Current Limited Load Switch with Fault Flag

Application Information

Setting the Current Limit

In most applications, the variation in I_{LIM} must be taken into account when determining R_{SET} . The I_{LIM} variation is due to processing variations from part to part, as well as variations in the voltages at IN and OUT, plus the operating temperature. Together, these three factors add up to a $\pm 25\%$ tolerance (see I_{LIM} specification in "Electrical Characteristics" section). Figure 1 illustrates a cold device with a statistically higher current limit and a hot device with a statistically lower current limit, both with R_{SET} equal to $10.5k\Omega$. While the chart, "R_{SET} vs. I_{LIM}" indicates an I_{LIM} of 0.7A with an R_{SET} of $10.5k\Omega$, this figure shows that the actual current limit will be at least 0.525A and no greater than 0.875A.

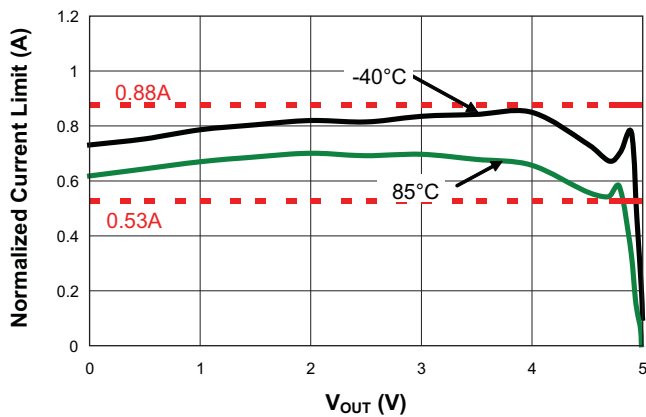

Figure 1: Current Limit at High and Low Temperature Using 10.5kΩ

To determine R_{SET} , start with the application required current limit as the minimum current limit value and multiply it by 1.33 to derive the typical current limit value. Next, refer to Table 1 to find the approximate R_{SET} value. For greater precision, use the small current limit range linear approximation to calculate R_{SET} value. For example, for 500mA current limit requirement, first calculate the typical current limit: $500 \cdot 1.33 = 665mA$. Then refer to Table 1; the nearest small current limit range is 600mA to 700mA with 100mA current limit interval and 0.45kV $R_{SET}I_{LIM}$ coefficient interval. Then adopt the method of linear approximation in small range to calculate the $R_{SET}I_{LIM}$ coefficient.

$$R_{SET} \cdot I_{LIM} = 7.8 - \frac{0.45 \cdot (665 - 600)}{100} = 7.51kV$$

So,

$$R_{SET} = \frac{7.51kV}{665mA} = 11.3k\Omega$$

R_{SET} (kΩ)	I_{LIM} Typ. (mA)	$R_{SET} \cdot I_{LIM}$ Coefficient (kV)
16.2	500	8.10
14.7	550	8.09
13.0	600	7.80
10.5	700	7.35
8.87	800	7.10
7.50	900	6.75
6.81	1000	6.81
6.04	1100	6.64
5.49	1200	6.59
4.99	1300	6.49
4.64	1400	6.50

Table 1: Current Limit Standard R_{SET} Values.

Input Capacitor

The input capacitor C_{IN} protects the power supply from current transients generated by the load attached to the AAT4614. When a short circuit is suddenly applied to the output of the AAT4614, a large current, limited only by the $R_{DS(ON)}$ of the MOSFET, will flow for less than $1\mu s$ before the current limit circuitry activates. (See the curve "Short Circuit Through 0.3Ω " in the "Typical Characteristics" section of this datasheet.) In this event, a moderately sized C_{IN} will dramatically reduce the voltage transient seen by the power supply and by other circuitry upstream from the AAT4614. The extremely fast short-circuit response time of the AAT4614 reduces the size requirement for C_{IN} .

C_{IN} should be located as close to the device VIN pin as practically possible. Ceramic, tantalum, or aluminum electrolytic capacitors are appropriate for C_{IN} . There is no specific capacitor ESR requirement for C_{IN} . However, for higher current operation, ceramic capacitors are recommended for C_{IN} due to their inherent capability over tantalum capacitors to withstand input current surges from low impedance sources such as batteries in portable devices.

Adjustable Current Limited Load Switch with Fault Flag**Output Capacitor**

In order to insure stability while current limit is active, a low capacitance (approximately 0.47 μ F) is required. No matter how large the output capacitor, output current is limited to the value set by the AAT4614 current limiting circuitry, so very large output capacitors can be used.

For example, USB ports are specified to have at least 120 μ F of capacitance downstream from their controlling power switch. The current limiting circuit will allow an output capacitance of 1000 μ F or more without disturbing the upstream power supply.

ON/ $\overline{\text{ON}}$ (Enable Input)

In many systems, power planes are controlled by integrated circuits which run at lower voltages than the power planes themselves. The enable input (ON) of the AAT4614 has low and high threshold voltages that accommodate this condition. The threshold voltages are compatible with 5V TTL and 2.5V to 5V CMOS systems. Both active high and active low options are available for all packages.

Connecting to Capacitive Load

When switching the AAT4614 onto a capacitive load, the AAT4614 will charge the output capacitive load at a rate no greater than the current limit setting.

FAULT Output

The FAULT Flag ($\overline{\text{FLT}}$) is provided to alert the system if an AAT4614 load is not receiving sufficient voltage to operate properly. If current limit or over-temperature circuits in any combination are active for more than approximately 4ms, the FAULT Flag is pulled to ground through an approximately 100 Ω resistor. The filtering of voltage or current transients of less than 4ms prevents capacitive loads connected to the AAT4614 output from activating the FAULT Flag when they are initially attached. Pull-up resistances of 1k Ω to 100k Ω are recommended. Since $\overline{\text{FLT}}$ is an open drain terminal, it may be pulled up to any unrelated voltage less than the maximum operating voltage of 5.5V, allowing for level shifting between circuits. The $\overline{\text{FLT}}$ Pin is not available for the SOT23-5 package.

Thermal Considerations

Since the AAT4614 has internal current limit and over-temperature protection, junction temperature is rarely a concern. However, if the application requires large currents in a hot environment, it is possible that temperature, rather than current limit, will be the dominant regulating condition. In these applications, the maximum current available without risk of an over-temperature condition must be calculated. The maximum internal temperature while current limit is not active can be calculated using Equation 1.

$$\text{Eq. 1: } T_{J(\text{MAX})} = I_{\text{MAX}}^2 \cdot R_{\text{DS(ON)(MAX)}} \cdot R_{\theta\text{JA}} + T_{A(\text{MAX})}$$

In Equation 1, I_{MAX} is the maximum current required by the load. $R_{\text{DS(ON)(MAX)}}$ is the maximum rated $R_{\text{DS(ON)}}$ of the AAT4614 at high temperature. $R_{\theta\text{JA}}$ is the thermal resistance between the AAT4614 die and the board onto which it is mounted. $T_{A(\text{MAX})}$ is the maximum temperature that the PCB under the AAT4614 would be if the AAT4614 were not dissipating power. Equation 1 can be rearranged to solve for I_{MAX} , as shown in Equation 2.

$$\text{Eq. 2: } I_{\text{MAX}} = \sqrt{\frac{T_{\text{SD(MIN)}} - T_{A(\text{MAX})}}{R_{\text{DS(ON)(MAX)}} \cdot R_{\theta\text{JA}}}}$$

$T_{\text{SD(MIN)}}$ is the minimum temperature required to activate the AAT4614's over-temperature protection. With the typical specification of 125 $^{\circ}$ C, 115 $^{\circ}$ C is a safe minimum value to use.

For example, if an application is specified to operate in 50 $^{\circ}$ C environments, the PCB operates at temperatures as high as 85 $^{\circ}$ C. The application is sealed and its PCB is small, causing $R_{\theta\text{JA}}$ to be approximately 150 $^{\circ}$ C/W. Using Equation 2,

$$\text{Eq. 3: } I_{\text{MAX}} = \sqrt{\frac{115 - 85}{0.23 \cdot 150}} = 0.93(\text{A})$$

Adjustable Current Limited Load Switch with Fault Flag

Evaluation Board PCB Layout

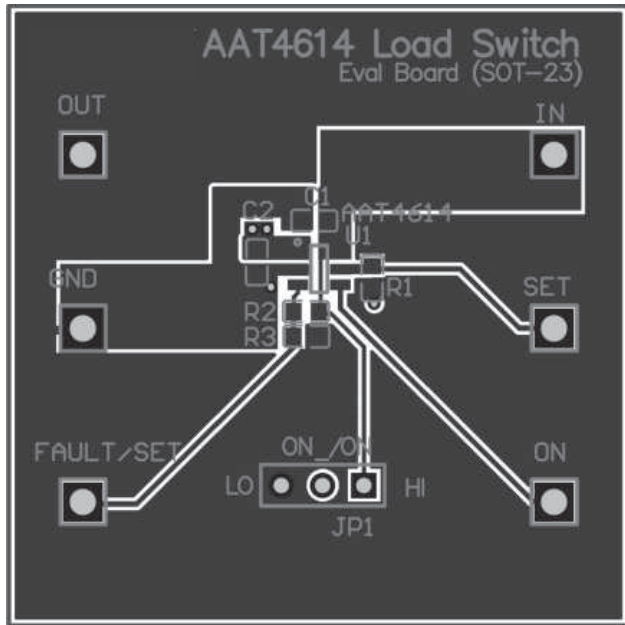

Figure 2: AAT4614 Evaluation Board Layout for SOT23-6 and SOT23-5 Package (Top View).

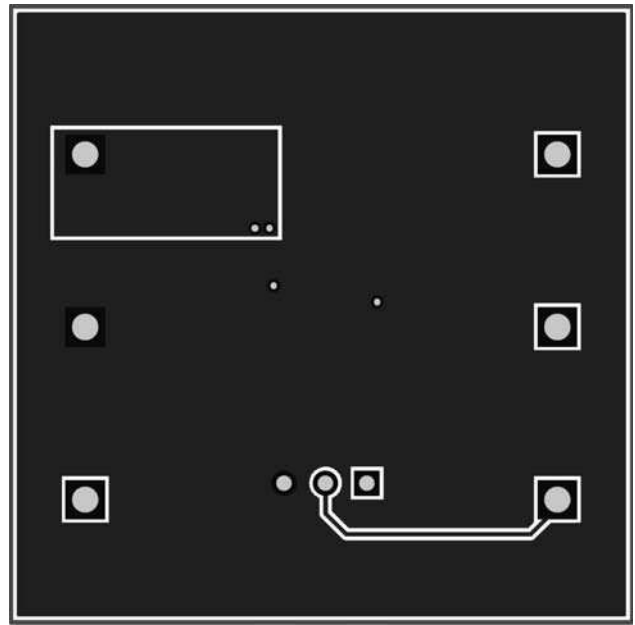

Figure 3: AAT4614 Evaluation Board Layout for SOT23-6 and SOT23-5 Package (Bottom View).

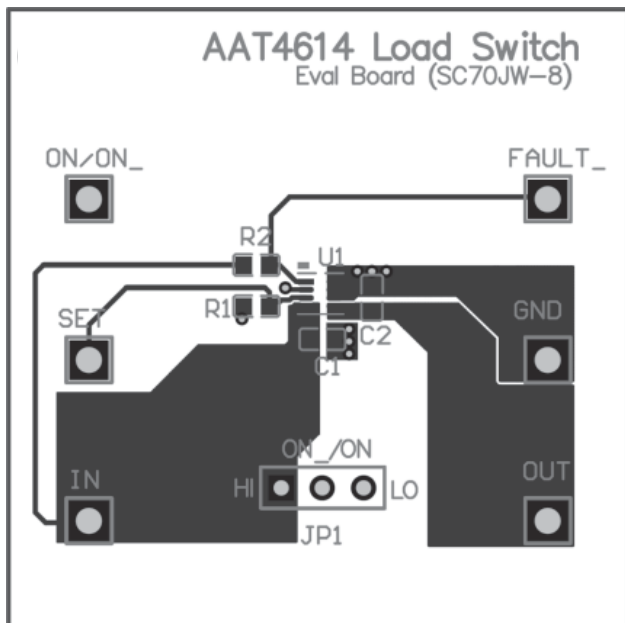

Figure 4: AAT4614 Evaluation Board Layout for SC70JW-8 Package (Top View).

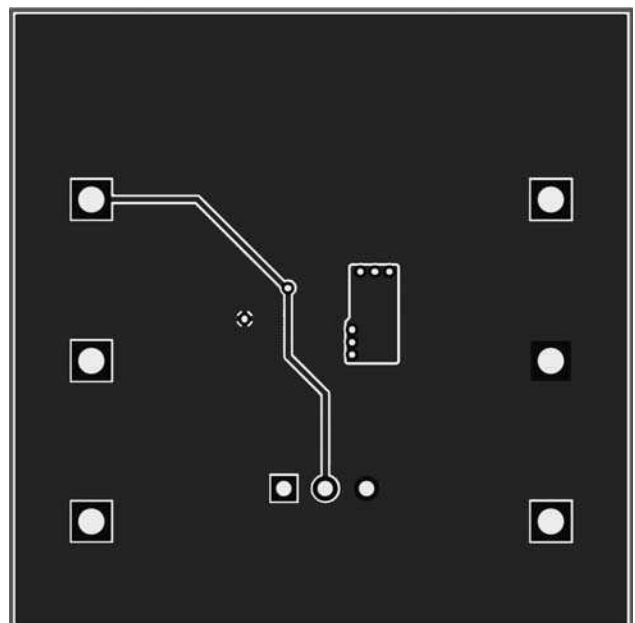

Figure 5: AAT4614 Evaluation Board Layout for SC70JW-8 Package (Bottom View).

AAT4614

Adjustable Current Limited Load Switch with Fault Flag

Evaluation Board Schematic

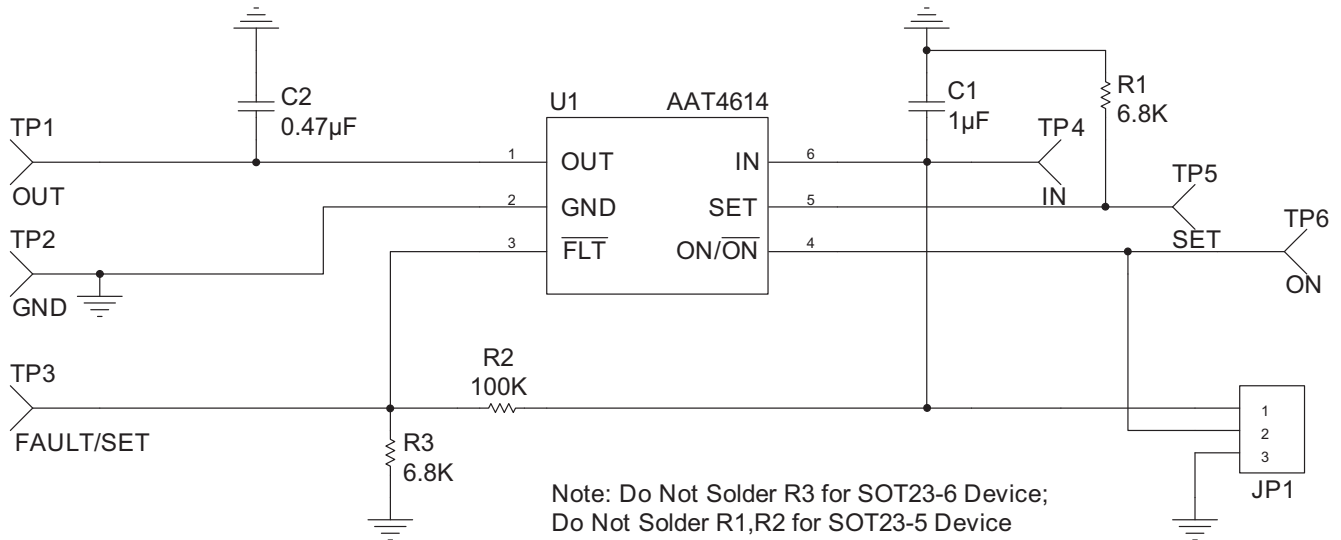

Figure 6: AAT4614 Evaluation Board Schematic for SOT23-6 and SOT23-5 Package.

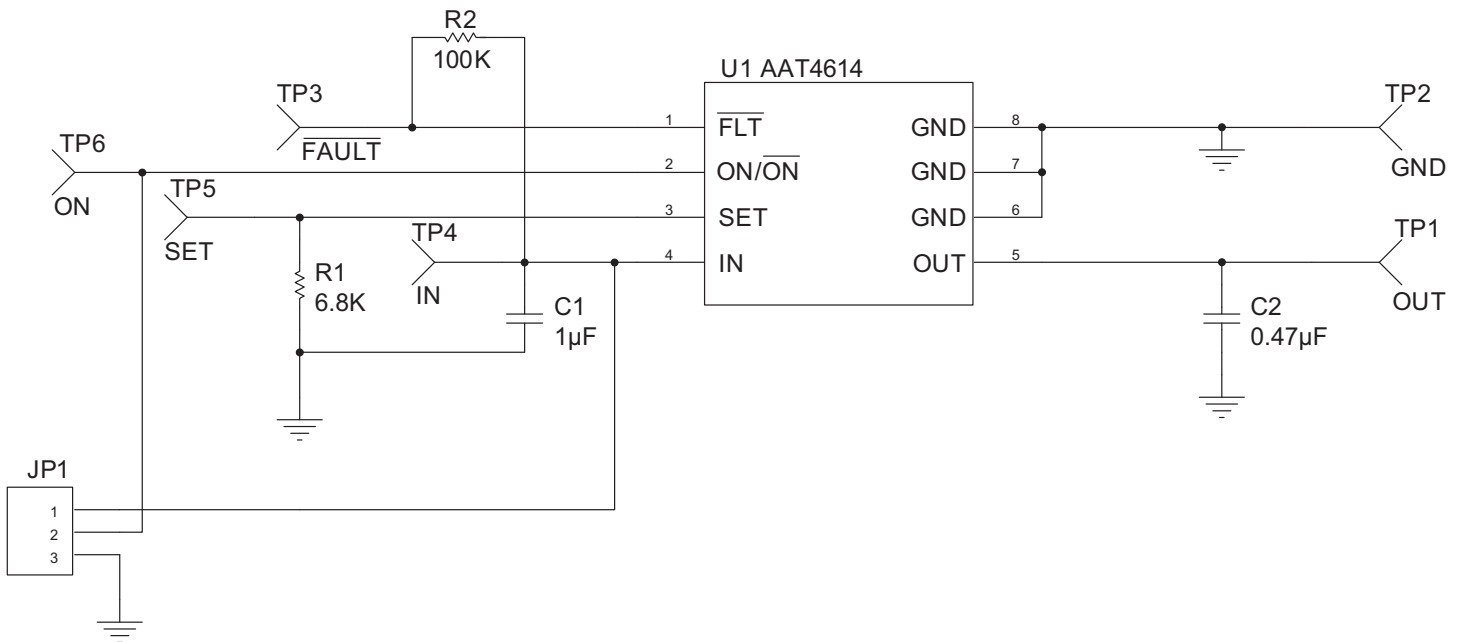

Figure 7: AAT4614 Evaluation Board for SC70JW-8 Package.

AAT4614**Adjustable Current Limited Load Switch with Fault Flag**

Component	Part Number	Description	Manufacturer
C1	GRM219R61A475KE19	CAP Ceramic 1 μ F 10V X5R 10% 0603	Murata
C2	GRM219R61A475KE19	CAP Ceramic 0.47 μ F10V X5R 10% 0805	Murata
JP1		Device Enable/Disable Selector	
R1	Chip Resistor	6.8K, 1/16W 1% 0603 SMD	Vishay
R2	Chip Resistor	100K, 1/16W 1% 0603 SMD	Vishay
R3	Chip Resistor	6.8K, 1/16W 1% 0603 SMD, for SOT23-5 package device only	Vishay
TP1	5010K-ND	OUT	Keystone
TP2	5011K-ND	GND	Keystone
TP3	5010K-ND	FAULT (SOT23-6) / SET (SOT23-5)	Keystone
TP4	5010K-ND	IN	Keystone
TP5	5010K-ND	SET (for SOT23-6 only)	Keystone
TP6	5010K-ND	ON/ $\overline{\text{ON}}$	Keystone
U1	AAT4614AI(GU/GV/JS)-(1/2)-T1	Load Switch	Skyworks

Table 2: AAT4614 Evaluation Board Bill of Materials (BOM).

AAT4614

Adjustable Current Limited Load Switch with Fault Flag

Ordering Information

Enable Input	Package	Marking ¹	Part Number (Tape and Reel) ²
Active High	SOT23-6	5BXY	AAT4614IGU-2-T1
Active High	SOT23-5	5CXY	AAT4614IGV-2-T1
Active Low	SOT23-6	8YXY	AAT4614IGU-1-T1
Active Low	SOT23-5	9GXY	AAT4614IGV-1-T1
Active Low	SC70JW-8		AAT4614IJS-1-T1
Active High	SC70JW-8	5DXY	AAT4614IJS-2-T1

 Skyworks Green™ products are compliant with all applicable legislation and are halogen-free. For additional information, refer to *Skyworks Definition of Green™*, document number SQ04-0074.

Package Information

SOT23-6

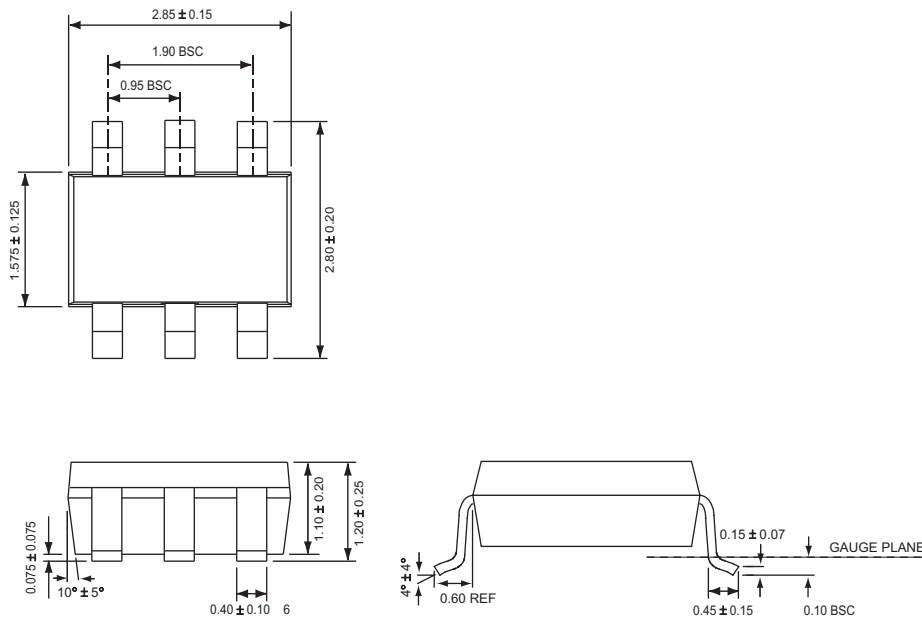

All dimensions in millimeters.

1. XYY = assembly and date code.
 2. Sample stock is generally held on part numbers listed in **BOLD**.

Adjustable Current Limited Load Switch with Fault Flag

SOT23-5

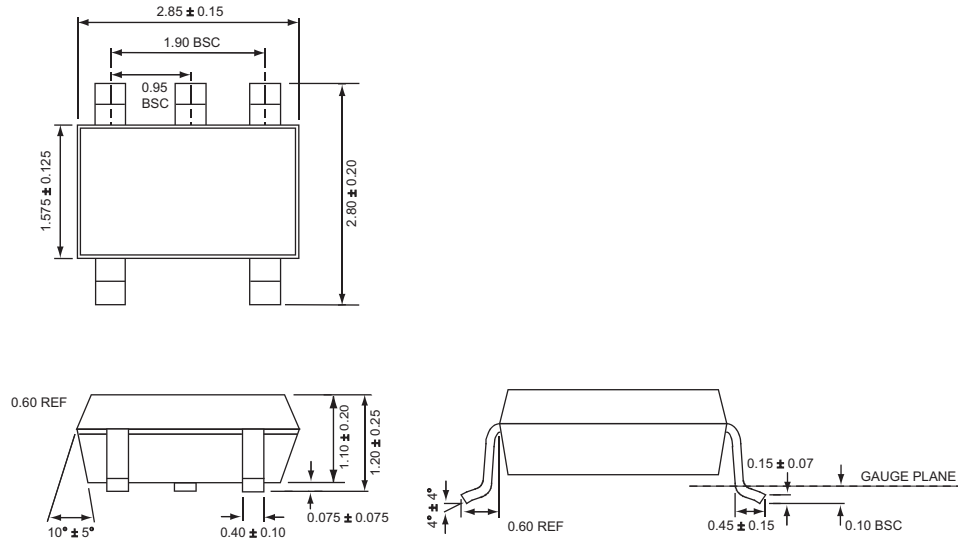

SC70JW-8

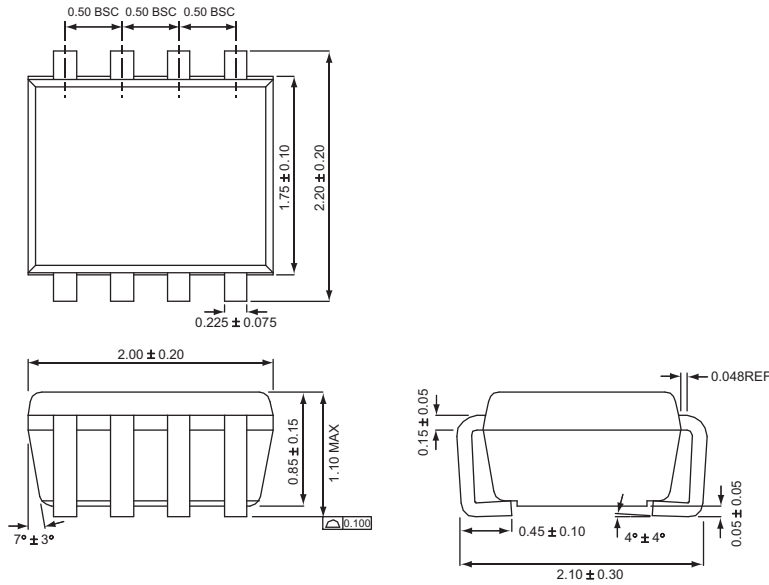

All dimensions in millimeters.

Adjustable Current Limited Load Switch with Fault Flag

Copyright © 2012 Skyworks Solutions, Inc. All Rights Reserved.

Information in this document is provided in connection with Skyworks Solutions, Inc. ("Skyworks") products or services. These materials, including the information contained herein, are provided by Skyworks as a service to its customers and may be used for informational purposes only by the customer. Skyworks assumes no responsibility for errors or omissions in these materials or the information contained herein. Skyworks may change its documentation, products, services, specifications or product descriptions at any time, without notice. Skyworks makes no commitment to update the materials or information and shall have no responsibility whatsoever for conflicts, incompatibilities, or other difficulties arising from any future changes.

No license, whether express, implied, by estoppel or otherwise, is granted to any intellectual property rights by this document. Skyworks assumes no liability for any materials, products or information provided hereunder, including the sale, distribution, reproduction or use of Skyworks products, information or materials, except as may be provided in Skyworks Terms and Conditions of Sale.

THE MATERIALS, PRODUCTS AND INFORMATION ARE PROVIDED "AS IS" WITHOUT WARRANTY OF ANY KIND, WHETHER EXPRESS, IMPLIED, STATUTORY, OR OTHERWISE, INCLUDING FITNESS FOR A PARTICULAR PURPOSE OR USE, MERCHANTABILITY, PERFORMANCE, QUALITY OR NON-INFRINGEMENT OF ANY INTELLECTUAL PROPERTY RIGHT; ALL SUCH WARRANTIES ARE HEREBY EXPRESSLY DISCLAIMED. SKYWORKS DOES NOT WARRANT THE ACCURACY OR COMPLETENESS OF THE INFORMATION, TEXT, GRAPHICS OR OTHER ITEMS CONTAINED WITHIN THESE MATERIALS. SKYWORKS SHALL NOT BE LIABLE FOR ANY DAMAGES, INCLUDING BUT NOT LIMITED TO ANY SPECIAL, INDIRECT, INCIDENTAL, STATUTORY, OR CONSEQUENTIAL DAMAGES, INCLUDING WITHOUT LIMITATION, LOST REVENUES OR LOST PROFITS THAT MAY RESULT FROM THE USE OF THE MATERIALS OR INFORMATION, WHETHER OR NOT THE RECIPIENT OF MATERIALS HAS BEEN ADVISED OF THE POSSIBILITY OF SUCH DAMAGE.

Skyworks products are not intended for use in medical, lifesaving or life-sustaining applications, or other equipment in which the failure of the Skyworks products could lead to personal injury, death, physical or environmental damage. Skyworks customers using or selling Skyworks products for use in such applications do so at their own risk and agree to fully indemnify Skyworks for any damages resulting from such improper use or sale.

Customers are responsible for their products and applications using Skyworks products, which may deviate from published specifications as a result of design defects, errors, or operation of products outside of published parameters or design specifications. Customers should include design and operating safeguards to minimize these and other risks. Skyworks assumes no liability for applications assistance, customer product design, or damage to any equipment resulting from the use of Skyworks products outside of stated published specifications or parameters.

Skyworks, the Skyworks symbol, and "Breakthrough Simplicity" are trademarks or registered trademarks of Skyworks Solutions, Inc., in the United States and other countries. Third-party brands and names are for identification purposes only, and are the property of their respective owners. Additional information, including relevant terms and conditions, posted at www.skyworksinc.com, are incorporated by reference.