

Incremental encoders

Shaft $\varnothing 11$ mm with EURO flange

Resolution 200...2048 pulses

ITD 40 B10 Y 4



ITD 40 B10 Y 4 with EURO flange

Technical data - electrical ratings

Voltage supply	5 VDC ± 5 % 8...30 VDC
Reverse polarity protection	Yes
Consumption w/o load	≤ 100 mA
Resolution (steps/turn)	200...2048
Reference signal	Zero pulse, width 90°
Sensing method	Optical
Output frequency	≤ 120 kHz
Output signals	A, B, N + inverted
Output circuit	TTL linedriver (short-circuit proof) HTL push-pull (short-circuit proof)
Interference immunity	DIN EN 61000-6-2
Emitted interference	DIN EN 55011

Features

- Encoder with shaft $\varnothing 11$ mm
- Resolution max. 2048 ppr
- Optical sensing
- Centering alignment $\varnothing 85$ mm, mounting screw hole circle $\varnothing 100$ mm
- Industrial standard with centering flange
- Dual bearing
- TTL or HTL output signals
- Flange socket radial or axial

Optional

- Extended operating temperature range

Technical data - mechanical design

Dimensions (flange)	$\varnothing 82$ mm
Shaft	$\varnothing 11$ mm
Shaft loading	≤ 60 N axial ≤ 100 N radial
Flange	EURO flange B10
Protection DIN EN 60529	IP 65
Operating speed	≤ 8000 rpm
Starting torque	≤ 0.015 Nm
Materials	Housing: aluminium Shaft: stainless steel
Operating temperature	$-20...+70$ °C $-20...+100$ °C
Relative humidity	90 % non-condensing
Resistance	DIN EN 60068-2-6 Vibration 10 g, 55-2000 Hz DIN EN 60068-2-27 Shock 100 g, 11 ms
Connection	Connector M23 type 2, 12-pin
Weight approx.	950 g

Incremental encoders

Shaft $\varnothing 11$ mm with EURO flange
Resolution 200...2048 pulses

ITD 40 B10 Y 4

Output signals

Clockwise rotation when looking at the mounting side.

BI-Output signals

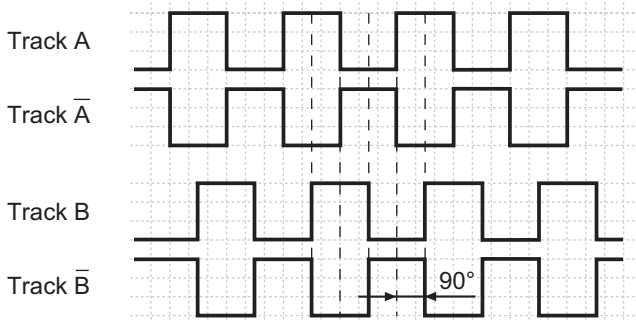

NI-Output signals

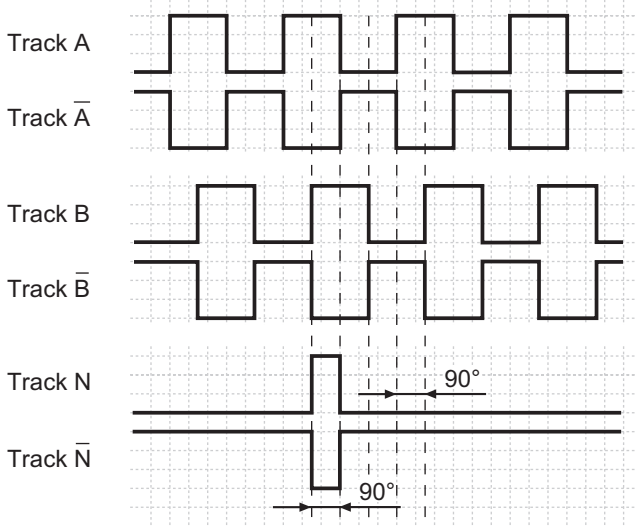

Terminal assignment

Connector	Assignment
Pin 5	Track A
Pin 6	Track A inv.
Pin 8	Track B
Pin 1	Track B inv.
Pin 3	Track N
Pin 4	Track N inv.
Pin 12	UB
Pin 10	GND
Pin 2	UB-Sense
Pin 11	GND-Sense
Pin 9	-
Pin 7	-

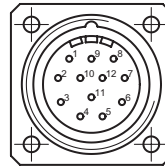

Trigger level

Outputs	Linedriver
Output level High	≥ 2.4 V
Output level Low	≤ 0.5 V
Load	≤ 70 mA

Outputs	Push-pull short-circuit proof
Output level High	$\geq UB - 3$ V
Output level Low	≤ 1.5 V
Load	≤ 70 mA

Incremental encoders

Shaft $\varnothing 11$ mm with EURO flange
Resolution 200...2048 pulses

ITD 40 B10 Y 4

Dimensions

