

Incremental encoders

End shaft $\varnothing 20$ to $\varnothing 27$ mm

Resolution 200...2048 pulses

ITD 40 A 4 Y141



ITD 40 A 4 Y141 with end shaft

Features

- Encoder with end shaft $\varnothing 20$ -27 mm
- Resolution max. 2048 ppr
- Optical sensing
- NIRO design
- Mounting by torque support
- TTL or HTL output signals
- Cable output radial
- High protection standard

Optional

- Cable with connector

Technical data - electrical ratings

Voltage supply	5 VDC ± 5 % 8...30 VDC
Reverse polarity protection	Yes
Consumption w/o load	≤ 100 mA
Resolution (steps/turn)	200...2048
Reference signal	Zero pulse, width 90°
Sensing method	Optical
Output frequency	≤ 120 kHz
Output signals	A, B, N + inverted
Output circuit	TTL linedriver (short-circuit proof) HTL push-pull (short-circuit proof)
Interference immunity	DIN EN 61000-6-2
Emitted interference	DIN EN 55011

Technical data - mechanical design

Dimensions (flange)	$\varnothing 89$ mm
Shaft	$\varnothing 20$ mm end shaft $\varnothing 22$ mm end shaft $\varnothing 25$ mm end shaft $\varnothing 27$ mm end shaft
Motor shaft tolerance	0.25 mm axial 0.1 mm radial
Mounting kit variant	081
Protection DIN EN 60529	IP 67
Operating speed	≤ 2500 rpm
Starting torque	≤ 0.2 Nm
Materials	Housing: stainless steel Shaft: stainless steel
Operating temperature	$-20 \dots +70$ °C
Relative humidity	90 % non-condensing
Resistance	DIN EN 60068-2-6 Vibration 10 g, 55-2000 Hz DIN EN 60068-2-27 Shock 100 g, 11 ms
Connection	Cable 1 m
Weight approx.	1850 g

Incremental encoders

End shaft $\varnothing 20$ to $\varnothing 27$ mm

Resolution 200...2048 pulses

ITD 40 A 4 Y141

Part number

ITD 40 A 4 Y141

			KR1	S		IP67	081
--	--	--	-----	---	--	------	-----

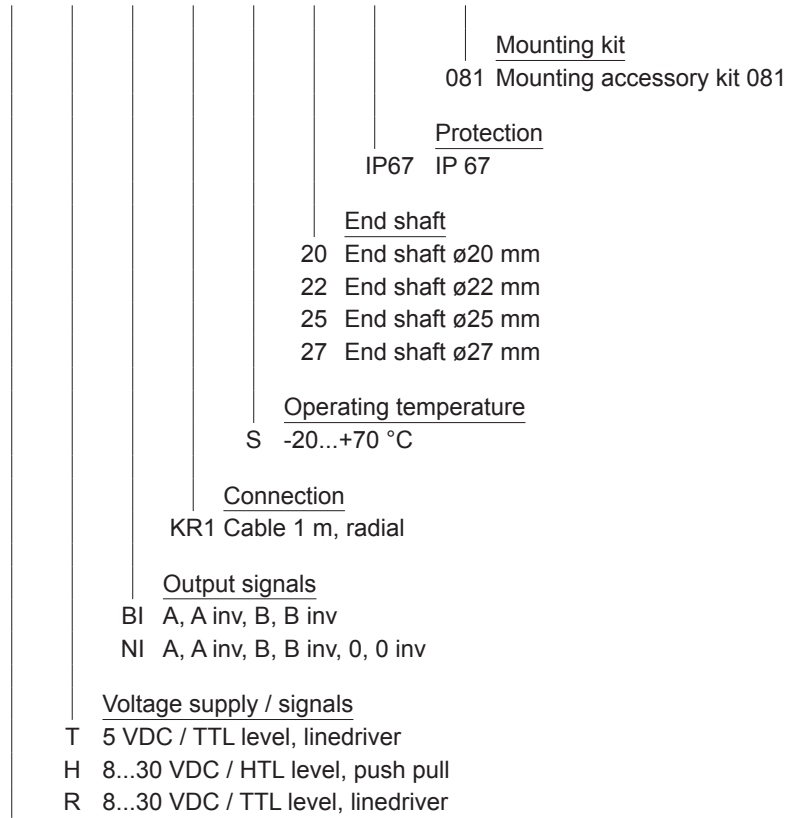

See part number (pulses)

Part number (pulses)

200	500	720	1024	2048
360	512	1000	2000	

Incremental encoders

End shaft $\varnothing 20$ to $\varnothing 27$ mm

Resolution 200...2048 pulses

ITD 40 A 4 Y141

Output signals

Clockwise rotation when looking at the mounting side.

BI-Output signals

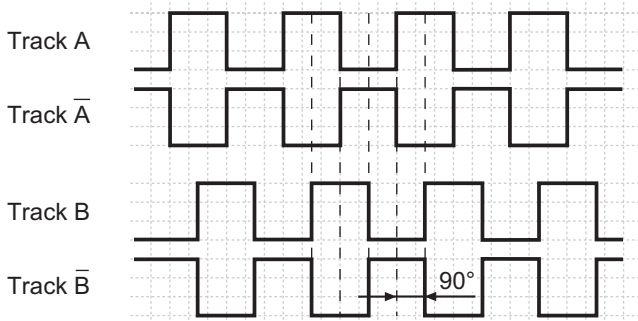

NI-Output signals

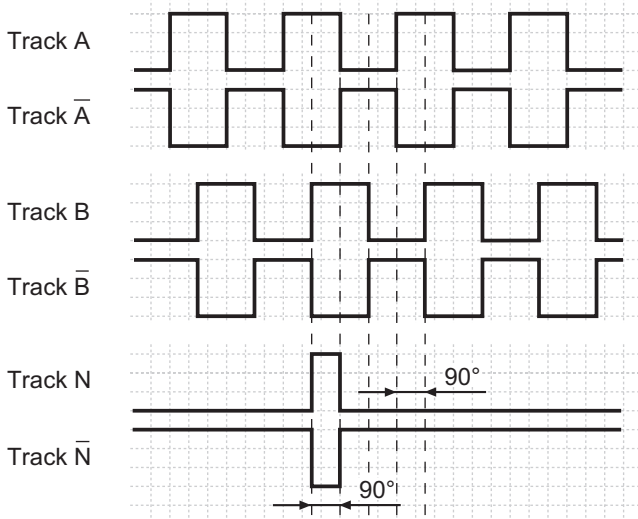

Terminal assignment

Core colour	Assignment
green	Track A
yellow	Track A inv.
grey	Track B
pink	Track B inv.
brown	Track N
white	Track N inv.
rot	UB
blue	GND
violet	UB-Sense
black	GND-Sense
transparent	Shield/Housing

Trigger level

Outputs	Linedriver
Output level High	≥ 2.4 V
Output level Low	≤ 0.5 V
Load	≤ 70 mA

Outputs	Push-pull short-circuit proof
Output level High	$\geq UB - 3$ V
Output level Low	≤ 1.5 V
Load	≤ 70 mA

Dimensions

mounting side
(proposition)

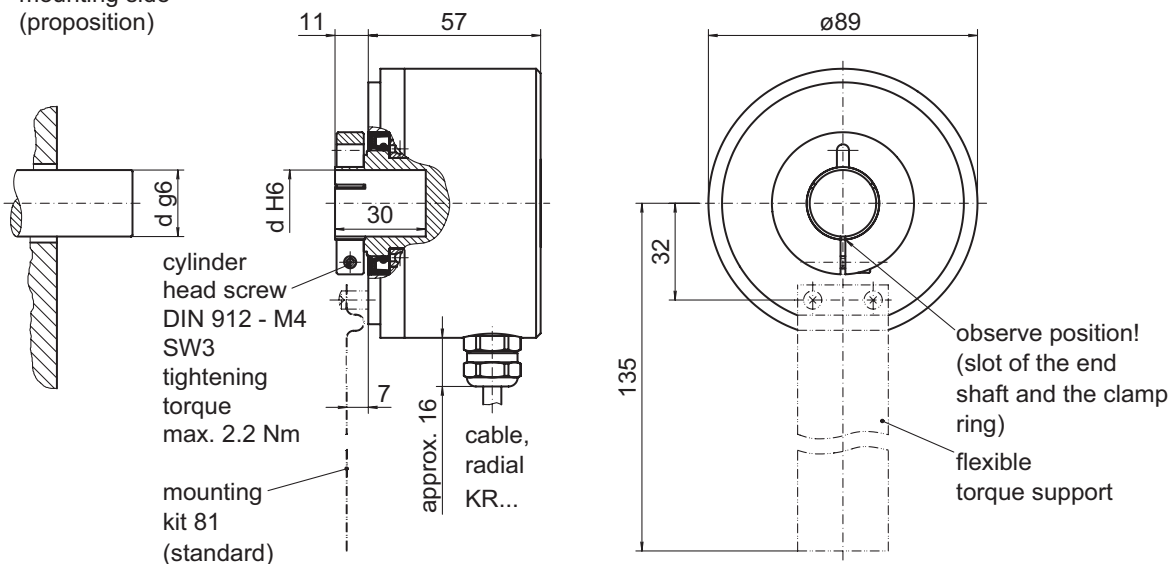

026- 5 Y141

Incremental encoders

End shaft $\varnothing 20$ to $\varnothing 27$ mm

Resolution 200...2048 pulses

ITD 40 A 4 Y141