

Incremental encoders

End shaft $\varnothing 10$ to $\varnothing 14$ mm

Resolution 100...6000 pulses

ITD 21 A 4 Y21



ITD 21 A 4 Y21 with end shaft

Features

- Encoder with end shaft $\varnothing 10$ -14 mm
- Resolution max. 6000 ppr
- Optical sensing
- Mounting by torque support
- TTL or HTL output signals
- Cable output radial
- High protection standard

Optional

- Cable with connector

Technical data - electrical ratings

Voltage supply	5 VDC ± 5 % 8...30 VDC
Reverse polarity protection	Yes
Consumption w/o load	≤ 100 mA
Resolution (steps/turn)	100...6000
Reference signal	Zero pulse, width 90°
Sensing method	Optical
Output frequency	≤ 300 kHz (TTL) ≤ 160 kHz (HTL)
Output signals	A, B, N + inverted
Output circuit	TTL linedriver (short-circuit proof) HTL push-pull (short-circuit proof)
Interference immunity	DIN EN 61000-6-2
Emitted interference	DIN EN 55011

Technical data - mechanical design

Dimensions (flange)	$\varnothing 58$ mm
Shaft	$\varnothing 10$ mm end shaft $\varnothing 12$ mm end shaft $\varnothing 14$ mm end shaft
Motor shaft tolerance	0.25 mm axial 0.1 mm radial
Mounting kit variant	002
Protection DIN EN 60529	IP 65
Operating speed	≤ 8000 rpm ≤ 5000 rpm IP 65 ($>70^\circ\text{C}$)
Starting torque	≤ 0.01 Nm
Materials	Housing: aluminium, black, powder-coated Shaft: stainless steel
Operating temperature	$-20...+70^\circ\text{C}$ $-20...+100^\circ\text{C}$
Relative humidity	90 % non-condensing
Resistance	DIN EN 60068-2-6 Vibration 10 g, 55-2000 Hz DIN EN 60068-2-27 Shock 100 g, 11 ms
Connection	Cable 1 m
Weight approx.	260 g

Incremental encoders

End shaft $\varnothing 10$ to $\varnothing 14$ mm

Resolution 100...6000 pulses

ITD 21 A 4 Y21

Part number

ITD 21 A 4 Y21

		NI	KR1			IP65	002
--	--	----	-----	--	--	------	-----

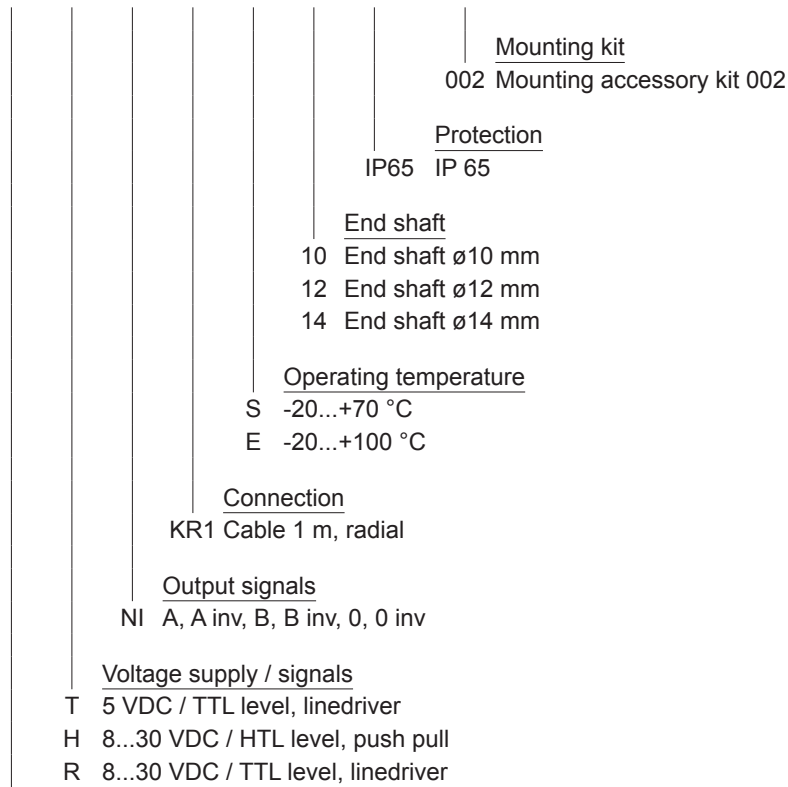

See part number (pulses)

Part number (pulses)

100	360	900	1800	4096
120	400	1000	2000	5000
150	500	1024	2048	6000
200	512	1200	2500	
250	600	1250	3000	
256	720	1440	3600	
300	800	1500	4000	

Incremental encoders

End shaft $\varnothing 10$ to $\varnothing 14$ mm

Resolution 100...6000 pulses

ITD 21 A 4 Y21

Output signals

Clockwise rotation when looking at the mounting side.

NI-Output signals

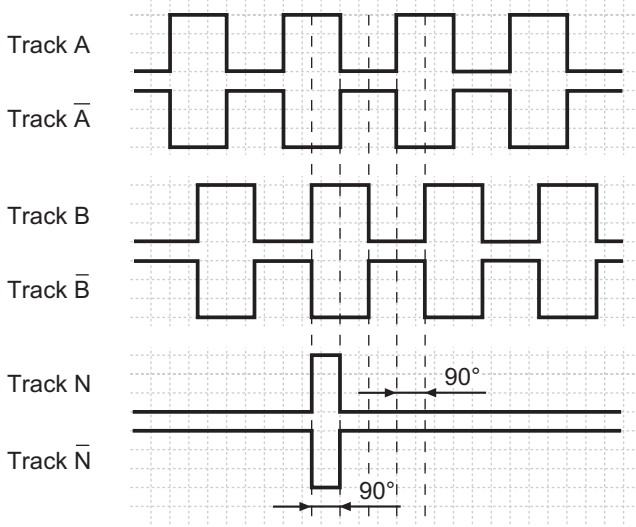

Terminal assignment

Core colour	Assignment
brown	Track A
green	Track A inv.
grey	Track B
pink	Track B inv.
red	Track N
black	Track N inv.
brown 0,5 mm ²	UB
white 0,5 mm ²	GND
blue	UB-Sense
white	GND-Sense
transparent	Shield/Housing

Trigger level

Outputs	Linedriver
Output level High	≥ 2.4 V
Output level Low	≤ 0.5 V
Load	≤ 70 mA

Outputs	Push-pull short-circuit proof
Output level High	$\geq UB - 3$ V
Output level Low	≤ 1.5 V
Load	≤ 70 mA

Dimensions

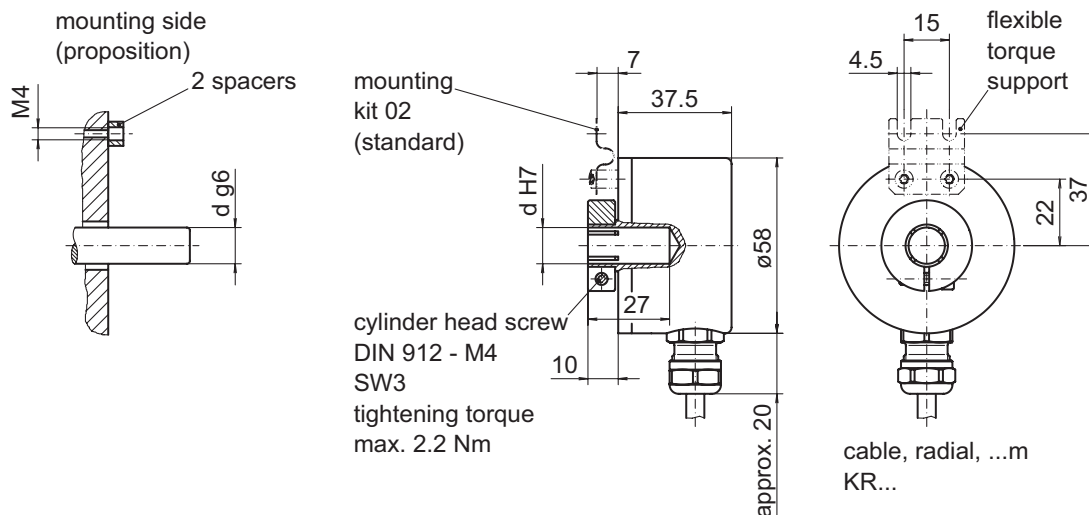

029- 1 Y21

Incremental encoders

End shaft \varnothing 10 to \varnothing 14 mm

Resolution 100...6000 pulses

ITD 21 A 4 Y21