

General Description

The AAT4650 SmartSwitch is a single channel PC card (PCMCIA) power switch. It is used to select between two different voltage inputs, each between 2.7V and 5.5V. An internal switch powers the circuitry from whichever input voltage is higher. The device's output, V_{CC} , is slew rate controlled and current limited, in compliance with PC card specifications. The current limit response time to a short circuit is typically 1 μ s. The internal P-channel MOSFET switches are configured to break before make; that is, both switches cannot be closed at the same time. Controlled by a 2-bit parallel interface, the four states for V_{CC} are V_{CC5} , V_{CC3} , high impedance, or ground. When in the ground state, V_{CC} is pulled to ground by a 5k Ω resistor. An open drain $\overline{\text{FAULT}}$ output is asserted during over-current conditions. During power-up slewing, $\overline{\text{FAULT}}$ also signals that V_{CC} is out of tolerance. An internal over-temperature sensor forces V_{CC} to a high impedance state when an over-temperature condition exists. Quiescent current is typically a low 15 μ A, as long as I_{CC} is less than approximately 500mA. Above this load current, the quiescent current increases to 200 μ A.

The AAT4650 is available in a Pb-free, 8-pin SOP package and is specified over the -40 $^{\circ}$ C to +85 $^{\circ}$ C temperature range.

Features

- 2.7V to 5.5V Input Voltage Range
- 80m Ω (5V) Typical $R_{DS(ON)}$
- Low Quiescent Current 15 μ A (typ)
- Reverse-Blocking Switches
- Short-Circuit Protection
- Over-Temperature Protection
- $\overline{\text{FAULT}}$ Flag Output
- Temperature Range: -40 $^{\circ}$ C to +85 $^{\circ}$ C
- 8-Pin SOP Package

Applications

- Notebook Computer
- PDA, Subnotebook
- Power Supply Multiplexer Circuit

Typical Application

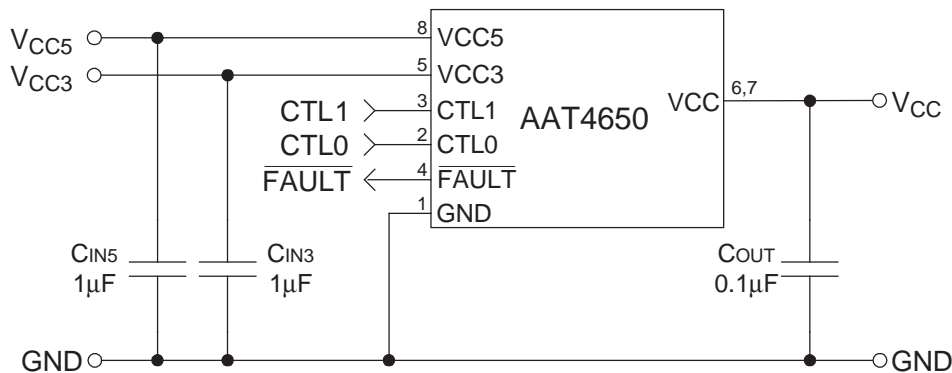

DATA SHEET

AAT4650

5V/3V PC Card Power Switch

Pin Descriptions

Pin #	Symbol	Function
1	GND	Ground connection.
2	CTL0	Control input (see Control Logic Table below).
3	CTL1	Control input (see Control Logic Table below).
4	FAULT	Open drain output; signals over-current condition.
5	VCC3	3V supply.
6, 7	VCC	Output (see Control Logic Table below).
8	VCC5	5V supply.

Pin Configuration

SOP-8
(Top View)

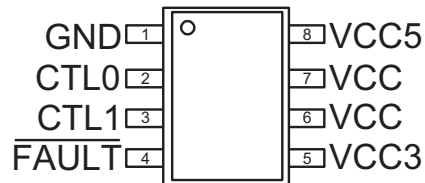

Control Logic Table

CTL1	CTL0	Function	Result
0	0	5k	VCC to GND
0	1	5V	VCC = VCC5
1	0	3V	VCC = VCC3
1	1	HiZ	Both FETs OFF

Absolute Maximum Ratings¹

Symbol	Description	Value	Units
V_{CC3}, V_{CC5}	IN to GND	-0.3 to 6	V
V_{CC}	OUT to GND	-0.3 to 6	V
I_{MAX}	Maximum Continuous Switch Current	Current Limited	A
T_J	Operating Junction Temperature Range	-40 to 150	°C
T_{LEAD}	Maximum Soldering Temperature (at Leads)	300	°C
V_{ESD}	ESD Rating ² — HBM	4000	V

Thermal Characteristics³

Symbol	Description	Value	Units
Θ_{JA}	Thermal Resistance	120	°C/W
P_D	Power Dissipation	1.0	W

1. Stresses above those listed in Absolute Maximum Ratings may cause permanent damage to the device. Functional operation at conditions other than the operating conditions specified is not implied.
2. Human body model is a 100pF capacitor discharged through a 1.5kΩ resistor into each pin.
3. Mounted on an FR4 board.

DATA SHEET

AAT4650

5V/3V PC Card Power Switch

Electrical Characteristics

$V_{IN} = 5V$, $T_A = -40^{\circ}C$ to $+85^{\circ}C$, unless otherwise noted. Typical values are at $T_A = 25^{\circ}C$; **bold** values designate full temperature range.

Symbol	Description	Conditions	Min	Typ	Max	Units
V_{CC} Output						
I _{CC} Hi-Z	High Impedance Output Leakage Current	Off Mode, V _{CC} = 0V			1	μA
I _{CCSC}	Short-Circuit Current Limit	V _{CC} = V _{CCIN} -0.5V, On Mode V _{CC3} or V _{CC5} Selected, T _A = 25°C	1.0		2.5	A
R _{DS(ON)}	On Resistance	V _{CC} = 3.0V, T _A = 25°C V _{CC} = 5.0V, T _A = 25°C		85 80	110 100	mΩ
T _{crds}	Switch Resistance Temperature Coefficient			2800		ppm/°C
V_{CC} Switching Time (Refer to Figure 1)						
t1	Output Turn-On Delay Time	V _{CC} = 0V to 10% of 3.3V, R _{OUT} = 10Ω		500	2000	μs
t2	Output Turn-On Delay Time	V _{CC} = 0V to 10% of 5.0V, R _{OUT} = 10Ω		500	1500	
t3	Output Rise Time	V _{CC} = 10% to 90% of 3.3V, R _{LOAD} = 10Ω	300	1000	3000	
t4	Output Rise Time	V _{CC} = 10% to 90% of 5.0V, R _{LOAD} = 10Ω	300	1000	3000	
t5	Output Turn-Off Delay Time	V _{CC} = 3.3V to 90% of 3.3V, R _{LOAD} = 10Ω			400	
t6	Output Turn-Off Delay Time	V _{CC} = 5.0V to 90% of 5.0V, R _{LOAD} = 10Ω			400	
t7	Output Fall Time to Off State	V _{CC} = 90% to 10% of 3.3V, R _{LOAD} = 10Ω			200	
t8	Output Fall Time to Off State	V _{CC} = 90% to 10% of 5.0V, R _{LOAD} = 10Ω			200	
t9	Output Fall Time to HiZ State	V _{CC} = 90% to 10% of 3.3V, R _{LOAD} = 10Ω			1500	
t10	Output Fall Time to HiZ State	V _{CC} = 90% to 10% of 5.0V, R _{LOAD} = 10Ω			2000	
Power Supply						
V _{CC3}	V _{CC3} Operation Voltage		2.7		5.5	V
V _{CC5}	V _{CC5} Operation Voltage		2.7		5.5	V
I _{CC3}	V _{CC3} Supply Current	V _{CC} = 5V or HiZ or Off, V _{CC3} < V _{CC5} , I _{CC} Out = 0 V _{CC} = 3.3V, V _{CC3} < V _{CC5} , I _{CC} Out = 0		5	1 20	μA
I _{CC5}	V _{CC5} Supply Current	V _{CC} = Off, V _{CC5} > V _{CC3} , I _{CC} Out = 0 V _{CC} = HiZ, V _{CC5} > V _{CC3} , I _{CC} Out = 0 V _{CC} = 3.3V, V _{CC5} > V _{CC3} , I _{CC} Out = 0 V _{CC} = 5V, V _{CC5} > V _{CC3} , I _{CC} Out = 0		10 10 15	1 40 40 40	μA
Parallel Interface						
V _{CTLLOW}	CTL Input Low Voltage				0.8	V
V _{CTLHI}	CTL Input High Voltage	V _{CC3} or V _{CC5} = 2.7V to 3.6V V _{CC3} or V _{CC5} = 4.5V to 5.5V	2.0 2.4			V
I _{SINKCTL}	CTL Input Leakage	V _{CTL} = 5.5V		0.01	1	μA
V _{FAULTLOW}	FAULT Logic Output Low Voltage	I _{SINK} = 1mA			0.4	V
I _{SINKFAULT}	FAULT Logic Output High Leakage Current	V _{FAULT} = 5.5V		0.05	1	μA
Other						
OTMP	Over-Temperature Shutdown			125		°C

DATA SHEET

AAT4650

5V/3V PC Card Power Switch

Typical Characteristics

Unless otherwise noted, $T_A = 25^\circ\text{C}$.

Quiescent Current vs. Temperature
(I_{CC5})

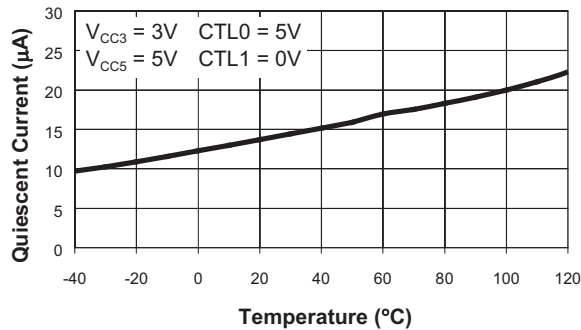

Current Limit
($V_{CC} = V_{CC3}$)

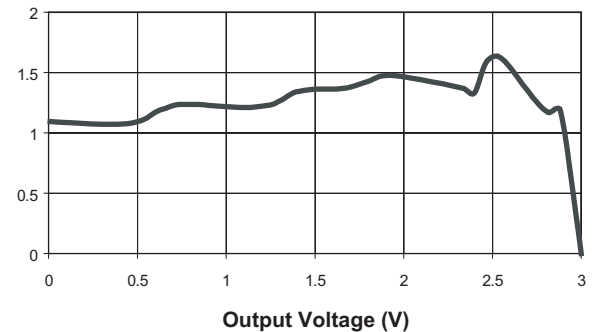

Current Limit
($V_{CC} = V_{CC5}$)

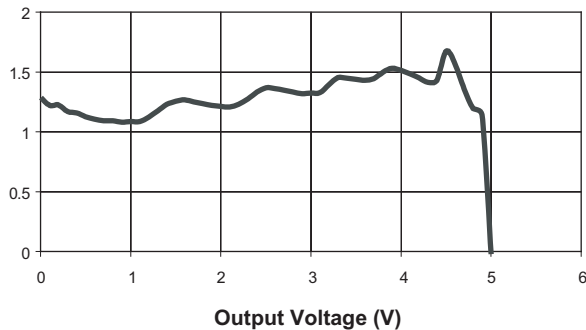

Off-Switch Current vs. Temperature
(I_{CC3})

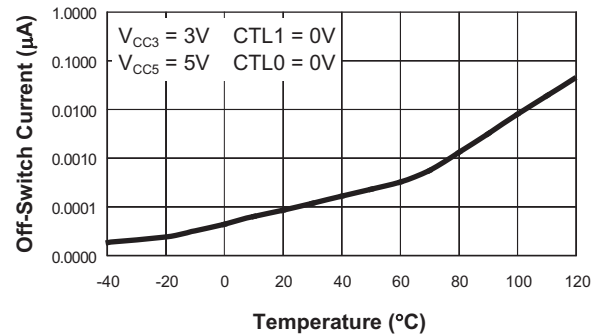

Off-Switch Current vs. Temperature
(I_{CC3})

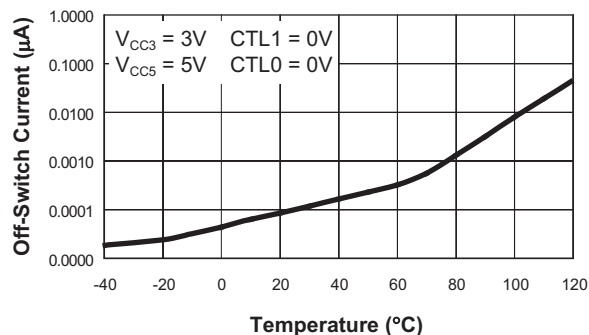

$R_{DS(ON)}$ vs. Temperature

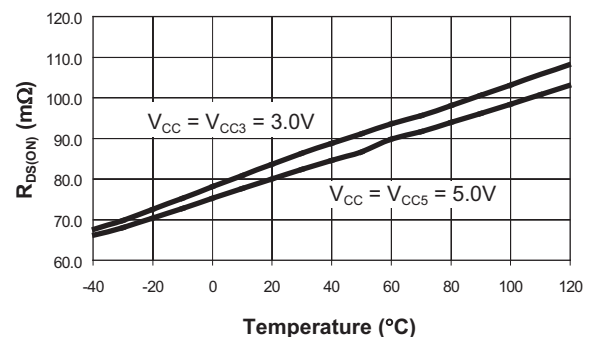

Typical Characteristics

Unless otherwise noted, $T_A = 25^\circ\text{C}$.

Turn-On/Off Response
(10 Ω , 1 μF Load)

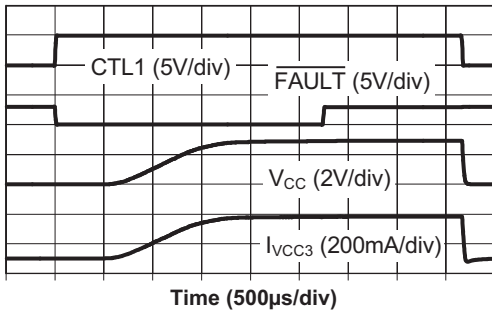

Turn-On/Off Response
(15 Ω , 1 μF Load)

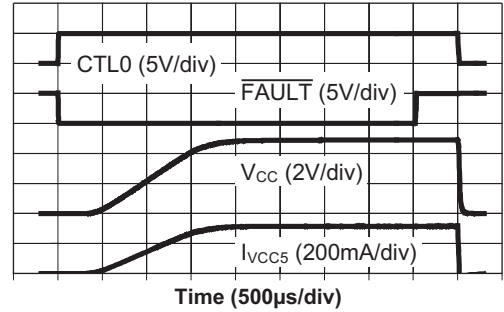

Short Circuit Through 0.3 Ω

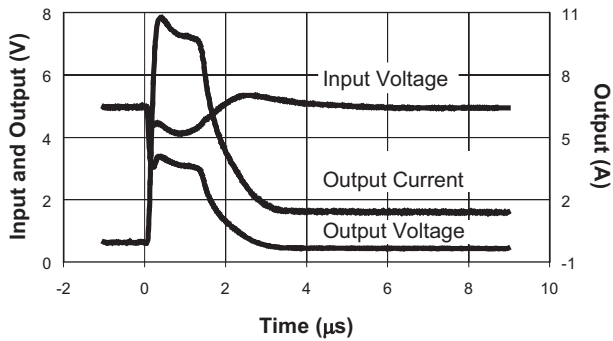

Short Circuit Through 0.6 Ω

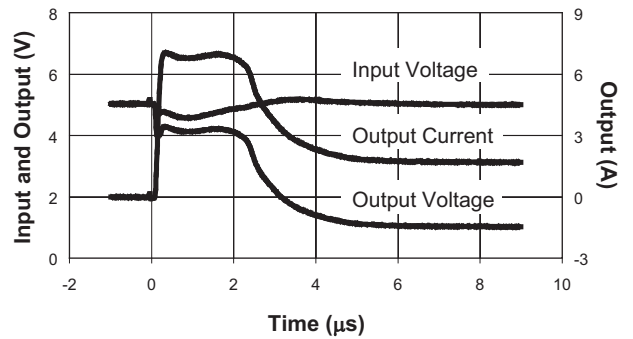

Thermal Shutdown Response

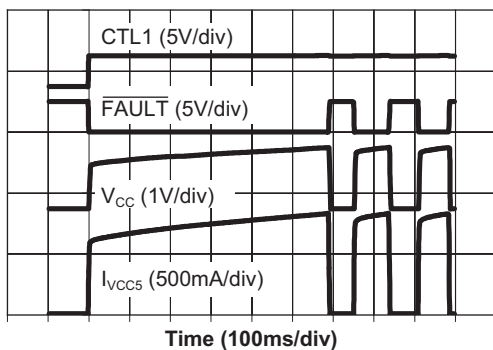

Functional Block Diagram

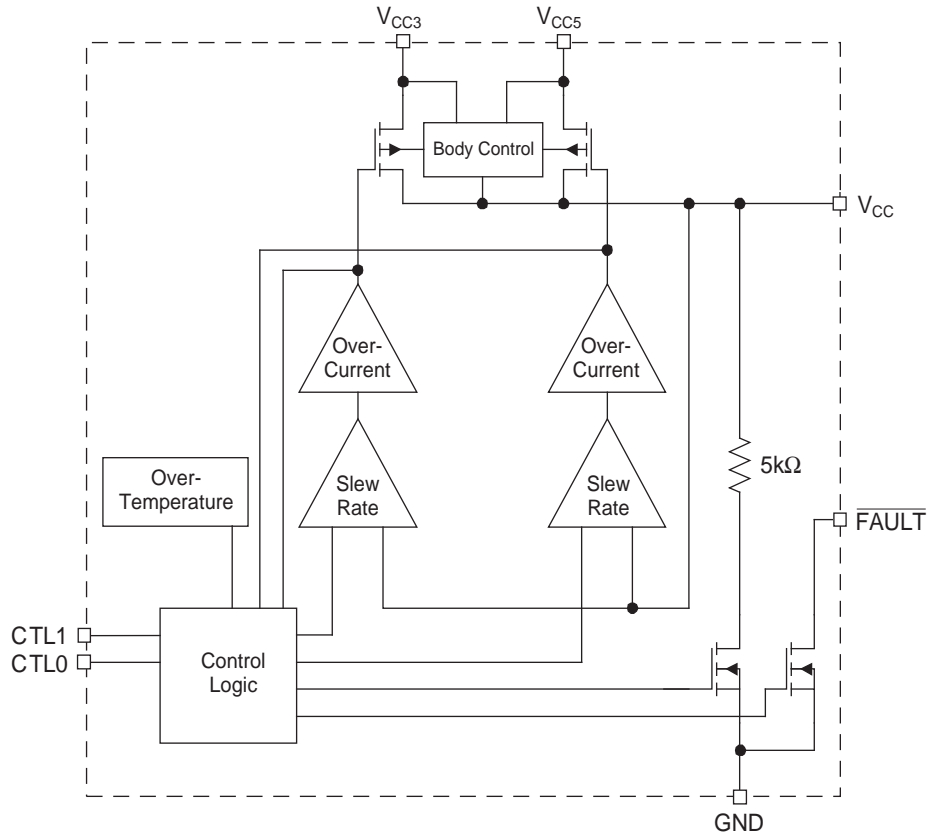

Functional Description

The AAT4650 is a single channel power switch that can be used in any application where dual power supply multiplexing is required. Typical applications include PC card applications not requiring a 12V power supply, or applications where power is switched, for example, between 5V for operation and 3.3V for standby mode. The AAT4650 operates with input voltages ranging from 2.7V to 5.5V in any combination and automatically powers its internal circuitry off of whichever input voltage is higher. Two identical low $R_{DS(ON)}$ P-channel MOSFETs serve as the power multiplexing circuit with a common drain as the V_{CC} output and independent sources as the two V_{CC3} and V_{CC5} inputs. A 2-bit parallel interface determines the state of the multiplexer: $V_{CC} = V_{CC3}$, $V_{CC} = V_{CC5}$, V_{CC} with resistive pull down to ground, or V_{CC} high impedance. When the state is set to either of the two inputs, the multiplex-

ing circuit will slowly slew the V_{CC} output to the new voltage level which protects the upstream power supply from sudden load transients. When the resistive pull down is chosen for V_{CC} , the V_{CC} output is quickly discharged by the resistive pull down. The AAT4650 always serves as an electronic fuse by limiting the load current if it exceeds the current limit threshold. During power-up into a short, the current will gradually increase until the current limit is reached. During a sudden short circuit on the output, the current limit will respond in 1 μ s to isolate and protect the upstream power supply from the load short circuit. In most applications, because the response time is so fast, a short circuit to V_{CC} will not affect the upstream supply, so system functionality will not be affected. In the case of an over-current condition, an open drain \overline{FAULT} flag output will signal the event. The \overline{FAULT} output is also active during output voltage slew, and becomes inactive once the output is within regulation.

5V/3V PC Card Power Switch

Applications Information

Input Capacitor

A 1μF or larger capacitor is typically recommended for C_{IN}. A C_{IN} capacitor is not required for basic operation; however, it is useful in preventing load transients from affecting up-stream circuits. C_{IN} should be located as close to the device VIN pin as practically possible. Ceramic, tantalum, or aluminum electrolytic capacitors may be selected for C_{IN}. There is no specific capacitor equivalent series resistance (ESR) requirement for C_{IN}. However, for higher current operation, ceramic capacitors are recommended for C_{IN} due to their inherent capability over tantalum capacitors to withstand input current surges from low impedance sources such as batteries in portable devices.

Output Capacitor

A 0.1μF or greater capacitor is generally required between V_{CC} and GND. Likewise, with the output capacitor, there is no specific capacitor ESR requirement. If desired, C_{OUT} may be increased to accommodate any load transient condition.

Parallel Interface / Break Before Make

A 2-bit parallel interface determines the state of the V_{CC} output. The logic levels are compatible with CMOS or TTL logic. A logic low value must be less than 0.8V, and a logic high value must be greater than 2.4V. In cases where the interface pins rapidly change state directly from 3V to 5V (or vice versa), internal break-before-make circuitry prevents any back flow of current from one input power supply to the other. In addition, the body connections of the internal P-channel MOSFET switches are always set to the highest potential of V_{CC3}, V_{CC5}, or V_{CC}, which prevents any body diode conduction, power supply backflow, or possible device damage.

FAULT Output

The FAULT output is pulled to ground by an open drain N-channel MOSFET during an over-current or output slew condition. It should be pulled up to the reference power supply of the controller IC via a nominal 100kΩ resistor.

Voltage Regulation

The PC card specification calls for a regulated 5V supply tolerance of ±5%. Of this, a typical power supply will drop less than 2% and the PCB traces will drop another 1%. This leaves 2% for the AAT4650 as the PC card

switch. In the PC card application, the maximum allowable current for the AAT4650 is dominated by voltage regulation, rather than by thermal considerations, and is set by either the current limit or the maximum R_{DS(ON)} of the P-channel MOSFET. The maximum R_{DS(ON)} at 85°C is calculated by applying the R_{DS} temperature coefficient to the maximum room temperature R_{DS(ON)}:

$$R_{DS(ON)(MAX)} = R_{DS(ON)25} \times (1 + [TC \cdot \Delta T])$$

-or-

$$R_{DS(ON)(MAX)} = 100m\Omega (1 + [0.0028 \cdot 60]) = 116.8m\Omega$$

The maximum current is equal to the 2% tolerance of the 5V supply (100mV) across the AAT4650 divided by R_{DS(ON)(MAX)}. Or:

$$I_{MAX5} = \frac{100mV}{116.8m\Omega} = 856.2mA$$

For the 3.3V supply in the PC card application, the conditions are a bit relaxed, with the allowable voltage regulation drop equal to 300mV. With a 2% supply and 1% PCB trace regulation, the PC card switch can have a 200mV drop. So:

$$I_{MAX3} = \frac{200mV}{134m\Omega} = 1.5A$$

Since 1.5A is the nominal current limit value, the AAT4650 will current limit before I_{MAX3} is reached.

Thermal issues are not a problem in the SOP-8 package since θ_{JA}, the package thermal resistance, is only 120°C/W. At any given ambient temperature (T_A) the maximum package power dissipation can be determined by the following equation:

$$P_{D(MAX)} = \frac{T_{J(MAX)} - T_A}{\theta_{JA}}$$

Constants for the AAT4650 are maximum junction temperature, T_{J(MAX)} = 125°C, and package thermal resistance, θ_{JA} = 120°C/W. Worst case conditions are calculated at the maximum operating temperature where T_A = 85°C. Typical conditions are calculated under normal ambient conditions where T_A = 25°C. At T_A = 85°C, P_{D(MAX)} = 333mW. At T_A = 25°C, P_{D(MAX)} = 833mW.

Maximum current is given by the following equation:

$$I_{OUT(MAX)} = \sqrt{\frac{P_{D(MAX)}}{R_{DS(ON)}}}$$

For the AAT4650 at 85°C, I_{OUT(MAX)} = 1.65A, a value greater than the internal minimum current limit specification.

5V/3V PC Card Power Switch**Over-Current and Over-Temperature Protection**

Because many AAT4650 applications provide power to external devices, it is designed to protect its host device from malfunctions in those peripherals through slew rate control, current limiting, and thermal limiting. The AAT4650 current limit and thermal limit serve as an immediate and reliable electronic fuse without any increase in $R_{DS(ON)}$ for this function. Other solutions, such as a poly fuse, do not protect the host power supply and system from mishandling or short circuiting peripherals; they will only prevent a fire. The AAT4650 high-speed current limit and thermal limit not only prevent fires, they also isolate the power supply and entire system from any activity at the external port and report a mishap by means of a \overline{FAULT} signal.

Over-current and over-temperature go hand in hand. Once an over-current condition exists, the current supplied to the load by the AAT4650 is limited to the over-current threshold. This results in a voltage drop across the AAT4650 which causes excess power dissipation and a package temperature increase. As the die begins to heat up, the over-temperature circuit is activated. If the temperature reaches the maximum level, the AAT4650 automatically switches off the P-channel MOSFETs. While they are off, the over-temperature circuit remains active. Once the temperature has cooled by approximately 10°C, the P-channel MOSFETs are switched back on. In this manner, the AAT4650 is thermally cycled on and off until the short circuit is removed. Once the short is removed, normal operation automatically resumes.

To save power, the full high-speed over-current circuit is not activated until a lower threshold of current (approximately 500mA) is exceeded in the power device. When

the load current exceeds this crude threshold, the AAT4650 quiescent current increases from 15 μ A to 200 μ A. The high-speed over-current circuit works by linearly limiting the current when the current limit is reached. As the voltage begins to drop on V_{CC} due to current limiting, the current limit magnitude varies and generally decreases as the V_{CC} voltage drops to 0V.

Switching V_{CC} Voltage

The AAT4650 meets PC card standards for switching the V_{CC} output by providing a ground path for V_{CC} , as well as a high impedance state. The PC card protocol for determining low voltage operations is to first power the peripheral with 5V and poll for 3.3V operation. When transitioning from 5V to 3.3V, V_{CC} must be discharged to less than 0.8V to provide a hard reset. The resistive ground state ($CTL1 = 0$, $CTL0 = 0$) will accommodate this. The ground state will also guarantee the V_{CC} voltage to be discharged within the specified amount of time (100ms).

Printed Circuit Board Layout Recommendations

For proper thermal management, to minimize PCB trace resistance, and to take advantage of the low $R_{DS(ON)}$ of the AAT4650, a few circuit board layout rules should be followed: V_{CC3} , V_{CC5} , and V_{CC} should be routed using wider than normal traces; the two V_{CC} pins (Pins 6 and 7) should be connected to the same wide PCB trace; and GND should be connected to a ground plane. For best performance, C_{IN} and C_{OUT} should be placed close to the package pins.

Timing Diagram

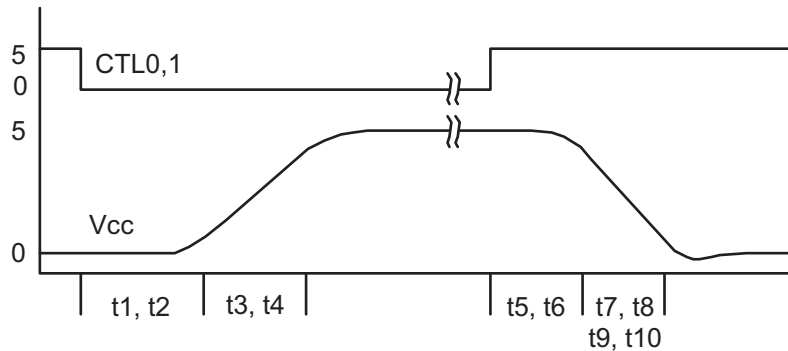
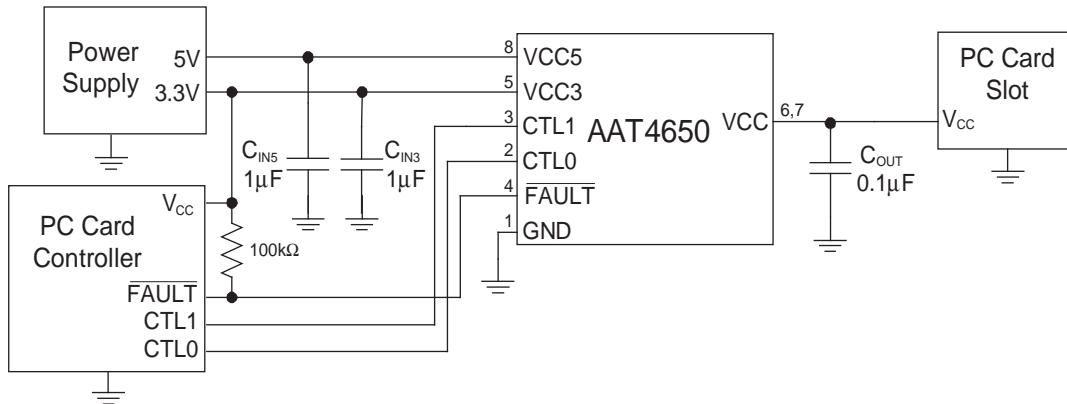

Figure 1: V_{CC} Switching Time Diagram.

Refer to V_{CC} Switching Time specifications in the Electrical Characteristics section for definitions of t1 to t10.

Typical PC Card Application Circuit



Evaluation Board Layout

The AAT4650 evaluation board layout follows the printed circuit board layout recommendations and can be used for good applications layout.

Note: Board layout shown is not to scale.

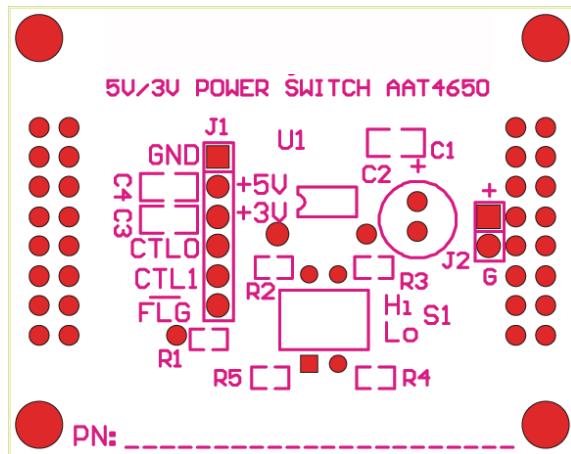

Figure 2: Evaluation Board Top Side Silk Screen Layout / Assembly Drawing.

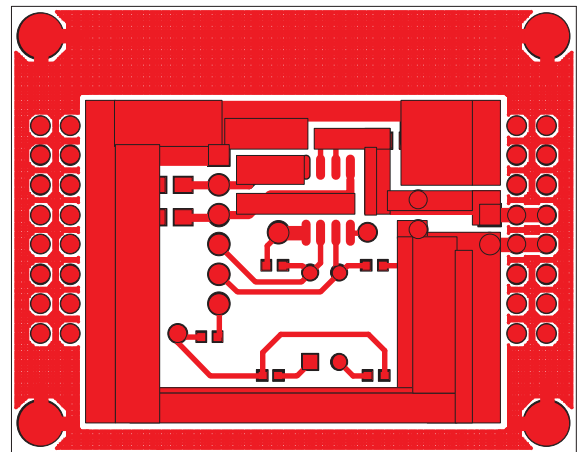

Figure 3: Evaluation Board Component Side Layout.

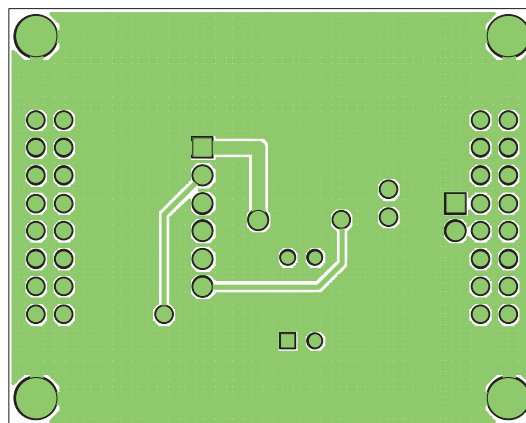

Figure 4: Evaluation Board Solder Side Layout.

Ordering Information

Package	Marking	Part Number (Tape and Reel) ¹
SOP-8	4650	AAT4650IAS-T1



Skyworks Green™ products are compliant with all applicable legislation and are halogen-free. For additional information, refer to *Skyworks Definition of Green™*, document number SQ04-0074.

Package Information

SOP-8

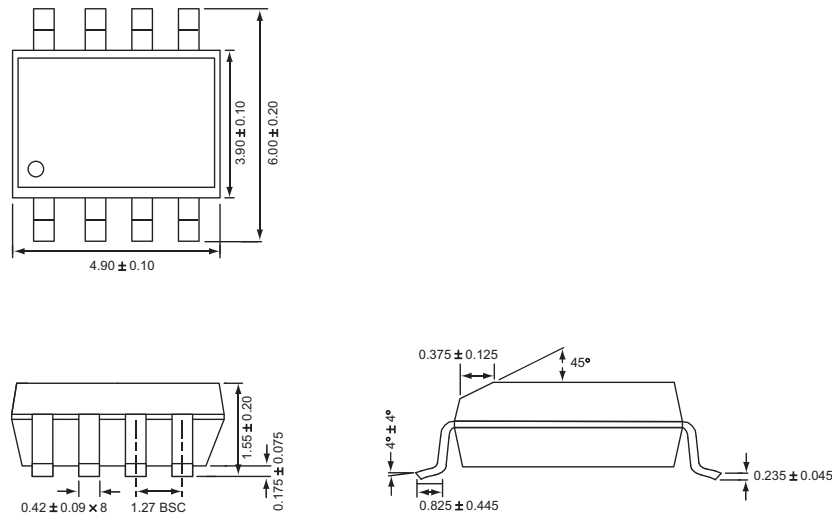

All dimensions in millimeters.

1. Sample stock is generally held on all part numbers listed in **BOLD**.

Copyright © 2012 Skyworks Solutions, Inc. All Rights Reserved.

Information in this document is provided in connection with Skyworks Solutions, Inc. ("Skyworks") products or services. These materials, including the information contained herein, are provided by Skyworks as a service to its customers and may be used for informational purposes only by the customer. Skyworks assumes no responsibility for errors or omissions in these materials or the information contained herein. Skyworks may change its documentation, products, services, specifications or product descriptions at any time, without notice. Skyworks makes no commitment to update the materials or information and shall have no responsibility whatsoever for conflicts, incompatibilities, or other difficulties arising from any future changes.

No license, whether express, implied, by estoppel or otherwise, is granted to any intellectual property rights by this document. Skyworks assumes no liability for any materials, products or information provided hereunder, including the sale, distribution, reproduction or use of Skyworks products, information or materials, except as may be provided in Skyworks Terms and Conditions of Sale.

THE MATERIALS, PRODUCTS AND INFORMATION ARE PROVIDED "AS IS" WITHOUT WARRANTY OF ANY KIND, WHETHER EXPRESS, IMPLIED, STATUTORY, OR OTHERWISE, INCLUDING FITNESS FOR A PARTICULAR PURPOSE OR USE, MERCHANTABILITY, PERFORMANCE, QUALITY OR NON-INFRINGEMENT OF ANY INTELLECTUAL PROPERTY RIGHT; ALL SUCH WARRANTIES ARE HEREBY EXPRESSLY DISCLAIMED. SKYWORKS DOES NOT WARRANT THE ACCURACY OR COMPLETENESS OF THE INFORMATION, TEXT, GRAPHICS OR OTHER ITEMS CONTAINED WITHIN THESE MATERIALS. SKYWORKS SHALL NOT BE LIABLE FOR ANY DAMAGES, INCLUDING BUT NOT LIMITED TO ANY SPECIAL, INDIRECT, INCIDENTAL, STATUTORY, OR CONSEQUENTIAL DAMAGES, INCLUDING WITHOUT LIMITATION, LOST REVENUES OR LOST PROFITS THAT MAY RESULT FROM THE USE OF THE MATERIALS OR INFORMATION, WHETHER OR NOT THE RECIPIENT OF MATERIALS HAS BEEN ADVISED OF THE POSSIBILITY OF SUCH DAMAGE.

Skyworks products are not intended for use in medical, lifesaving or life-sustaining applications, or other equipment in which the failure of the Skyworks products could lead to personal injury, death, physical or environmental damage. Skyworks customers using or selling Skyworks products for use in such applications do so at their own risk and agree to fully indemnify Skyworks for any damages resulting from such improper use or sale.

Customers are responsible for their products and applications using Skyworks products, which may deviate from published specifications as a result of design defects, errors, or operation of products outside of published parameters or design specifications. Customers should include design and operating safeguards to minimize these and other risks. Skyworks assumes no liability for applications assistance, customer product design, or damage to any equipment resulting from the use of Skyworks products outside of stated published specifications or parameters.

Skyworks, the Skyworks symbol, and "Breakthrough Simplicity" are trademarks or registered trademarks of Skyworks Solutions, Inc., in the United States and other countries. Third-party brands and names are for identification purposes only, and are the property of their respective owners. Additional information, including relevant terms and conditions, posted at www.skyworksinc.com, are incorporated by reference.