

Absolute encoders - SSI

End shaft max. $\varnothing 14$ mm

Optical multiturn encoders 14 bit ST / 12 bit MT

GXM2S - SSI



GXM2S with end shaft

Features

- Encoder multiturn / SSI
- Optical sensing
- Resolution: singleturn 14 bit, multiturn 12 bit
- End shaft $\varnothing 12$ mm / $\varnothing 14$ mm
- Electronic setting of zero point
- Permanent check of code continuity
- Counting direction input
- Suitable for high positive, negative accelerations
- Available with additional incremental output

Technical data - electrical ratings

Voltage supply	10...30 VDC
Reverse polarity protection	Yes
Consumption w/o load	≤ 50 mA (24 VDC)
Initializing time (typ.)	20 ms after power on
Interfaces	SSI, Incremental A 90° B (optional)
Function	Multiturn
Steps per turn	≤ 16384 / 14 bit
Number of turns	4096 / 12 bit
Incremental output	2048 pulses A90°B + inverted
Absolute accuracy	$\pm 0.025^\circ$
Sensing method	Optical
Code	Gray or binary
Code sequence	CW/CCW coded by connection
Inputs	SSI clock Control signals UP/DOWN and zero
Output circuit	SSI data: linedriver RS485 Diagnostic and incremental outputs
Interference immunity	DIN EN 61000-6-2
Emitted interference	DIN EN 61000-6-4
Diagnostic functions	Self-diagnosis Code continuity check Multiturn sensing
Approval	UL approval / E63076

Technical data - mechanical design

Dimensions (flange)	$\varnothing 58$ mm
Shaft	$\varnothing 12$ mm end shaft $\varnothing 14$ mm end shaft
Protection DIN EN 60529	IP 54
Operating speed	≤ 6000 rpm (mechanical) ≤ 6000 rpm (electric)
Starting torque	≤ 0.015 Nm (IP 54)
Rotor moment of inertia	20 gcm ²
Materials	Housing: steel Flange: steel
Operating temperature	-25...+85 °C -40...+85 °C (optional)
Relative humidity	95 % non-condensing
Resistance	DIN EN 60068-2-6 Vibration 10 g, 16-2000 Hz DIN EN 60068-2-27 Shock 100 g, 6 ms
Weight approx.	600 g
Connection	Connector M23, 12-pin

Absolute encoders - SSI

End shaft max. $\varnothing 14$ mm

Optical multiturn encoders 14 bit ST / 12 bit MT

GXM2S - SSI

Part number

Multiturn

GXM2S.

Pulses / Incremental output

- 02 No incremental output
- 04 2048 pulses / push-pull
- 06 2048 pulses / RS422
- 07 2048 periods / Sin/Cos
- 27 1024 periods / Sin/Cos

Connection

- A1 Connector M23, 12-pin, radial
- A3 Connector M23, 12-pin, radial, for incremental output 04/06/07

Voltage supply / signals

- 10 10...30 VDC / gray code 25 bit
- 11 5 VDC / gray code 25 bit
- 12 10...30 VDC / binary code 25 bit
- 13 5 VDC / binary code 25 bit
- 20 10...30 VDC / gray code 24 bit
- 24 10...30 VDC / binary code 24 bit
- 90 10...30 VDC / gray code 26 bit
- 92 10...30 VDC / binary code 26 bit

End shaft

- 0 End shaft $\varnothing 12$ mm without pin
- 1 End shaft $\varnothing 12$ mm with pin 15 mm
- B End shaft $\varnothing 12$ mm with pin 9.5 mm
- 4 End shaft $\varnothing 14$ mm without pin
- 5 End shaft $\varnothing 14$ mm with pin 15 mm
- F End shaft $\varnothing 14$ mm with pin 9.5 mm

Accessories

Connectors and cables

Z 130.001	Female connector M23, 12-pin, less cable
Z 130.003	Female connector M23, 12-pin, 2 m cable
Z 130.005	Female connector M23, 12-pin, 5 m cable
Z 130.007	Female connector M23, 12-pin, 10 m cable
Z 182.001	Female connector M23, 12-pin, less cable (incr.)
Z 182.003	Female connector M23, 12-pin, 2 m (incr.)
Z 182.005	Female connector M23, 12-pin, 5 m (incr.)

Mounting accessories

Z 119.023	Spring coupling for encoders with $\varnothing 58$ mm housing
Z 119.024	Torque support and spring washer for encoders with 9.5 mm pin
Z 119.041	Torque support by rubber buffer element for encoders with 15 mm pin
Z 119.050	Spring coupling
Z 119.053	Spring coupling height 19.1 mm
Z 119.072	Spring coupling for encoders with $\varnothing 58$ mm housing, hole distance 73 mm
Z 119.073	Spring coupling for encoders with $\varnothing 58$ mm housing, hole distance 68 mm
Z 119.076	Spring coupling for encoders with $\varnothing 58$ mm housing
Z 119.082	Spring coupling for encoders with $\varnothing 58$ mm housing, hole distance 63 mm

Data transfer

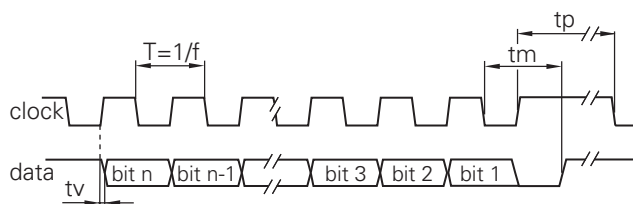

Clock frequency f	62.5...1500 kHz
Scan ratio of T	40...60 %
Time lag tv	150 ns
Monoflop time tm	25 μ s + T/2
Clock interval tp	30 μ s

Absolute encoders - SSI

End shaft max. $\varnothing 14$ mm

Optical multiturn encoders 14 bit ST / 12 bit MT

GXM2S - SSI

Terminal significance	
UB	Encoder voltage supply.
GND	Encoder ground connection relating to UB.
Data+	Positive, serial data output of differential linedriver.
Data-	Negative, serial data output of differential linedriver.
Clock+	Positive SSI clock input. Clock+ together with clock- forms a current loop. A current of approx. 7 mA towards clock+ input means logic 1 in positive logic.
Clock-	Negative SSI clock input. Clock- together with clock+ forms a current loop. A current of approx. 7 mA towards clock- input means logic 0 in positive logic.
Zero setting	Input for setting a zero point anywhere within the programmed encoder resolution. The zero setting operation is triggered by a High impulse and has to be in line with the selected direction of rotation (UP/DOWN). Connect to GND after setting operation for maximum interference immunity. Impulse duration ≥ 100 ms.
$\overline{\text{DATAVALID}}$	Diagnostic output. An error warning is given at level Low. Important: Interferences must be drained by the downstream electronics.
$\overline{\text{DATAVALID MT}}$	Diagnostic output for monitoring the multiturn sensor voltage supply. Upon dropping below a defined voltage level the $\overline{\text{DV MT}}$ output is switched to Low.
$\overline{\text{UP/DOWN}}$	$\overline{\text{UP/DOWN}}$ counting direction input. This input is standard on High. $\overline{\text{UP/DOWN}}$ means ascending output data with clockwise shaft rotation when looking at flange. $\overline{\text{UP/DOWN-Low}}$ means ascending values with counterclockwise shaft rotation when looking at flange.
Incremental Outputs	Incremental tracks A 90° B and inverted.

Terminal assignment		
GXM2S		
Connector	Core colour	Assignment
Pin 1	brown	UB
Pin 2	black	GND
Pin 3	blue	Clock+
Pin 4	beige	Data+
Pin 5	green	Zero setting
Pin 6	yellow	Data-
Pin 7	violet	Clock-
Pin 8	brown/yellow	$\overline{\text{DATAVALID}}$
Pin 9	pink	$\overline{\text{UP/DOWN}}$
Pin 10	black/yellow	$\overline{\text{DATAVALID MT}}$
Pin 11 - 12	-	-

GXM2S with incremental tracks sine/cosine			
Connector	Core colour	Assignment	
		Incremental	Sine/cosine
Pin 1	brown	UB	UB
Pin 2	white	GND	GND
Pin 3	blue	Clock+	Clock+
Pin 4	green	Data+	Data+
Pin 5	grey	Zero setting	Zero setting
Pin 6	yellow	Data-	Data-
Pin 7	red	Clock-	Clock-
Pin 8	red/blue	Track B inv.	$\overline{\text{Cosine}}$
Pin 9	pink	$\overline{\text{UP/DOWN}}$	$\overline{\text{UP/DOWN}}$
Pin 10	violet	Track A inv.	$\overline{\text{Sine}}$
Pin 11	black	Track A	Sine
Pin 12	grey/pink	Track B	Cosine

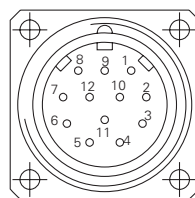

Please use cores twisted in pairs (for example clock+ / clock-) for extension cables of more than 10 m length.

Absolute encoders - SSI

End shaft max. $\varnothing 14$ mm

Optical multiturn encoders 14 bit ST / 12 bit MT

GXM2S - SSI

Trigger level

SSI	Circuit	Incremental outputs	Linedriver RS422
SSI-Clock	Optocoupler	Output level High	>2.5 V (I = -20 mA)
SSI-Data	Linedriver RS485	Output level Low	<0.5 V (I = 20 mA)
		Load High / Low	<20 mA
Control inputs	Input circuit	Outputs	Sine / Cosine
Input level High	>0.7 UB	Output level	1 Vpp ± 10 %
Input level Low	<0.3 UB	Load	<10 mA
Input resistance	10 k Ω		
Diagnostic outputs or Incremental outputs	Output circuit Push-pull circuit-proof		
Output level High	>UB -3.5 V (I = -20 mA)		
Output level Low	<0.5 V (I = 20 mA)		
Load High / Low	<20 mA		

Dimensions

GXM2S

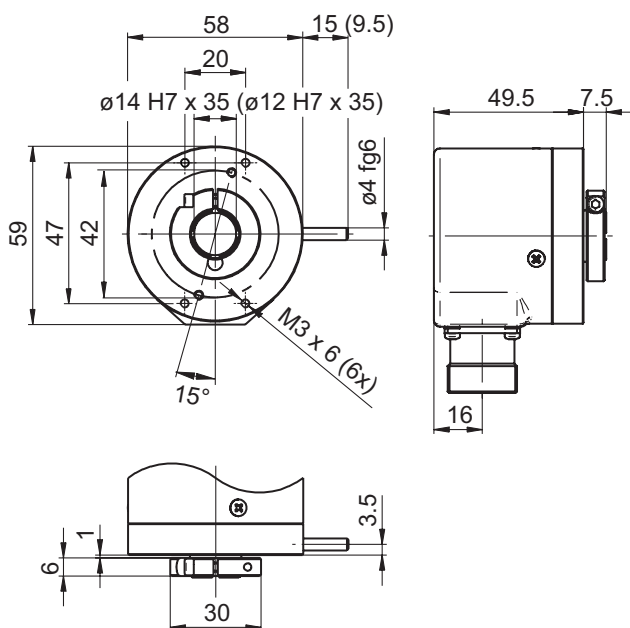

Connector dimensions

