

Absolute encoders - SSI

End shaft $\varnothing 12$ mm

Magnetic single- or multiturn encoders 12 bit ST / 13 bit MT

BMSH 58, BMMH 58 SSI - MAGRES



BMMH 58 SSI with end shaft

Features

- Encoder single- or multiturn / SSI
- Magnetic sensing
- Resolution: singleturn 12 bit, multiturn 13 bit
- High resistance to shock and vibrations
- Reset input

Technical data - electrical ratings

Voltage supply	5 VDC ± 10 % 10...30 VDC
Consumption w/o load (typ.)	100 mA (5 VDC) 50 mA (24 VDC)
Initializing time (typ.)	170 ms after power on
Interface	SSI
Steps per turn	4096 / 12 bit
Absolute accuracy	$\pm 1^\circ$
Sensing method	Magnetic
Code	Gray or binary
Code sequence	CW: ascending values with clockwise sense of rotation (looking at flange)
Inputs	SSI clock Reset input
Output circuit	SSI data: linedriver RS485
Interference immunity	DIN EN 61000-6-2
Emitted interference	DIN EN 61000-6-3
Approval	UL approval / E217823

BMSH 58

Function	Singleturn
----------	------------

BMMH 58

Function	Multiturn
Number of turns	8192 / 13 bit

Technical data - mechanical design

Dimensions (flange)	$\varnothing 58$ mm
Shaft	$\varnothing 12$ mm end shaft
Protection DIN EN 60529	IP 42, IP 65
Operating speed	≤ 12000 rpm (mechanical) ≤ 6000 rpm (electric)
Operating torque typ.	0.0093 Nm
Materials	Housing: steel/aluminium Flange: aluminium
Operating temperature	-20...+85 °C
Relative humidity	95 %
Resistance	DIN EN 60068-2-6 Vibration 30 g, 10-2000 Hz DIN EN 60068-2-27 Shock 500 g, 6 ms
Weight approx.	300 g
Connection	Connector M12, 8-pin Connector M23, 12-pin Cable

Absolute encoders - SSI

End shaft $\varnothing 12$ mm

Magnetic single- or multiturn encoders 12 bit ST / 13 bit MT

BMSH 58, BMMH 58 SSI - MAGRES

Part number

Singleturn

BMSH 58S1 12/00

Connection
5 Cable radial
A Connector
M23, radial
N Connector
M12, radial

Shaft
B2 End shaft $\varnothing 12$ mm,
IP 42, with clamping
ring
P2 End shaft $\varnothing 12$ mm,
IP 65, with clamping
ring

Resolution
12/00 12 bit singleturn

Voltage supply / signals
05C 5 VDC / SSI
24C 10...30 VDC / SSI

Code
G Gray code
N Binary code

Multiturn

BMMH 58S1 12/13

Connection
5 Cable radial
A Connector
M23, radial
N Connector
M12, radial

Shaft
B2 End shaft $\varnothing 12$ mm,
IP 42, with clamping
ring
P2 End shaft $\varnothing 12$ mm,
IP 65, with clamping
ring

Resolution
12/13 12/13 bit single-/multiturn

Voltage supply / signals
05C 5 VDC / SSI
24C 10...30 VDC / SSI

Code
G Gray code
N Binary code

Data transfer

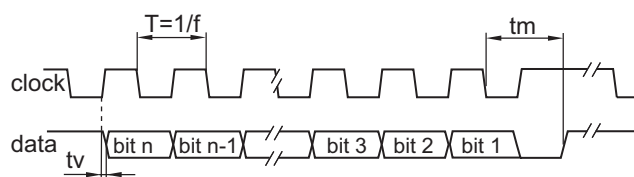

Clock frequency f	100...1000 kHz
Scan ratio of T	40...60 %
Time lag tv	200 ns
Monoflop time tm	20 μ s + T/2

Accessories

Connectors and cables

10116717	Female connector M23, 12-pin, straight
10153334	Female connector M23, 12-pin, straight, 2 m cable
10153335	Female connector M23, 12-pin, straight, 5 m cable
10146775	Female connector M12, 8-pin, straight
10127844	Female connector M12, 8-pin, straight, shielded, 2 m
10129332	Female connector M12, 8-pin, straight, shielded, 5 m cable

Mounting accessories

10136635	Set of spring coupling for encoders $\varnothing 58$ mm
10110616	Clamp set
10107540	Torque pin
10109520	Torque spring washer

Absolute encoders - SSI

End shaft $\varnothing 12$ mm

Magnetic single- or multturn encoders 12 bit ST / 13 bit MT

BMSH 58, BMMH 58 SSI - MAGRES

Terminal significance

+Vs	Encoder supply voltage.
0 V	Encoder ground connection relating to +Vs.
Data+	Positive, serial data output of differential linedriver.
Data-	Negative, serial data output of differential linedriver.
Clock+	Positive SSI clock input. Clock+ together with Clock- forms a current loop. A current of approx. 7 mA towards Clock+ input means logic 1 in positive logic.
Clock-	Negative SSI clock input. Clock- together with Clock+ forms a current loop. A current of approx. 7 mA towards Clock- input means logic 0 in positive logic.
Zero	Input for setting a zero point anywhere within the encoder resolution. The zero setting operation is triggered by a Low impulse. Connect to +Vs after setting operation for maximum interference immunity. Impulse duration >2 ms.
Rot. direction	Ascending position values when looking at the flange and rotating the shaft clockwise.

Terminal assignment

Cable / Connector M23 male
for connection references **-A** and **-5**

Connector	Core colour	Signals	Description
Pin 1	yellow	Clock-	Clock signal
Pin 2	green	Clock+	Clock signal
Pin 3	grey	Data+	Data signal
Pin 4	pink	Data-	Data signal
Pin 5	blue	Zero	Zero setting input
Pin 6	–	n.c.	–
Pin 7	–	n.c.	–
Pin 8	–	n.c.	–
Pin 9	red	d.u.	do not use
Pin 10	–	n.c.	–
Pin 11	brown	+Vs	Supply voltage
Pin 12	white	0 V	Supply voltage
Screen	connected to housing		
Cable data	8 x 0.14 mm ²		

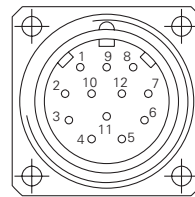

Connector M12 male

for connection reference **-N**

Connector	Signals	Description
Pin 1	0 V	Supply voltage
Pin 2	+Vs	Supply voltage
Pin 3	Clock+	Clock signal
Pin 4	Clock-	Clock signal
Pin 5	Data+	Data signal
Pin 6	Data-	Data signal
Pin 7	Zero	Zero setting input
Pin 8	d.u.	do not use

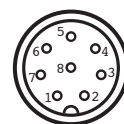

Trigger level

Control inputs	Input circuit
Input level Low	<0,4 V (>2 ms)
Input level High	+Vs or open

Absolute encoders - SSI

End shaft $\varnothing 12$ mm

Magnetic single- or multiturn encoders 12 bit ST / 13 bit MT

BMSH 58, BMMH 58 SSI - MAGRES

Dimensions

BMSH/BMMH 58 SSI cable radial

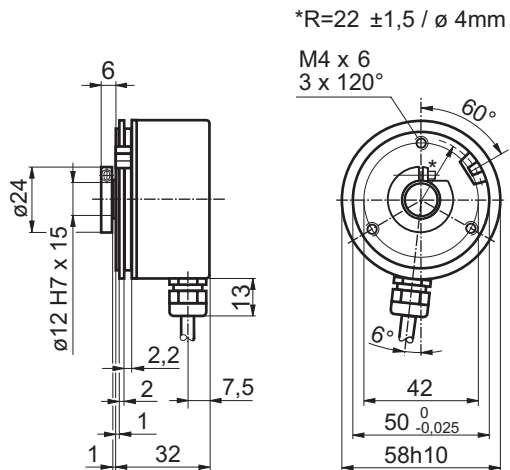

BMSH/BMMH 58 SSI connector M23 radial

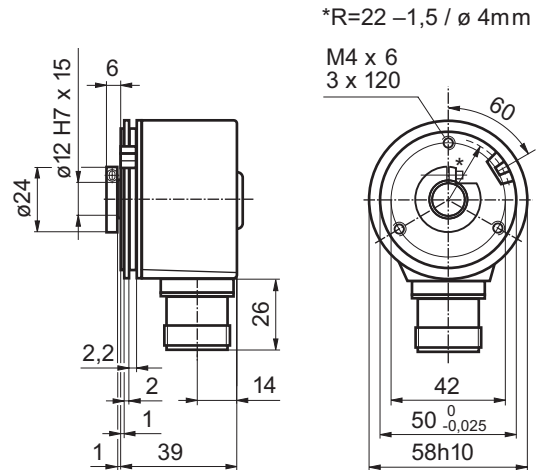

BMSH/BMMH 58 SSI connector M12 radial

