

# Absolute encoders - SSI

End shaft max.  $\varnothing 6$  mm

Magnetic single- or multiturn encoders 12 bit ST / 13 bit MT

## BMSH 30, BMMH 30 SSI - MAGRES



BMMH 30 SSI with end shaft

### Features

- Mini encoder single- or multiturn / SSI
- Magnetic sensing
- Resolution: singleturn 12 bit, multiturn 13 bit
- Housing  $\varnothing 30$  mm
- High resistance to shock and vibrations
- Reset input

### Technical data - electrical ratings

Voltage supply	5 VDC $\pm 10$ % 10...30 VDC
Consumption w/o load (typ.)	100 mA (5 VDC) 50 mA (24 VDC)
Initializing time (typ.)	70 ms after power on
Interface	SSI
Steps per turn	4096 / 12 bit
Absolute accuracy	$\pm 1^\circ$
Sensing method	Magnetic
Code	Gray or binary
Code sequence	CW: ascending values with clockwise sense of rotation (looking at flange)
Inputs	SSI clock Reset input
Output circuit	SSI data: linedriver RS485
Interference immunity	DIN EN 61000-6-2
Emitted interference	DIN EN 61000-6-3
Approval	UL approval / E217823
<b>BMSH 30</b>	
Function	Singleturn
<b>BMMH 30</b>	
Function	Multiturn
Number of turns	8192 / 13 bit

### Technical data - mechanical design

Dimensions (flange)	$\varnothing 30$ mm
Shaft	$\varnothing 4$ mm end shaft $\varnothing 6$ mm end shaft
Protection DIN EN 60529	IP 65
Operating speed	$\leq 6000$ rpm
Operating torque typ.	0.0075 Nm
Materials	Housing: steel Flange: aluminium
Operating temperature	-20...+85 $^\circ\text{C}$
Relative humidity	95 %
Resistance	DIN EN 60068-2-6 Vibration 30 g, 10-2000 Hz DIN EN 60068-2-27 Shock 100 g, 6 ms
Connection	Connector M12, 8-pin Cable 1 m
<b>BMSH 30</b>	
Weight approx.	60 g
<b>BMMH 30</b>	
Weight approx.	70 g



# Absolute encoders - SSI

End shaft max.  $\varnothing 6$  mm

Magnetic single- or multiturn encoders 12 bit ST / 13 bit MT

## BMSH 30, BMMH 30 SSI - MAGRES

Terminal significance	
+Vs	Encoder supply voltage.
0 V	Encoder ground connection relating to +Vs.
Data+	Positive, serial data output of differential linedriver.
Data-	Negative, serial data output of differential linedriver.
Clock+	Positive SSI clock input. Clock+ together with Clock- forms a current loop. A current of approx. 7 mA towards Clock+ input means logic 1 in positive logic.
Clock-	Negative SSI clock input. Clock- together with Clock+ forms a current loop. A current of approx. 7 mA towards Clock- input means logic 0 in positive logic.
Zero	Input for setting a zero point anywhere within the encoder resolution. The zero setting operation is triggered by a Low impulse. Connect to +Vs after setting operation for maximum interference immunity. Impulse duration >2 ms.
Rot. direction	Ascending position values when looking at the flange and rotating the shaft clockwise.

Terminal assignment		
<b>Cable</b> for connection references <b>-4</b> and <b>-5</b>		
Core colour	Signals	Description
brown	+Vs	Supply voltage
white	0 V	Supply voltage
grey	Data+	Data signal
pink	Data-	Data signal
green	Clock+	Clock signal
yellow	Clock-	Clock signal
blue	Zero	Zero setting input
red	d.u.	do not use
Screen	connected to housing	
Cable data	8 x 0.14 mm <sup>2</sup>	

Connector M12 male		
for connection reference <b>-N</b> and <b>-T</b>		
Connector	Signals	Description
Pin 1	0 V	Supply voltage
Pin 2	+Vs	Supply voltage
Pin 3	Clock+	Clock signal
Pin 4	Clock-	Clock signal
Pin 5	Data+	Data signal
Pin 6	Data-	Data signal
Pin 7	Zero	Zero setting input
Pin 8	d.u.	do not use



Trigger level	
Control inputs	Input circuit
Input level Low	<0,4 V (>2 ms)
Input level High	+Vs or open

# Absolute encoders - SSI

End shaft max.  $\varnothing 6$  mm

Magnetic single- or multiturn encoders 12 bit ST / 13 bit MT

## BMSH 30, BMMH 30 SSI - MAGRES

### Dimensions

BMSH 30 SSI, cable axial

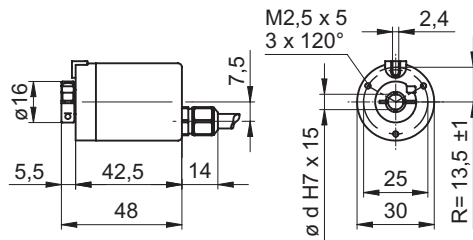

BMMH 30 SSI, cable axial

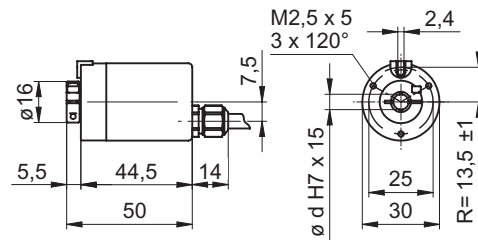

BMSH/BMMH 30 SSI, cable radial

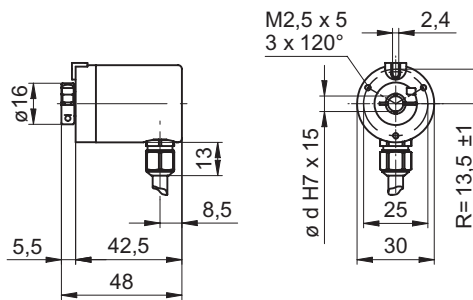

BMSH/BMMH 30 SSI, connector output axial

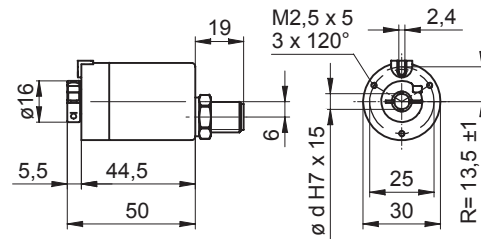

BMSH/BMMH 30 SSI, connector output radial

