



CHASSIS PLATFORMS
HA
COM
RUGGED



EMBEDDED
COMPUTING PRODUCTS



SYSTEM ACCESSORIES

BACKPLANES

COMPONENTS

PICMG: MicroTCA Products and Services

Elma Electronic

WHO IS ELMA ELECTRONIC

Founded in 1962, Elma is a leading global manufacturer and supplier of products used in integrated embedded platforms for military/aerospace, communications, medical imaging, and industrial applications. Based in Fremont, California and Wetzikon, Switzerland, the company has facilities and representatives in over 24 countries. Elma has a broad base of customers in diverse industries such as military and defense, telecommunications, industrial control, and medical electronics.

The Elma group of companies' products and services range from electromechanical components, to boards, to complete standard or custom system platforms. Elma constantly strives to provide products designed to be superior in quality, reliability, performance, and innovation. The focus is to leverage proven technology based on VITA (VME, VPX, and VXS), PICMG standard architectures (PCI, ATCA and MicroTCA) and rugged COTS based solutions.

The company offers fast, flexible response to customer needs and extensive practical knowledge in tailoring solutions to specific applications. The combined Elma Team has the knowledge and resources critical to address the increasing complexity and interplay between backplane, packaging, board level and software aspects of a successfully integrated System Solution. The addition of the ACT/Technico brand of products and services strengthens Elma's position as a vertically integrated supplier for Embedded Computing customers, while the Bustronic division provides unsurpassed high end backplane design expertise.

Elma's product line encompasses well over 16,000 parts, including system packaging and boards, enclosures, backplanes, cabinets, and other electro-mechanical components. Elma's quality level is reached through training of all employees and following of systematic procedures per ISO 9001 standards, to which Elma has been certified.

WHY CHOOSE ELMA

Flexibility | Elma tailors solutions to individual applications to ensure fast and cost-effective results.

Experience | Extensive practical experience in packaging electronic systems is used to minimize the time taken to develop new customized solutions without compromising system performance or reliability.

Compatibility | Because the two key electromechanical components - enclosures and backplanes - are made in-house, Elma guarantees compatibility, consistency and reliability.

Global Resources | With manufacturing in Europe, Asia and the USA, customers benefit from local service backed by global resources.

ELMA PRODUCT DIVISIONS

Systems



Embedded Computing Products



Backplanes



Enclosures & Components



Cabinets



Switches, Knobs & LEDs



HOW ELMA DOES IT - CORE CAPABILITIES

The company supplies a first class offering of products for standard and rugged COTS electronics packaging and sub-systems integration: boards, chassis, backplanes, mechanical components, cabinets, and LED/switches for a wide variety of applications worldwide. The ACT/Technico branded products and services enable Elma to be a leading supplier of integrated embedded boards and sub-systems built on open standards platforms, including Single Board Computers, mass storage and RAID products, I/O and networking solutions, RTOS, Linux or Windows, and device drivers.

System architecture, hardware, and software design services are offered to quickly deliver complete solutions and expedite time to market. We take true COTS products, such as single board computers and PMCs, then enhance and qualify them to meet your rugged requirements.

This extensive range of products and services gives Elma Electronic Inc. a unique ability to complete entire projects from initial system architecture through specification, design, manufacturing and test.

Elma has a professional sales team committed to the value added sale. Our sales staff and application engineers are able to match requirements to the application and recommend semi or full custom solutions when appropriate. Our staff of experienced electrical, software, mechanical and system engineers combine to provide state of the art solutions designed to meet our customers' specifications. We support those products long after shipment with warranty coverage and complete documentation packages.

In house manufacturing capability rounds out our ability to integrate the products and designs into a complete, shippable solution. Our Quality department rigorously maintains our corporate commitment to ship products that are built with quality workmanship.

Elma is capable of quickly turning projects from initial system architecture through to specification, design, manufacturing and test. We also work with you to manage the entire project including EOL issues, spares inventory and lifecycle management.

TECHNICAL CAPABILITIES

- Standard and rugged COTS integration and test expertise
- System platform architecture design and development
- Hardware and software selection
- Chassis platform design and selection
- Embedded and COTS system integration
- High performance cable assemblies
- Manufacturing
- Run rates from 10's to low 1000's
- Project management
- Full support for the project, single point of contact
- Software installation
- Bootable device drivers included as needed
- Device driver development
- Functionally tested in hardware matching target system
- Testing
- Factory test software
- System level/payload testing
SBCs, I/O, storage, operating system
- Unit level environmental testing
ESS, NEBS, MIL-STDs 167, 810, 901D
- Regulatory compliance testing CE, UL, FCC

CUSTOM SOLUTIONS

Customization is the standard at Elma Electronic. With an extensive offering of modular products as a foundation, Elma is able to leverage existing solutions and proven design concepts to meet any custom application. This approach ensures that Elma will provide a quality, compliant solution with significantly reduced lead time, cost and risk. Elma leads the industry in modifying standard PICMG based backplanes and chassis to meet customers' exact needs.

Table of Contents

MicroTCA System Chassis Platform

Overview	4
MicroTCA Order Key	6
Microslim	
1U & 3U 19" - Rackmount, HA (Horizontal)	7
BlueBox	
Desktop Development Unit, HA (Vertical)	9
Type 11M	
8U - 19" Rackmount, HA (Vertical)	11
Type 32M	
4U - Portable Tower, HA (Vertical)	13
COMSlim	
1U - 19" Rackmount, COM (Horizontal)	15
COMBlue	
Desktop, COM (Vertical)	17
Type 11M2	
5U - 19" Rackmount, RUGGED (Vertical)	19
Type 12R2	
5U - 19" Rackmount, RUGGED (Vertical)	21
ATR	
Air Transport, RUGGED	23

Embedded Computing Products

Overview	25
Storage	25
Single Board Computers / Blades	26
Networking	26
I/O Products	26
AppliPaks / Processor Brick	27
SystemPaks	27
Subsystems	28
Rugged Products	28

System Accessories

Test Extender Boards	29
Load Boards	29
Com, MCH	30
Power Modules	31
EMMC	31
Air Block Modules (Slot Bypass Board)	32

Backplanes - μ TCA

μ TCA Backplanes	33
----------------------	----

Components

μ TCA Card Guides	37
μ TCA ESD Clip	37
μ TCA Handle / Panel	38

MicroTCA System Platform, Overview



DESCRIPTION

MicroTCA (Micro Telecommunications Computing Architecture or MTCA.0) is an open system-level chassis specification developed by PICMG (PCI Manufacturers Group) for low-cost, small-form-factor utilizing AdvancedMC modules plugged directly into a backplane. MicroTCA inherits many of ATCA's advanced features, allowing it to support a fully managed, redundant system; it can also be configured into a simplified, non-redundant system with a "non-intelligent" card for low-cost applications. MicroTCA is defined to be complementary to AdvancedTCA, targeting edge and access applications, Customer Premises Equipment (CPE), and other applications where cost and size are major constraints. This includes data centers, industrial control, and medical, among other applications.

Elma Electronic Inc. is an active member of the PICMG MicroTCA subcommittee, providing technology leadership in the area of chassis platform and backplane design. Elma's MicroTCA solutions range from modular, full featured platforms to rugged MIL-STD configurations ready for harsh environment deployment. In addition, by optimizing solutions to meet application specific needs, Elma has developed a range of "cost reduced" platforms meet the expectations of the telecom and enterprise markets.

ADVANTAGES

- Complementary to ATCA
- Support applications where ATCA is not ideal
- Heavy emphasis on reduced start-up costs
- Leverage use of defined AdvancedMC Module standard
- AdvancedMC's directly connect to the backplane
- Smaller physical box size for size constrained applications
- Scalable reliability (relaxed system management complexity)
- Modular and serviceable (front-loadable, hot-swap)
- Rugged support for outside plant systems
- Universal platform (vs. proprietary design)

FEATURES

- Compliant to latest MicroTCA.0 specifications
- Modular design using tooled extrusions and card guides
- Allows various chassis configurations using standard building blocks
- Customization is faster, easier, and more cost-effective as design is built upon a proven modular platform
- Platforms can be assembled with a high degree of precision and meet tight design tolerances - modules plug in easily
- Accommodates various backplane configurations based on a combination of full-size (6HP), mid-size (4HP) and compact (3HP) modules without any impact to chassis mechanics
- Plastic card guides provide isolation between the modules and the chassis mechanics
- Extrusion approach will facilitate future ruggedization efforts of the modules' front panel

MicroTCA System Platform, Overview

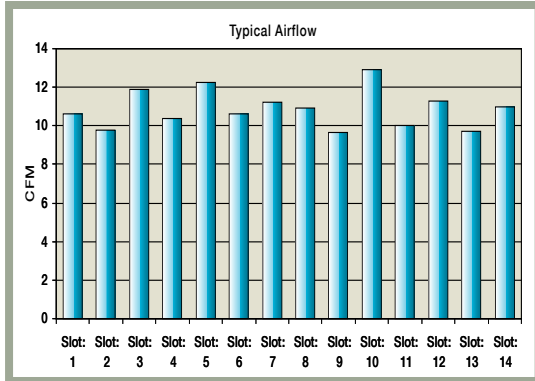

THERMAL SIMULATIONS

Elma has performed extensive thermal simulation studies to optimize the design of its comprehensive MicroTCA packaging product line. It ranges from development systems to highly redundant systems to fully populated cabinet-level solutions.

Using the Computational Fluid Dynamics (CFD) modeling software Flotherm, Elma's engineers optimize air intake and exhaust openings, increase or decrease plenum space, locate baffles to vary slot openings and redirect air flow where required. Locating hot spots in the chassis, the designer can simulate various scenarios to rectify the situation and select the appropriate fans and components. Finally, the designer finds the ideal balance of cooling, EMC, audible noise, power, and other elements to meet or exceed the specifications and keep costs low.

Reference AdvancedMC modules according to MicroTCA specification are used by the Elma team. Any custom AdvancedMC module can be incorporated in the thermal simulation to verify and optimize your specific cooling requirements.

Elma's design philosophy embraces extensive use of thermal simulations that helps to perfect the design and reduce time to market. Our Validation Lab includes thermal, environmental, and EMC chambers and a wind tunnel to verify the results.

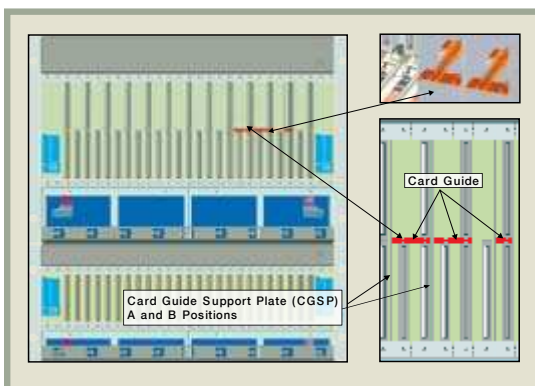
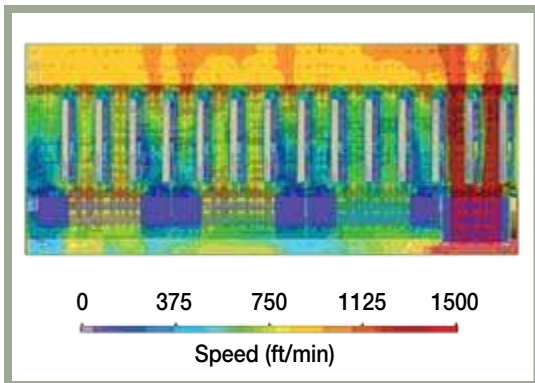

MODULAR DESIGN

Elma's unique modular MicroTCA solution allows a wide range of design options. The Elma solution is extrusion-based, with modular card guides allowing various slot counts, card heights, and component configurations. This greatly reduces the costs, lead-time, and risk of tailoring a configuration to a customer's specific needs. The card guide support plate allows the same chassis to contain both single width (75mm) or double width (150mm) modules. The Elma modular design also keeps prototyping costs low. When a project moves to higher volumes, Elma can switch from extrusions to stamped sheet metal.

MicroTCA Order Key

[11M, 11M2, 32M, 39M, 12R2, ATR] 

NUMBER OF AMC SLOTS

Example: 01 = 1, 10 = 10

MODULE SIZE

S = Single Module
D = Double Module
Z = Combination
X = Not Installed

MODULE SIZE (PITCH)

3 = Compact (3HP)
4 = Mid-Size (4HP)
6 = Full-Size (6HP)
Z = Combination

FABRIC TOPOLOGY

H = Mesh
J = Redundant Mesh
K = Single Star
L = Dual Star
N = Non Redundant
X = Not installed
Z = Custom

HEIGHT

1 = 1U
2 = 2.5U
3 = 3U
4 = 4U
5 = 5U
6 = 6U
7 = 7U
8 = 8U

WIDTH

3 = 36T
6 = 63T
4 = 42T
7 = 87T
8 = 84 T
E = ETSI

DEPTH

2 = 200 - 299mm
3 = 300 - 399mm

MODULE ORIENTATION

V = Vertical (Default Std)
H = Horizontal or custom

PSU INPUT

C = 90 - 230VAC (Fixed)
G = 90 - 230VAC (Plug in)
H = 48VDC (Plug-in)
K = 48VDC (Fixed)
M = Dual 48VDC (2 x HS, N+1)
P = 90 - 230VAC (2 x HS, N+1)
X = No PSU
Y = 24V Plug in
Z = Dual 24V Plug in

PSU OUTPUT

(NOT ALL PSU COMBINATIONS AVAILABLE)

2 = 200 - 299 watts
3 = 300 - 399 watts
4 = 400 - 499 watts
5 = 500 - 599 watts
X = Not Installed

MCH

S = 1 x plugin
D = 2 x plugin
X = Not Installed

JSM

Y = Installed
X = Not Installed

COOLING

P = PUSH Cooling
R = Redundant Push-Pull
X = Not Installed

* Note 1: 1x MCH supports 12 AMC slots

** Note 2: All slot counts are based on total number of available AMC slots (single, double or single stacked).

MicroSlim, MicroTCA, Chassis Platform

1U & 3U - 19" /Rackmount, HA, Horizontal



FEATURES:

- 19" rack mount, fully compliant to MicroTCA.0 Spec. Rev 1.0
- High availability, managed platform, with plug removable FRUs
- Low Profile 1U and 3U configurations (optimized module density)
- Holds 6 or 12 AMC's
- Star and dual star backplane topology options
- Accepts MicroTCA compliant, plug in MCH
- 2, hot swap, fully IPMI managed cooling units
- Plug removable, fully IPMI managed Power Modules (PMs)
- AC or DC input power options
- Mid or Full sized modules accepted

SCOPE OF SUPPLY

High quality 19" rack mount chassis platform compliant to the Micro TCA.0 Rev 1.0 specification consisting of; black powder coated sheet steel enclosure, high performance PICMG system backplane, power supply, cooling system and AC/DC power components. Assembled, wired and tested prior to shipment.

ORDERING INFORMATION



Description	Order Number
<ul style="list-style-type: none"> ■ 1U H x 482.6mm W x 210mm D ■ Holds 6 AMCs (single, mid-sized) ■ Star backplane: 6 AMC, 1 JTAG, 1 MCH, 1 PM ■ 2 x Plug removable Cooling Units ■ 1 x 380 W 48VDC, power module (plug in) ■ MCH and JSM not included 	39M06S4K182HH3XXR

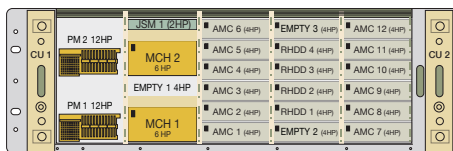

Description	Order Number
<ul style="list-style-type: none"> ■ 3U H x 482.6mm W x 210mm D ■ Holds 12 AMCs (single, mid-sized) ■ Dual Star backplane: 12 AMC, 1 JTAG, 2 MCH, 2 PM ■ 2 x Plug removable Cooling Units ■ 1 x 600 W 48VDC, power module (plug in) ■ MCH and JSM not included 	39M12S4L382HH6XXR

LINE DRAWINGS

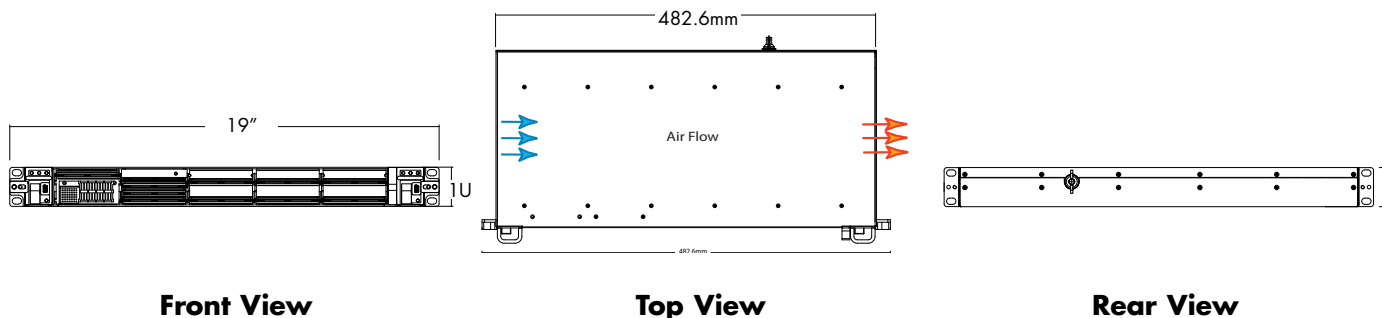

BACKPLANE MAPPING

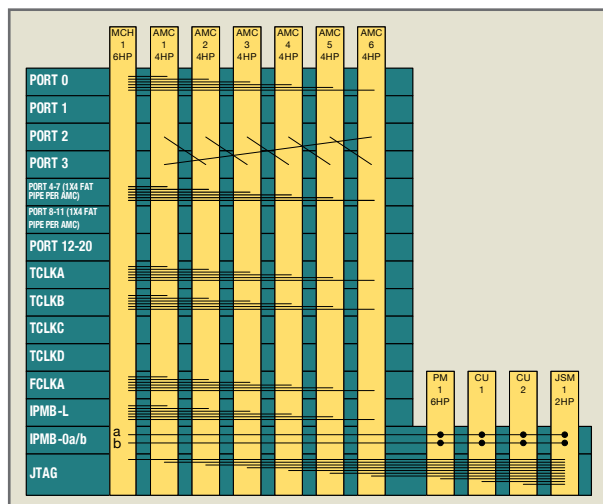

ENVIRONMENTAL

	Operating	Storage / Transit
Temperature:	0°C to +50°C	-20°C to +70°C
Altitude:	6000 ft. (1,829m)	50,000 ft. (15,240m)
Humidity:	5% to 95% Non condensing	5% to 95% Non condensing
Shock:	10 Gs @ 11ms	15 Gs @ 11ms (per ASTM 0775)
Vibration:	1.0 Gs @ 10 to 330 Hz	1.2 Gs @ 5 to 330 Hz
Agencies:	Designed to meet UL 1950, FCC Class A or B, CE	

CUSTOM CONFIGURATIONS

39M 8 2 H

NUMBER OF AMC SLOTS
Example: 01 = 1, 10 = 10

MODULE SIZE
S = Single Module
D = Double Module
Z = Combination
X = Not Installed

MODULE SIZE (PITCH)
3 = Compact (3HP)
4 = Mid-Size (4HP)
6 = Full-Size (6HP)
Z = Combination

FABRIC TOPOLOGY
K = Single Star
L = Dual Star
X = Not installed
Z = Custom

HEIGHT
1 = 1U
3 = 3U

WIDTH
8 = 84 T

DEPTH
2 = 200 - 299mm

MODULE ORIENTATION
H = Horizontal or custom

PSU INPUT
G = 90 - 230VAC (Plug in)
H = 48VDC (Plug-in)
K = 48VDC (Fixed)
M = Dual 48VDC (2xHS, N+1)
P = 90 - 230VAC(2 x HS, N+1)
X = No PSU
Y = 24V Plug in
Z = Dual 24V Plug in

PSU OUTPUT
(NOT ALL PSU COMBINATIONS AVAILABLE)
2 = 200 - 299 watts
3 = 300 - 399 watts
4 = 400 - 499 watts
5 = 500 - 599 watts
X = Not Installed

MCH
S = 1 x Plugin
D = 2 x Plugin
X = Not Installed

JSM
Y = Installed
X = Not Installed

COOLING
P = PUSH Cooling
R = Redundant Push-Pull
X = Not Installed

* Note 1: 1x MCH supports 12 AMC slots

** Note 2: All slot counts are based on total number of available AMC slots (single, double or single stacked).

BlueBox, MicroTCA, Chassis Platform

Desktop Development Unit, Vertical



FEATURES:

- Development System Platform MicroTCA.0 Spec. Rev 1.0
- Desk top configuration (6U x 42HP x 243mm)
- Elegant case with tilt feet and carry handle
- Module card cage base configurable card guide/extrusion design
- Holds 6 single/full-size, or 3 double/full-size AMCs
- Hot swappable, PM (AC or DC input options)
- PCI-Express, Serial Rapid I/O and 1 OGBase-BX4 Switching support
- Direct connection to S-ATA / SAS
- 3 synchronization clock networks
- ELMA EMMC*, IPMI Managed Cooling Unit (see page 109)

SCOPE OF SUPPLY

High quality desktop/portable platform compliant to the Micro TCA.0 Rev 1.0 specification consisting of; blue powder coated sheet steel enclosure, high performance PICMG system backplane, power module, cooling unit and AC/DC power components. Assembled, wired and tested prior to shipment.

ORDERING INFORMATION

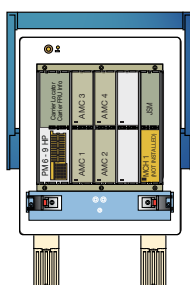
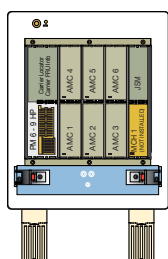

Description	Order Number
<ul style="list-style-type: none"> ■ 6U H x 42HP W x 243mm D ■ Holds 6 AMC (single/Full-sized) ■ Star backplane: 6 AMCs, 1 MCH, 1 PM, 1 CU ■ 1 x hot swap CU, bottom to top airflow ■ 1 x 400W 90-230VAC input, PM (plug in) ■ MCH not included 	39M06S6K642VG4XXP

NOTE: Handle is optional

Description	Order Number
<ul style="list-style-type: none"> ■ 6U H x 42HP W x 243mm D ■ Holds 4 AMCs (1 x double/full-sized, 4 x single/ Full-sized) ■ Star backplane: 4 AMC, 1 MCH, 1 PM, 1 CU ■ 1 x hot swap CU, bottom to top airflow ■ 1 x 400 W 48VDC, PM (plug in) ■ MCH not included 	39M04Z6K642VG4XXP

NOTE: Handle is optional

LINE DRAWINGS

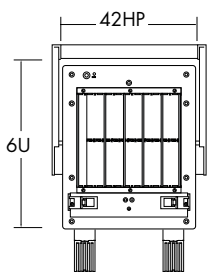

Front View

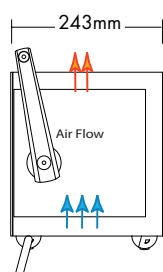

Side View

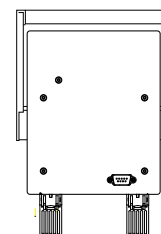

Rear View

BACKPLANE MAPPING

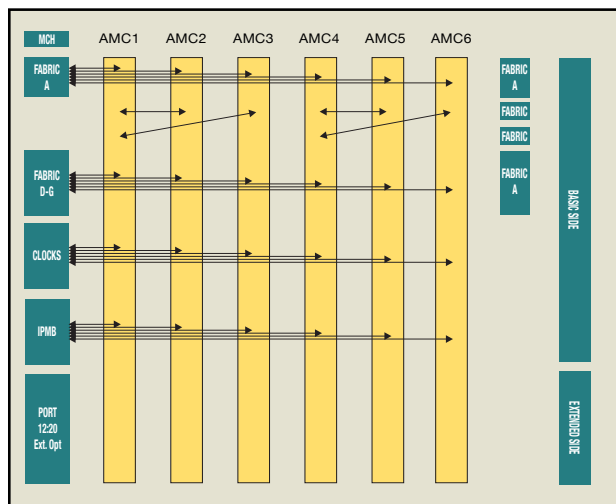

ENVIRONMENTAL

Operating	Storage / Transit
Temperature: 0°C to +50°C	-20°C to +70°C
Altitude: 6000 ft. (1,829m)	50,000 ft. (15,240m)
Humidity: 5% to 95% Non condensing	5% to 95% Non condensing
Shock: 10 Gs @ 11ms	15 Gs @ 11ms (per ASTM 0775)
Vibration: 1.0 Gs @ 10 to 330 Hz	1.2 Gs @ 5 to 330 Hz
Agencies: Designed to meet UL 1950, FCC Class A or B, CE	

CUSTOM CONFIGURATIONS

39M 6 4 2 V

NUMBER OF AMC SLOTS
Example: 01 = 1, 10 = 10

MODULE SIZE
S = Single Module
D = Double Module
Z = Combination
X = Not Installed

MODULE SIZE (PITCH)
3 = Compact (3HP)
4 = Mid-Size (4HP)
6 = Full-Size (6HP)
Z = Combination

FABRIC TOPOLOGY
K = Single Star
L = Dual Star
X = Not installed
Z = Custom

HEIGHT
6 = 6U

WIDTH
4 = 42 T

DEPTH
2 = 200 - 299mm

MODULE ORIENTATION
V = Vertical (Default Std)

PSU INPUT
G = 90 - 230VAC (Plug in)
H = 48VDC (Plug-in)
K = 48VDC (Fixed)
M = Dual 48VDC (2xHS, N+1)
P = 90 - 230VAC(2 x HS, N+1)
X = No PSU
Y = 24V Plug in
Z = Dual 24V Plug in

PSU OUTPUT
(NOT ALL PSU COMBINATIONS AVAILABLE)
2 = 200 - 299 watts
3 = 300 - 399 watts
4 = 400 - 499 watts
5 = 500 - 599 watts
X = Not Installed

MCH
S = 1 x Plugin
D = 2 x Plugin
X = Not Installed

JSM
Y = Installed
X = Not Installed

COOLING
P = PUSH Cooling
R = Redundant Push-Pull
X = Not Installed

* Note 1: 1x MCH supports 12 AMC slots

** Note 2: All slot counts are based on total number of available AMC slots (single, double or single stacked).

TYPE 11M, MicroTCA, Chassis Platform

8U - 19" Rackmount, HA, Vertical



FEATURES:

- 19" rack mount, fully compliant to MicroTCA.0 Spec. Rev 1.0
- High availability, managed platform, with plug removable FRUs
- 8U H x 84HP x 198mm D (4U, 5U and 6U options)
- Holds 14 AMC's (single, full sized)
- Modular extrusion-based solution
- Single or dual star backplanes optional
- Accepts MicroTCA compliant, plug in MCH
- 6, hot swap, fully IPMI managed cooling units
- Plug removable, fully IPMI managed Power Modules (PMs), AC or DC input power options
- Removable air filter(s)
- Customized versions available

SCOPE OF SUPPLY

High quality 19" rack mount chassis platform compliant to the Micro TCA.0 Rev 1.0 specification consisting: of pre-galvanized steel enclosure, high performance PICMG system backplane, power module, cooling units and AC/DC power components. Assembled, wired and tested prior to shipment.

ORDERING INFORMATION

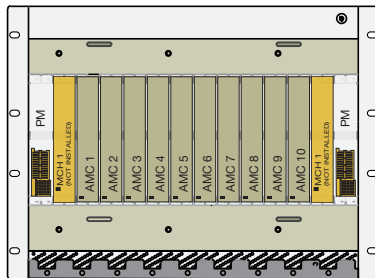

Description	Order Number
<ul style="list-style-type: none"> ■ 8U H x 84HP W x 198mm D ■ Holds 10 AMCs (double/full-sized) ■ Dual Star backplane: 10 AMC, 2 MCH, 2 PM ■ 6 x plug removable Cooling Units, push/pull ■ Single, removable air filter ■ 2 x 400W, 48VDC input PMs (Hot swap) ■ MCH not included 	11M10D6L881VM4XXR

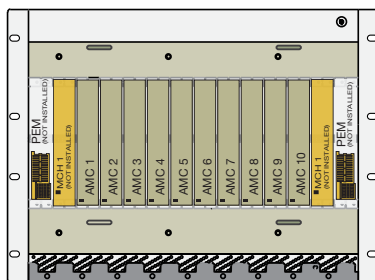

Description	Order Number
<ul style="list-style-type: none"> ■ 8U H x 84HP W x 198mm D ■ Holds 10 AMCs (double/full-sized) ■ Dual Star backplane: 10 AMC, 2 MCH, 2 PM ■ 6 x plug removable Cooling Units, push/pull ■ Single, removable air filter ■ Accepts 2 x single/full sized PEMs (not installed) ■ MCH not included 	11M10D6L881VMXXR

LINE DRAWINGS

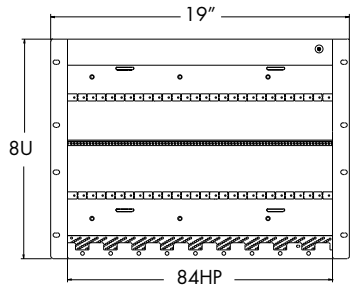

Front View

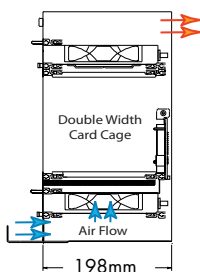

Top View

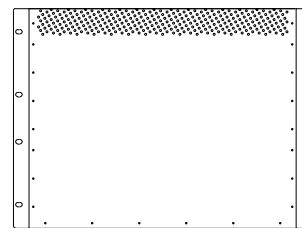

Rear View

BACKPLANE MAPPING

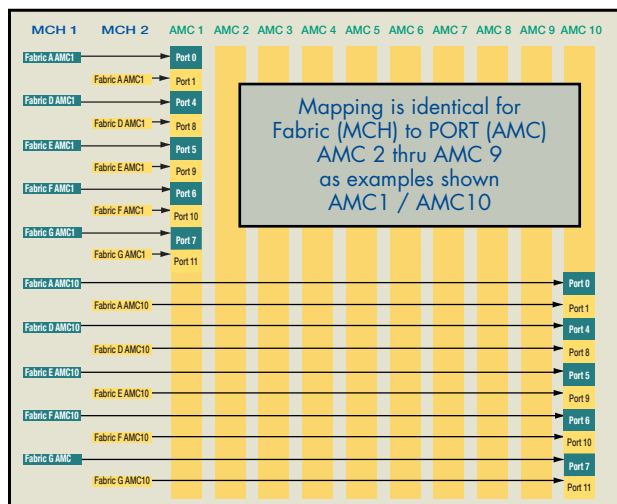

ENVIRONMENTAL

	Operating	Storage / Transit
Temperature:	0°C to +50°C	-20°C to +70°C
Altitude:	6000 ft. (1,829m)	50,000 ft. (15,240m)
Humidity:	5% to 95% Non condensing	5% to 95% Non condensing
Shock:	10 Gs @ 11ms	15 Gs @ 11ms (per ASTM 0775)
Vibration:	1.0 Gs @ 10 to 330 Hz	1.2 Gs @ 5 to 330 Hz
Agencies:	Designed to meet UL 1950, FCC Class A or B, CE	

CUSTOM CONFIGURATIONS



NUMBER OF AMC SLOTS
Example: 01 = 1, 10 = 10

MODULE SIZE
S = Single Module
D = Double Module
Z = Combination
X = Not Installed

MODULE SIZE (PITCH)
3 = Compact (3HP)
4 = Mid-Size (4HP)
6 = Full-Size (6HP)
Z = Combination

FABRIC TOPOLOGY
K = Single Star
L = Dual Star
X = Not installed
Z = Custom

HEIGHT
6 = 8U

WIDTH
8 = 84 T

DEPTH
1 = 100 - 199mm
2 = 200 - 299mm

MODULE ORIENTATION
V = Vertical (Default Std)

PSU INPUT
G = 90 - 230VAC (Plug in)
H = 48VDC (Plug-in)
K = 48VDC (Fixed)
M = Dual 48VDC (2 x HS, N + 1)
P = 90 - 230VAC (2 x HS, N + 1)
X = No PSU
Y = 24V Plug in
Z = Dual 24V Plug in

PSU OUTPUT
(NOT ALL PSU COMBINATIONS AVAILABLE)

2 = 200 - 299 watts
3 = 300 - 399 watts
4 = 400 - 499 watts
5 = 500 - 599 watts
X = Not Installed

MCH
S = 1 x Plug in
D = 2 x Plug in
X = Not Installed

JSM
Y = Installed
X = Not Installed

COOLING
P = PUSH Cooling
R = Redundant Push-Pull
X = Not Installed

* Note 1: 1x MCH supports 12 AMC slots

** Note 2: All slot counts are based on total number of available AMC slots (single, double or single stacked).

TYPE 32M, MicroTCA, Chassis Platform

4U Portable Tower, Vertical



FEATURES:

- Portable tower fully compliant to MicroTCA.0 Spec. Rev 1.0
- Ideal for prototyping & demonstrations
- High availability, managed platform, with plug removable FRUs
- Module card cage base configurable card guide/extrusion design
- Holds 6 single/full-size, or 3 double/full-size AMCs
- Hot swappable, PM (AC or DC input options)
- PCI-Express, Serial Rapid I/O and 1 OGBase-BX4 Switching support
- Direct connection to S-ATA / SAS
- 3 synchronization clock networks
- ELMA EMMC*, IPMI Managed Cooling Unit (see page 109)

SCOPE OF SUPPLY

High quality portable or desk side tower platform compliant to the Micro TCA.0 Rev 1.0 specification consisting: of vinyl clad aluminum enclosure, high performance PICMG system backplane, power module, cooling system and AC/DC power components. Assembled, wired and tested prior to shipment.

ORDERING INFORMATION

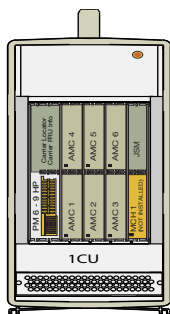

Description	Order Number
<ul style="list-style-type: none"> ■ 4U W x 63HP H x 290mm D ■ Holds 6 AMC (single/Full-sized) ■ Star backplane: 6 AMCs, 1 MCH, 1 PM, 1 CU ■ 1 x hot swap CU, bottom to top airflow ■ 1 x 400W 90-230VAC input, PM (plug in) ■ MCH not included 	32M06S6K462VG4XXP

LINE DRAWINGS

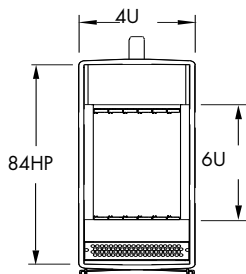

Front View

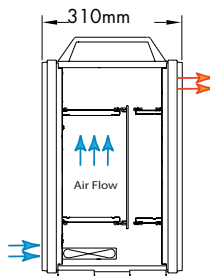

Side View

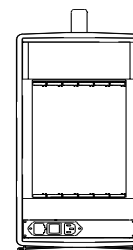

Rear View

BACKPLANE MAPPING

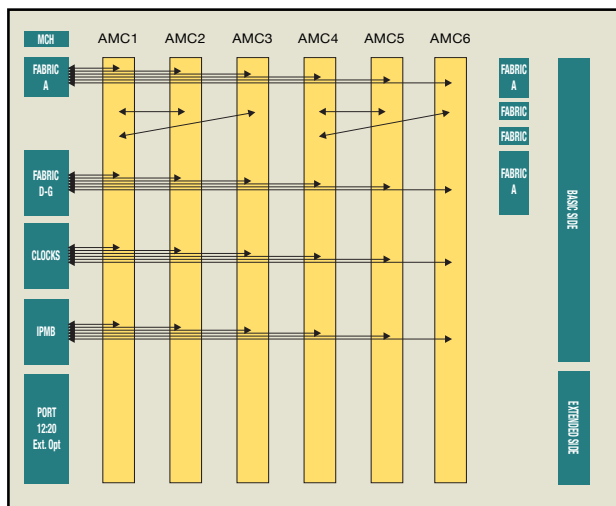

ENVIRONMENTAL

Operating	Storage / Transit
Temperature: 0°C to +50°C	-20°C to +70°C
Altitude: 6000 ft. (1,829m)	50,000 ft. (15,240m)
Humidity: 5% to 95% Non condensing	5% to 95% Non condensing
Shock: 10 Gs @ 11ms	15 Gs @ 11ms (per ASTM 0775)
Vibration: 1.0 Gs @ 10 to 330 Hz	1.2 Gs @ 5 to 330 Hz
Agencies: Designed to meet UL 1950, FCC Class A or B, CE	

CUSTOM CONFIGURATIONS

32M 4 6 2 V

NUMBER OF AMC SLOTS
Example: 01 = 1, 10 = 10

MODULE SIZE
S = Single Module
D = Double Module
Z = Combination
X = Not Installed

MODULE SIZE (PITCH)
3 = Compact (3HP)
4 = Mid-Size (4HP)
6 = Full-Size (6HP)
Z = Combination

FABRIC TOPOLOGY
K = Single Star
L = Dual Star
X = Not installed
Z = Custom

WIDTH
4 = 4U

HEIGHT
6 = 63T

DEPTH
2 = 200 - 299mm

MODULE ORIENTATION
V = Vertical (Default Std)

PSU INPUT
C = 90 - 230VAC (Fixed)
G = 90 - 230VAC (Plug in)
H = 48VDC (Plug-in)
K = 48VDC (Fixed)
M = Dual 48VDC (2x HS, N+1)
P = 90 - 230VAC (2x HS, N+1)
X = No PSU
Y = 24V Plug in
Z = Dual 24V Plug in

PSU OUTPUT
(NOT ALL PSU COMBINATIONS AVAILABLE)

2 = 200 - 299 watts
3 = 300 - 399 watts
4 = 400 - 499 watts
5 = 500 - 599 watts
X = Not Installed

MCH
S = 1 x Plugin
D = 2 x Plugin
X = Not Installed

JSM
Y = Installed
X = Not Installed

COOLING
P = PUSH Cooling
R = Redundant Push-Pull
X = Not Installed

* Note 1: 1x MCH supports 12 AMC slots

** Note 2: All slot counts are based on total number of available AMC slots (single, double or single stacked).

COMSlim, MicroTCA, Chassis Platform

1U - 19" Rackmount, Optimized, Horizontal



FEATURES:

- Cost Optimized 19" rack mount chassis platform
- Low Profile 1U, 2U and 3U configurations available
- Holds 6 - 12 AMCs
- Mid or Full sized modules accepted
- Star and dual star backplane topology options
- PSU and Cooling actively managed on Backplane
- Designed to accept feature specific MCH (will accept std. MCH)
- Push/Pull cooling configuration (fixed)
- High reliability power supply (fixed)
- AC or DC input power options

SCOPE OF SUPPLY

High quality 19" rack mount chassis platform compliant to the Micro TCA.0 Rev 1.0 specification consisting of; black powder coated sheet steel enclosure, high performance PICMG system backplane, power supply, cooling system and AC/DC power components. Assembled, wired and tested prior to shipment.

ORDERING INFORMATION



Description	Order Number
<ul style="list-style-type: none"> ■ 1U H x 449mm W x 210mm D ■ Holds 6 AMCs (single, mid-sized) ■ Star backplane: 6 AMC, 1 MCH ■ Push/Pull cooling, front to rear, 8 x fans ■ 1 x 300 W 48VDC, power supply (fixed) ■ MCH not included 	39M06S4K182HK3XXR



Description	Order Number
<ul style="list-style-type: none"> ■ 1U H x 449mm W x 210mm D ■ Holds 6 AMCs (single, mid-sized) ■ Star backplane: 6 AMC, 1 MCH ■ Push/Pull cooling, front to rear, 8 x fans ■ 1 x 300 W 48VDC, power supply (fixed) ■ Cost Optimized MCH installed 	39M06S4K182HK3SXR



MCH Description
(see page 30)

LINE DRAWINGS

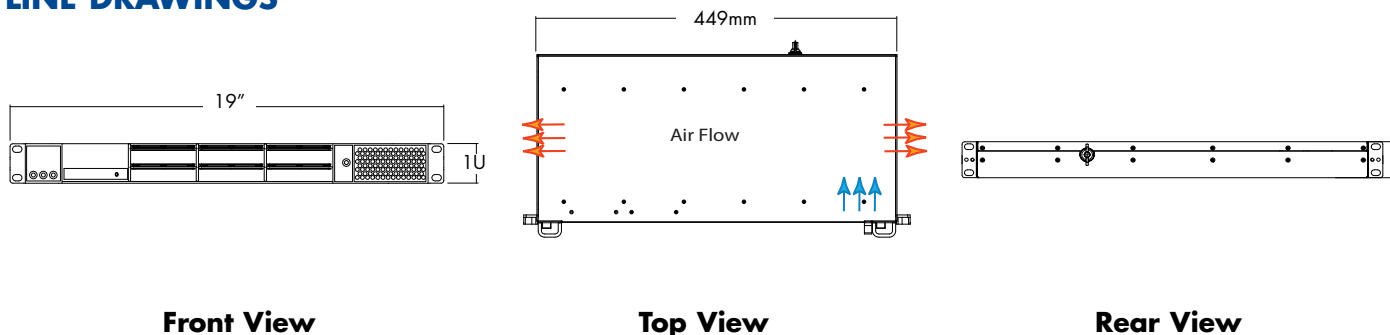

Front View

Top View

Rear View

BACKPLANE MAPPING

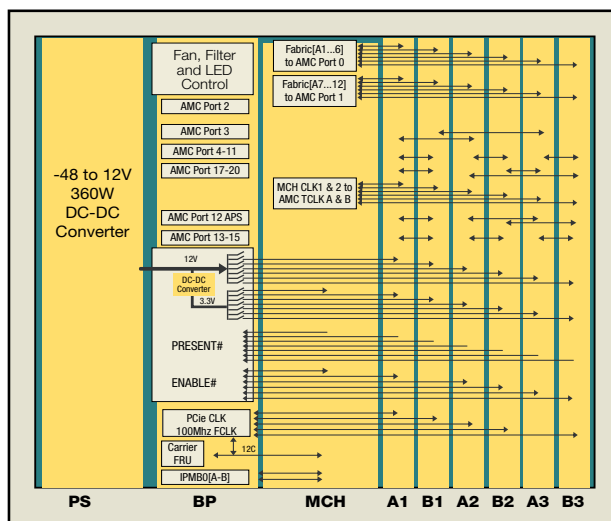

ENVIRONMENTAL

Operating	Storage / Transit
Temperature: 0°C to +50°C	-20°C to +70°C
Altitude: 6000 ft. (1,829m)	50,000 ft. (15,240m)
Humidity: 5% to 95% Non condensing	5% to 95% Non condensing
Shock: 10 Gs @ 11ms	15 Gs @ 11ms (per ASTM 0775)
Vibration: 1.0 Gs @ 10 to 330 Hz	1.2 Gs @ 5 to 330 Hz
Agencies: Designed to meet UL 1950, FCC Class A or B, CE	

CUSTOM CONFIGURATIONS

32M 1 8 2 H

NUMBER OF AMC SLOTS
Example: 01 = 1, 10 = 10

MODULE SIZE
S = Single Module
D = Double Module
Z = Combination
X = Not Installed

MODULE SIZE (PITCH)
3 = Compact (3HP)
4 = Mid-Size (4HP)
6 = Full-Size (6HP)
Z = Combination

FABRIC TOPOLOGY
K = Single Star
L = Dual Star
X = Not installed
Z = Custom

HEIGHT
1 = 1U

WIDTH
8 = 84T

DEPTH
2 = 200 - 299mm

MODULE ORIENTATION
H = Horizontal or custom

PSU INPUT
C = 90 - 230VAC (Fixed)
G = 90 - 230VAC (Plug-in)
H = 48VDC (Plug-in)
K = 48VDC (Fixed)
M = Dual 48VDC (2xHS, N+1)
P = 90 - 230VAC(2 x HS, N+1)
X = No PSU
Y = 24V Plug in
Z = Dual 24V Plug in

PSU OUTPUT
(NOT ALL PSU COMBINATIONS AVAILABLE)

2 = 200 - 299 watts
3 = 300 - 399 watts
4 = 400 - 499 watts
5 = 500 - 599 watts
X = Not Installed

MCH
S = 1 x Plugin
D = 2 x Plugin
X = Not Installed

JSM
Y = Installed
X = Not Installed

COOLING
P = PUSH Cooling
R = Redundant Push-Pull
X = Not Installed

* Note 1: 1x MCH supports 12 AMC slots

** Note 2: All slot counts are based on total number of available AMC slots (single, double or single stacked).

COMBlue, MicroTCA, Chassis Platform

Desktop, Optimized, Vertical



FEATURES:

- Cost Optimized MicroTCA development platform
- Desk top configuration (3U x 42HP x 252mm)
- Holds 5 single/full-size AMCs
- Pluggable 300W PSU, 90-230VAC input, ATX
- Bottom to top cooling
- PSU and CU, IPMI management integrated on active Backplane (Elma EMMC* (see page 109)
- Compatible with management section of MicroTCA specification
- Direct SATA / SAS connections
- Optional connection AMC1 to AMC3

SCOPE OF SUPPLY

High quality desktop/portable platform compliant to the Micro TCA.0 Rev 1.0 specification consisting of; blue powder coated sheet steel enclosure, high performance PICMG system backplane, power module, cooling unit and AC/DC power components. Assembled, wired and tested prior to shipment.

ORDERING INFORMATION

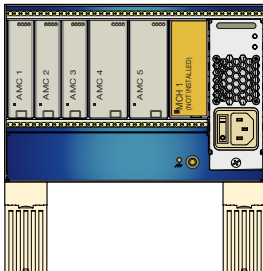

Description	Order Number
<ul style="list-style-type: none"> ■ 3U H x 42HP W x 252mm D ■ Holds 5 AMCs (3 x single/mid-sized, 2 x single/full-sized) ■ Star backplane: 5 AMC, 1 MCH, 1 PSU ■ 1 x Fan , bottom to top airflow ■ 1 x 300W, 90-230VAC input, PSU (plug in) ■ MCH not included 	<p>39M05ZZK342VG3XXP</p>

LINE DRAWINGS

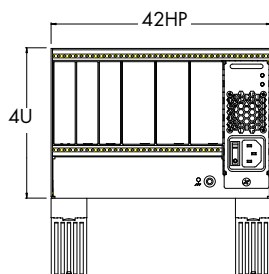

Front View

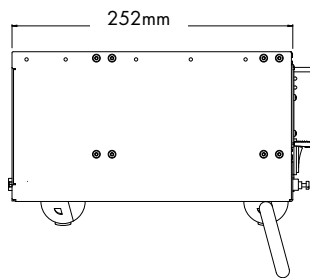

Side View

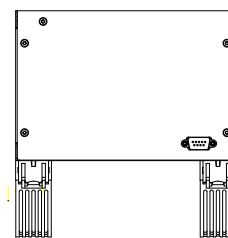

Rear View

BACKPLANE MAPPING

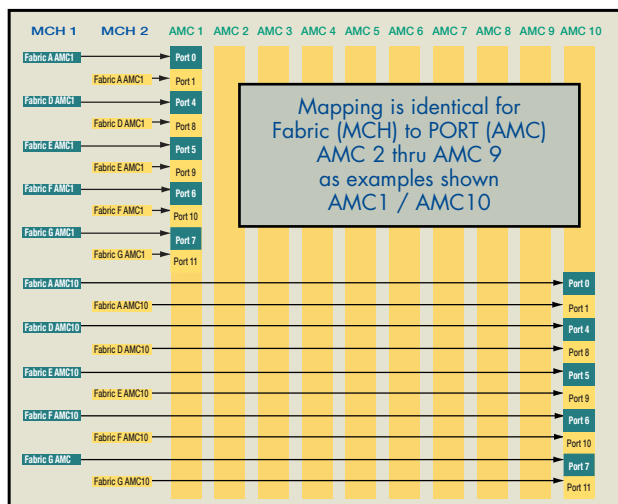

ENVIRONMENTAL

Operating	Storage / Transit
Temperature: 0°C to +50°C	-20°C to +70°C
Altitude: 6000 ft. (1,829m)	50,000 ft. (15,240m)
Humidity: 5% to 95% Non condensing	5% to 95% Non condensing
Shock: 10 Gs @ 11ms	15 Gs @ 11ms (per ASTM 0775)
Vibration: 1.0 Gs @ 10 to 330 Hz	1.2 Gs @ 5 to 330 Hz
Agencies: Designed to meet UL 1950, FCC Class A or B, CE	

CUSTOM CONFIGURATIONS

39M 3 4 2 V

NUMBER OF AMC SLOTS
Example: 01 = 1, 10 = 10

MODULE SIZE
S = Single Module
D = Double Module
Z = Combination
X = Not Installed

MODULE SIZE (PITCH)
3 = Compact (3HP)
4 = Mid-Size (4HP)
6 = Full-Size (6HP)
Z = Combination

FABRIC TOPOLOGY
K = Single Star
L = Dual Star
X = Not installed
Z = Custom

HEIGHT
3 = 3U

WIDTH
4 = 42T

DEPTH
2 = 200 - 299mm

MODULE ORIENTATION
V = Vertical (Default Std)

PSU INPUT
C = 90 - 230VAC (Fixed)
G = 90 - 230VAC (Plug in)
H = 48VDC (Plug-in)
K = 48VDC (Fixed)
M = Dual 48VDC (2 x HS, N+1)
P = 90 - 230VAC (2 x HS, N+1)
X = No PSU
Y = 24V Plug in
Z = Dual 24V Plug in

PSU OUTPUT
(NOT ALL PSU COMBINATIONS AVAILABLE)

2 = 200 - 299 watts
3 = 300 - 399 watts
4 = 400 - 499 watts
5 = 500 - 599 watts
X = Not Installed

MCH
S = 1 x Plugin
D = 2 x Plugin
X = Not Installed

JSM
Y = Installed
X = Not Installed

COOLING
P = PUSH Cooling
R = Redundant Push-Pull
X = Not Installed

* Note 1: 1x MCH supports 12 AMC slots

** Note 2: All slot counts are based on total number of available AMC slots (single, double or single stacked).

Type 11M2, MicroTCA, Chassis Platform

5U - 19" Rackmount, Rugged, Vertical



FEATURES:

- 19" rack mount, MIL compliant to PICMG® specification μ TCA.1 R1.0
- High availability, managed platform, with plug removable FRUs
- 5U H x 84HP x 198mm D (4U, 5U and 6U options)
- Holds 14 AMC's (single, full sized)
- Modular extrusion-based solution
- Single or dual star backplanes optional
- Accepts MicroTCA compliant, plug in MCH
- 3, hot swap, fully IPMI managed cooling units
- Plug removable, fully IPMI managed Power Modules (PMs), AC or DC input power options
- MIL tested Anti-vibration card guide
- Removable air filter(s)
- Customized versions available

SCOPE OF SUPPLY

High quality 19" rack mount rugged, chassis platform compliant to the PICMG® specification μ TCA.1 R1.0 specification consisting: of pre-galvanized steel enclosure, high performance PICMG system backplane, power module, cooling units and AC/DC power components. Assembled, wired and tested prior to shipment.

ORDERING INFORMATION

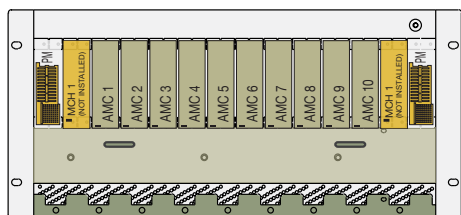

Description	Order Number
<ul style="list-style-type: none"> ■ 5U H x 84HP W x 198mm D ■ Holds 10 AMCs (double/full-sized) ■ Dual Star backplane: 10 AMC, 2 MCH, 2 PM ■ 3 x plug removable Cooling Units ■ Single, removable air filter ■ 2 x 400W, 48VDC input PMs (Hot swap) ■ MCH not included 	11M210D6L581VM4XXP

Description	Order Number
<ul style="list-style-type: none"> ■ 5U H x 84HP W x 198mm D ■ Holds 10 AMCs (double/full-sized) ■ Dual Star backplane: 10 AMC, 2 MCH, 2 PM ■ 3 x plug removable Cooling Units ■ Single, removable air filter ■ Accepts 2 x single/full sized PEMs (not installed) ■ MCH not included 	11M210D6L581VMXXXXP

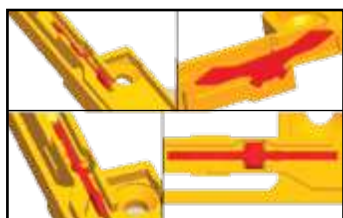

Anti-vibration Card Guide
(see page 37)

LINE DRAWINGS

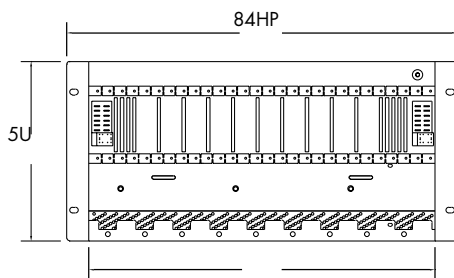

Front View

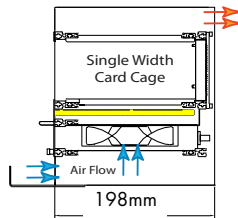

Top View

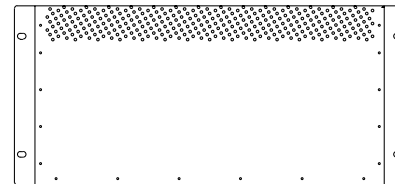

Rear View

BACKPLANE MAPPING

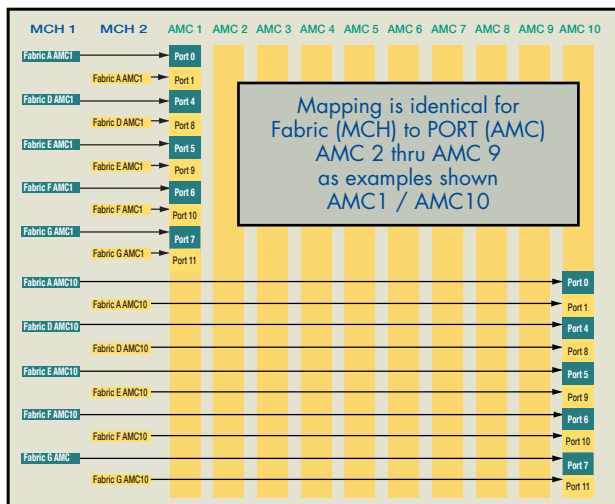

ENVIRONMENTAL

Operating	Storage / Transit
Temperature: 0°C to +50°C	-20°C to +70°C
Altitude: 6000 ft. (1,829m)	50,000 ft. (15,240m)
Humidity: 5% to 95% Non condensing	5% to 95% Non condensing
Shock: 10 Gs @ 11ms	15 Gs @ 11ms (per ASTM 0775)
Vibration: 1.0 Gs @ 10 to 330 Hz	1.2 Gs @ 5 to 330 Hz
Agencies: Designed to meet UL 1950, FCC Class A or B, CE	

CUSTOM CONFIGURATIONS

1 1M2 5 8 1 V

NUMBER OF AMC SLOTS
Example: 01 = 1, 10 = 10

MODULE SIZE
S = Single Module
D = Double Module
Z = Combination
X = Not Installed

MODULE SIZE (PITCH)
3 = Compact (3HP)
4 = Mid-Size (4HP)
6 = Full-Size (6HP)
Z = Combination

FABRIC TOPOLOGY
K = Single Star
L = Dual Star
X = Not installed
Z = Custom

HEIGHT
5 = 5U

WIDTH
8 = 84T

DEPTH
1 = 100 - 199mm
2 = 200 - 299mm

MODULE ORIENTATION
V = Vertical (Default Std)

PSU INPUT
C = 90 - 230VAC (Fixed)
G = 90 - 230VAC (Plug in)
H = 48VDC (Plug-in)
K = 48VDC (Fixed)
M = Dual 48VDC (2xHS, N+1)
P = 90 - 230VAC(2 x HS, N+1)
X = No PSU
Y = 24V Plug in
Z = Dual 24V Plug in

PSU OUTPUT
(NOT ALL PSU COMBINATIONS AVAILABLE)

2 = 200 - 299 watts
3 = 300 - 399 watts
4 = 400 - 499 watts
5 = 500 - 599 watts
X = Not Installed

MCH
S = 1 x Plugin
D = 2 x Plugin
X = Not Installed

JSM
Y = Installed
X = Not Installed

COOLING
P = PUSH Cooling
R = Redundant Push-Pull
X = Not Installed

* Note 1: 1x MCH supports 12 AMC slots

** Note 2: All slot counts are based on total number of available AMC slots (single, double or single stacked).

Type 12R2, MicroTCA, Chassis Platform

5U - 19" Rackmount, Rugged, Vertical



FEATURES:

- Ruggedized MicroTCA COTS System Platform
- PICMG® specification μ TCA.1 R1.0
- 19" rackmount, horizontal mount
- Meets MIL-STD-810F, 167, 461D, and 901D
- Shock isolated card cage and device mounting
- Rugged chassis shells from thick aluminum sheets, extrusions, and die-castings. Joined by riveting, spot-welding.
- Front to rear evacuative cooling
- Removable fan tray with LEDs for: voltage monitoring, fan fail and over temp
- Line filter, GND stud, shielded relay, IO panel, USB port, and fuse holder
- Temp: 0 C to 65 C operating temperature, Shock: 25Gs 11 ms

SCOPE OF SUPPLY

The 12R2 is designed to meet the harsh environment of shipboard, airborne, and ground mobile applications per MIL-STD's. The low profile makes it ideal when space is a premium. Highly configurable, the unit can be ordered with choice of high performance MicroTCA backplane, fixed or shock isolated card cage, AC or DC input power supply, custom I/O patch panel. Airflow is front to rear utilizing high volume fans. Shock isolated versions are designed to attenuate 25G shock inputs to the chassis to less than 10Gs at the card cage. All components, material and design concepts are chosen to meet the applicable MIL-STD environments. The units come completely assembled and wired.

ORDERING INFORMATION

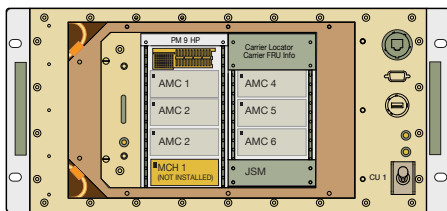

Description	Order Number
<ul style="list-style-type: none"> ■ 5U H x 84HP W x 559mm D ■ Holds 6 AMC (single/Full-sized), shock isolated card cage ■ Star backplane: 6 AMCs, 1 MCH, 1 PM, 1 CU ■ 1 x hot swap CU, bottom to top airflow ■ 1 x 600W 48VDC input, PSU (Fixed) ■ MCH not included 	12R206S6K585HK6XXXP

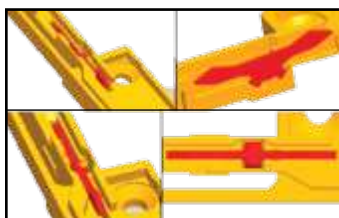

Anti-vibration Card Guide
(see page 37)

LINE DRAWINGS

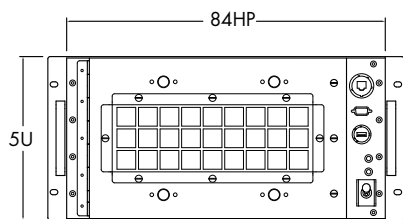

Front View

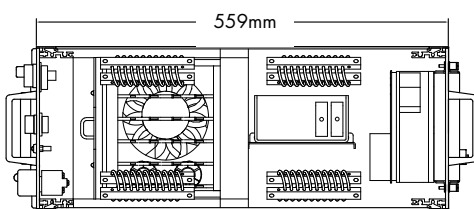

Side View

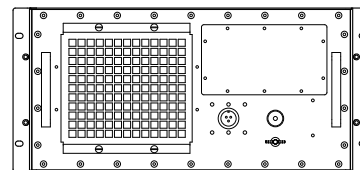

Rear View

BACKPLANE MAPPING

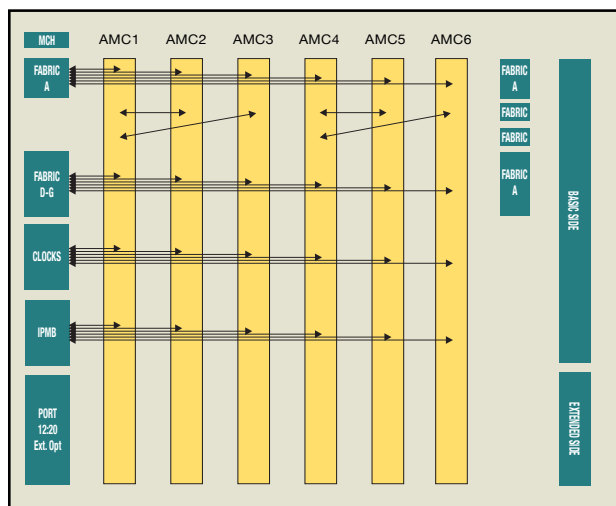

ENVIRONMENTAL

	Operating	Storage / Transit
Temperature:	0°C to +65°C	-20°C to +85°C
Altitude:	-1,200 to 18,000 ft.	50,000 ft. (15,240m)
Humidity:	0% to 95% Non condensing	0% to 95% Non condensing
Shock:	25 Gs @ 11ms	25 Gs @ 11ms (per ASTM 0775)
Vibration:	4.0 Gs RMS 15 to 2000 Hz	4.0 Gs @ 5 to 2000 Hz
Agencies:	Designed to meet UL 1950, FCC Class A or B, CE	

CUSTOM CONFIGURATIONS

12R2 5 8 5 H

NUMBER OF AMC SLOTS
Example: 01 = 1, 10 = 10

MODULE SIZE
S = Single Module
D = Double Module
Z = Combination
X = Not Installed

MODULE SIZE (PITCH)
3 = Compact (3HP)
4 = Mid-Size (4HP)
6 = Full-Size (6HP)
Z = Combination

FABRIC TOPOLOGY
K = Single Star
L = Dual Star
X = Not installed
Z = Custom

HEIGHT
5 = 5U

WIDTH
8 = 84T

DEPTH
5 = 500 - 599mm

MODULE ORIENTATION
H = Horizontal or custom

PSU INPUT
C = 90 - 230VAC (Fixed)
G = 90 - 230VAC (Plug in)
H = 48VDC (Plug-in)
K = 48VDC (Fixed)
M = Dual 48VDC (2 x HS, N+1)
P = 90 - 230VAC (2 x HS, N+1)
X = No PSU
Y = 24V Plug in
Z = Dual 24V Plug in

PSU OUTPUT
(NOT ALL PSU COMBINATIONS AVAILABLE)
2 = 200 - 299 watts
3 = 300 - 399 watts
4 = 400 - 499 watts
5 = 500 - 599 watts
6 = 600 - 699 watts
X = Not Installed

MCH
S = 1 x Plug-in
D = 2 x Plug-in
X = Not Installed

JSM
Y = Installed
X = Not Installed

COOLING
P = PUSH Cooling
R = Redundant Push-Pull
X = Not Installed

ATR, MicroTCA, Chassis Platform

ATR - Air Transport, Rugged



FEATURES:

- COTS, convection cooled 1/2, 3/4, 1, or 1 1/2 ATR per ARINC 404A
- PICMG® specification µTCA.1 R1.0
- IEEE 1101.10 Compliant
- Full range of isolated military power supplies from 150 to 750 watts
- Conduction cooled versions available
- cPCI, µTCA or custom bus formats
- Modular design allows for customization with minimum cost/lead time
- Advanced airflow distribution through card cage

SCOPE OF SUPPLY

The all-aluminum ATRs are made from punched and formed sheet metal and milled plates. A removable front panel allows I/O customization to exact application requirements and increased configurability. The ATR enclosures use electrostatic dust filters, honeycomb EMI filters and a narrow screw spacing to seal off every external seam to ensure compliance to MIL-STD-461D. The rugged designs meet the requirement for shock, vibration and structural integrity per MIL-STD-810F, MIL-STD-167 and MIL-STD-901D.

ORDERING INFORMATION

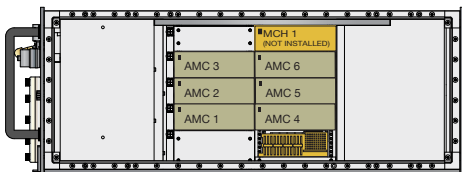

Description	Order Number
<ul style="list-style-type: none"> ■ 3/4 ATR ■ Holds 6 AMC (single/Full-sized) ■ Star backplane: 6 AMCs, 1 MCH, 1 PM, 1 CU ■ 1 x hot swap CU, bottom to top airflow ■ 1 x 400W 90-230VAC input, PM (plug in) ■ MCH not included 	<p>ATRO6S6KTBLVG4XXP</p>

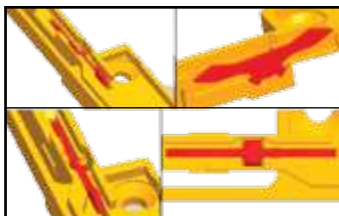

Anti-vibration Card Guide
(see page 37)

LINE DRAWINGS

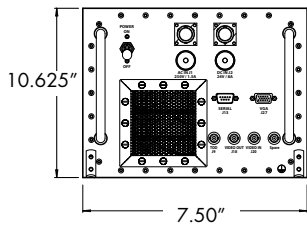

Front View

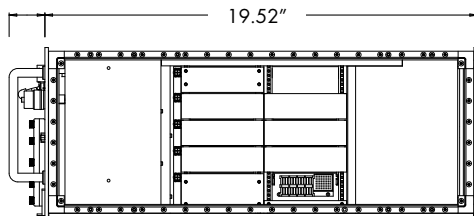

Side View

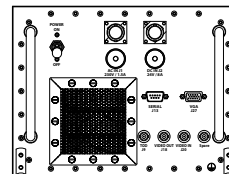

Rear View

BACKPLANE MAPPING

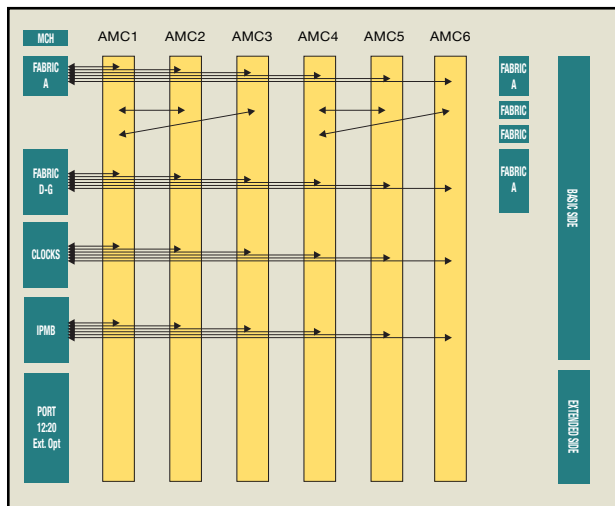

ENVIRONMENTAL

Operating	Storage / Transit
Temperature: 0°C to +50°C	-20°C to +70°C
Altitude: 15000 ft.	50,000 ft. (15,240m)
Humidity: 0% to 95% Non condensing	0% to 95% Non condensing
Shock: 15 Gs @ 11ms	25 Gs @ 11ms (per ASTM 0775)
Vibration: 15-2000 Hz @ .1g2/Hz _(RMS/12G)	15-2000 Hz @ .1g2/Hz _(RMS/12G)
Agencies: Designed to meet UL 1950, FCC Class A or B, CE	

CUSTOM CONFIGURATIONS



NUMBER OF AMC SLOTS
Example: 01 = 1, 10 = 10

MODULE SIZE
S = Single Module
D = Double Module
Z = Combination
X = Not Installed

MODULE SIZE (PITCH)
3 = Compact (3HP)
4 = Mid-Size (4HP)
6 = Full-Size (6HP)
Z = Combination

FABRIC TOPOLOGY
K = Single Star
L = Dual Star
X = Not installed
Z = Custom

HEIGHT
T = Tall
S = Short

WIDTH
A = 1/2 (123.95mm)
B = 3/4 (190.5mm)
C = 1 257.05mm)
D = 1 1/2 (390.65mm)

DEPTH
L = Long (498mm)
S = Short (320.5mm)

MODULE ORIENTATION
V = Vertical (Default Std)

PSU INPUT
C = 90 - 230VAC (Fixed)
G = 90 - 230VAC (Plug in)
H = 48VDC (Plug-in)
K = 48VDC (Fixed)
M = Dual 48VDC (2xHS, N+1)
P = 90 - 230VAC(2 x HS, N+1)
X = No PSU
Y = 24V Plug in
Z = Dual 24V Plug in

PSU OUTPUT
(NOT ALL PSU COMBINATIONS AVAILABLE)
2 = 200 - 299 watts
3 = 300 - 399 watts
4 = 400 - 499 watts
5 = 500 - 599 watts
X = Not Installed

MCH
S = 200 - 299 watts
D = 300 - 399 watts
X = Not Installed

JSM
Y = Installed
X = Not Installed

COOLING
P = PUSH Cooling
R = Redundant Push-Pull
X = Not Installed

ECP - Embedded Computing Products



Elma's Embedded Computing Products, designed and marketed under the ACT/Technico brand, provides innovative solutions with best in class partner products, our own line of storage and I/O products, and over 100 man-years of system integration experience. We also provide ruggedized solutions to meet the most demanding environmental requirements. Certified to ISO 9001, the company supplies integrated embedded systems to companies in defense/aerospace, homeland security, semiconductor equipment, communications, energy, and transportation industries.

Elma Electronic is the premier electronic packaging expert and offers best in class embedded board level products and services. Experience enables us to provide you with the right embedded system platform for your program needs. To support this effort, we have a first-class offering of standards based products – single board computers, mass storage, networking, device drivers, and more. We take true COTS products, such as single board computers and PMCs, then enhance and qualify them to meet project requirements.

The next several pages offer a brief overview of the product categories and services available. Please visit our website or contact your sales representative for complete listings and further details.



STORAGE

Innovative Embedded Mass Storage Solutions

- Direct Attached Storage (DAS)
- Network Attached Storage (NAS) / RAID 0 - 5
- Removable drives / Hot Swap & FRU
- Data Security Solutions:
 - Secure-Erase
 - Write-Protect

DRIVE FORM FACTORS: 1.8", 2.5" & 3.5" & CF

- Rotating
- Solid state flash
- Optical (CD/DVD)
- Tape drives

BOARD FORM FACTORS:

- PMC/XMC/AMC
- CPCI, PICMG 2.16
- ATCA & MicroTCA



SINGLE BOARD COMPUTERS & BLADES

From legacy to latest technologies

PROCESSORS SUPPORTED:

- PowerPC
- PowerQUICC
- Intel architectures
- Single and multicore processors

FORM FACTORS:

- CPCI, PICMG2.16
- ATCA, MicroTCA
- PrPMC/AMC

- COTS Ruggedization Program: Enhanced and/or modified standard products
- Extending board temperature ranges
- Conduction cooled



NETWORKING

Full range of Ethernet solutions

SWITCHES AND CONTROLLERS:

- Fast (10/100), Gigabit and 10 Gigabit Ethernet
- Up to 26 ports in a single slot
- Copper / Fiber (Optical)
- Layer 2 and full wire speed Layer 3
- IPv4 & IPv6
- Multicast / Unicast
- Standard, extended temp and conduction cooled versions

BOARD FORM FACTORS:

- PMC/XMC
- CPCI, PICMG 2.16
- ATCA, μ TCA

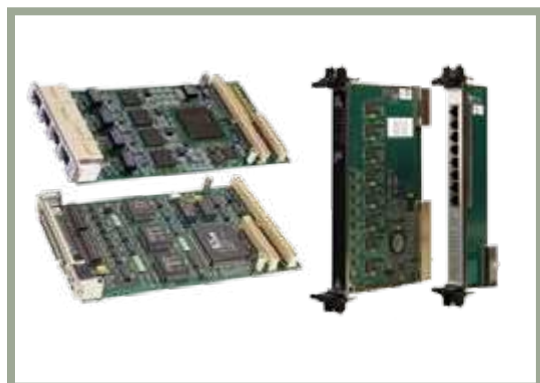

I/O PRODUCTS

Wide range of available solutions

FUNCTIONS:

- Audio and video
- Serial, parallel, binary
- Network Interface Controller (NICs)
- SCSI / ATA
- A/D and D/A channel converters
- 1553, ARINC
- Motion control, CANbus
- FPGA based

FORM FACTORS:

- PMC / XMC / AMC
- 3U & 6U CPCI /PICMG 2.16

ECP - Embedded Computing Products



APPLIPAKS SBC AND I/O "BRICK"

Level Application Development Systems

The Elma AppliPak is a bundled, single procurement source. When you need to ensure that the Single Board Computer you order from us works with specific mezzanines, we can provide the SBC and the modules in a "brick" assembly. We'll bundle the boards under a single model number, qualify and test the assembly before shipment. A typical bundle includes a PowerPC or Intel SBC; Windows, Linux or VxWorks; boot file and drivers; choice of mass storage on PMC or 6U boards, and I/O options such as SCSI, Ethernet, digital I/O and audio. An AppliPak may also include Rear Transition Modules or Breakout Boards. The bricks are available in standard and rugged versions.

Elma can extend the environmental capabilities of your AppliPak with mechanical enhancements, temperature screening, and conformal coating. Each unit is fully tested and a full documentation package is available, including qualifications, manufacturing and test data.



SYSTEMPAKS

Application Development System Platforms

This takes the AppliPak to the sub-system platform level by bundling the board set into a fully integrated and tested subsystem assembly, ready for application development. Available for all standard bus architectures, it is configured, tested and shipped in a chassis suitable for the environment in which it will be used.



SUBSYSTEMS

Integrated Sub-Systems

Our embedded sub-system solutions bring the bundle concept one step further, by providing the full range embedded package. They are designed to provide a complete platform upon which our customers build their integrated systems.

Typical systems might include powered chassis with SBC(s), mass storage, rear transition modules, audio and video modules, Ethernet or fabric switch(es), the operating system and any necessary drivers. We work with you to manage the project through it's entire life cycle.



RUGGED PRODUCTS

Standard COTS products enhanced for rugged environments

We can take true COTS products, such as single board computers and PMCs, then enhance and qualify them to meet project requirements. We offer a growing supply of conduction cooled boards as well as conformal coating for salt spray environments. We qualify boards and systems to the environmental standards of MIL STDs 810F, 901D and 167, and 461. We also design and prepare these products for barge testing.

We offer conformal coating per MIL STD I-46508 where required, and can extend the temperature range of COTS boards when needed.



SERVICES

Designed to fully support the total embedded solution

To support our efforts in providing you with the level of embedded solutions you require, we offer a full complement of services. A platform solution might include any or all of the following: design & build plans, procurement, full product documentation, test services and plans, manufacturing, software installation, project management such as inventory & spares maintenance.

We can do pcb and mechanical design, full doc package support, and testing services. We also offer OS configuration and install along with device drivers.

Test Extender Boards • μ TCA



FEATURES:

- Complies with MicroTCA.0, AMC.1 R1.0, AMC.2 D0.96A
- Extends board outside of the card cage for easy test or de-bug
- Extends all fabric signals, 3 clock lines
- Virtually zero power consumption
- Metal frame holds board securely
- Management and payload power can be individually switch isolated

DIMENSIONS

- Overall length (including guide rail at front): 30.8 cm
- Width (average): 7.35 cm
- Maximum Width: 8.55 cm

MECHANICAL SPECIFICATIONS

- 8U x 711.2mm

ORDERING INFORMATION

TYPE	HEIGHT	LENGTH	PART NUMBER
μ TCA	3U	308mm	69-EXT-330- μ TCA

Load Boards • μ TCA



FEATURES AMC:

- Compliant to MicroTCA.0 specification
- Compliant to PICMG AMC.0: Advanced Mezzanine Card Specification R2.0
- AdvancedMC load board with IPMI support
- Single module, full size
- Configurable load by:
 - IPMI commands
 - Selectable button on front panel
 - Incorporates JTAG interface
- Dynamic, configurable load
- Redundant operation with automatic switchover
- On-board temperature sensors
- Order Number: 69-M-LB-AMC
- Power supply loading can be controlled with front panel switches

ORDERING INFORMATION

TYPE	HEIGHT	LENGTH	PART NUMBER
AMC	3U	180mmmm	69-M-LB-AMC

COM, MCH



The two main functions of an MCH are system management (i.e. IPMI controlled power management, electronic keying, hot-swap of AMCs) and Ethernet switching. The MCH provides those functions for up to 6 AMCs - designed as a single PCB solution with one MCH tongue. Unlike in the telecommunication segment, where advanced feature sets require managed switches with complex control software, such features are not required in most industrial applications. The MCH contains an unmanaged BCM5396 Ethernet switch, which allows to simplify the design and to improve costs (lower cost components, no switch controller, no software for switch controller). Among the typical applications are image processing in the industrial environment or medical environment, industrial control systems, information systems for trains and simple communication systems without the need for managed switches. standard LED indicators, there are status LEDs for 13 GbE ports (Fabric [A] and MCH update channel) on the front, as well as RJ45 connectors for one management interface and one serial interface to access the management controller (MCMC).

For management functions the MCH contains a MCMC LPC2368 with IPMI software. The MCH supports IPMB-L links to up to 12 AMCs, I2C to the SEEPROM on the backplane, and I2C as well as IPMB-0 [A:B] links for power management and cooling. A JTAG connection is also provided.

The MCH represents a an MCH designed according MicroTCA.0 with a cost improved design. It supports the Kontron family of cost optimized MicroTCA platforms, as well as a range of other 3rd party platforms. The MCH helps customers to address with MicroTCA a broader range of applications. The choice of the MCH is a perfect fit for designing a complete and highly versatile MicroTCA platform that is cost-effective by focusing to the application needs.

The MCH provides one GbE uplink on front, and on the edge connector 12x GbE for AMCs (Fabric [A]) plus 1x GbE for the MCH update channel.

ORDERING INFORMATION

SIZE	DESCRIPTION	PART NUMBER
Single, Mid	MCH	69-MCH-S4-CXXX

Power Modules



DESCRIPTION

The MicroTCA Power Module serves as the interface between its MicroTCA system and the system power source and provides the following main functions:

- Accepts and conditions input power
- Converts and distributes power to MicroTCA Carrier Hub (MCH), AdvancedMC and Cooling Unit (CU)
- Monitors power, protects against faults and limits power consumption
- Works with MicroTCA Carrier Hub (MCH) to control and manage power
- 380 Watt
- 90 - 230VAC input
- Single module, mid - size

ORDERING INFORMATION

SIZE	DESCRIPTION	PART NUMBER
Single, mid	380 Watt, μ TCA Power Mod	69-PM-S4-C3

EMMC (Enhanced Module Management Controller)



DESCRIPTION

EMMC is used for the management of cooling modules. The ELMA cooling units communicate according to the MicroTCA specification via IPMI messages with the MCH. The EMMC controls the fans in the fan cassette via PWM or two different analogue voltages.

FEATURES:

- Cooling unit EMMC with IPMI support
- Monitors up to eight 12V fans
- Support for up to eight LM75 temperature sensors
- Fan speed control by:
 - PWM signal
 - variable voltage (max 2A)
- On-board temperature sensors
- Board size: 115mm x28mm
- Op temp range: -10 deg c to 70 deg C
- Storage temp range: -40 deg C to 105 deg C

ORDERING INFORMATION

DESCRIPTION	PART NUMBER
Cooling Management	69-EMMC-XXXX

Air Block Modules (Slot Bypass Board)



DESCRIPTION

The slot bypass boards fill unused slot positions in the system enclosure. Elma's bypass boards block airflow whenever there were empty slots in your enclosure and ensure airflow is directed to the occupied slots where it is needed. Made of rigid construction, our bypass boards act as an effective barrier while maintaining the integrity of the enclosure's airflow system. Ejectors and injectors are optional and make these boards easy to remove when you need the slots for system expansion. Elma bypass boards are available in all VITA & PICMG sizes. Insulated boards are also available standard. Metal versions can be specially ordered. Bypass boards are supplied in assembled form only.

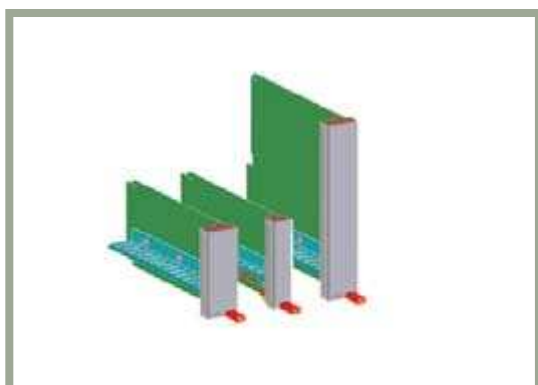

FEATURES:

- Blocks airflow in unused slots
- Available for all Euro Card sizes (3U-9U, VITA & PICMG)
- Ejectors and Injectors available
- Plugs directly into empty slots
- Made of rigid construction
- Directs airflow properly for optimal system cooling

AIR BLOCK MODULES

AMC air block modules can be used to fill empty slots in the card cage and re-direct airflow. The modules block the air from the inserted slot and force it to adjacent slots. This provides 10-50% of adjustable redirected airflow. The units come in single/mid, single/full or double/full sizes.

ORDERING INFORMATION

CARD SIZE	ORDER NUMBER
3U x 160mm, 4HP	80-316JB-00
6U x 160mm, 4HP	80-616JB-00
6U x 220mm, 4HP	80-622JB-00
6U x 340mm, 4HP	80-634JB-00
9U x 400mm, 4HP	80-940JB-00

MicroTCA Backplanes

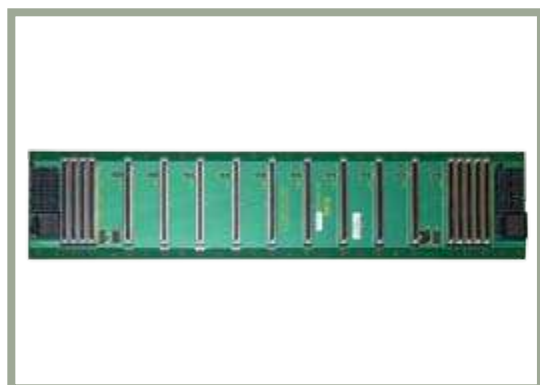

FEATURES:

- Complies to MicroTCA.0 Specification Rev 1.0
- Slot to slot aggregate bandwidth of 5,000 Mbytes/sec
- Approximately 3U height
- Star Backplane
 - 12 AMC, 1 MCH, 1 power module (full size)
- Dual Star Backplane
 - 10 AMC, 2 MCH, 2 power modules (full size)
- Modular and serviceable
- Standard shelf management - MicroTCA Carrier Hub (MCH)
- Compression-mount connector easily replaceable
- Optimized via signal integrity studies, reports available upon request
- Other versions available in various configurations-compact and mid size, cube and pico style

MECHANICAL SPECIFICATIONS

- Slots: 10 AMC, 2 MCH, 2 Power Module slots (all full size)
- Height: 3U
- Full size modules
- Compression-mount connector standard

BOARD SPECIFICATIONS

- 26-layer board
- 2 oz. copper power and ground
- PCB UL recognized 94V-0
- PCB FR-4 or equivalent
- PCB .195" thick

ELECTRICAL/OPERATING SPECIFICATIONS

- Conforms to: IEC 68/1:25/085/21
- Operating temperature: -40 C to +85 C
- Storage temperature: -55 C to 85 C
- Tx/Rx pair impedance: 100 Ohm +/- 10 %

ORDERING INFORMATION

SLOTS	HEIGHT	DESCRIPTION	PART NUMBER
14	3U	10 AMC, 2 power, 2 MCH slots, all in full size	69-MK310-VP14
14	3U	12 AMC, 1 power, 1 MCH slot, all in full size	69-MK312-VP14
10	3U	6 AMC, 1 power, 1MCH slot, all in full size	69-MK306-VP10

MicroTCA MicroSlim (TM) Backplanes

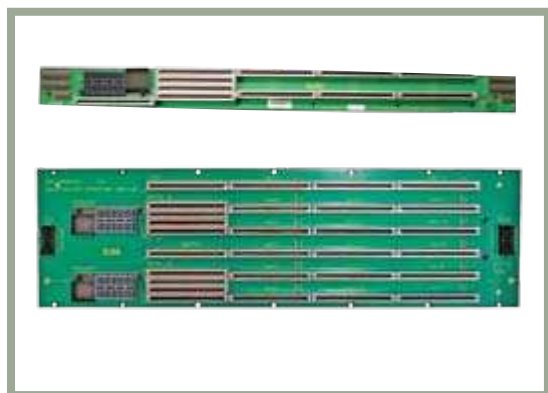

FEATURES:

- Complies to MicroTCA.0 Specification Rev 1.0
- Star and Dual Star Topology options
- Optimized via signal integrity studies
- Compression-mount connectors for improved performance, reliability and field replacement capability
- Passive and active versions available
- Active version has IPMB-0 intelligence for power and cooling unit installed across the backplane
- Active version has direct PCIe, GbE, XAUI and SATA connections

ACTIVE MICROSLIM BACKPLANES

The Active 1U MicroSlim Backplane is designed for low-cost MicroTCA systems with simplified power management. Instead of having IPMI management across all the FRU's, the active backplane has IPMB-0 for power and cooling unit management across the backplane. There are also direct PCIe, GbE, XAUI and SATA connections. The active backplane features a 4-pin power connector for a pluggable PSU and a control handler. There is a 12V to 3.3V converter on the backplane. But the payload and management power is managed, not distributed. Standard MCHs can be used with the active backplane.

MECHANICAL SPECIFICATIONS

- 1U, 3U heights
- Full size modules
- Compression-mount connector standard

BOARD SPECIFICATIONS

- 20-layer board (passive 1U), 14-layer board (active 1U), 24-layer board (3U)
- 2 oz. copper power and ground
- PCB UL recognized 94V-0
- PCB FR-4 or equivalent
- PCB .195" thick (passive 1U), PCB .167"

ELECTRICAL/OPERATING SPECIFICATIONS

- Conforms to: IEC 68/1:25/085/21
- Operating temperature: -40 C to +85 C
- Storage temperature: -55 C to 85 C
- Tx/Rx pair impedance: 100 Ohm +/- 10 %

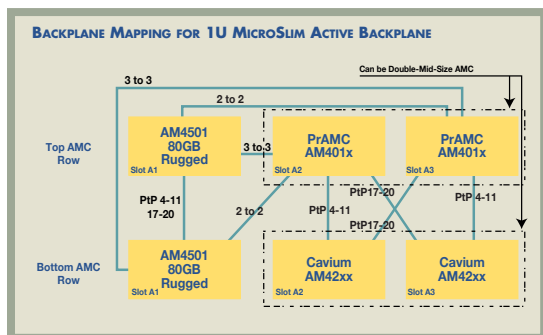

ORDERING INFORMATION

SLOTS	HEIGHT	DESCRIPTION	PART NUMBER
9	1U	Passive: 6 AMC, 1 PM, 1 JSM, 1 MCH and 2 CUs (Cooling Units)	69-M-106-HP09
24	3U	Passive: 12 AMC, 4 HDD (w/SATA), 2 PM, 2 MCH, 1 JSM, 3 spare slots and 2 CUs (Cooling Units)	69-M-312-HP24
9	1U	Active: 6 AMC, 1 PSU connector, 1 MCH, and 2 CUs (Cooling Units)	69-M-106-HA09

MicroTCA Cube Backplane



FEATURES: Cube

- According to PICMG MicroTCA.0 Rev. 1.0
- Compression style connectors easily replaceable
- 6 AdvancedMCs, 1 MCH, 1 power module (all full size)
- 12-layer board
- Direct connections for storage protocols
- Support of direct pluggable IPMI controlled fan trays
- Support of all FRU (Field Replaceable Unit) functions
- Support of PCI Express due to Fabric Clock routing

ORDERING INFORMATION

SLOTS	HEIGHT	DESCRIPTION	PART NUMBER
8	6U	6 X AMC, 1 X MCH, 1 X Power	69-MK608-VP08

MicroTCA ComBlue Backplane



FEATURES: ComBlue

- High-speed routing is effected by means of single Star technology
- 12 layer structure
- A maximum of 5 single module AMCs (2 full size and 3 mid size modules)
- Support of all FRU (Field Replaceable Unit) functions
- IPMI controlled fan

ORDERING INFORMATION

SLOTS	HEIGHT	DESCRIPTION	PART NUMBER
5	4U	5 X AMC / 2 full and 3 md	69-MK405-VA05

Card Guides - Standard • Anti-Vibration



STANDARD

- Fits on extrusion 66-242-X
- Top and bottom use of card guide
- Plastic, UL94 V-0
- ESD clip can be assembled at front and rear

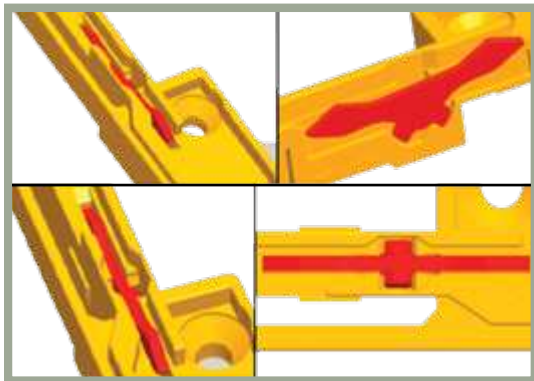

ANTI-VIBRATION

- Simple geometry for simple fabrication (milling or stamping)
- Material - metal or polymer/plastic
- Wing = locking/clamping and addition centering mechanism
 - Two line contact areas as support
 - Works like a technical compensator with flexible attributes
 - Can lock AdvancedMC Modules with normal Card Edge Interface and Moduls with MCH-Plug-Connector
 - Mechanism increases the operating safety

ORDERING INFORMATION

SIZE	DESCRIPTION	PART NUMBER
AMC	Standard	61-193-00-2
AMC	Anti-Vibration	61-193-00-2R

MicroTCA ESD Clip



FEATURES:

- Fits on μ TCA card guide 61-193-00
- Stainless steel
- Additional space for customer logo on top
- Logo integrated in die-cast is possible
- Extruded panel has improved aesthetics
- Machined or stamped panel cut-outs, tight radiuses

ORDERING INFORMATION

DESCRIPTION	PART NUMBER
μ TCA ESD Clip	61-194-12

MicroTCA Handles/Panels

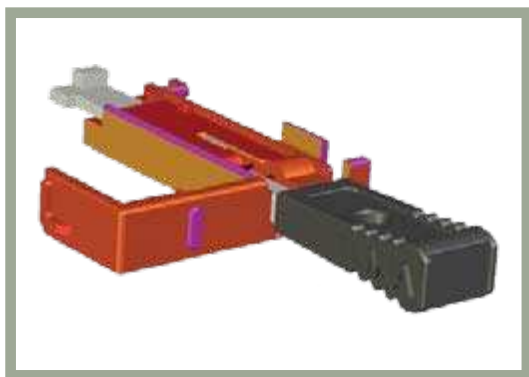

Elma offers standard and customized MicroTCA handles and front panels. With Elma's superior quality and precision milling, even the toughest of tolerances can be achieved.

FEATURES:

- Ergonomic design, grooves for easy handling
- Custom designs and colors available
- Additional space for customer logo on top
- Logo integrated in die-cast is possible
- Extruded panel has improved aesthetics
- Machined or stamped panel cut-outs, tight radiuses

ORDERING INFORMATION

DESCRIPTION	PART NUMBER
μ TCA Handle	CAE-1823

LOCATIONS

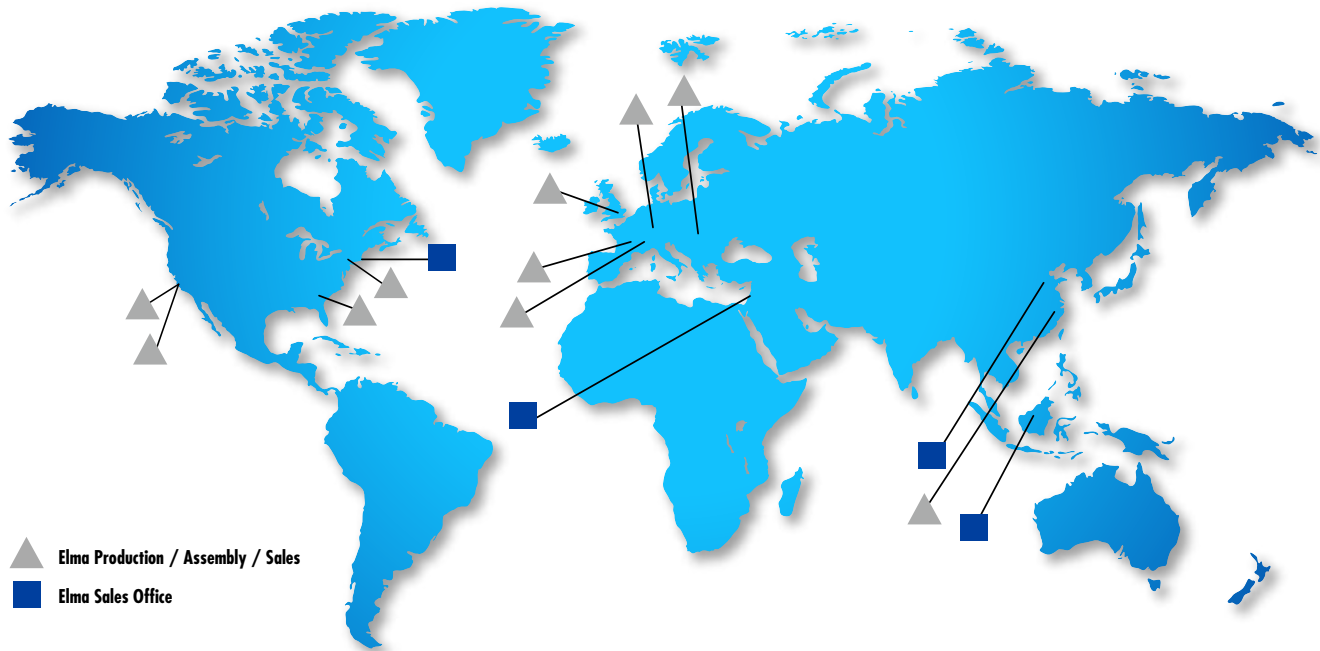

- ▲ Elma Production / Assembly / Sales
- Elma Sales Office

ELMA ELECTRONIC/OPTIMA

Elma Electronic/Optima EPS
1775 MacLeod Drive
Lawrenceville, GA 30043
Phone: (770) 496-4000
Fax: (770) 496-4041
sales@optimaeps.com
www.optimaeps.com, & www.elma.com

UNITED STATES, ELMA ELECTRONIC

Elma Electronic US Headquarters
44350 Grimmer Blvd.
Fremont, CA 94538
Phone: (510) 656-3400
Fax: (510) 656-3783
sales@elma.com
www.elma.com

Elma Electronic Inc.
760 Veterans Circle
Warminster, PA 18974
Phone: 215-956-1200
Fax: 215-956-1201
sales@acttechnico.com
www.acttechnico.com

ELMA BUSTRONIC

Elma Bustronic Headquarters
44350 Grimmer Blvd.
Fremont, CA 94538
Phone: (510) 490-7388
Fax: (510) 490-1853
sales@elmabustronic.com
www.elmabustronic.com

SWITZERLAND

Elma Electronic AG
Hofstrasse 93, Postfach
8620 Wetzikon
Phone: +41 44 933 41 11
Fax CH: +41 44 933 42 15
Fax Inter: +41 44 932 38 12
sales@elma.ch
www.elma.com

CHINA

Elma Electronic China
8F, 355 Fu Te Road (West1)
Wai Gao Qiao Free Trade Zone
Pudong District, Shanghai 200131
Phone: +86 21 5866 5908
Fax: +86 21 5866 5918
sales@elmachina.com
www.elma.com

ASIA PACIFIC

Elma Asia Pacific Pte. Ltd
115-A Commonwealth Drive
#03-14 Tanglin Halt Industrial Estate
Singapore 149596
Phone: +65 6479 8552
Fax: +65 6479 8662
sales.elmaap@elma.com
www.elma.com

GERMANY

Elma Trenew Electronic GmbH
Stuttgarter Strasse 11
D-75179 Pforzheim
Phone: +49 7231 97 340
Fax: +49 7231 97 3497
info@elma.de
www.elma.com

UNITED KINGDOM

Elma Electronic UK Ltd
Solutions House, Fraser Road
Priory Business Park
Bedford MK44 3BF
Phone: +44 (0)1234 838822
Fax: +44 (0)1234 836650
info@elma-mektron.co.uk
www.elma.com

ISRAEL

Elma Electronic Israel Ltd.
34, Modi'in St.
IL.Z. Sgula
Petach-Tikva 49271
Phone: +972 3 930 50 25
Fax: +972 3 931 31 34
sales@elma.co.il
www.elma.com

FRANCE

Elma Electronic France SASU
ZA du Buisson Rond
F-38460 Villemoirieu
Phone: +33 4 37 06 21 10
Fax: +33 4 37 06 21 19
sales@elma-electronic.fr
www.elma.com

ROMANIA

Elma Electronic SRL
Maltozol Nr.16 Street, sector 1
RO-011048 Bucuresti
Phone +4021 310 7998
Fax +4021 310 7992
info@elma.ro
www.elma.com