

## Regulatory Compliance

The Polaris has been tested under the following specifications: NEBS, ETSI, FCC, UL, and CE. For full information on these tests, please call our office or visit our website.

### NEBS and ETSI Specifications

#### ETSI

The Polaris family of systems meets the requirements of the European Telecom Standard (ETSI) including:

- *Equipment Engineering (EE): Environmental conditions and environmental tests for telecommunications equipment*, ETS 300 019-1-3
- Storage: ETS 300 019-1-1, for Class 1.2E equipment
- Transportation: ETS 300 019-1-2 for Class 2.3 equipment

#### NEBS

The Polaris family of systems meets the requirements of the Bellcore standards, *Networking Equipment Building System (NEBS) Requirements: Physical Protection, GR-63-CORE and Electromagnetic Compatibility and Electrical Safety - Generic Criteria for Network Telecommunications Equipment, GR-1089-CORE*. The product has been tested to the requirements for NEBS Level 3 criteria.

### Other Regulatory Compliance

ACT/Technico's configured systems meet or exceed the following:

- Safety: CSA NRTL/C, VDE EN60950, CE Mark per European Low Voltage Directive 72/23/EEC  
EMC: U.S.: FCC Part 15, Subpart B, Class A  
Canada: ICES-003, Class A  
Europe: CE Mark per European EMC Directive 89/336/EEC with Amendments; Emissions: EN55022 Class A; Immunity: EN50082-1

## Order Information

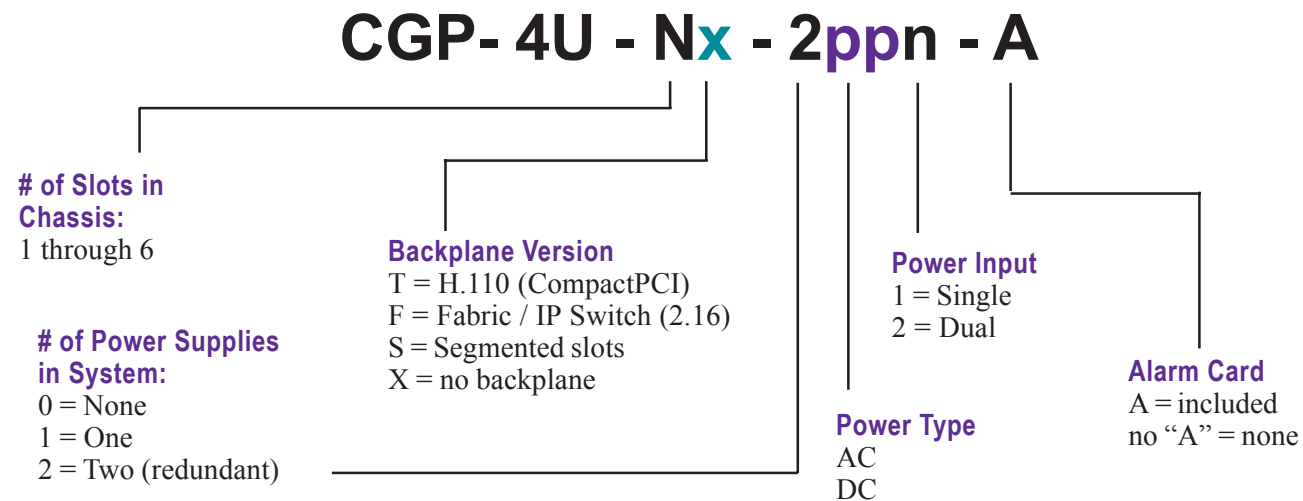

*Systems By Design*  
[www.acttechnico.com](http://www.acttechnico.com)



One Ivybrook Boulevard, Suite 180, Ivyland, PA 18974 .

Tel: (800) 445-6194 or (215) 957-9071. Fax: (215) 957-9074 . E-Mail: [sales@acttechnico.com](mailto:sales@acttechnico.com)



PowerPC is a registered trademark of International Business Machines Corporation. Intel and Pentium are registered trademarks of Intel Corporation. PICMG and CompactPCI are registered trademarks of PCI Industrial Computer Manufacturers Group. All other names, products, and/or services mentioned may be trademarks or registered trademarks of their respective holders.

Printed in USA -P6S-PDF-0803



## Polaris System Chassis

*4U Hot Swap & High Availability*

- Perfectly suited for space-sensitive applications
- Designed with hot swap components for high availability
- Robust design is well suited to NEBS & ETSI applications or EMI/RFI requirements
- System design accommodates a variety of configurations.



### Features:

- ❑ Compact, 4U chassis
- ❑ Six standard or segmented CompactPCI slots
- ❑ Available with PICMG 2.16 compliant backplane
- ❑ Dual redundant, N+1 hot swap compliant power supplies
- ❑ Dual fan modules, hot swap compliant, with front to rear air flow
- ❑ Alarm card monitors multiple functions
- ❑ Available with or without a choice of CPU architectures - SPARC, PowerPC, or Pentium on 6U CompactPCI boards
  - Choice of on-board PMCs according to slot availability and requirements
  - Rear I/O transition modules with PIMs (PMC Interface Modules) for maximum system configurability
- ❑ System is fully configured, assembled, and tested per your unique application configuration requirements
- ❑ Designed for a wide variety of communications applications
- ❑ Compliance: NEBS, ETSI, FCC, CSA, ICES and CE.

## Standard Features

### Compact, 4U Chassis

Dimensions: 4U (7")H x 19"W x 15"D

### Standard or segmented CompactPCI backplane

6 slots with front and top access service to backplane.

### Dual Power Supplies

250 Watt, N+1 redundant and front accessible.

### Dual Fan Modules

Hot swap compliant and removable from the front. Air intake filter is easily accessible and removable for replacement.

### 6U CompactPCI SBCs

Currently supported: SPARC, PowerPC, and Pentium

### PCI Mezzanine Cards (PMCs):

Each SBC is capable of hosting one or more PMC modules.

### Rear I/O Transition Modules

80 mm boards with PIMs (PMC Interface Modules).

### Power Inlet Module

Installed in the rear of the chassis. Supports single or multiple AC and DC power sources.

### Alarm Module

Provides alarm control, reporting and front panel fault indication. Hot swappable, with two serial ports for interface to monitoring host CPU.

### System Integration

System comes fully installed and wired with a single bundled part number.

### Operating System(s)

VxWorks, Solaris, and Linux operating systems are supported on the mentioned SBCs. Visit our website or contact your local sales representative for up to date OS support.

### Ordering Information:

See page 4 for full ordering details.

For customized configurations, please contact your local ACT/Technico sales office.

## Specifications

### Compact, 4U Chassis

The Polaris chassis has been designed to fit into space constrained telecommunications environments. Dimensions: 4U (7")H x 19"W x 15"D

### Standard or Segmented CompactPCI Backplane

Supports standard six-slot CompactPCI backplane with H.110 option, or non-bussed individual slots (other backplane configurations available on request). Top access service to backplane via a removable panel.

### Dual Power Supplies

250 Watt, CompactPCI plug-in power supplies plug directly into backplane for distribution to all slots. The supplies are N+1 redundant, featuring diode isolation. Active current sharing and overvoltage protection is also supported. Front accessible.

### Dual Fan Modules

Hot swap compliant. Fan modules plug directly into the backplane and are removable from the front. Fan speeds are monitored via tachometer outputs.

### Power Inlet Module:

Installed in the rear of the chassis. Enables easy installation of different power inlet modules, supporting both AC and DC power sources.



Power Supply Modules

### Power Supply Specifications

DC Output	Max Load	Regulation	Ripple
+ 5.0 V	25 A	2%	1% pp
+ 3.3 V	30 A	2%	1% pp
+ 12.0 V	5 A	2%	1% pp
- 12.0 V	.5 A	2%	1% pp

### Alarm Module

The Alarm Module connects to the backplane and provides alarm control, reporting and front panel fault indication. The Alarm Module provides two serial ports for interface to monitoring host CPU. Hot swappable, it monitors multiple functions:

- Fan speed
- Exhaust air temperature
- Slot healthy status
- Controls resets of each board independently
- Power supply status

### System Integration

The system comes fully integrated and wired, including installation of the CPUs, power supplies, alarm card, fan modules, and all necessary PMCs and Transition Modules with PIMs. The Polaris chassis can be installed and wired into an equipment rack as well.

### Operating Systems

The Polaris can be supplied with most major real time operating systems as well as Solaris®, Linux® and Windows®. For more information on Operating Systems vendors who support ACT/Technico CompactPCI boards, please visit our website at <http://www.acttechnico.com>.

### Complete Specifications:

For more complete information on specific CPU architecture and specifications, please contact your local ACT/Technico sales office or go to our website at <http://www.acttechnico.com>.

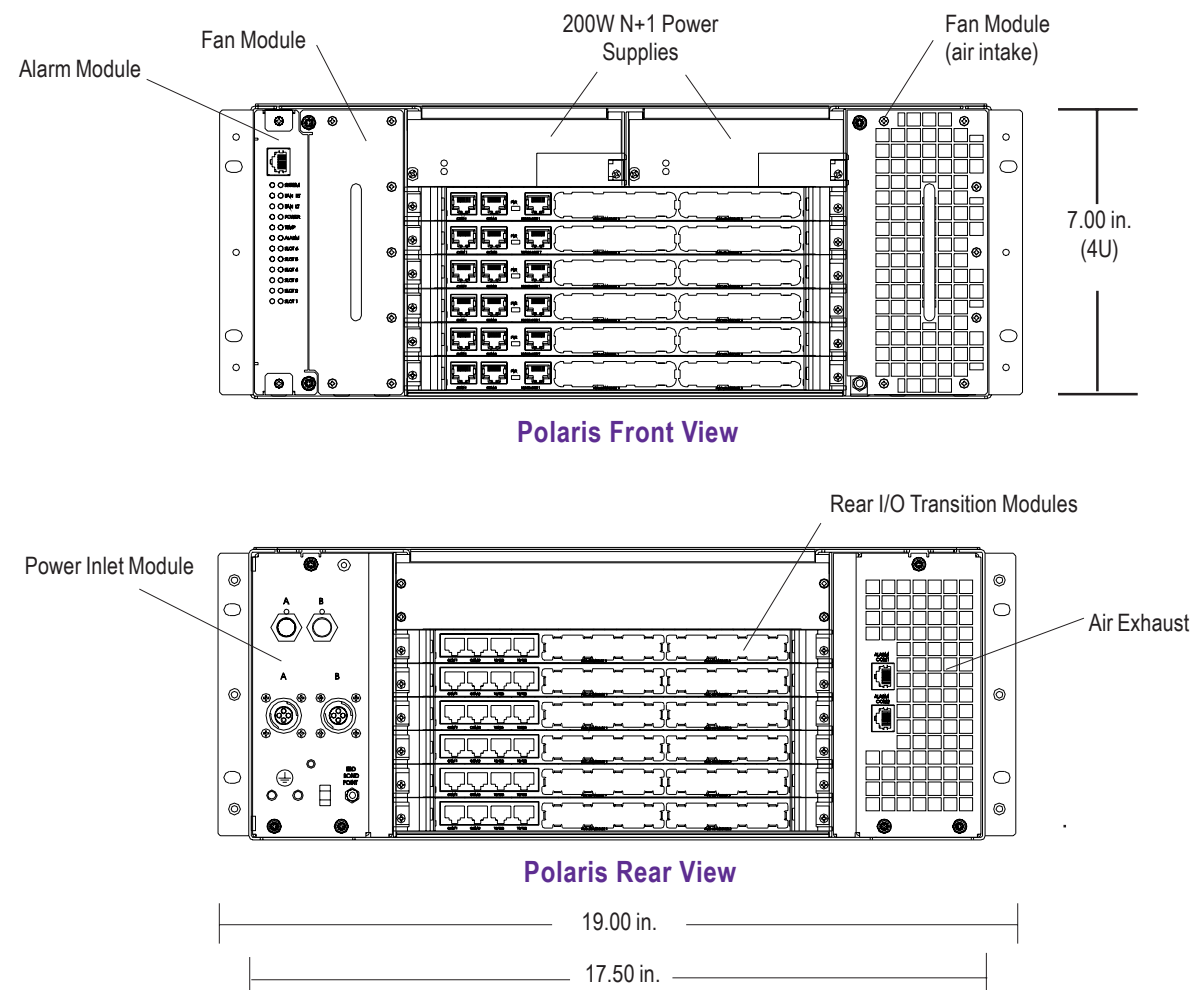

## System Options

### • Choice or mix of CPU architectures

6U CompactPCI board platforms:

- SPARC® options: UltraSPARC™ IIe, IIi
- PowerPC® options: MCP750, MCP765
- Intel options: Pentium III, Pentium 4-M

### • PCI Mezzanine Cards (PMCs):

Each CompactPCI CPU is capable of hosting one or more PMC modules. For more information on PMC modules visit our website at <http://www.acttechnico.com>.

### • Rear I/O Transition Modules

80 mm boards with PIMs (PMC Interface Modules). The Transition Modules and PIMs are available to suit multiple design requirements. Visit our website for more information on these products.



Rear View of Polaris