

1A Linear Li-Ion Battery Charger for Single and Dual Cell Applications

General Description

The AAT3663 BatteryManager™ is a member of Skyworks' Total Power Management IC™ family. This device is an integrated single/dual cell Lithium-Ion (Li-Ion) / polymer battery charger IC designed to operate from USB ports or an AC adapter inputs up to an input voltage of 13.2V.

AAT3663 precisely regulates battery charge voltage and current for 4.2V and 8.4V Li-Ion battery cells. The battery charging current is user programmed up to 1A by an external resistor.

Battery charge state is continuously monitored for fault conditions. A Digital Thermal Loop Control maintains the maximum possible battery charging current for the optimum set of input to output power dissipation and ambient temperature conditions. In the event of an over-current, over-voltage, short-circuit, or over-temperature fault condition, the device will automatically shut down, thus protecting the charger and the battery under charge.

Two status monitor output pins are provided to indicate the battery charge status by directly driving external LEDs. Additionally, an open-drain power-source detection output (ADPP#) is provided to report presence of an input power supply

The AAT3663 is available in a thermally enhanced, space-saving, 14-pin 3 × 3 mm TDFN package and is specified for operation over the -40°C to +85°C temperature range.

Features

- 4.0V ~ 13.2V Input Voltage Range
- Compatible with USB or AC Adapter Sources
- Programmable Fast Charge Current from 100mA to 1A
- Programmable Charge Termination Current
- Digital Thermal Loop Charge Reduction
- Less Than 0.4µA Battery Leakage Current
- Programming Charge Timer
- Battery Temperature Sensing
- Battery Temp Sense Open Circuit Detection
- Automatic Recharge Sequencing
- Automatic Trickle Charge for Battery Pre-Conditioning
- Automatic Charge Termination Shutdown/Sleep Mode
- Less than 1µA Shutdown Current
- Over-Voltage and Over-Current Protection
- Power On Reset and Soft Start
- 3 × 3mm 14-pin TDFN Package

Applications

- Digital Still Cameras
- Global Positioning Systems (GPS)
- Point Of Service (POS) Terminals
- Portable DVD Players
- Portable Media Players (PMP)
- Two Way Radios

Typical Application

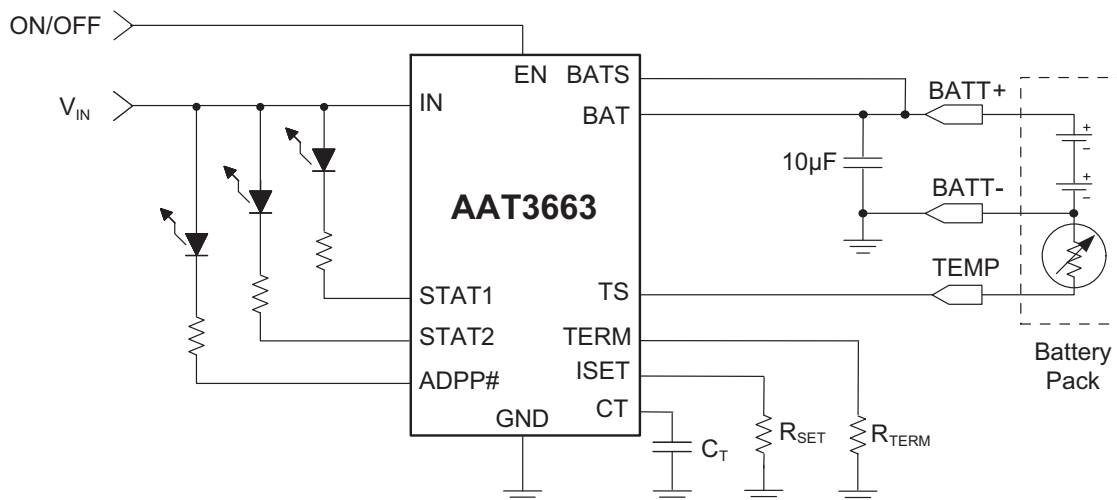

DATA SHEET

AAT3663

1A Linear Li-Ion Battery Charger for Single and Dual Cell Applications

Pin Description

Pin #	Symbol	Type	Function
1	EN	I	Enable pin, Active high with internal pull-down. If not used, pull high to the IN pin to continuously enable the charger IC when input power is applied.
2	CT	I	Charge timer programming pin. A 0.1μF ceramic capacitor should be connected between this pin and GND. Connect directly to GND to disable the timer function.
3	ISET	I	Charge current programming pin. Connect a resistor between this pin and GND to program the constant fast charge current.
4	GND	I/O	IC ground connection. Connect this pin to power ground.
5	TS	I/O	Battery temperature sense input. Connect the Li-Ion battery pack NTC resistor terminal to this pin.
6	BATS	I	Battery voltage sense pin. Connect this pin directly to the positive battery terminal. If this function is not used, connect to the BAT pin directly.
7	BAT	O	Battery charge output pin. Connect to the positive battery terminal.
8, 9	IN	I	Power supply input pin. Connect the input USB port or Adapter power source to this pin
10	STAT2	O	Charge status pin, open-drain output. Connect the STAT2 LED with a series ballast resistor between IN and this pin.
11	STAT1	O	Charge status pin, open-drain output. Connect the STAT1 LED with a series ballast resistor between IN and this pin.
12	ADPP#	O	Input supply power-good status pin, open-drain output. Connect the ADPP# status LED with a series ballast resistor between IN and this pin.
13	TERM	I	Charge termination current programming input pin. Connect a resistor between this pin and GND to program the charge termination current. When TERM is open, the termination current is 10% (default setting) of the set maximum charge current.
14	N/C		No connection.

Pin Configuration

**TDFN33-14
(Top View)**

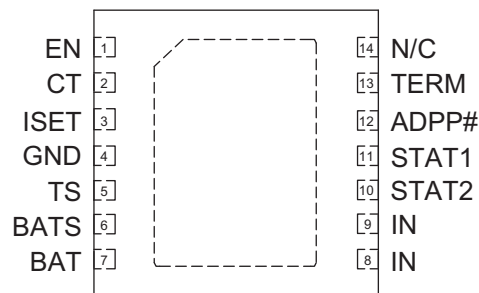

1A Linear Li-Ion Battery Charger for Single and Dual Cell Applications**Absolute Maximum Ratings¹**

Symbol	Description	Value	Units
V_{IN}	IN Continuous Voltage	-0.3 to 14	V
V_N	STAT1, STAT2, ADPP#, EN, BAT, BATS	-0.3 to $V_{IN} + 0.3$	
V_N	TS, CT, TERM, ISET	-0.3 to 5.5	
T_J	Operating Junction Temperature Range	-40 to 150	°C
T_{LEAD}	Maximum Soldering Temperature (at Leads)	300	

Thermal Information²

Symbol	Description	Value	Units
θ_{JA}	Maximum Thermal Resistance (TDFN3x3)	50	°C/W
P_D	Maximum Power Dissipation	2	W

AAT3663 Feature Options

Product	Number of Battery Cells	Battery Temperature Sense
AAT3663-4.2-1	Single	For Use With Any NTC Thermistor
AAT3663-4.2-2	Single	For Use With 10k Ω NTC Thermistor
AAT3663-8.4-1	Dual	For Use With Any NTC Thermistor
AAT3663-8.4-2	Dual	For Use With 10k Ω NTC Thermistor

1. Stresses above those listed in Absolute Maximum Ratings may cause permanent damage to the device. Functional operation at conditions other than the operating conditions specified is not implied. Only one Absolute Maximum rating should be applied at any one time.
2. Mounted on a FR4 board.

DATA SHEET

AAT3663

1A Linear Li-Ion Battery Charger for Single and Dual Cell Applications

Electrical Characteristics

$V_{IN} = 5V$, $T_A = -40$ to $+85^\circ C$; Unless otherwise noted, typical values are at $T_A = 25^\circ C$.

Symbol	Description	Conditions	Min	Typ	Max	Units
Operation						
V_{IN}	Input Voltage Range		4.0		13.2	V
V_{UVLO}	Under Voltage Lockout Threshold	Rising Edge	3		4	V
	UVLO Hysteresis			150		mV
V_{ADPP_TH}	Adapter Present Indicator Threshold Voltage, $V_{IN} - V_{BAT}$	$V_{IN} > V_{UVLO}$		50	100	mV
I_{OP}	Operating Current	Charge Current = 100mA		0.35	1	mA
$I_{SHUTDOWN}$	Shutdown Current	$V_{BAT} = 4.25V$, EN = GND		0.4	1	μA
$I_{LEAKAGE}$	Leakage Current from BAT Pin	$V_{BAT} = 4V$, IN = Open		0.4	2	μA
$EN_{LEAKAGE}$	EN Pin Leakage	$V_{EN} = 5V$		0.6		μA
Voltage Regulation						
V_{BAT_EOC}	End of Charge Voltage Regulation	AAT3663-4.2	4.158	4.2	4.242	V
		AAT3663-8.4	8.316	8.4	8.484	
$\frac{\Delta V_{BAT_EOC}}{V_{BAT_EOC}}$	End of Charge Voltage Accuracy			0.5		%
V_{MIN}	Preconditioning Voltage Threshold	AAT3663-4.2	2.5	2.6	2.7	V
		AAT3663-8.4	5.0	5.2	5.4	
V_{RCH}	Battery Recharge Voltage Threshold	AAT3663-4.2		$V_{BAT_EOC} - 0.1$		V
		AAT3663-8.4		$V_{BAT_EOC} - 0.2$		
Current Regulation						
I_{CC_RANGE}	Charge Current Programmable Range		100		1000	mA
I_{CH_CC}	Constant-Current Mode Charge Current	$R_{ISET} = 1.74K\Omega$ (for 1A), $V_{BAT} = 3.6V$	900	1000	1100	mA
		$R_{ISET} = 17.8K\Omega$ (for 0.1A), $V_{BAT} = 3.6V$	80	100	120	
V_{ISET}	ISET Pin Voltage			2		V
K_{ISET}	Charge Current Set Factor: I_{CH_CC}/I_{ISET}	Constant Current Mode, $V_{BAT} = 3.6V$		900		
V_{TERM}	TERM Pin Voltage	$R_{TERM} = 40k\Omega$		0.6		V
I_{CH_TRK}	Trickle-Charge Current		5	10	15	% I_{CH_CC}
		TERM pin open	5	10	15	% I_{CH_CC}
I_{CH_TERM}	Charge Termination Current Threshold	$R_{TERM} = 13.3 k\Omega$, $I_{CH_CC} \geq 800mA$	8	10	12	% I_{CH_CC}
Charging Devices						
$R_{DS(ON)}$	Charging Transistor ON Resistance	$V_{IN} = 5V$		330	500	m Ω
Logic Control / Protection						
V_{EN}	Input High Threshold		1.6			V
	Input Low Threshold				0.4	
V_{STAT}	Output Low Voltage	STAT Pin Sinks 4mA			0.4	V
I_{STAT}	STAT Pin Current Sink Capability				8	mA

DATA SHEET

AAT3663

1A Linear Li-Ion Battery Charger for Single and Dual Cell Applications

Electrical Characteristics

$V_{IN} = 5V$, $T_A = -40$ to $+85^\circ C$; Unless otherwise noted, typical values are at $T_A = 25^\circ C$.

Symbol	Description	Conditions	Min	Typ	Max	Units
Logic Control / Protection						
$V_{ADDP\#}$	Output Low Voltage	ADPP# Pin Sinks 4mA			0.4	V
$I_{ADPP\#}$	ADDP# Current Sink Capability				8	mA
V_{OVP}	Over-Voltage Protection Threshold	AAT3663-4.2		4.4		V
		AAT3663-8.4		8.8		
V_{OCP}	Over-Current Protection Threshold			105		% V_{CS}
TK	Trickle Charging Time-Out	$C_T = 100nF$, $V_{IN} = 5V$		$T_C/8$		Hour
TC	Trickle and Constant Current Mode Time-Out	$C_T = 100nF$, $V_{IN} = 5V$		3		Hour
TV	Constant Voltage Mode Time-Out	$C_T = 100nF$, $V_{IN} = 5V$		3		Hour
I_{TS}	Current Source from TS Pin	AAT3663-2 Only	71	75	79	μA
T_{S1}	TS Hot Temperature Fault	Threshold, AAT3663-2 Only	316	331	346	mV
		Hysteresis, AAT3663-2 Only		25		
T_{S2}	TS Cold Temperature Fault	Threshold, AAT3663-2 Only	2.30	2.39	2.48	V
		Hysteresis, AAT3663-2 Only		25		
V_{TS1}	High Temperature Threshold	Threshold, AAT3663-1 Only	29.1	30	30.9	% V_{IN}
		Hysteresis, AAT3663-1 Only		2		
V_{TS2}	Low Temperature Threshold	Threshold, AAT3663-1 Only	58.2	60	61.8	% V_{IN}
		Hysteresis, AAT3663-1 Only		2		
T_{LOOP_IN}	Digital Thermal Loop Entering Threshold			115		$^\circ C$
T_{LOOP_OUT}	Digital Thermal Loop Exiting Threshold			85		$^\circ C$
T_{REG}	Digital Thermal Loop Regulation			100		$^\circ C$
T_{SHDN}	Over-Temperature Shutdown	Threshold		140		$^\circ C$
		Hysteresis		15		

1A Linear Li-Ion Battery Charger for Single and Dual Cell Applications

Typical Characteristics—General

Operating Current vs I_{SET} Resistor

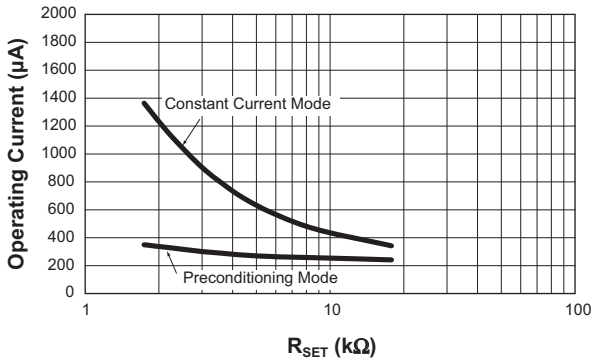

Constant Charging Current vs. Set Resistor Values

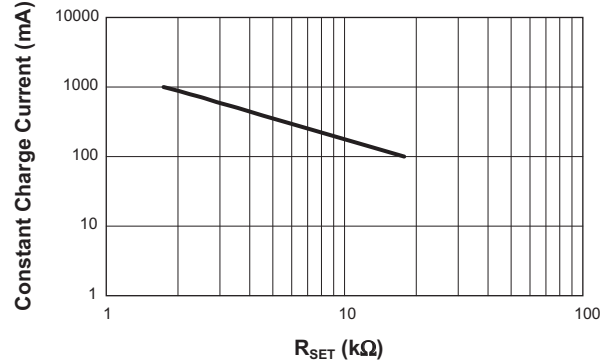

Temperature Sense Output Current vs. Temperature

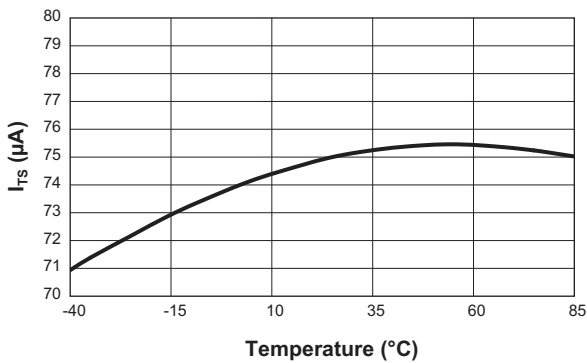

Shutdown Current vs. Input Voltage

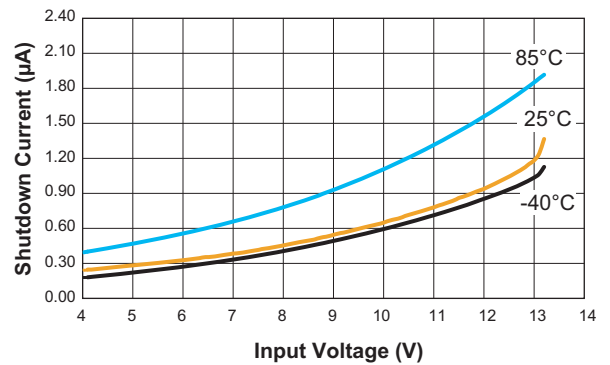

Charging Transistor On Resistance vs. Input Voltage

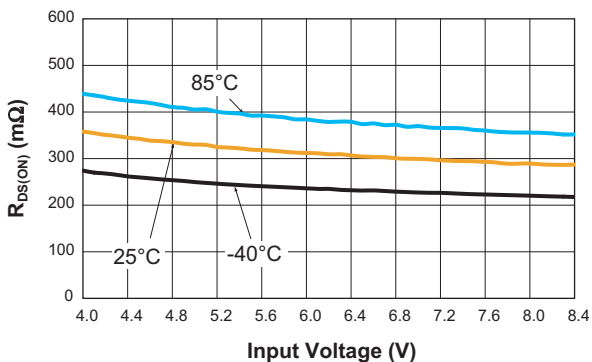

CT Pin Capacitance vs. Counter Timeout

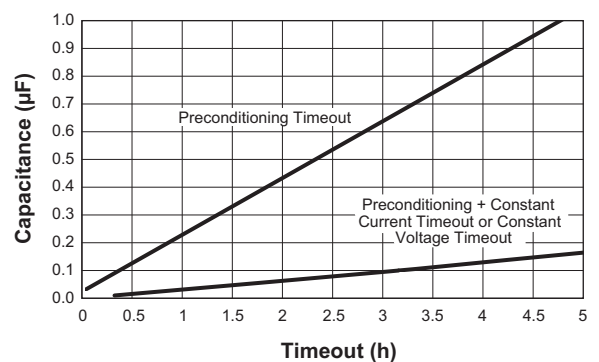

1A Linear Li-Ion Battery Charger for Single and Dual Cell Applications

Temperature Sense Too Hot Threshold Voltage vs. Temperature

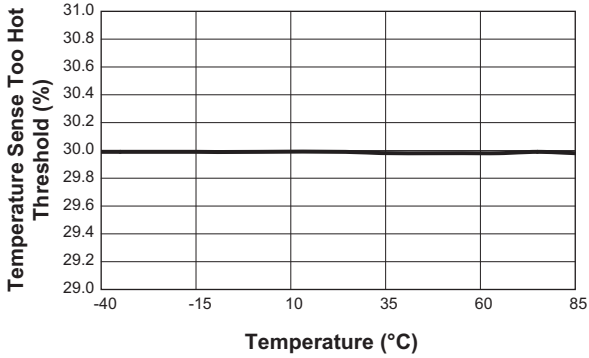

Temperature Sense Too Cold Threshold Voltage vs. Temperature

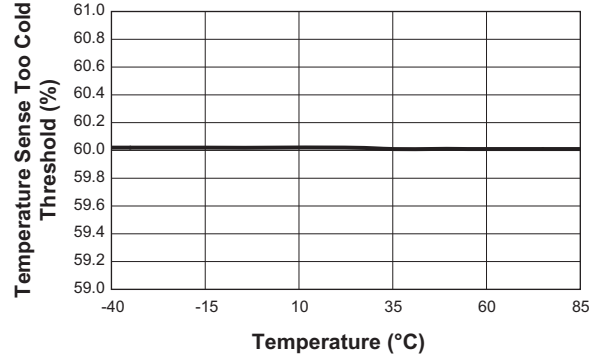

Input High Threshold vs. Input Voltage

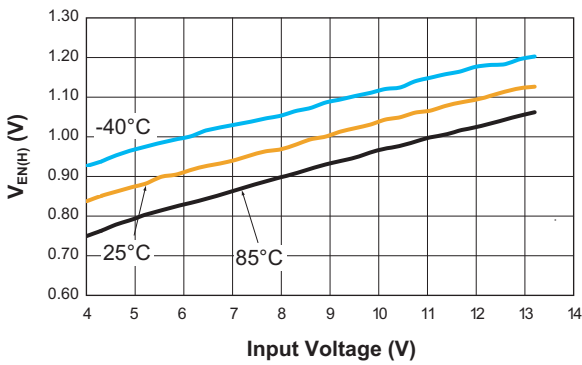

Input Low Threshold vs. Input Voltage

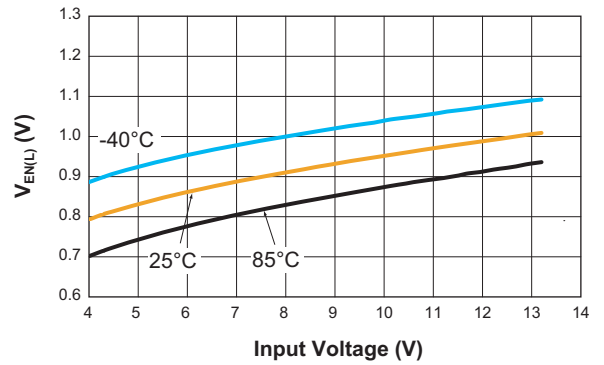

Termination Current to Constant Current Ratio (%) vs. Termination Resistance

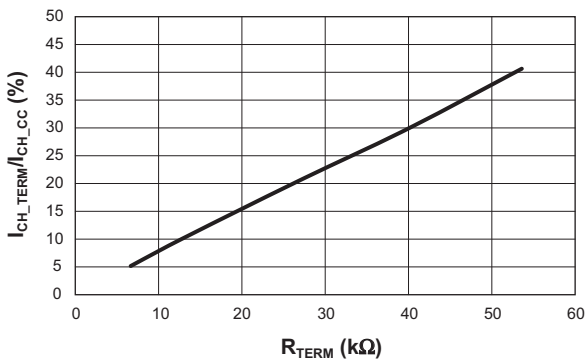

1A Linear Li-Ion Battery Charger for Single and Dual Cell Applications

Typical Characteristics—Single Cell 4.2V

End of Charge Voltage Accuracy vs. Input Voltage
($V_{BAT_EOC} = 4.2V$)

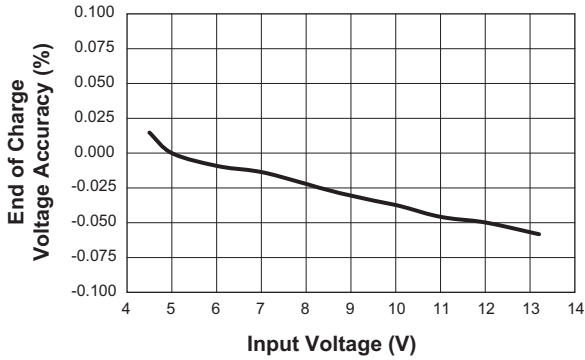

End of Charge Voltage vs. Temperature

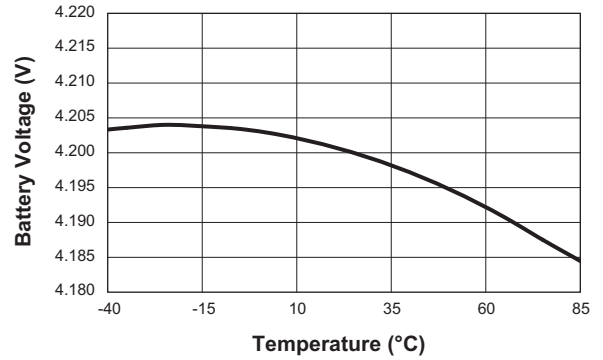

Recharge Threshold Voltage vs. Input Voltage

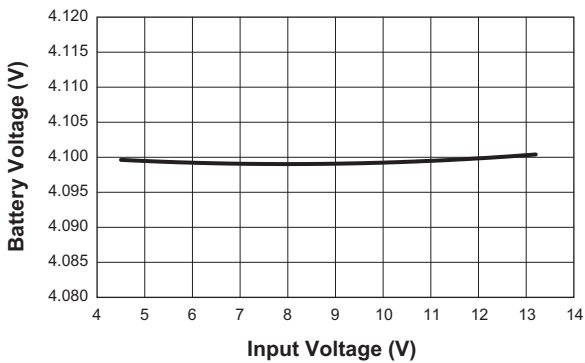

Recharge Voltage vs. Temperature
($V_{IN} = 5V$; $R_{SET} = 8.87k\Omega$)

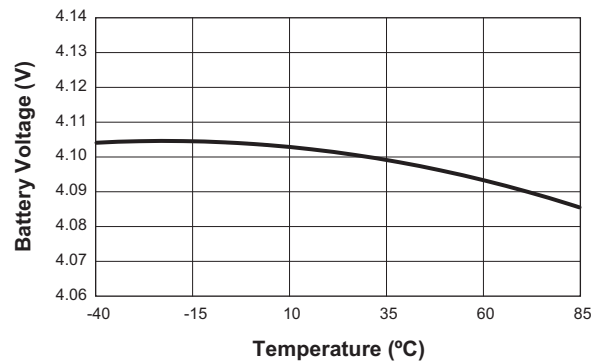

Charging Current vs. Battery Voltage
($R_{SET} = 8.87k\Omega$)

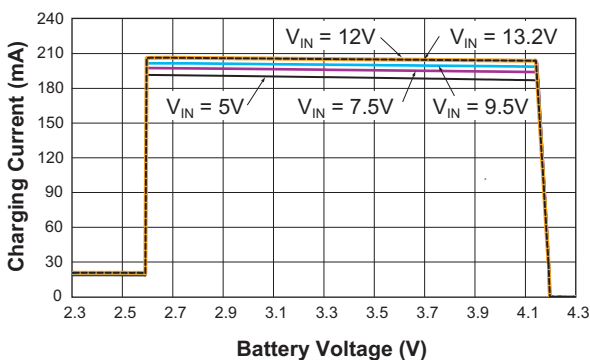

Charging Current vs. Battery Voltage

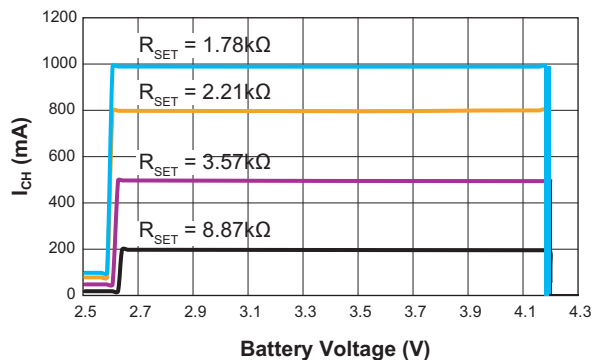

1A Linear Li-Ion Battery Charger for Single and Dual Cell Applications

Typical Characteristics—Single Cell 4.2V

Preconditioning Threshold Voltage vs. Input Voltage

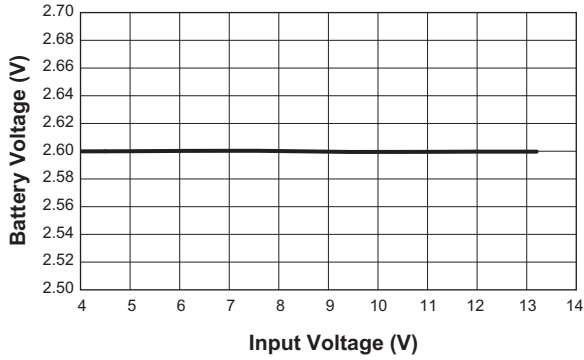

Preconditioning Threshold Voltage vs. Temperature

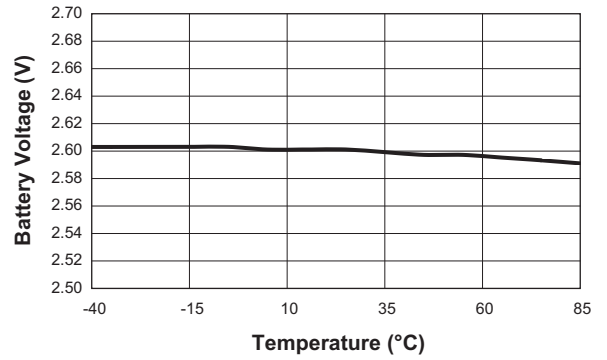

Preconditioning Charge Current vs. Input Voltage

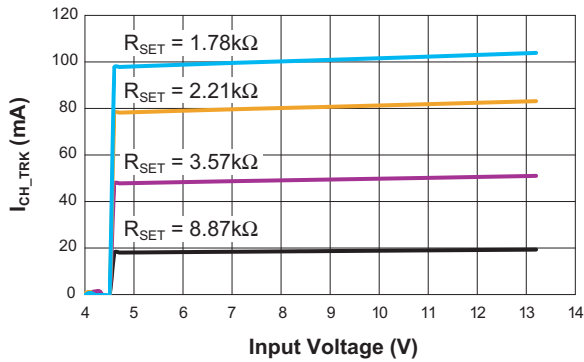

Constant Charge Current vs. Input Voltage ($R_{SET} = 8.87k\Omega$)

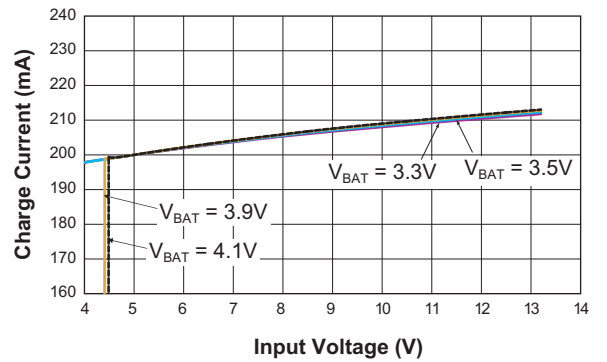

1A Linear Li-Ion Battery Charger for Single and Dual Cell Applications

Typical Characteristics—Dual Cell 8.4V

End of Charge Voltage Accuracy vs. Input Voltage
 ($V_{BAT_EOC} = 8.4V$)

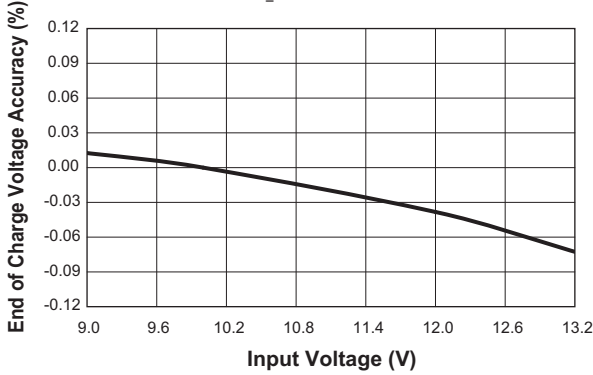

End of Charge Voltage vs. Temperature
 ($V_{IN} = 10V$; $R_{SET} = 8.87k\Omega$)

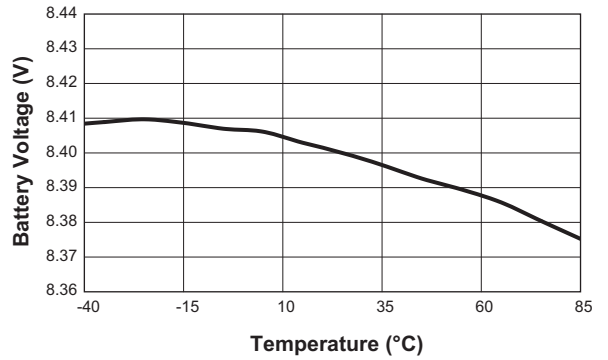

End of Charge Voltage vs. Input Voltage
 ($R_{SET} = 8.87k\Omega$)

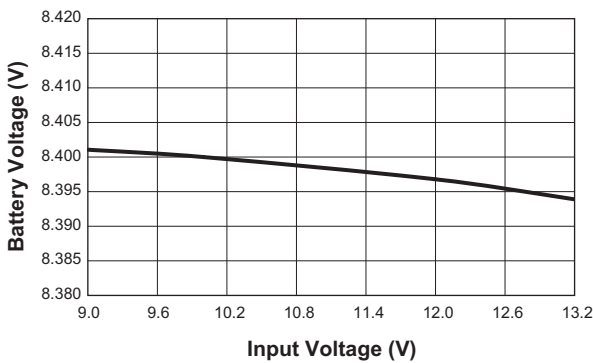

Recharge Threshold Voltage vs. Input Voltage

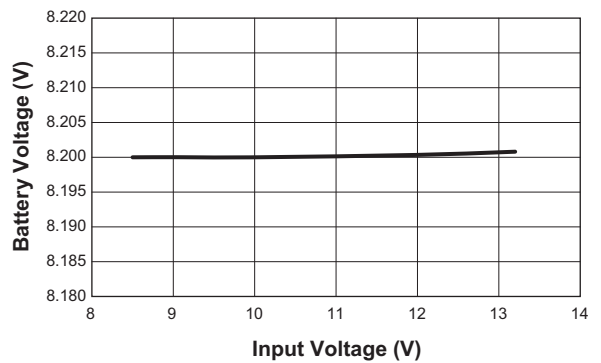

Recharge Threshold Voltage vs. Temperature
 ($V_{IN} = 10V$; $R_{SET} = 8.87K\Omega$)

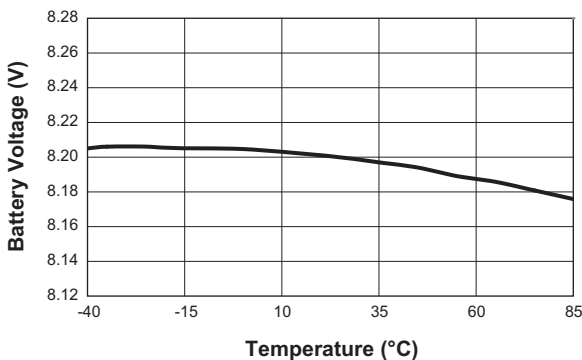

Constant Charging Current vs. Battery Voltage
 ($R_{SET} = 8.87K\Omega$)

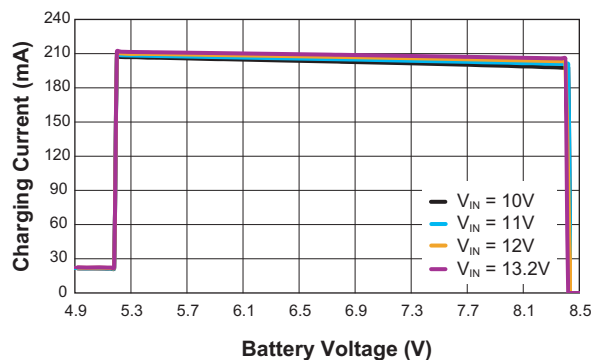

1A Linear Li-Ion Battery Charger for Single and Dual Cell Applications

Typical Characteristics—Dual Cell 8.4V

Constant Charging Current vs. Battery Voltage

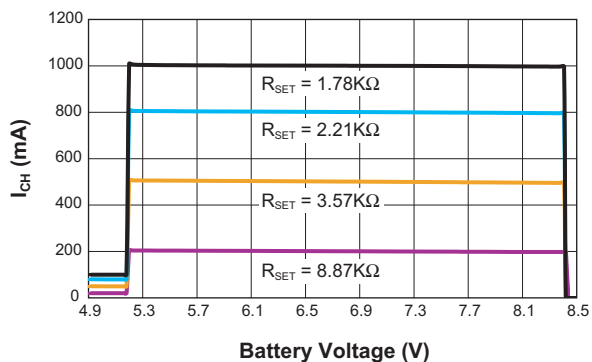

Preconditioning Threshold Voltage vs. Input Voltage

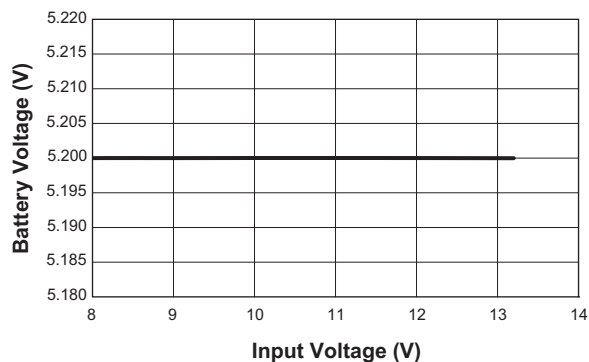

Preconditioning Threshold Voltage vs. Temperature

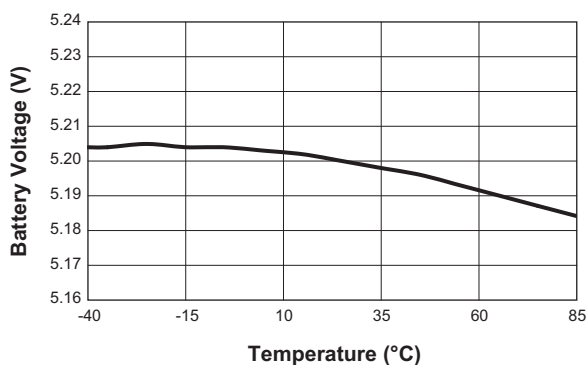

Constant Charge Current vs. Input Voltage
($R_{SET} = 8.87K\Omega$)

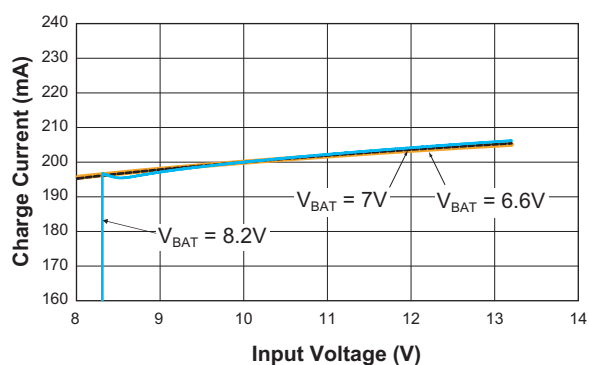

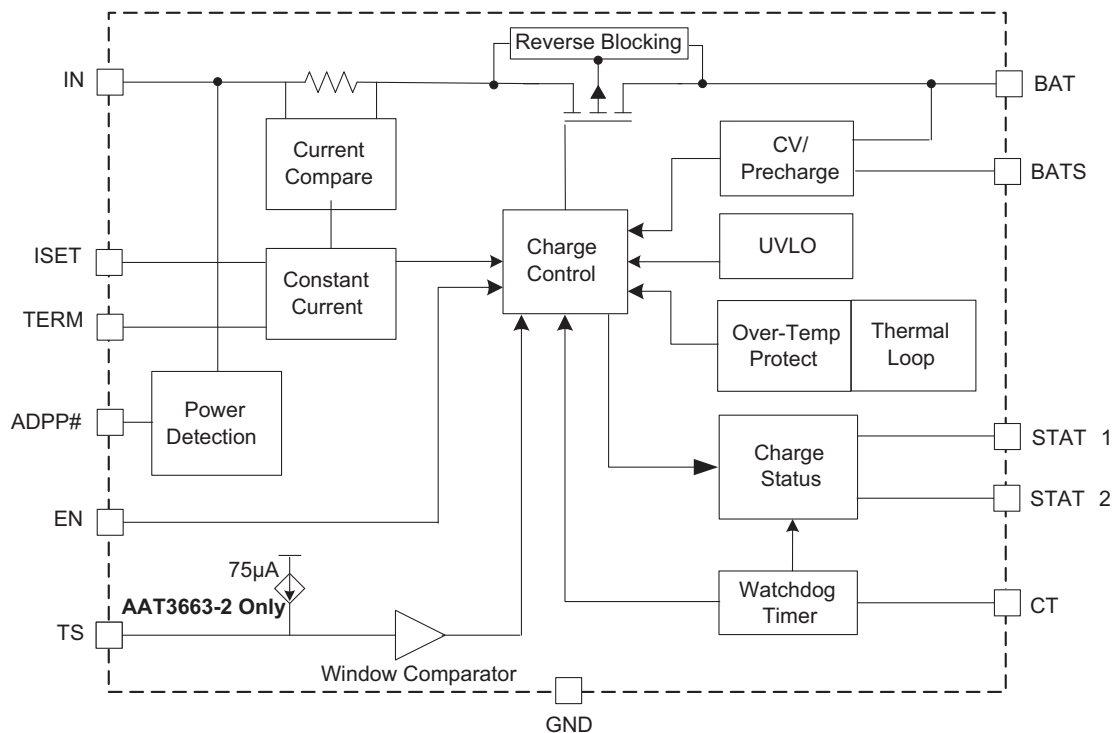
1A Linear Li-Ion Battery Charger for Single and Dual Cell Applications**Functional Block Diagram****Functional Description**

The AAT3663 is a high performance battery charger designed to charge single/dual cell Lithium-Ion or Lithium-Polymer batteries with up to 1000mA of current from an external power source. It is a highly integrated stand-alone charging solution, with the least external components required for complete functionality.

The AAT3663 precisely regulates end of charge battery voltage and current for single cell 4.2V and dual cell 8.4V lithium-ion/polymer battery with a programmable constant current range from 100mA to 1A for fast charging applications. The system has a default charge termination current set to 10 percent of the programmed fast charge constant. The charge termination current may also be user programmed by an external resistor.

During battery charging, the device temperature will rise. In some cases with adapter (ADP) charging, the power dissipation in the charge regulation pass device may cause the junction temperature to rise and approach the internal thermal shutdown threshold. Excessive power dissipation is caused by the high input adapter voltage versus the low output battery cell voltage difference at a given constant charge current. In the event of an internal

over-temperature condition caused by excessive ambient operating temperature or excessive power dissipation conditions, the AAT3663 enables a digitally controlled thermal loop system that will reduce the charging current to prevent thermal shutdown. The digital thermal loop will maintain the maximum possible battery charging current for a given set of input to output power dissipation and ambient temperature conditions.

The digital thermal loop control is dynamic in the sense that it will continue to adjust the battery charging current as operating conditions change. The digital thermal loop will reset and resume normal operation when the power dissipation or over-temperature conditions are removed.

In the event of an over-voltage, over-current or over-temperature false condition beyond the limits of the digital thermal loop system, the device will automatically shut down, thus protecting the charging device, control system, and the battery under charge.

AAT3663 provides two status monitor pins, STAT1 and STAT2. These pins are open drain MOSFET switches intended to directly drive external LEDs to indicate the battery charging state. A third status pin is provided to indicate the presence of power on the input supply pin.

1A Linear Li-Ion Battery Charger for Single and Dual Cell Applications

This open drain MOSFET switch may be used to either power a display LED or to alert a system microcontroller for the presence on input power.

Battery Charging Operation

Figure 1 illustrates the entire battery charging profile and operation, which consists of three phases:

1. Preconditioning (Trickle) Charge
2. Constant Current Charge
3. Constant Voltage Charge

When power is initially applied or when a battery pack is connected to the BAT pin, battery charging commences after the AAT3663 checks several conditions in order to maintain a safe charging environment. The input supply must be above the minimum operating voltage (UVLO) and the enable pin must be high (internally pulled down). When the battery is connected to the BAT pin the AAT3663 checks the condition of the battery and determines which charging mode to apply.

Battery Preconditioning

If the battery voltage is below V_{MIN} , the AAT3663 begins battery trickle charging by charging at 10% of the programmed constant-current. For example, if the programmed current is 500mA, then the trickle charge current is 50mA. Trickle charging is a recommended safety precaution for a deeply discharged cell and maximizes the charge cycle life of the battery. In addition, charger IC power dissipation for the internal series pass MOSFET is minimized when the input-output voltage differential is at its highest. This in turn allows the charging operation to commence over wider thermal and input to output voltage differential conditions.

Constant Current Charging

Trickle charging continues until the battery voltage reaches the V_{MIN} threshold. At this point, the AAT3663 begins constant-current fast charging. The current level for this mode is programmed using a single resistor from the ISET pin to ground. Programmed current can be set at a minimum 100mA up to a maximum 1A.

Constant Voltage Charging

Constant current charging continues until such time that the battery voltage reaches the voltage regulation point V_{BAT_REG} . When the battery voltage reaches V_{BAT_REG} , the AAT3663 will transition to the constant-voltage mode. The regulation voltage is factory programmed to a nominal 4.2V for the AAT3663-4.2 option and to 8.4V for the AAT3663-8.4 option. Under default conditions with the TERM pin not connected (open circuit), constant voltage charging will continue until the charge current has reduced to 10% of the programmed current. Placing a resistor between the TERM pin and ground allows the user to program a desired termination current.

After the charge cycle is complete, the AAT3663 turns off the series pass device and automatically goes into a power saving sleep mode. During this time the series pass device will block current in both directions therefore preventing the battery discharging through the IC.

The AAT3663 will remain in sleep mode, until either the battery terminal voltage drops below the V_{RCH} threshold, the charger EN pin is recycled or the charging power source is reconnected. In all cases the AAT3663 will monitor all battery parameters and resume charging in the appropriate mode.

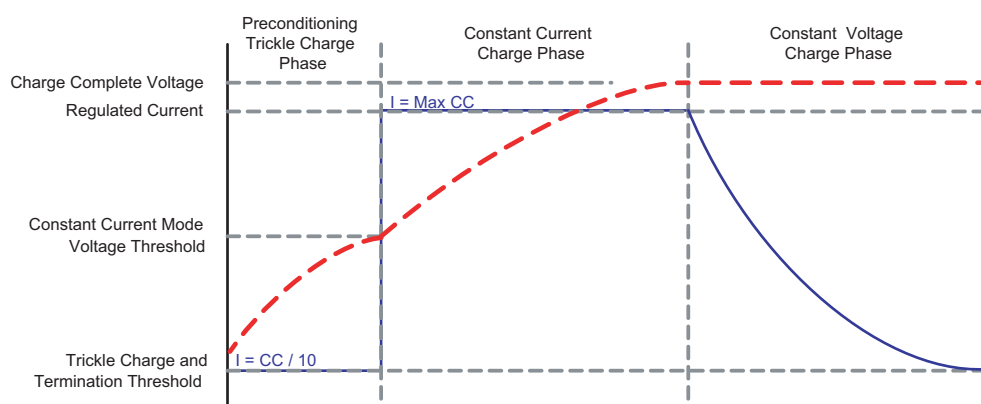
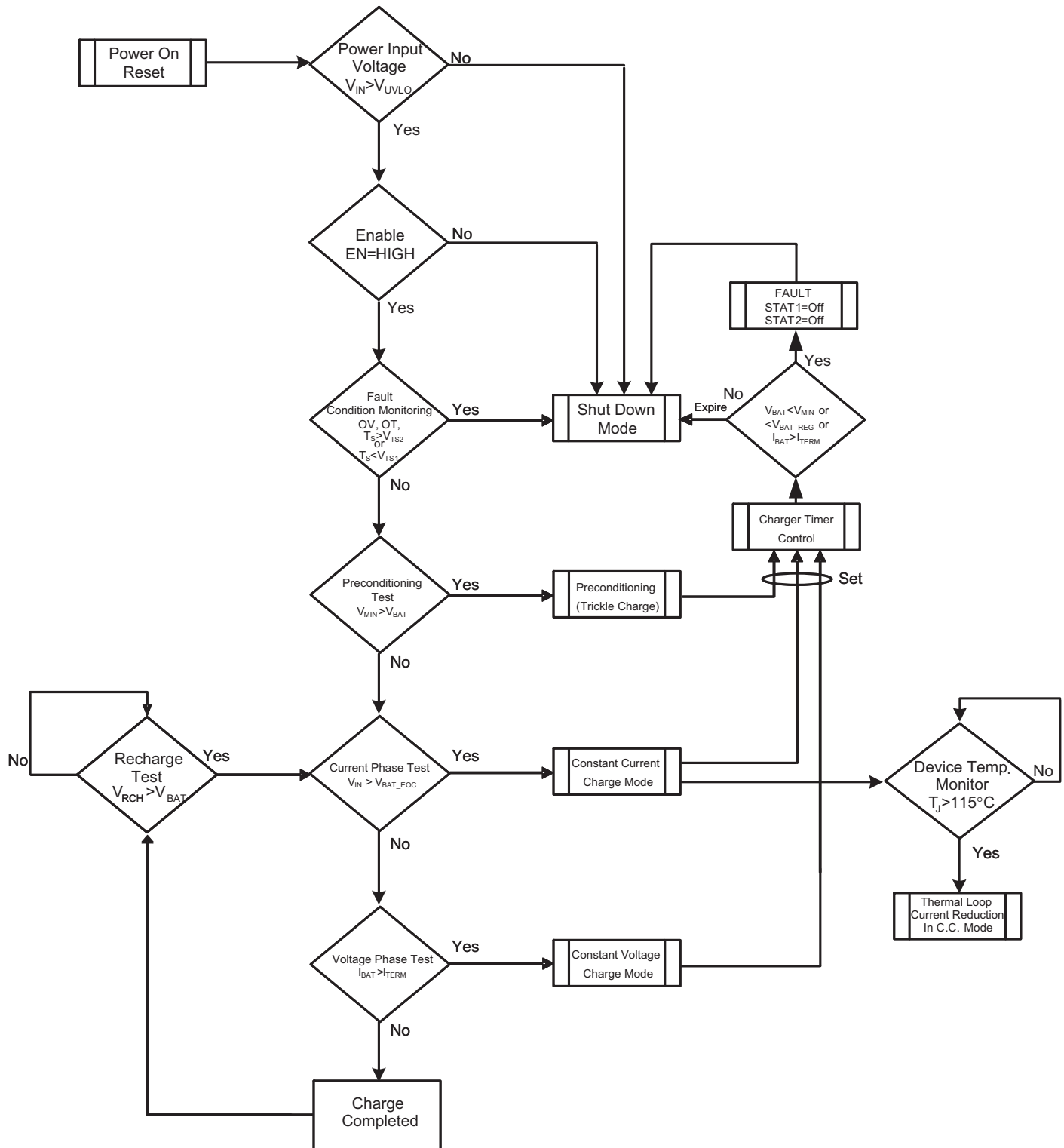

Figure 1: Current and Voltage Profile During Charging Phases.

1A Linear Li-Ion Battery Charger for Single and Dual Cell Applications

System Operation Flow Chart



1A Linear Li-Ion Battery Charger for Single and Dual Cell Applications

Application Information

Adapter or USB Power Input

Constant current charge levels up to 1A may be programmed by the user when powered from a sufficient input power source. The AAT3663 will operate over an input voltage range from 4.0V to 13.2V. The low input voltage capability of the AAT3663 permits charging single cell Li-Ion/Poly batteries from USB ports and lower voltage input power sources. The high 13.2V input rating of this device allows for the use of a wide range of input power sources for both single and dual cell Li-Ion/Poly applications.

Adapter Input Charge Inhibit and Resume

The AAT3663 has an under-voltage lockout (UVLO) and power on reset feature so that if the input supply to the IN pin drops below the UVLO threshold, the charger will suspend charging and shut down. When power is reapplied to the IN pin or the UVLO condition recovers, the system charge control will assess the state of charge on the battery cell and will automatically resume charging in the appropriate mode for the condition of the battery.

Battery Connection and Battery Voltage Sensing

Battery Connection

A single or dual cell Li-Ion/Polymer battery should be connected between the BAT pin and ground.

Battery Voltage Sensing

The BATS pin is provided to employ an accurate voltage sensing capability to measure the positive terminal voltage at the battery cell being charged. This function reduces measured battery cell voltage error between the battery terminal and the charge control IC. The AAT3663 charge control circuit will base charging mode states upon the voltage sensed at the BATS pin. The BATS pin must be connected to the battery terminal for correct operation. If the battery voltage sense function is not needed, the BATS pin should be terminated directly to the BAT pin. If there is concern of the battery sense function inadvertently becoming an open circuit, the BATS pin may be terminated to the BAT pin using a 10kΩ resistor. Under normal operation, the connection to the battery terminal will be close to 0Ω; if the BATS connection becomes an open circuit, the 10kΩ resistor will pro-

vide feedback to the BATS pin from the BAT connection with a voltage sensing accuracy loss of 1mV or less.

Enable (EN)

EN is a logic input (active high) to enable the charger, this function is internally pulled down to ground. When the device is initially enabled or if the EN pin is cycled low and then re-enabled, the charge control circuit will automatically reset and resume charging functions with the appropriate charging mode based on the battery charge state and measured battery voltage on the BATS pin.

Programming Charge Current

The constant current mode charge level is user programmed with a set resistor (R_{SET}) connected between the ISET pin and ground. The accuracy of the constant charge current, as well as the preconditioning trickle charge current, is dominated by the tolerance of the set resistor used. For this reason, a 1% tolerance metal film resistor is recommended for the set resistor function. The constant charge current levels from 100mA to 1A may be set by selecting the appropriate resistor value from Table 1.

Constant Charging Current (mA)	Set Resistor Value (kΩ)
100	17.8
200	8.87
300	5.9
400	4.42
500	3.57
600	2.94
700	2.55
800	2.21
900	1.96
1000	1.78

Table 1: R_{SET} Values.

If the desired charge current level is not listed in Table 1, the R_{SET} resistor value can be found in Figure 2 and calculated by the following equation:

$$R_{SET} = K \cdot \left(\frac{V_{ISET}}{I_{CC}} \right)$$

Where:

$$K = K_{I_{SET}} = 900$$

$$V_{ISET} = 2V$$

$$I_{CC} = \text{Fast charge constant current}$$

1A Linear Li-Ion Battery Charger for Single and Dual Cell Applications

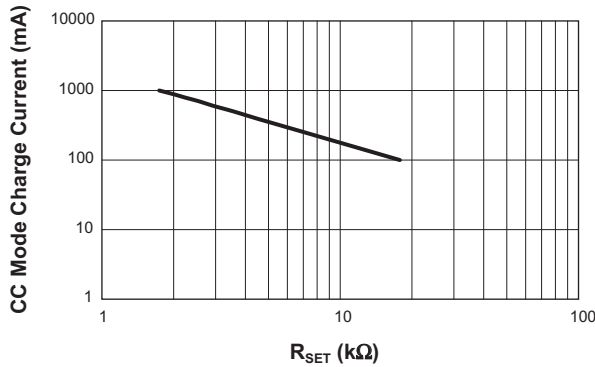

Figure 2: Constant Charging Current vs. R_{SET} Resistor Values.

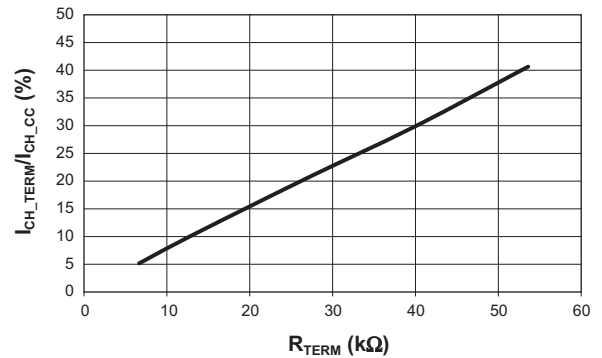

Figure 3: Charge Termination Current (% Value of the Programmed Fast Charge Current) vs. R_{TERM} Resistance.

Programmable Charge Termination Current

The AAT3663 is designed with a default charge termination current set to 10 percent of the programmed fast charge constant current level. The charge termination current (I_{CH_TERM}) may also be user programmed to a level other than 10% of the set fast charge current by connecting a set resistor (R_{TERM}) between the TERM pin and ground.

When the charge current under the constant voltage charging mode drops to the charge termination threshold the device halts charging and goes into a sleep mode. The charger will remain in the sleep mode until the battery voltage as sensed by the BATS pin decreases to a level below the battery recharge voltage threshold (V_{RCH}). Charge termination current levels based on a percentage of the programmed fast charge current are shown in Figure 3.

If the desired charge termination current set resistor (R_{TERM}) value is not shown in Figure 3, the value may be determined by the following equation:

$$I_{CH_TERM} = \frac{15\mu A \cdot R_{TERM}}{2V} \cdot I_{CH_CC}$$

Where:

- I_{CH_TERM} = Charge termination current level
- I_{CH_CC} = Programmed fast charge constant current level
- R_{TERM} = TERM resistor value

Battery Charge Status Indication

The AAT3663 indicates the status of the battery under charge using three status LED driver outputs. These three LEDs can indicate simple functions such as input power present, no battery charge activity, battery charging, charge complete and charge fault.

Status Indicator Display

System charging status may be displayed using one or two LEDs in conjunction with the STAT1 and STAT2 pins on the AAT3663. These two pins are simple open drain N-channel MOSFET switches to connect the status LED cathodes to ground. It is not necessary to use both display LEDs if a user simply wants to have a single LED to show "charging" or "not charging". This can be accomplished by just using the STAT1 pin and a single LED. Using two LEDs and both STAT pins simply gives the user more information for the various charging states. Refer to Table 2 for LED display definitions.

Event Description	STAT1	STAT2
Charge enabled without battery	Flash ¹	Flash ¹
Battery charging	ON	OFF
Charging completed	OFF	ON
Fault	OFF	OFF

Table 2: LED Status Indicator Truth Table.

1. Flashing rate depends on output capacitance.

1A Linear Li-Ion Battery Charger for Single and Dual Cell Applications

The LED anodes should be connected to the charger power source input (IN pin).

Input Power Present Indicator

The ADDP# pin provides an additional open drain N-channel MOSFET switch to indicate the presence of power applied to the charger input (IN pin). This function may either be used to control an addition status LED to give a visual indication when input power is applied. This open drain output may also be pulled high via a pull up resistor to provide an active low signal to a system microcontroller to indicate the presence of applied input power.

Status Display LED Biasing

The LED should be biased with as little current as necessary to create reasonable illumination; therefore, a ballast resistor should be placed between the LED cathode and the STAT pin. LED current consumption will add to the overall thermal power budget for the device package, hence it is good to keep the LED drive current to a minimum. 2mA should be sufficient to drive most low-cost green or red LEDs. It is not recommended to exceed 8mA for driving an individual status LED.

The required ballast resistor values can be estimated using the following formula:

$$R_{\text{BALLAST}} = \frac{(V_{\text{IN}} - V_{\text{F(LED)}})}{I_{\text{LED}}}$$

Example:

$$R_{\text{BALLAST}} = \frac{(5.0\text{V} - 2.0\text{V})}{2\text{mA}} = 1.5\text{k}\Omega$$

Note: Red LED forward voltage (V_{F}) is typically 2.0V @ 2mA.

Digital Thermal Loop Control

Due to the integrated nature of the linear charging control pass device for the adapter mode, a special thermal loop control system has been employed to maximize charging current under all operation conditions. The thermal management system measures the internal circuit die temperature and reduces the fast charge current when the device exceeds a preset internal temperature control threshold. Once the thermal loop control becomes active, the fast charge current is initially reduced by a

factor of 0.28. The initial thermal loop current can be estimated by the following equation:

$$I_{\text{TLOOP}} = I_{\text{CH_CC}} \cdot 0.28$$

The thermal loop control re-evaluates the circuit die temperature every 1.5 seconds and adjusts the fast charge current back up in small steps to the full fast charge current level or until an equilibrium current is discovered and maximized for the given ambient temperature condition. The thermal loop controls the system charge level; therefore, the AAT3663 will always provide the highest level of constant current in the fast charge mode possible for any given ambient temperature condition.

Protection Circuitry**Programmable Timer Function**

The AAT3663 contains a watchdog timing circuit to shut down charging functions in the event of a defective battery cell not accepting a charge over a preset period of time. Typically, a 0.1 μ F ceramic capacitor is connected between the CT pin and ground. When a 0.1 μ F ceramic capacitor is used, the device will time out a shutdown condition if the trickle charge mode exceeds 25 minutes and a combined trickle charge plus constant current mode of 3 hours. When the device transitions to the constant voltage mode, the timing counter is reset and will time out after an additional 3 hours if the charge current does not drop to the charge termination level.

The AAT3663 has a battery fault detector, which, when used in conjunction with a 0.1 μ F capacitor on the CT pin, outputs a 1Hz signal with 50% duty cycle at the STAT1 pin in the event of a timeout while in the trickle charge mode.

Mode	Time
Trickle Charge (TC) Time Out	25 minutes
Trickle Charge (TC) + Constant Current (CC) Mode Time Out	3 hours
Constant Voltage (CV) Mode Time Out	3 hours

Table 3: Summary for a 0.1 μ F Ceramic Capacitor Used for the Timing Capacitor.

The CT pin is driven by a constant current source and will provide a linear response to increases in the timing capacitor value. Thus, if the timing capacitor were to be doubled from the nominal 0.1 μ F value, the timeout periods would be doubled. If the programmable watchdog

1A Linear Li-Ion Battery Charger for Single and Dual Cell Applications

timer function is not needed, it can be disabled by terminating the CT pin to ground. The CT pin should not be left floating or unterminated, as this will cause errors in the internal timing control circuit. The constant current provided to charge the timing capacitor is very small, and this pin is susceptible to noise and changes in capacitance value. Therefore, the timing capacitor should be physically located on the printed circuit board layout as close as possible to the CT pin. Since the accuracy of the internal timer is dominated by the capacitance value, a 10% tolerance or better ceramic capacitor is recommended. Ceramic capacitor materials, such as X7R and X5R types, are a good choice for this application.

Over-Voltage Protection

An over-voltage event is defined as a condition where the voltage on the BAT pin exceeds the maximum battery charge voltage and is set by the overvoltage protection threshold (V_{OVP}). If an over-voltage condition occurs, the AAT3663 charge control will shut down the device until the voltage on the BAT pin drops below V_{OVP} . The AAT3663 will resume normal charging operation after the overvoltage condition is removed. During an over-voltage event, the STAT LEDs will report a system fault.

Over-Temperature Shutdown

The AAT3663 has a thermal protection control circuit which will shut down charging functions once the internal die temperature exceeds the over-temperature shutdown threshold. Once the internal die temperature falls below the hysteresis, normal operation will resume the previous charging state.

Battery Temperature Fault Monitoring

There are two AAT3663 temperature sense options, The AAT3663-1 and AAT3663-2. The AAT3663-1 option allows of the use of any NTC resistor. For ease of use, the AAT3663-2 option is factory set to function with typical 10k Ω NTC resistors and eliminates the need for a resistor divider pull up to the input power source.

Regardless of the AAT3663 option selected, the internal system control checks battery temperature before starting the charge cycle and continues to monitor the battery temperature during all stages of the charging cycle. This is accomplished by monitoring the voltage at the TS pin. In general, the system is intended for use with negative temperature coefficient thermistors (NTC)

which are typically integrated into the battery package. The voltage on the TS pin resulting from the resistive load and applied current, should stay within a window bounded by the TS1 and TS2 specification thresholds. Refer to the Electrical Characteristics table for the TS1 and TS2 limits for a selected AAT3663 option. If the battery becomes too hot during charge cycle due to an internal fault or excessive charge current, the NTC thermistor will heat up and reduce in value. This in turn will pull the TS pin voltage below than the TS1 threshold, and indicate a battery cell temperature fault. The charging process will then be suspended until the over-temperature condition is removed, at which time charging will resume. Conversely, if the battery under charge is exposed to extreme cold ambient temperature condition, the NTC thermistor may increase in value and push the voltage on the TS pin above the TS2 threshold. In such a case, the charge cycle will be suspended and will not resume until the cold fault condition is removed. Both TS1 and TS2 temperature fault conditions will be report by the STAT1 and STAT2 LEDs.

AAT3663-1 Option

the AAT3663-1 option utilizes an internal battery temperature sensing system comprised of two comparators which establish a voltage window for safe operation. The thresholds for the TS operating window are bounded by the TS1 and TS2 specifications. Referring to the electrical characteristics table in this datasheet, the TS1 threshold = $0.30 \cdot V_{IN}$ and the TS2 threshold = $0.6 \cdot V_{IN}$. Refer to Figure 4 for external resistor and NTC thermistor connections.

If the use of the battery temperature sense function is not required, it may be disabled by terminating the TS pin to IN and ground using a 10k Ω resistor divider network. If circuit power dissipation is a concern, the two terminating resistor values may be increased to 100k Ω .

AAT3663-2 Option

Most of the commonly used NTC thermistors in Li-Ion/ Polymer battery packs are approximately 10k Ω at room temperature (25 $^{\circ}$ C). The AAT3663-2 TS pin has been specifically designed to source 75 μ A of current to the 10k Ω NTC thermistor. The applied constant current source and fixed internal TS1 and TS2 voltage thresholds eliminate the need for a resistor divider on the TS pin. Simply connect the 10k Ω NTC resistor between the TS pin and ground. If the TS function is not needed for the AAT3663-2, it may be left open (not connected).

IA Linear Li-Ion Battery Charger for Single and Dual Cell Applications

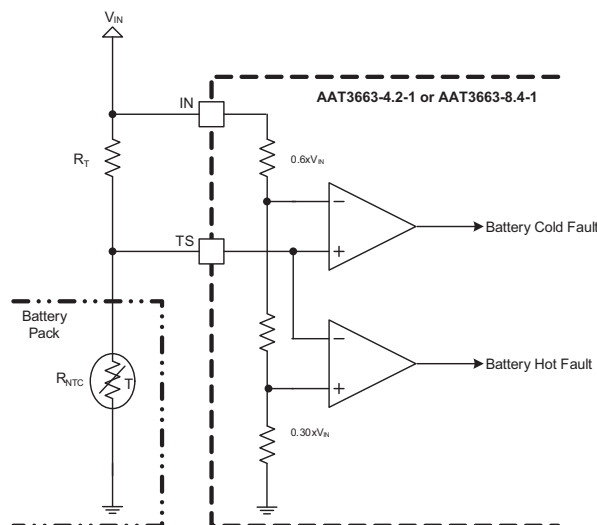

Figure 4: External Resistor and NTC Thermistor Application Circuit.

Thermal Considerations

The AAT3663 is offered in a 3x3mm TDFN package which can provide up to 2.0W of power dissipation when it is properly bonded to a printed circuit board and has a maximum thermal resistance of 50°C/W. Many considerations should be taken into account when designing the printed circuit board layout, as well as the placement of the charger IC package in proximity to other heat generating devices in a given application. The ambient temperature around the charger IC will also have an effect on the thermal limits of the battery charging operation. The maximum limits that can be expected for a given ambient condition can be estimated by the following discussion.

First, the maximum power dissipation for a given situation should be calculated:

$$P_{D(MAX)} = \frac{(T_J - T_A)}{\theta_{JA}}$$

Where:

- $P_{D(MAX)}$ = Maximum Power Dissipation (W)
- θ_{JA} = Package Thermal Resistance (°C/W)
- T_J = Thermal Loop Entering Threshold (°C) [115°C]
- T_A = Ambient Temperature (°C)

Figure 5 shows the relationship between maximum power dissipation and ambient temperature of AAT3663

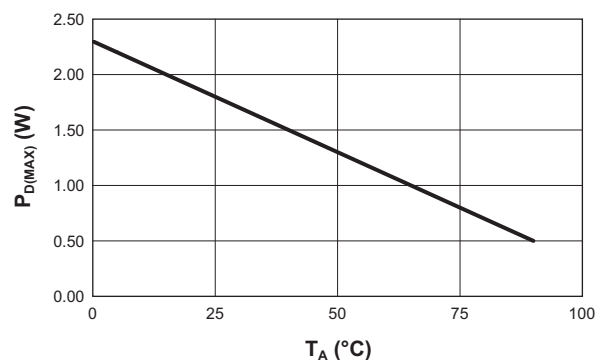

Figure 5: Maximum Power Dissipation Before Entering Thermal Loop.

Next, the power dissipation can be calculated by the following equation:

$$I_{CH(MAX)} = \frac{(P_{D(MAX)} - V_{IN} \cdot I_{OP})}{V_{IN} - V_{BAT}}$$

$$I_{CH(MAX)} = \frac{(T_J - T_A) - V_{IN} \cdot I_{OP}}{\theta_{JA} (V_{IN} - V_{BAT})}$$

Where:

- P_D = Total Power Dissipation by the Device
- V_{IN} = Input Voltage
- V_{BAT} = Battery Voltage as Seen at the BAT Pin
- I_{CH} = Constant Charge Current Programmed for the Application

1A Linear Li-Ion Battery Charger for Single and Dual Cell Applications

I_{OP} = Quiescent Current Consumed by the Charger IC for Normal Operation [0.5mA]

By substitution, we can derive the maximum charge current before reaching the thermal limit condition which will activate digital thermal loop operation. The maximum charge current is the key factor when designing battery charger applications.

In general, the worst case condition is when the greatest input to output voltage drop occurs across the charger IC. Specifically when battery voltage is charged up just above the preconditioning voltage threshold and the charger enters into the constant current fast charging mode. Under this condition, the device will suffer the maximum possible power dissipation since both the voltage difference across the device and the charge current will be at their respective maximums. Figure 6 shows the safe fast charge current operating region for different ambient temperatures. Exceeding these limits will drive the charge control into digital thermal loop operation. When under digital thermal loop operation, the device will remain active and continue to charge the battery at a reduced current level for the given ambient condition.

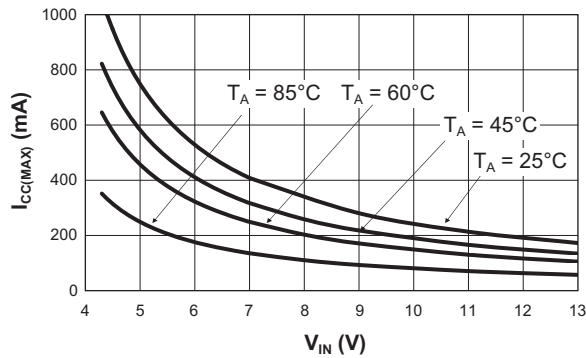

Figure 6: Maximum Charging Current Before the Digital Thermal Loop Becomes Active.

Capacitor Selection

Input Capacitor

In general, it is a good design practice to place a decoupling capacitor between the IN pin and ground. An input capacitor in the range of 1 μ F to 22 μ F is recommended. If the source supply is unregulated, it may be necessary to increase the capacitance to keep the input voltage above the under-voltage lockout threshold during device enable and when battery charging is initiated. If the AAT3663's input is to be used in a system with an external power supply source, such as a typical AC-to-DC wall adapter, then a C_{IN} capacitor in the range of 10 μ F should be used. A larger input capacitor in this application will minimize switching or power transient effects when the power supply is "hot plugged" in.

Output Capacitor

The AAT3663 only requires a 1 μ F ceramic capacitor on the BAT pin to maintain circuit stability. This value should be increased to 10 μ F or more if the battery connection is made any distance from the charger output. If the AAT3663 is to be used in applications where the battery can be removed from the charger, such as desktop charging cradles, an output capacitor 10 μ F or greater is recommended to reduce the effect of the charger cycling on and off when no battery is present.

Printed Circuit Board Layout Considerations

For the best results, it is recommended to physically place the battery pack as close as possible to the AAT3663 BAT pin. To minimize voltage drops on the PCB, keep the high current carrying traces adequately wide. For maximum power dissipation of the AAT3663 3 \times 3mm 14-pin TDFN package, the metal substrate should be solder bonded to the board. It is also recommended to maximize the substrate contact to the PCB ground plane layer to further increase local heat dissipation. Refer to the AAT3663 evaluation board for a good layout example.

AAT3663

1A Linear Li-Ion Battery Charger for Single and Dual Cell Applications

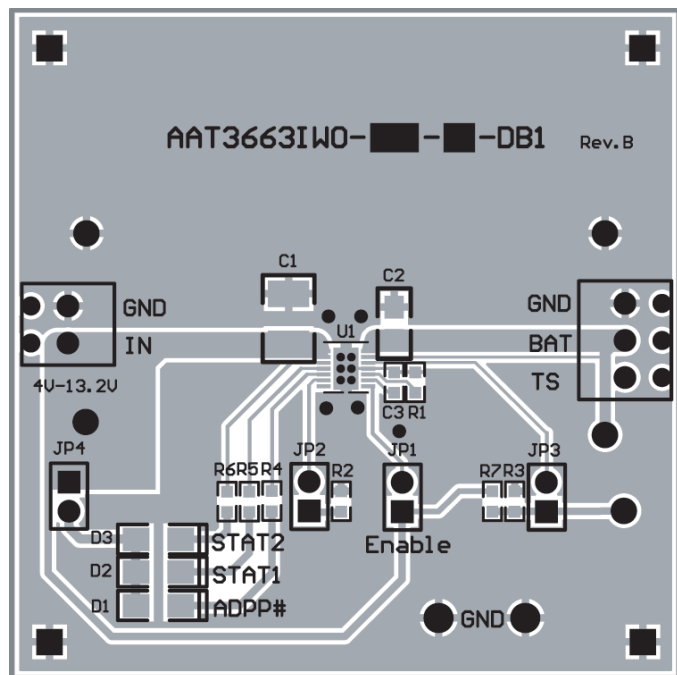

Figure 7: AAT3663 Evaluation Board Top (Component) Side Layout.

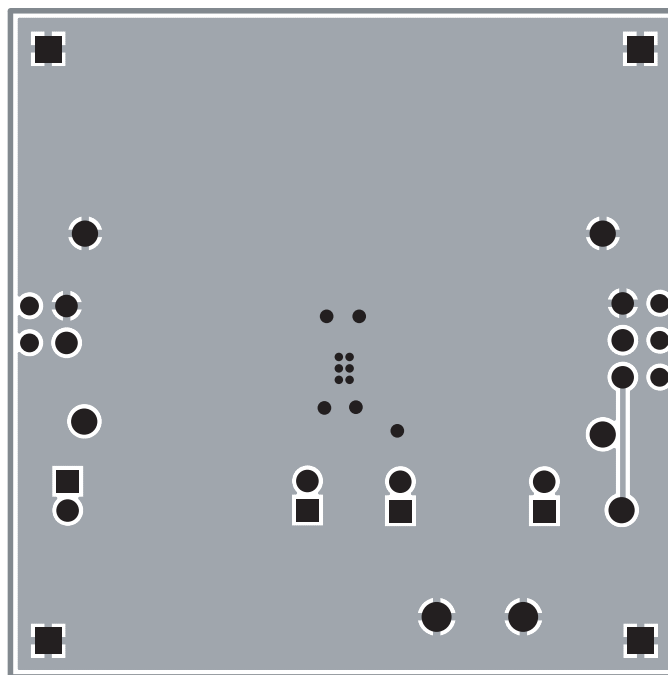
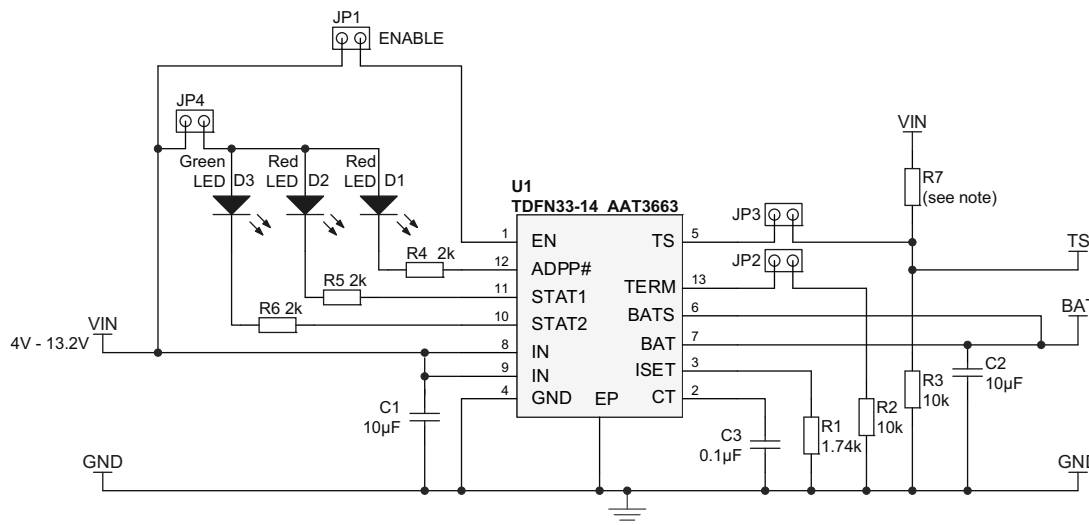

Figure 8: AAT3663 Evaluation Board Bottom Side Layout.



C1 1206 X7R 10µF 16V GRM31CR71C106KAC7L
 C2 0805 X7R 10µF 10V GRM21BR71A106KE51L

Note: R2 = 10k is set the termination current, 7.5% from the constant charging current
 R7 = 10k (for -1 option) R7 = open (for -2 option)

Figure 9: AAT3663 Evaluation Board Schematic Diagram.

*1A Linear Li-Ion Battery Charger for Single and Dual Cell Applications***Ordering Information**

Battery Cell Voltage Option	Battery Temperature Sense	Package	Marking ¹	Part Number (Tape and Reel) ²
Single Cell (4.2V)	For Use With Any NTC Thermistor	TDFN33-14	1XXYY	AAT3663IWO-4.2-1-T1
Single Cell (4.2V)	For Use With 10kΩ NTC Thermistor	TDFN33-14	ZZXYY	AAT3663IWO-4.2-2-T1
Dual Cell (8.4V)	For Use With Any NTC Thermistor	TDFN33-14	1YXYY	AAT3663IWO-8.4-1-T1
Dual Cell (8.4V)	For Use With 10kΩ NTC Thermistor	TDFN33-14	1ZXYY	AAT3663IWO-8.4-2-T1



Skyworks Green™ products are compliant with all applicable legislation and are halogen-free.

For additional information, refer to *Skyworks Definition of Green™*, document number SQ04-0074.

1. XYY = assembly and date code.

2. Sample stock is generally held on part numbers listed in **BOLD**.

1A Linear Li-Ion Battery Charger for Single and Dual Cell Applications

Package Information

TDFN33-14

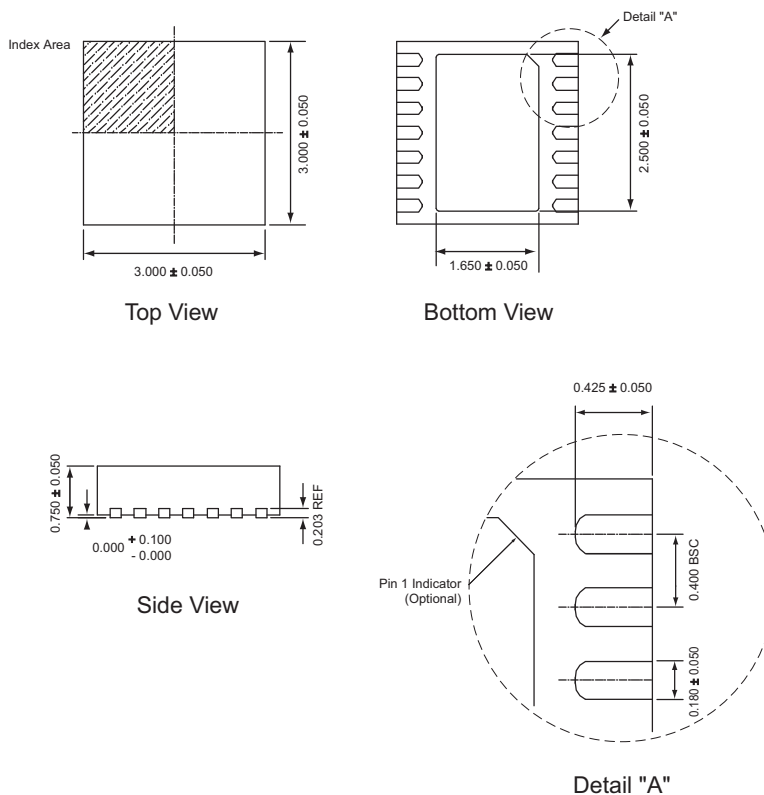

All dimensions in millimeters.

- The leadless package family, which includes QFN, TQFN, DFN, TDFN and STDFN, has exposed copper (unplated) at the end of the lead terminals due to the manufacturing process. A solder fillet at the exposed copper edge cannot be guaranteed and is not required to ensure a proper bottom solder connection.

Copyright © 2012 Skyworks Solutions, Inc. All Rights Reserved.

Information in this document is provided in connection with Skyworks Solutions, Inc. ("Skyworks") products or services. These materials, including the information contained herein, are provided by Skyworks as a service to its customers and may be used for informational purposes only by the customer. Skyworks assumes no responsibility for errors or omissions in these materials or the information contained herein. Skyworks may change its documentation, products, services, specifications or product descriptions at any time, without notice. Skyworks makes no commitment to update the materials or information and shall have no responsibility whatsoever for conflicts, incompatibilities, or other difficulties arising from any future changes.

No license, whether express, implied, by estoppel or otherwise, is granted to any intellectual property rights by this document. Skyworks assumes no liability for any materials, products or information provided hereunder, including the sale, distribution, reproduction or use of Skyworks products, information or materials, except as may be provided in Skyworks Terms and Conditions of Sale.

THE MATERIALS, PRODUCTS AND INFORMATION ARE PROVIDED "AS IS" WITHOUT WARRANTY OF ANY KIND, WHETHER EXPRESS, IMPLIED, STATUTORY, OR OTHERWISE, INCLUDING FITNESS FOR A PARTICULAR PURPOSE OR USE, MERCHANTABILITY, PERFORMANCE, QUALITY OR NON-INFRINGEMENT OF ANY INTELLECTUAL PROPERTY RIGHT; ALL SUCH WARRANTIES ARE HEREBY EXPRESSLY DISCLAIMED. SKYWORKS DOES NOT WARRANT THE ACCURACY OR COMPLETENESS OF THE INFORMATION, TEXT, GRAPHICS OR OTHER ITEMS CONTAINED WITHIN THESE MATERIALS. SKYWORKS SHALL NOT BE LIABLE FOR ANY DAMAGES, INCLUDING BUT NOT LIMITED TO ANY SPECIAL, INDIRECT, INCIDENTAL, STATUTORY, OR CONSEQUENTIAL DAMAGES, INCLUDING WITHOUT LIMITATION, LOST REVENUES OR LOST PROFITS THAT MAY RESULT FROM THE USE OF THE MATERIALS OR INFORMATION, WHETHER OR NOT THE RECIPIENT OF MATERIALS HAS BEEN ADVISED OF THE POSSIBILITY OF SUCH DAMAGE.

Skyworks products are not intended for use in medical, lifesaving or life-sustaining applications, or other equipment in which the failure of the Skyworks products could lead to personal injury, death, physical or environmental damage. Skyworks customers using or selling Skyworks products for use in such applications do so at their own risk and agree to fully indemnify Skyworks for any damages resulting from such improper use or sale.

Customers are responsible for their products and applications using Skyworks products, which may deviate from published specifications as a result of design defects, errors, or operation of products outside of published parameters or design specifications. Customers should include design and operating safeguards to minimize these and other risks. Skyworks assumes no liability for applications assistance, customer product design, or damage to any equipment resulting from the use of Skyworks products outside of stated published specifications or parameters.

Skyworks, the Skyworks symbol, and "Breakthrough Simplicity" are trademarks or registered trademarks of Skyworks Solutions, Inc., in the United States and other countries. Third-party brands and names are for identification purposes only, and are the property of their respective owners. Additional information, including relevant terms and conditions, posted at www.skyworksinc.com, are incorporated by reference.