

# Type 15H, 9U – 19" Rack Mount, High Availability Chassis



## Features

- 19" Rack mount/ Desktop fully compliant to IEEE 1101.10/.11
- 9U x 84HP x 290mm (H x W x D)
- 4, 6, 8 or 16-slot, PICMG: 2.0, 2.16, 2.17, 2.20 backplanes (H.110 optional)
- Redundant cooling front to rear 3 x 90 CFM below cards, 2 x 40 CFM radial blowers above cards
- Advanced EMC shielding to meet CE, FCC Class A and NEBS
- Wide range of PSU inputs (90 – 264 VAC, 48 VDC)
- Wide range of PSU options: fix mount, plug in, N+1
- Shelf Management: PICMG 2.9, IPMI (optional)
- Ready to run – turnkey solution

## Scope of Supply

High quality 19" rack mount chassis platform consisting of scratch resistant, powder coated alodined aluminum enclosures, high performance PICMG 2.0, 2.16, 2.17 backplane, power supply, cooling system and AC/DC power components. Assembled, wired and tested prior to shipment.

## Order Information

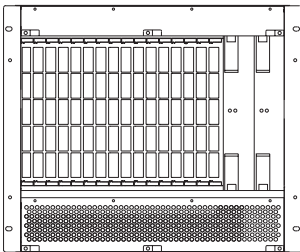

Description	Order Number
<ul style="list-style-type: none"> <li>■ 9U H x 84HP W x 290mm D</li> <li>■ 16 slot, 6U x 160mm, front</li> <li>■ 16 slot, 6U x 80mm, rear I/O</li> <li>■ 16 slot BP, (PICMG 2.0, w/H.110)</li> <li>■ Front to rear, redundant cooling</li> <li>■ 3 x 90 CFM fans, 2 x 50CFM radial blowers</li> <li>■ 2 x 350W PSU – 6U, Plug removable, N+1</li> </ul>	<b>15H16CCX98Y3VP4X</b>

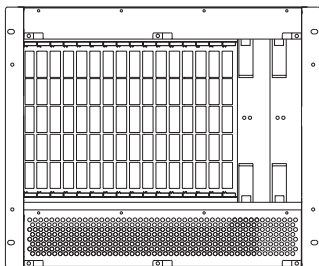

Description	Order Number
<ul style="list-style-type: none"> <li>■ 9U H x 84HP W x 290mm D</li> <li>■ 16 slot, 6U x 160mm, front</li> <li>■ 16 slot, 6U x 80mm, rear I/O</li> <li>■ 16 slot BP, (PICMG 2.16, 2 x FS, wo/H.110)</li> <li>■ Front to rear, redundant cooling</li> <li>■ 3 x 90 CFM fans, 2 x 50CFM radial blowers</li> <li>■ 2 x 350W PSU – 6U, Plug removable, N+1</li> </ul>	<b>15C16HCX98Y3VP4X</b>

## Line Drawings

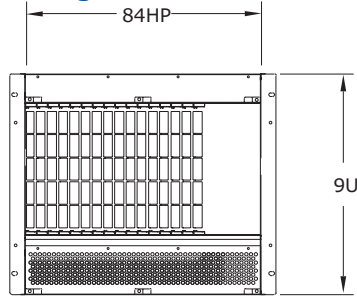

Front View

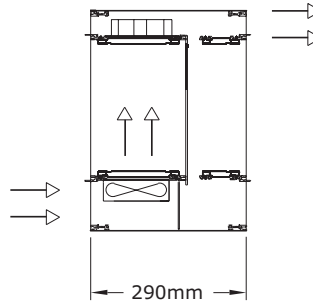

Right Side View

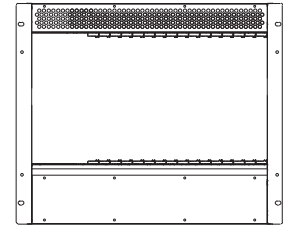

Rear View

## Environmental

	Operating	Storage/Transit
<b>Temperature:</b>	0°C to +50°C	-20°C to +70°C
<b>Altitude:</b>	6000 ft. (1,829m)	50,000 ft. (15,240m)
<b>Humidity:</b>	5% to 95% Non condensing	5% to 95% Non condensing
<b>Shock:</b>	10 G's @ 11ms	15 G's @ 11ms (per ASTM 0775)
<b>Vibration:</b>	1.0 G's @ 10 to 330 Hz	1.2 G's @ 5 to 330 Hz
<b>Agencies:</b>	Designed to meet UL60950, FCC Class A, A, CE	

## Custom Configurations

1 5 H     9 8 Y 3 V

### Backplane Configuration

00-21: Single BP, AA-YY: Split  
 02 = 2 slot  
 04 = 4 slot  
 06 = 6 slot  
 08 = 8 slot  
 16 = 16 slot  
 DD = 4+4  
 FF = 6+6  
 HH = 8+8

### Bare Board

A = 6U Eco, ATX, (RSS)  
 B = 3U Rev. 2.0  
 C = 6U H110  
 D = 6U (LSS)  
 E = 2.16, 1 x FS (no H.110)  
 F = 2.16, 2 x FS (no H.110)  
 H = 2.16, 2 x FS (w/ H.110)  
 I = 2.16, 1 x FS (w/ H.110)  
 X = No BP installed  
 Z = Custom

### BP Connector

A = P1 & P2 S; No P3,P4, P5  
 B = P1 S, P2 L; No P3,P4, P5  
 C = P1, P2 & P4 S; P3 & P5 L  
 D = P1 & P2 S; P3, P4, P5 L  
 E = P1 S; P2, P3, P4, P5 L  
 F = P1 & P4 S; P2, P3, P5 L  
 G = P1 & P2 S; P3 L, no P4, P5  
 H = 2 x PC: P1, P2 & P4 S; P3 & P5 L  
 I = 2 x 47 PIN Power  
 X = No connectors  
 Z = Custom

### Drives

1 = 1 X 3.5"  
 2 = 2 X 3.5"  
 3 = 1 X 5.25" H  
 4 = 2 X 5.25"HH  
 5 = 4 X 5.25" HH  
 6 = 2 X 3.5", 1 X 5.25"HH  
 7 = 1 X 3.5", 2 X 5.25"HH  
 8 = 2 X 3.5", 2 X 5.25"HH  
 9 = 1 X 3.5", 1 X 5.25"HH  
 A = 1 x 2.5", 1 X CDROM (SL)  
 B = 2 x 2.5"  
 X = Not installed

### Height

9 = 9U

### Width

8 = 84T

### Rear IO

Y = Yes

### Depth

3 = 290mm/305mm/340mm

### Card Orientation

V = Vertical

### PSU Input

C = 90-230VAC (Fixed)  
 E = 110/220VAC (2 x HS, N+1)  
 G = 90-230VAC (Plug In)  
 H = 48VDC (Plug In)  
 K = 48VDC (Fixed)  
 L = 48VDC (2 x QC, N+1)  
 M = 48VDC (2 x HS, N+1)  
 P = 90-230VAC (2 x HS, N+1)  
 Q = 90-230VAC (3 x HS, N+1)  
 R = 28VDC (Fixed)  
 S = 48VDC (3 x HS, N+1)  
 X = No PSU

### PSU Output

(Note: Not all PSU combinations available)

1 = 150 W  
 2 = 200/250 W (4U, 6U or fixed)  
 3 = 300 W (4U/6U, ATX)  
 4 = 350 W (6U plug in only)  
 5 = 350 W (Brick)  
 6 = 500 W (Brick)  
 7 = 300 W (4U or 6U, PS2 Hot Swap)  
 8 = 200 W (6U x 4T)  
 9 = 750 W (Brick)  
 A = 1000 W (Brick)  
 B = 1200 W (Brick)  
 C = 1500 W (Brick)  
 X = Not installed

### Voltage IO

3 = 3.3V  
 5 = 5V  
 X = Not installed