

Ventilation

Fan modules for vertical ventilation

19" fan module

for vertical ventilation

220V/50Hz (115V on request)



Assembled ready for connection

Card depth	1U	2U
160 mm 6.29"	27-100-02	27-200-02
220 mm 8.66"	27-101-02	27-201-02

1U version with fan type 69-430-20

2U version with fan type 1925-79

In kit form, without fan and wiring

Card depth	1U	2U
160 mm 6.29"	27-100-85	27-200-85
220 mm 8.66"	27-101-85	27-201-85

19" fan module

for horizontal ventilation

220V/50Hz (115V on request)



Assembled ready for connection

Card depth	1U	2U
160 mm 6.29"	–	27-250-02
220 mm 8.66"	–	27-251-02

with fans type 1925-79

In kit form, without fan and wiring

Card depth	1U	2U
160 mm 6.29"	–	27-250-85
220 mm 8.66"	–	27-251-85

Line drawing

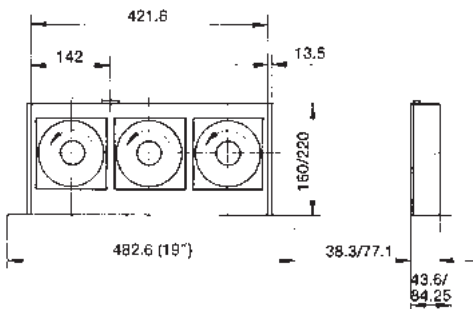

Power supply

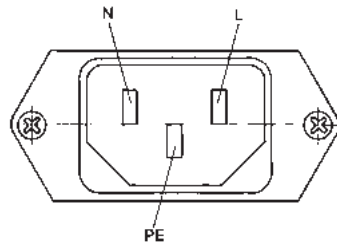

N – blue
L – brown
PE – green/yellow

1 AMP connector series M can be assembled additionally

84HP fan module vertical

220V/50Hz (115V on request)



Assembled ready for connection

Card depth	1U	2U
160 mm 6.29"	27-110-02	27-210-02
220 mm 8.66"	27-111-02	27-211-02

1U version with fans type 69-430-20

2U version with fans type 1925-79

In kit form, without fan and wiring

Card depth	1U	2U
160 mm 6.29"	27-110-85	27-210-85
220 mm 8.66"	27-111-85	27-211-85

84HP fan module horizontal

220V/50Hz (115V on request)



Assembled ready for connection

Card depth	1U	2U
160 mm 6.29"	-	27-260-02
220 mm 8.66"	-	27-261-02
160 mm 8.66" recessed	-	27-265-02

with fans type 1925-79

In kit form, without fan and wiring

Card depth	1U	2U
160 mm 6.29"	-	27-260-85
220 mm 8.66"	-	27-261-85

Line drawings

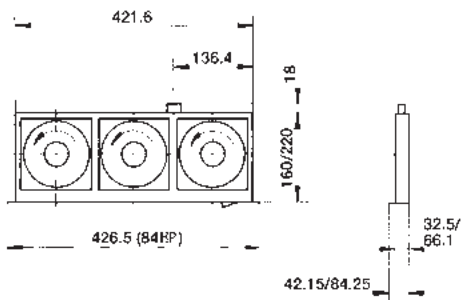

Power supply

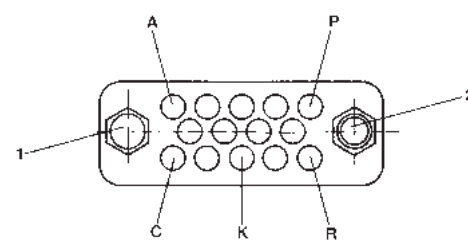

- 1 coding socket
- 2 coding pin
- A-N – blue
- C-Na – blue
- K-PE – green/yellow
- P-L – brown
- R-La – brown

The fan module is inserted in the case or rack on card guides.

The AMP connector on the inserted fan module makes contact with the socket mounted on the rear extrusion.

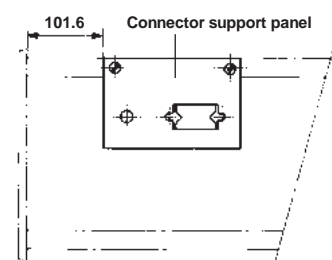
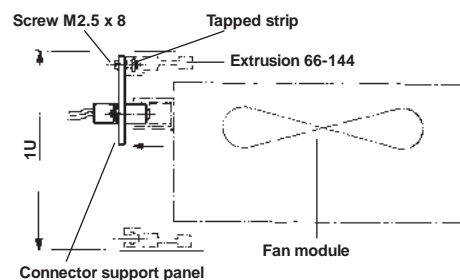
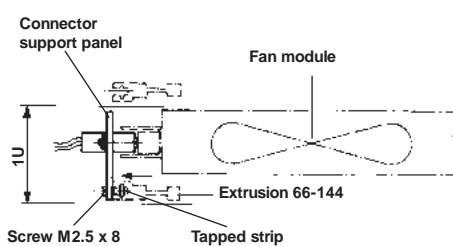

Ventilation

Fan

12V DC fan

- Brushless
- Sealed ball bearings
- Polarity and electronic locked rotor protection (autorestart)
- Air exhaust in over struts (can be mounted directly on a perforated front panel)
- Connector 2.8 x 0.5 (except fan with speed sensor)
- Fan case and wheel plastic UL94V-0
- Operating temperature -20 °C to +70 °C
- CE, UL, CSA, VDE standard
- Life expectancy $L_{10} = 70\,000$ hours at 40 °C
- Special configuration with speed sensor

Part No.	VDC	Voltage range VDC	Power consumption W**	Current consumption mA**	Rotational speed min ⁻¹	Noise dB (A)**	max. stat. pressure mm H ₂ O	Flow rate m ³ /h	Dimensions					
									A mm	inch	B mm	inch	C mm	inch
69-430-23	12	6.0-13.8	3.80	315	3200	41	4.8	93	92.0	3.62	82.5	3.24	25.0	0.98
69-430-25	12	6.0-13.8	1.80	150	1600	29	2.4	102	119.0	4.68	105.0	4.13	25.0	0.98
69-430-26	12	6.0-13.8	6.80	570	2400	39	5.0	153	119.0	4.68	105.0	4.13	25.0	0.98
69-430-27	12	6.0-13.8	8.40	700	3200	46	8.3	200	119.0	4.68	105.0	4.13	38.4	1.51
69-430-28*	12	6.0-13.8	8.40	700	3200	46	8.3	200	119.0	4.68	105.0	4.13	38.4	1.51
69-430-32*	12	6.0-13.8	3.80	315	3200	41	4.8	93	92.0	3.62	82.5	3.24	25.0	0.98

* with speed sensor ** with free exhaust

230V/115V AC fan

- Split-pole motor
- Sealed ball bearings
- Impedance protection resp. integrated thermal switch
- Connector 2.8 x 0.5
- Air exhaust in over struts (can be mounted directly on a perforated front panel)
- Fan case: aluminum
- Fan wheel: plastic UL94V-0
- Operating temperature -40 °C to +70 °C
- CE, UL, CSA, VDE standard
- Life expectancy $L_{10} = 50\,000$ hours at 40 °C

Part No.	VAC	Freq. Hz	Power consumption W**	Current consumption mA**	Rotational speed min ⁻¹	Noise dB (A)**	max. stat. pressure mm H ₂ O	Flow rate m ³ /h	Dimensions					
									A mm	inch	B mm	inch	C mm	inch
69-430-20	230	50/60	14.0/11.0	100/ 90	2300/2700	34/38	4.25/4.25	108/120	119.0	4.68	105.0	4.13	25.0	0.98
69-430-30	230	50/60	13.0/10.0	90/ 70	2600/3100	34/38	6.0 /4.25	48/ 59	92.0	3.62	82.5	3.24	25.0	0.98
69-430-31	115	50/60	12.0/ 9.0	170/130	2600/3100	34/38	6.0 /4.25	48/ 59	92.0	3.62	82.5	3.24	25.0	0.98
69-430-41	115	50/60	15.0/13.0	250/210	2600/2900	37/41	9.0 /7.3	162/192	119.0	4.68	105.0	4.13	38.0	1.51
69-430-43	115	50/60	14.0/11.0	190/160	2300/2700	34/38	4.25/4.25	108/120	119.0	4.68	105.0	4.13	25.0	0.98
1925-79	230	50/60	15.0/14.0	120/100	2600/2900	37/41	9.0 /7.3	162/192	119.0	4.68	105.0	4.13	38.0	1.51

** with free exhaust

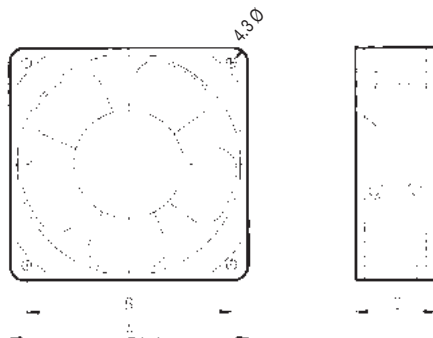

Ventilation accessories

Temperature regulator

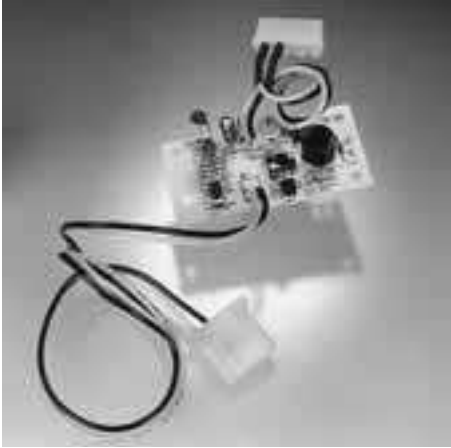

Part	Part No.
Temperature regulator (incl. wiring)	7731-02

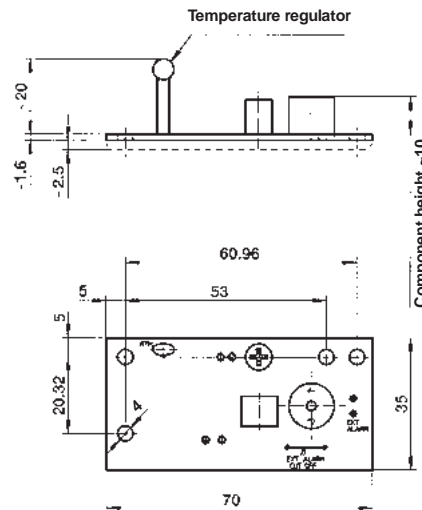

- Temperature regulator with acoustic alarm signal
- Simple conversion to external optical signal
- Range of regulation – fan regulating range:
 - min. speed up to 34 °C,
 - max. speed at 48 °C
- alarm regulating range: adjustable between 45 °C and 54 °C
- Voltage 12 V/DC
- voltage range 10÷14 V/DC
- Temperature regulator current consumption 50 mA
- Max. current consumption 0,6 A
- Operating temperature 0÷65 °C
- Storage temperature -20 °C ÷ +80 °C

Cover panel

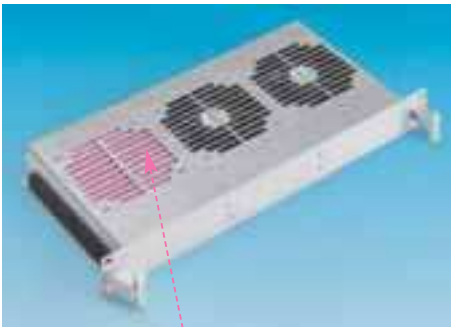

Part	Part No.
Cover panel	27-041

Fixing material

Part	Part No.
Set for 1 cover panel	63-823

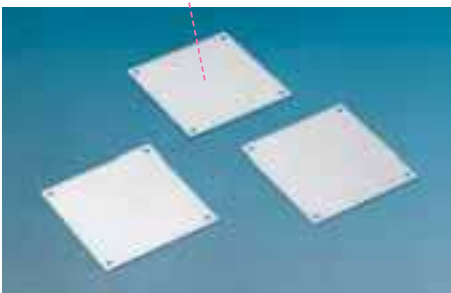

Handles for 19" fan module



Height	Packing unit	Part No.
1U	1 piece	60-541
2U	1 piece	60-522

Fixing material has to be ordered separately (page 136)

Ventilation

Filter set on pressure side for 2U module



The filter mat can be regenerated (by washing in water at approx. 40 °C).

Part	Part No.
Filter set 19"/2U	27-280

Replacement filter

Part	Part No.
Packing unit 10 pieces	63-822-03

Front filter set for 2U module



The filter mat can be regenerated (by washing in water at approx. 40 °C).

Part	Part No.
Front filter set for 19" fan module and 19" front panel 20-102-01 and 84HP front panel 21N284-01/02	27-281
Front filter set for 84HP fan module and 84HP EMC front panel 21E284-01	27-282

Replacement filter

Part	Packing unit	Part No.
Replacement filter for front filter 19"	packet with 3	63-822-04
Replacement filter for front filter 84HP	packet with 3	63-822-05

Fan-mounting panels

Aluminum 1.5 mm

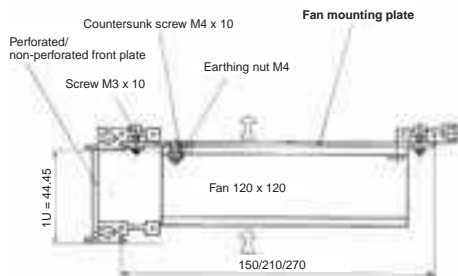

Fan-mounting panels for vertical ventilation

Case width	No. of fans	Fan size		Part No.
		mm x mm	inch x inch	
42÷84HP	1	120 x 120	4.8 x 4.8	27-048
84HP (card depth 160 mm)	3	120 x 120	4.8 x 4.8	27-043
84HP (card depth 220 mm)	3	120 x 120	4.8 x 4.8	27-057
84HP (card depth 280 mm)	6	120 x 120	4.8 x 4.8	27-029

Fixing material has to be ordered separately (page 136/137)

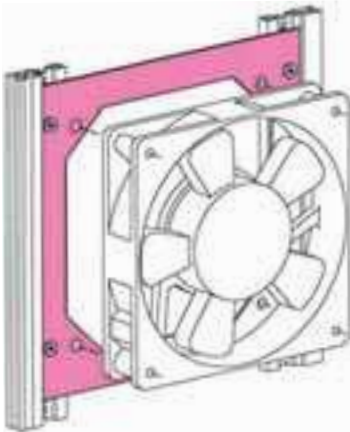

Fan-mounting panels for cross-flow ventilation (horizontal mounting kits)

Mounting height	No. of fans	Fan size		Part No.
		mm x mm	inch x inch	
3U	1	90 x 90	3.6 x 3.6	27-049
4U	1	120 x 120	4.8 x 4.8	27-048
6U	2	120 x 120	4.8 x 4.8	27-047

Fixing material

Part	Part No.
Round head screw M3 x 10, 100 pieces	1910-14
Countersunk screw M4 x 10, 100 pieces	1906-24
Earthing nut M4, 100 pieces	63-197
Fixing material for 1 fan M4	63-823

Air baffle cover



Part	Part No.
Air baffle cover = 160 mm 6.29"	27-290
Air baffle cover = 220 mm 8.66"	27-291

By using the air baffle cover the cooling air flow can be regulated.

Back cover panel



Back cover panels for front flush-mounted cards

Part	Part No.
Back cover panel 1U/84HP	61-630
Back cover panel 2U/84HP	61-631

Back cover panels for recess-mounted cards

Part	Part No.
Back cover panel 1U/84HP	61-634
Back cover panel 2U/84HP	61-635

When components are cooled by fan ventilation (fan modules, fixed fans, etc.), the back cover panel prevents exhaust air from being drawn in and recirculated.