

TestStation™ Debug Pro

Simple and Powerful Debug Environment for TestStation In-Circuit Testers

Key Features:

- Navigate through tests using only a mouse
- Visual icons conveniently display test status
- Views can be customized to display only test parameters of interest
- No need for Operator to learn a test language or debug commands
- Circuit, component, and property information available at operator's fingertips
- Charting tools report test reliability and show test statistics

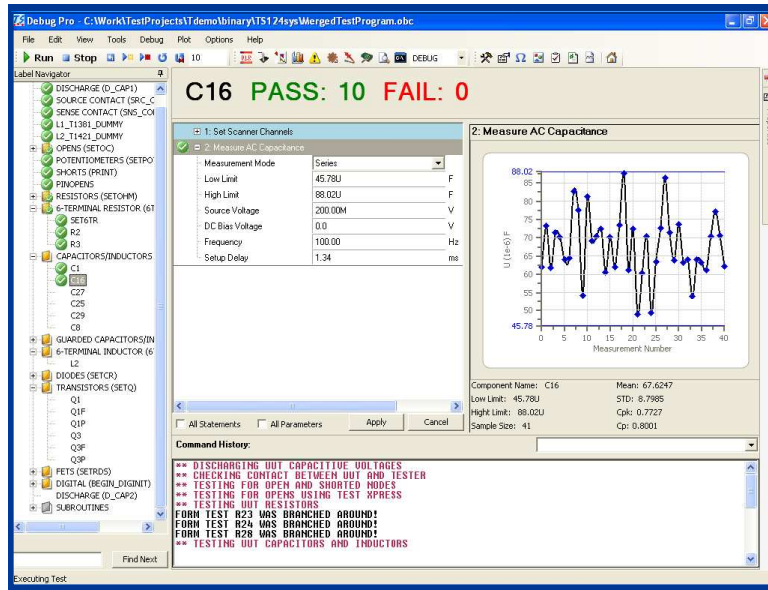

TestStation Debug Pro helps simplify ICT debug and improve program quality.

TestStation Debug Pro is Teradyne's new user-friendly interface for debugging, developing and qualifying in-circuit test programs. Its graphical interface incorporates the latest software technologies to provide simple and intuitive access to TestStation's powerful features and debug environment. Key elements of *TestStation Debug Pro* include:

- A **Label Navigator** that graphically displays all the tests in the program. Common component tests for resistors, capacitors, inductors, and others are conveniently grouped in folders. Status icons are used to clearly indicate the Pass/Fail status of each test. Operators can select individual tests to debug by clicking on them or by using built-in search capability.
- A **Statement Editor** displays all of the parameters available for selected tests and allows operators to easily select and modify those parameters using a mouse or simple keystrokes. The display can be further simplified to display only test parameters that the operator typically changes during debug activities.
- A **Guard Editor** window shows test instrument connections and circuit inter-

connections associated with the device under test. Operators can easily add and remove test guard points using the mouse.

- A **Charting Tool** displays measurement results using run or histogram charts and reports test statistics like Mean, Std Deviation, Cp, and Cpk. Operators can view the charts to quickly determine the reliability of the test measurements.
- **Component and Property Information** windows display helpful information about board components, values, tolerances, pins, nets, and nails.
- **Customizable Tool Bar** that provides access to powerful debug tools like board and schematic viewers, data collection charts, vectorless test programming, and test quality tools.
- An optional **Untranslator Window** allows long-time experienced users to continue performing debug activities using the familiar commands and keystrokes of the traditional Runtime debug environment.

User benchmarks show that the intuitive operation and advanced capabilities of *TestStation Debug Pro's* user interface help operators complete their debug activities faster with higher quality results.

Benefits of TestStation Debug Pro:

- Faster learning curve for new users
- Faster access to advanced debug features
- Faster analysis of test measurement results
- Finger tip access to component, property, and connection information
- Automatic circuit analysis and suggested guard points
- Accommodates both experienced and inexperienced test developers

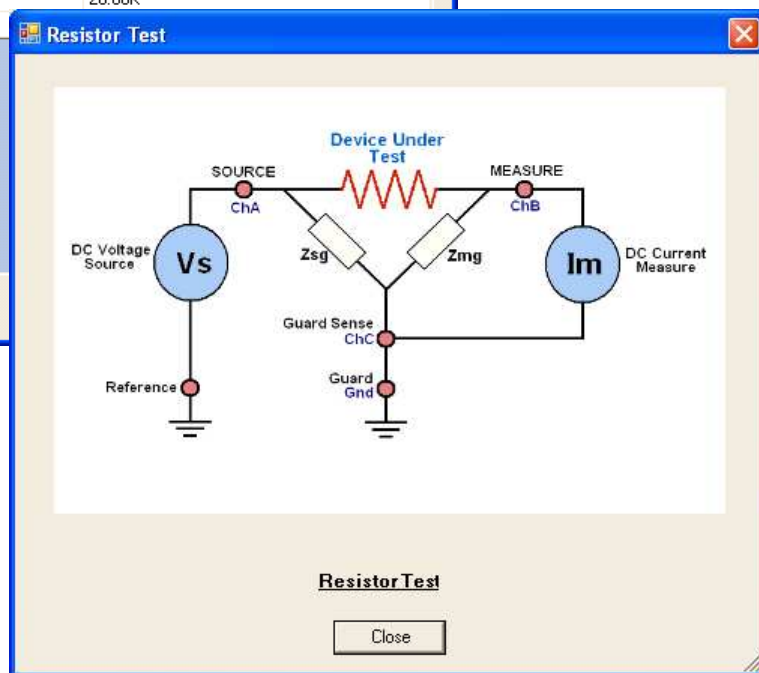
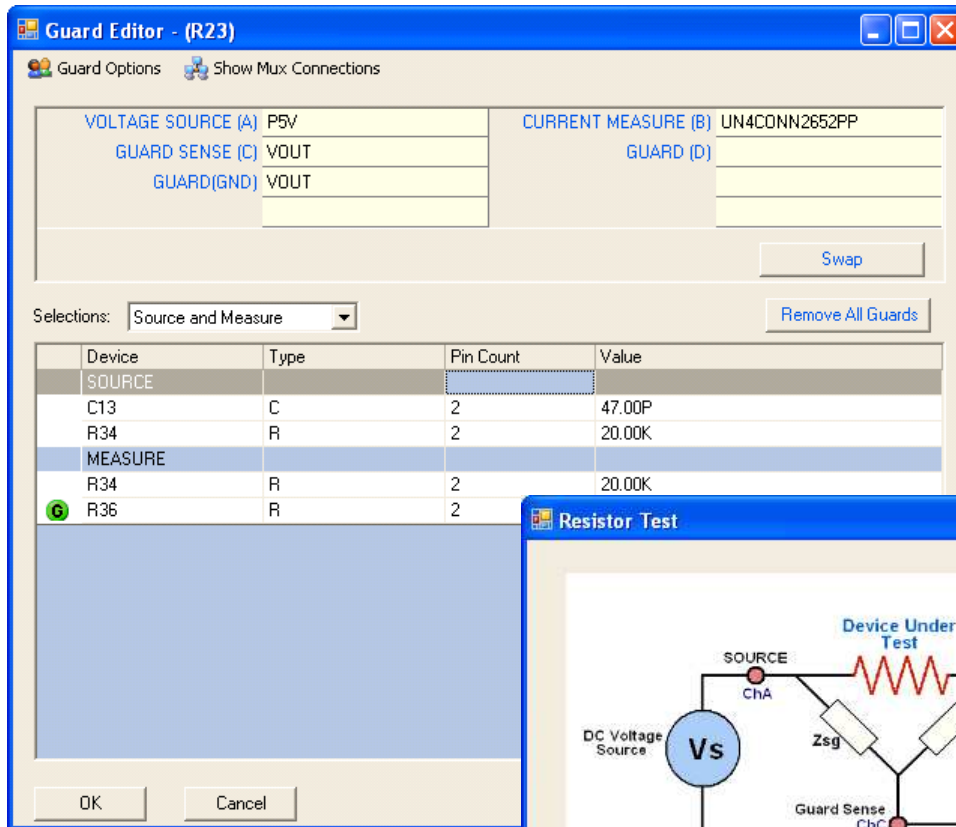

Contact your Teradyne sales representative for more information or visit www.teradyne.com/atd.

Teradyne, Inc.
Systems Test Group
700 Riverpark Drive
North Reading, MA 01864
U.S.A.
+1.978.370.2700
www.teradyne.com/atd

TestStation and Framescan are trademarks of Teradyne, Inc. All other brand and product names are trademarks or registered trademarks of their respective owners. Information contained in this document is summary in nature and subject to change without notice. Appearance of the final, delivered product may vary from the photographs shown herein.

© Teradyne 2011–All rights reserved,

STG-TSP-2011-01