

# Proposal



- RF Filter Designed for Front End GPS Applications
- Excellent Rejection
- 1.45 x 1.15 mm Surface-Mount Case
- Complies with Directive 2002/95/EC (RoHS)



**SF1186K-5**

**1575.42 MHz  
SAW Filter**

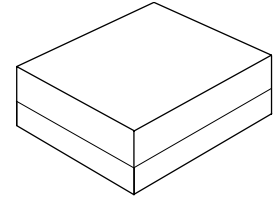

**SM1411-5**

## Absolute Maximum Ratings

Rating	Value	Units
Maximum Incident Power in Passband	+10	dBm
Maximum DC Voltage On any Non-ground Terminal	3	VDC
Operating Temperature Range	-40 to +85	°C
Component Storage Temperature Range	-55 to +95	°C
Storage Temperature Range in Tape and Reel	-40 to +85	°C
Maximum Soldering Temperature Profile (5 cycles maximum)	265 °C for 10 s	

## Electrical Characteristics

Characteristic	Sym	Notes	Min	Typ	Max	Units
Center Frequency	$f_C$		1575.42			MHz
Insertion Loss, 1574.42 to 1576.42 MHz	$IL_{MAX}$			1.1	1.6	dB
Amplitude Ripple, 1574.42 to 1576.42 MHz				0.1	0.5	dB <sub>P-P</sub>
Rejection Referenced to 0 dB						dB
100 to 960 MHz			25	27.5		
960 to 1460 MHz			25	28		
1460 to 1513 MHz			25	28		
1648 to 1710 MHz			15	19		
1710 to 1990 MHz			20	24		
1990 to 2300 MHz			25	31		
2300 to 4000 MHz			25	30		
4000 to 6000 MHz			20	24		
VSWR, 1574.42 to 1576.42 MHz				1.3:1	1.9:1	
Terminating Source impedance	$Z_S$			50		$\Omega$
Terminating Load impedance	$Z_L$			50		$\Omega$
Case Style			SM1411-5			
Lid Symbolization $\square$ = year/month manufacturing code			C□			



**CAUTION: Electrostatic Sensitive Device. Observe precautions for handling.**

**Notes:**

1. US and international patents may apply.
2. RFM, stylized RFM logo, and RF Monolithics, Inc. are registered trademarks of RF Monolithics, Inc.

# Frequency Response Plots

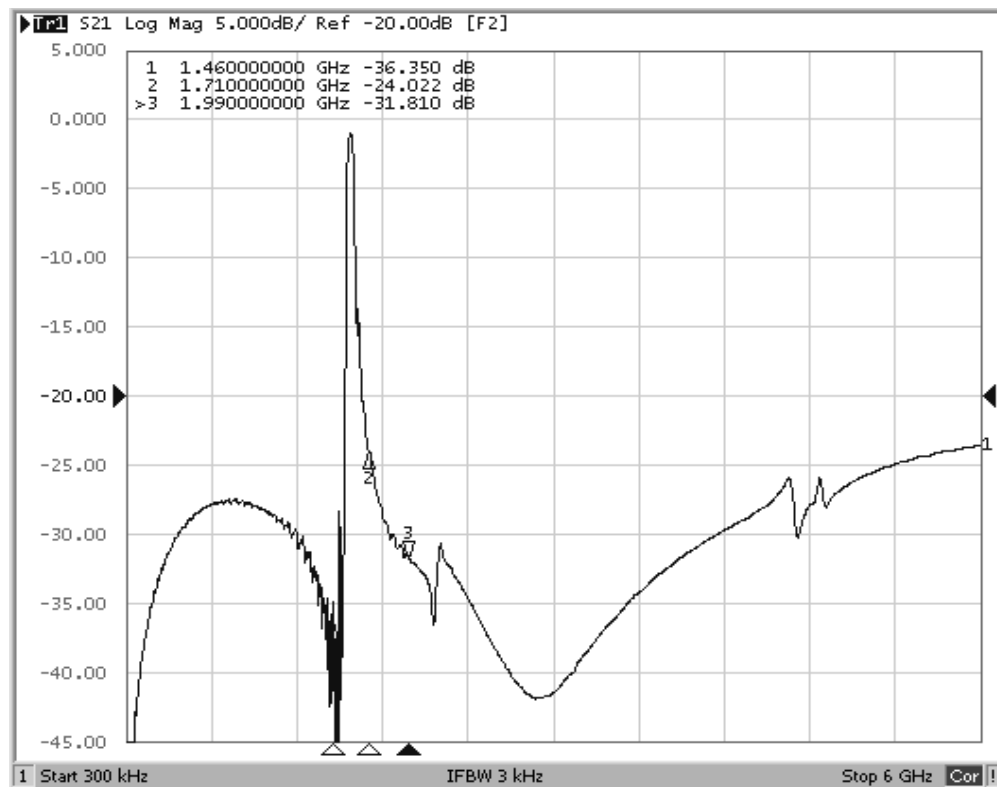
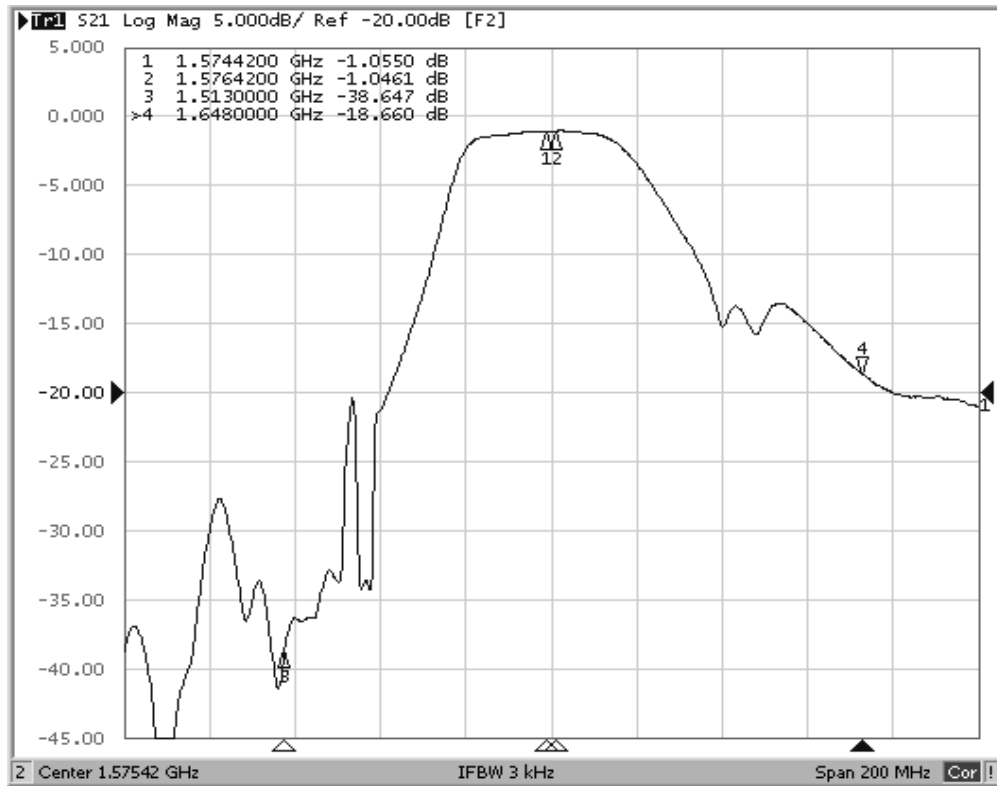

## Input VSWR Plot

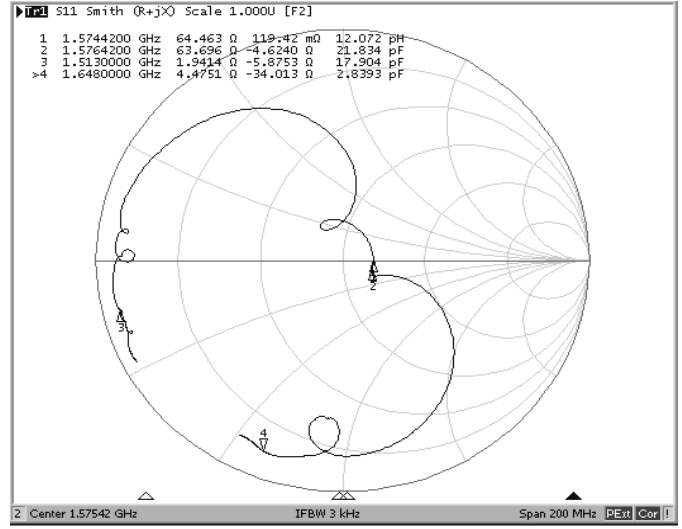
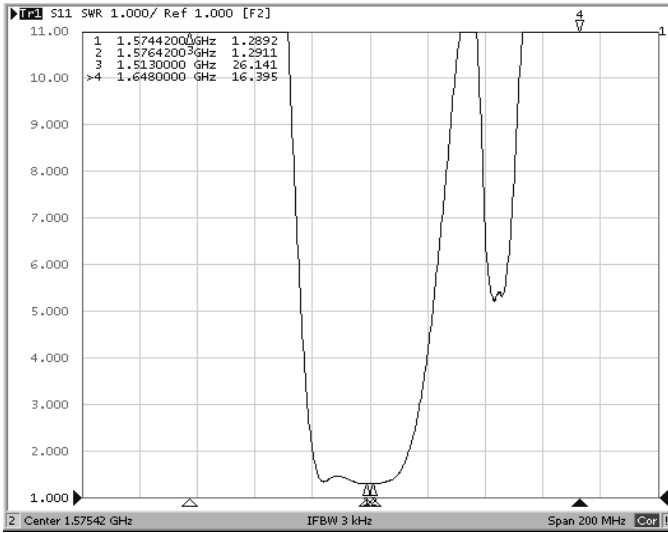

## Output VSWR Plot

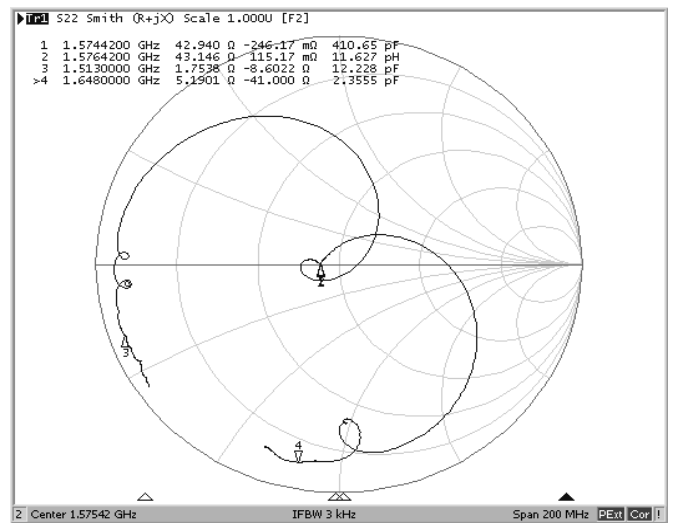
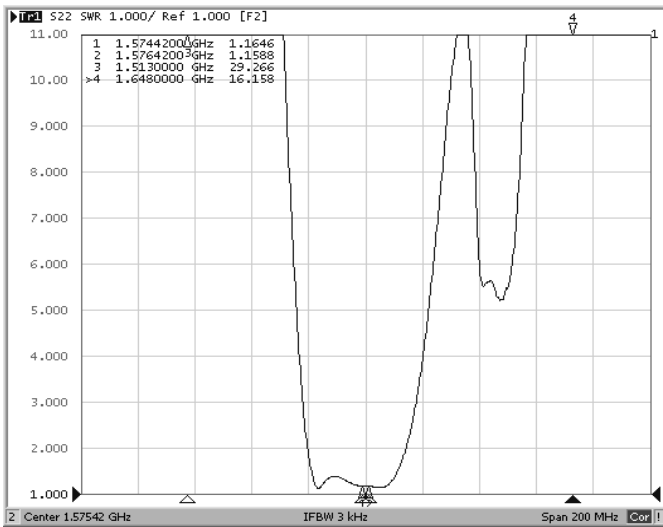

# SM1411-5 1.4 X 1.1 mm 5-Terminal Surface-mount Case Drawing

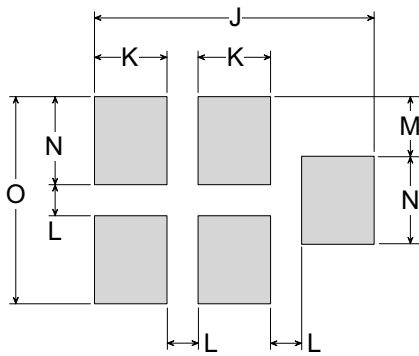
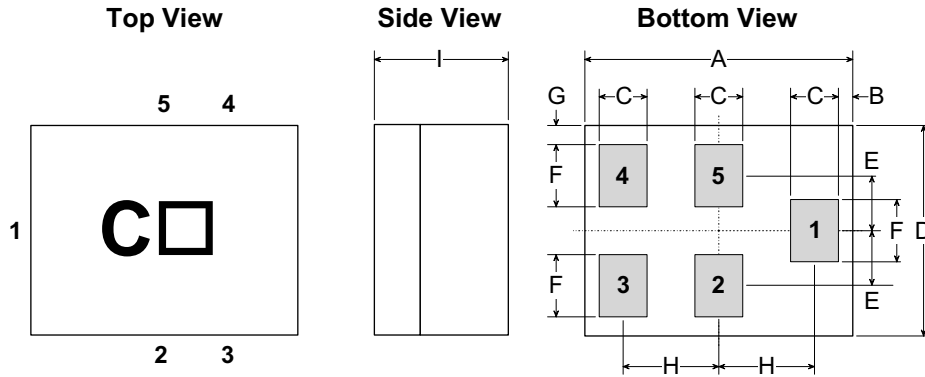

**PCB Footprint**

## Case and PCB Footprint Dimensions

Dimension	mm			Inches		
	Min	Nom	Max	Min	Nom	Max
A	1.3500	1.4000	1.4500	0.0531	0.0551	0.0571
B	-	0.0750	-	-	0.0030	-
C	0.1700	0.250	0.3300	0.0067	0.0098	0.0130
D	1.0500	1.1000	1.1500	0.0413	0.0433	0.0453
E	-	0.2875	-	-	0.0113	-
F	0.2450	0.3250	0.4050	0.0096	0.0128	0.0159
G	-	0.100	-	-	0.0039	-
H	-	0.5000	-	-	0.0197	-
I	0.6000	0.6500	0.700	0.0236	0.0256	0.0276
J	-	1.3500	-	-	0.0531	-
K	-	0.3500	-	-	0.0138	-
L	-	0.1500	-	-	0.0059	-
M	-	0.2875	-	-	0.0113	-
N	-	0.4250	-	-	0.0167	-
O	-	1.0000	-	-	0.0394	-

Materials	
Solder Pad Plating	0.3 to 1.0 $\mu\text{m}$ Gold over 1.27 to 8.89 $\mu\text{m}$ Nickel
Lid Plating	2.0 to 3.0 $\mu\text{m}$ Nickel
Body	$\text{Al}_2\text{O}_3$ Ceramic
Pb Free	

## Test Circuit

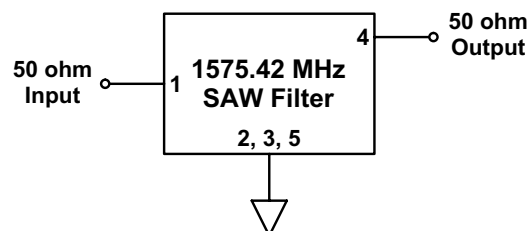

# Reel Dimensions - 7 inch Reel, 3000 Filters

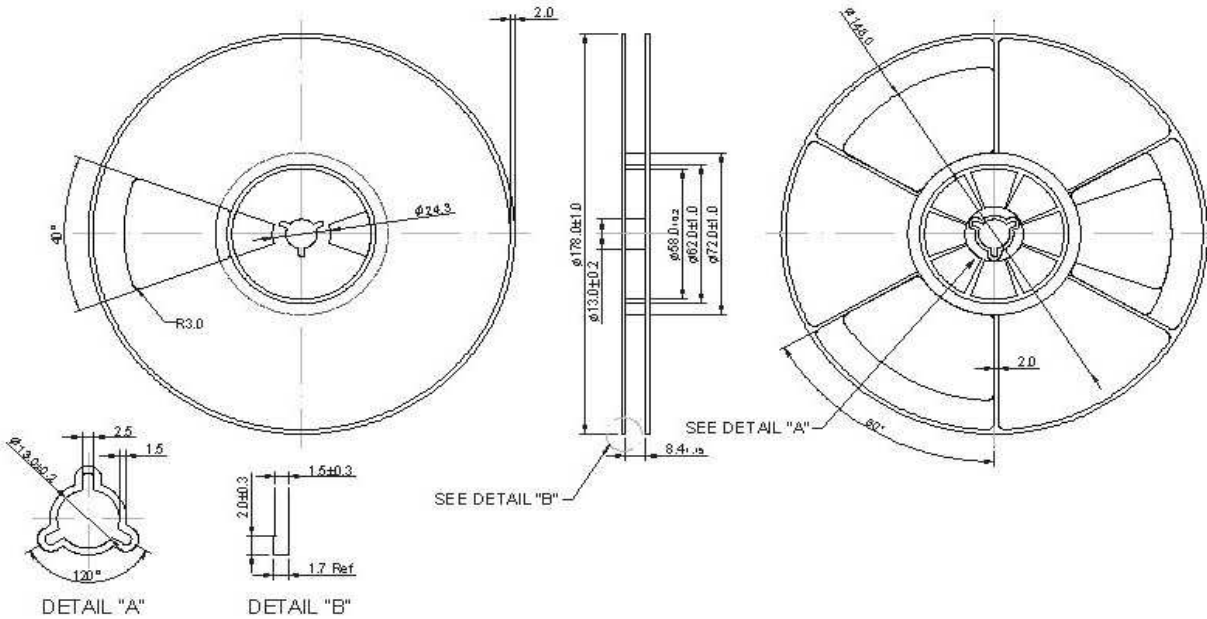

# Tape Dimensions

