



- 925 MHz Low-loss SAW Filter
- Optimized for use with the TRC103 Transceiver
- Balanced 150 ohm IC Interface
- Complies with Directive 2002/95/EC (RoHS) 

**RF3620E**

**925.0 MHz  
SAW Filter**

**Absolute Maximum Ratings**

| Rating                                     | Value      | Units |
|--|------------|-------|
| Input Power Level                          | +15        | dBm   |
| DC Voltage                                 | ±5         | V     |
| Operating Temperature Range                | -40 to +85 | °C    |
| Storage Temperature Range in Tape and Reel | -40 to +85 | °C    |

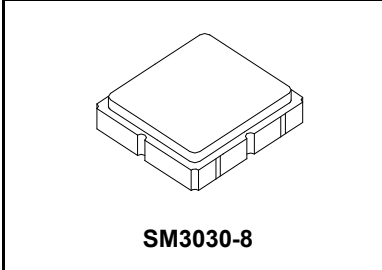

**Electrical Characteristics**

| Characteristic                                       | Sym               | Notes | Min | Typ   | Max | Units |
|--|-------------------|-------|-----|-------|-----|-------|
| Center Frequency                                     | $f_c$             |       |     | 925.0 |     | MHz   |
| 1 dB Bandwidth                                       | BW <sub>1</sub>   | 1     |     | 12    | 16  | MHz   |
| Maximum Insertion Loss, 920.0 to 930.0 MHz           | IL <sub>MAX</sub> |       |     | 2.3   | 3.0 | dB    |
| Amplitude Ripple, p-p, 922.0 to 928.0 MHz            |                   |       |     | 0.5   | 1.0 |       |
| Rejection Referenced to Insertion Loss at 925.0 MHz: |                   |       |     |       |     |       |
| 300 to 810 MHz                                       |                   |       | 36  | 41    |     |       |
| 810 to 895 MHz                                       |                   |       | 46  | 51    |     |       |
| 1000 to 1265 MHz                                     |                   |       | 47  | 52    |     |       |
| 1265 to 2000 MHz                                     |                   |       | 38  | 43    |     |       |
| 2000 to 2500 MHz                                     |                   |       | 30  | 35    |     |       |
| 2500 to 3000 MHz                                     |                   |       | 30  | 35    |     |       |
| Source Impedance                                     | Z <sub>S</sub>    |       |     | 50    |     | Ω     |
| Load Impedance                                       | Z <sub>L</sub>    |       |     | 150   |     | Ω     |

|  |   |                  |  |
|--|---|------------------|--|
| Case Style   | SM3030-8 3.0 x 3.0 mm Nominal Footprint |                  |  |
| Lid Symbolization (Y=year, WW=week, S=shift) dot=pin 1 indicator | A31, YWWS                               |                  |  |
| Standard Reel Quantity   | Reel Size 7 Inch                        | 500 Pieces/Reel  |  |
|  | Reel Size 13 Inch                       | 3000 Pieces/Reel |  |

**Electrical Connections**

| Connection        | Terminals  |
|-------------------|------------|
| Single-ended Port | 6          |
| Balanced Port     | 1, 3       |
| Case Ground       | 4, 5, 7, 8 |
| No Connection     | 2          |



**CAUTION: Electrostatic Sensitive Device. Observe precautions for handling.**

**Notes:**

1. Unless noted otherwise, all specifications apply over the operating temperature range with filter soldered to the specified demonstration board with impedance matching to 50 Ω and measured with 50 Ω network analyzer.
2. Unless noted otherwise, all frequency specifications are referenced to the nominal center frequency,  $f_c$ .
3. Rejection is measured as attenuation below the minimum IL point in the passband. Rejection in final user application is dependent on PCB layout and external impedance matching design. See Application Note No. 42 for details.
4. The design, manufacturing process, and specifications of this filter are subject to change.
5. US and international patents may apply.
6. RFM, stylized RFM logo, and RF Monolithics, Inc. are registered trademarks of RF Monolithics, Inc.

## RF3620E-TRC103 Application Circuit

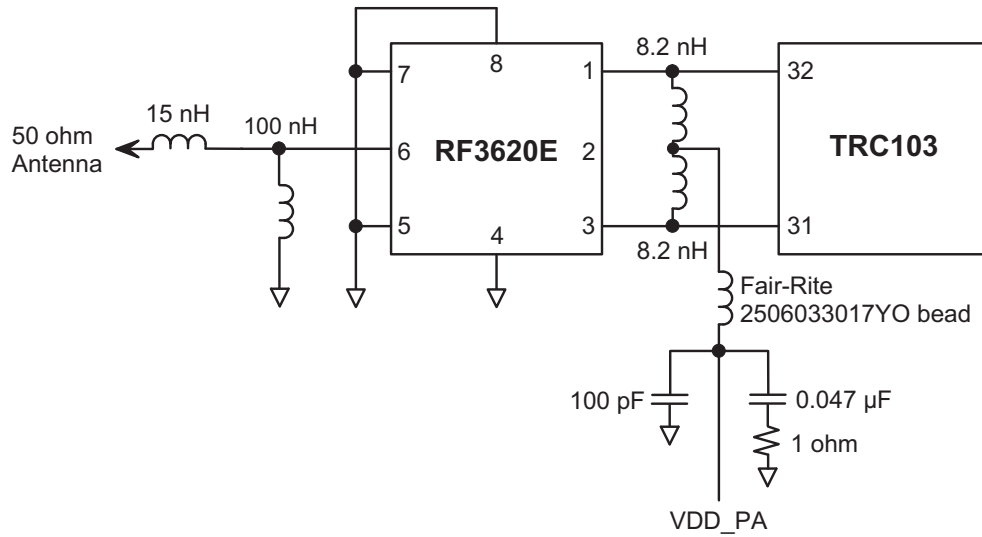

# RF3620E Passband Response

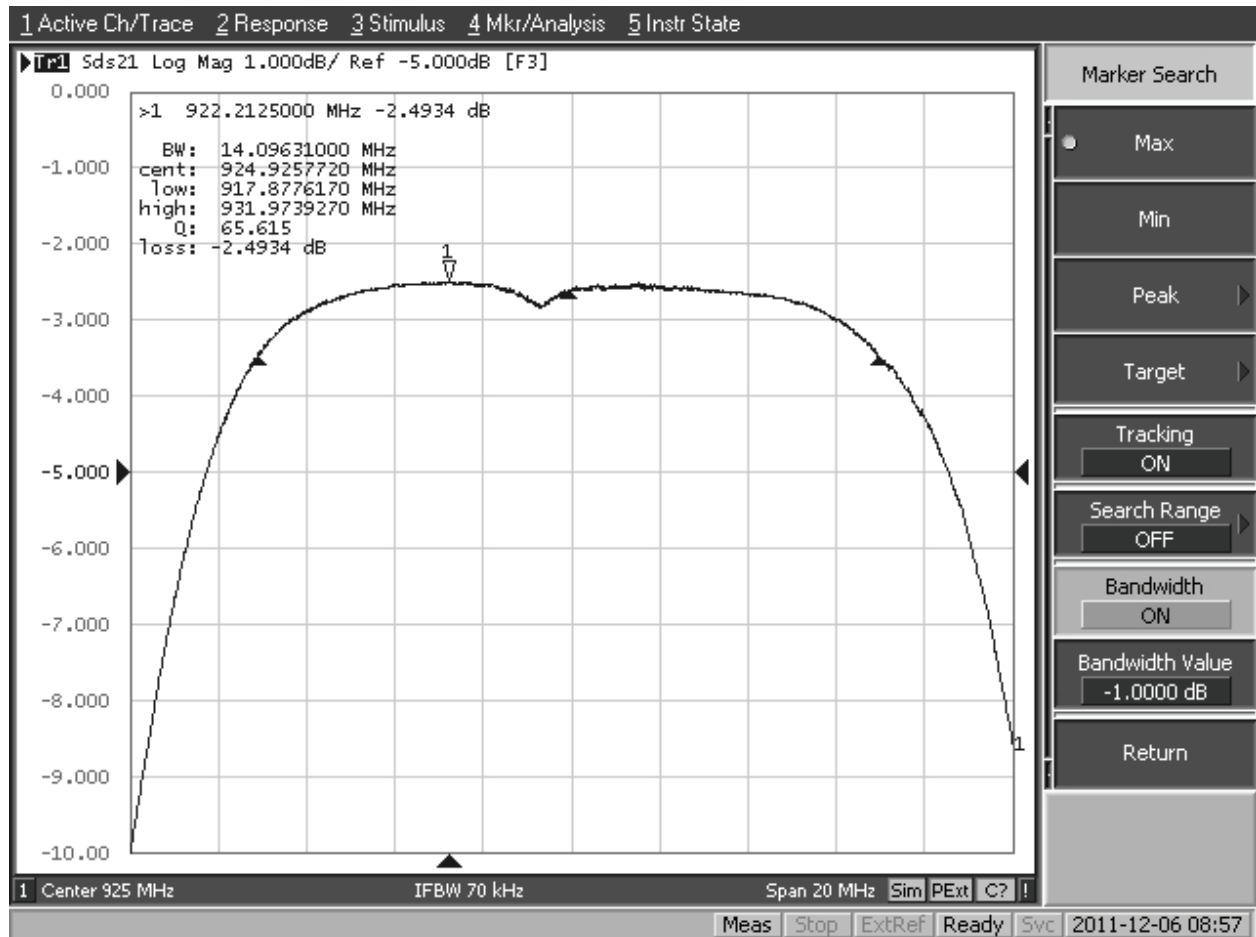

# RF3620E Response, 875 to 975 MHz

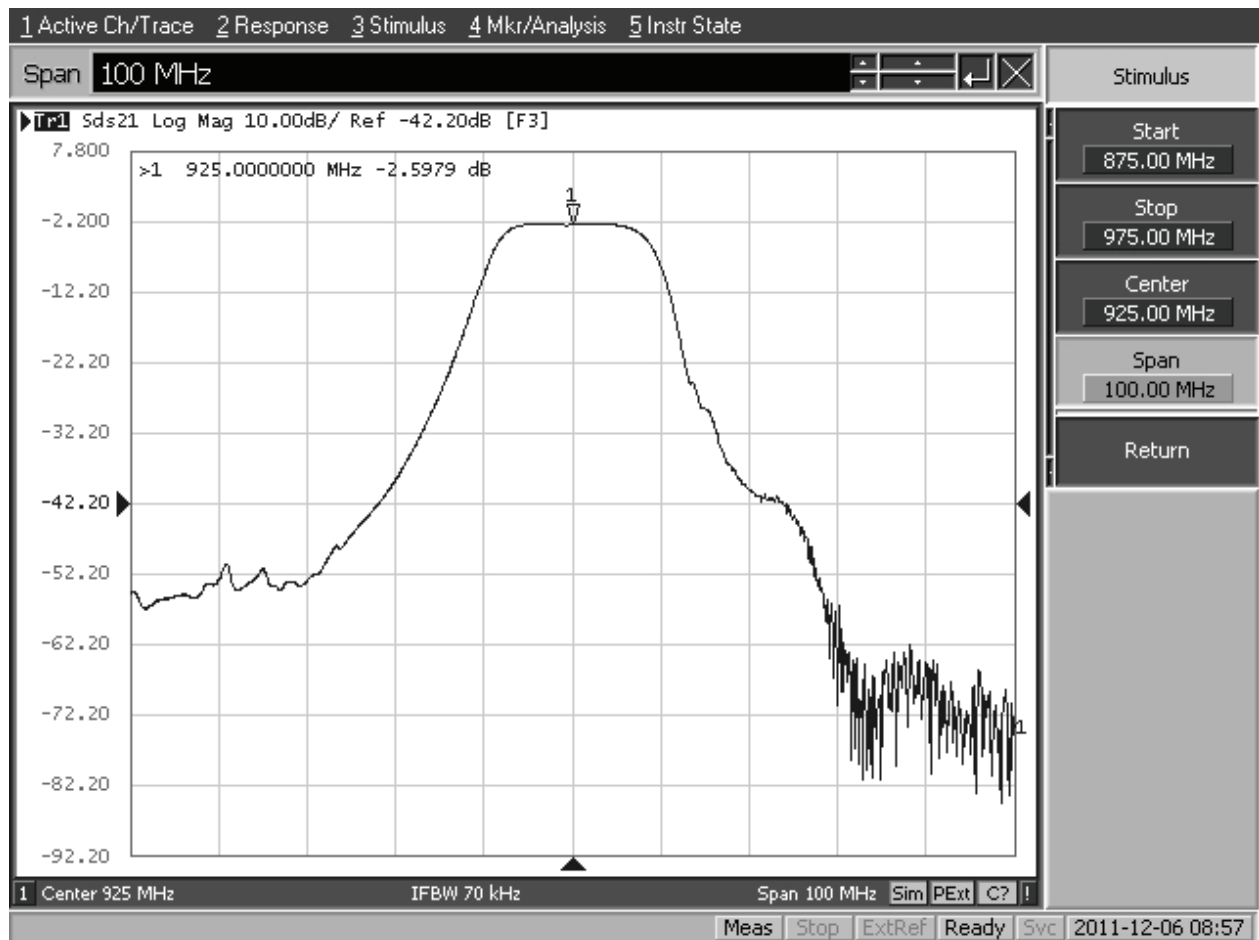

## RF3620E Response, 675 to 1175 MHz

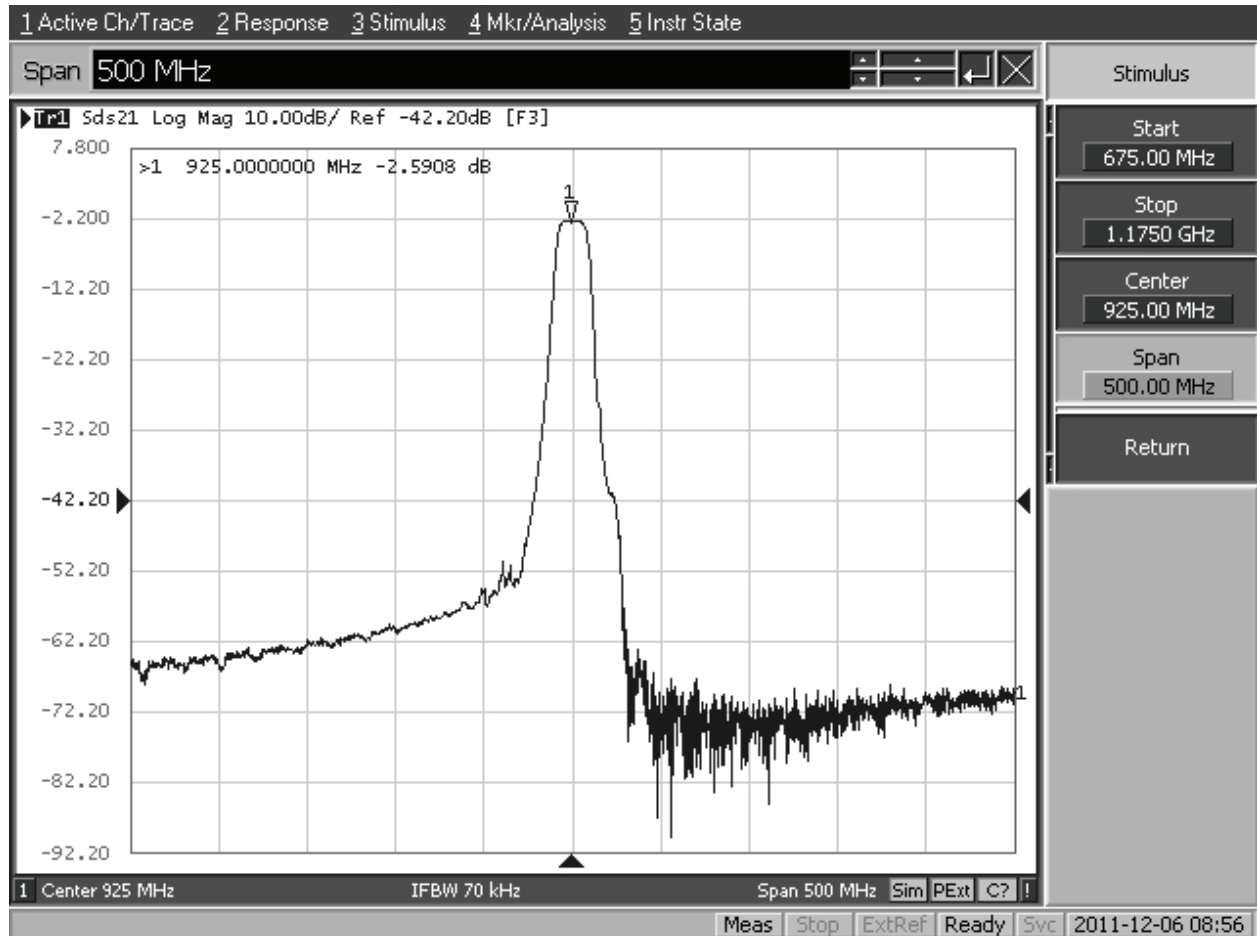

# RF3620E Broadband Response

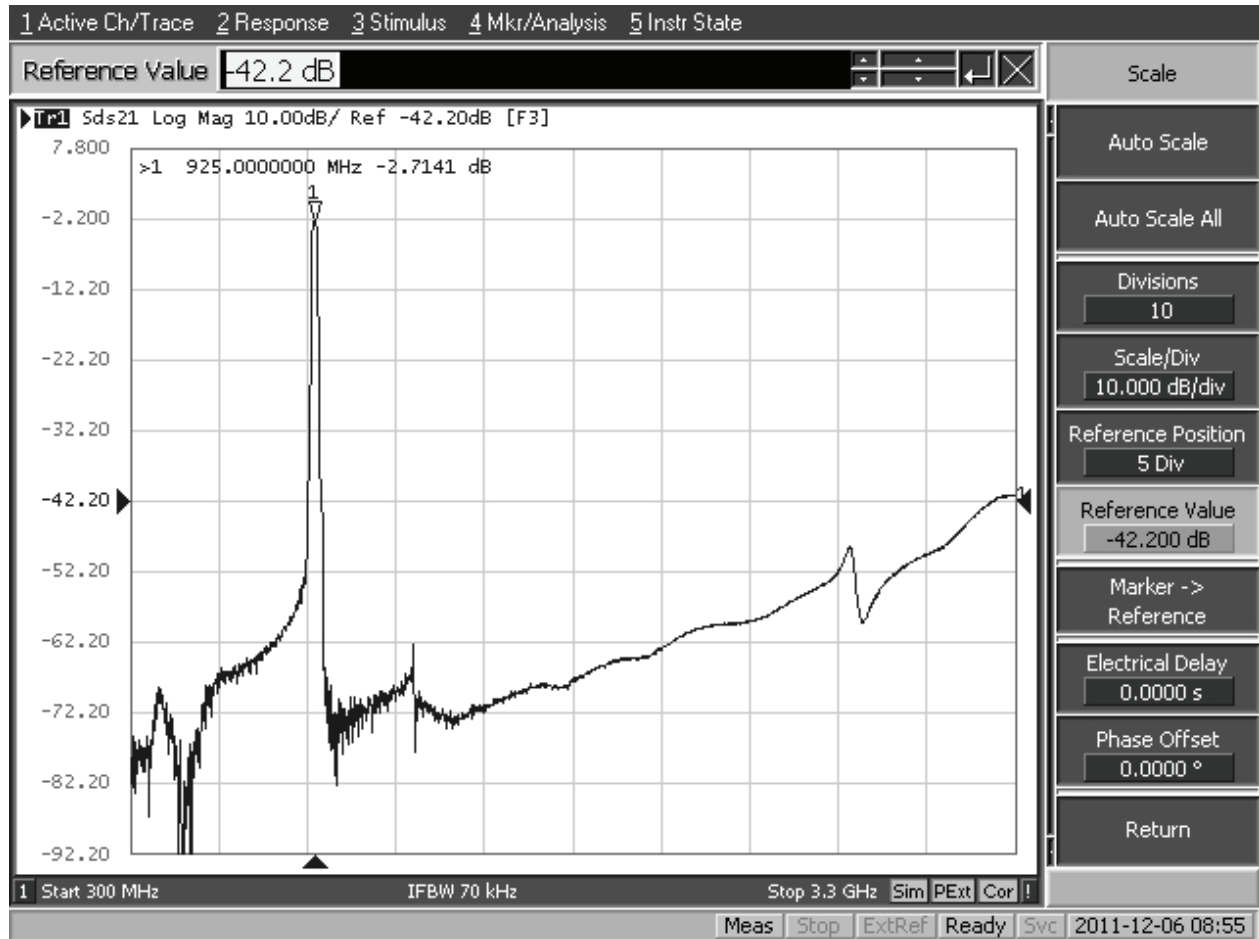

# RF3620E Impedance Plots

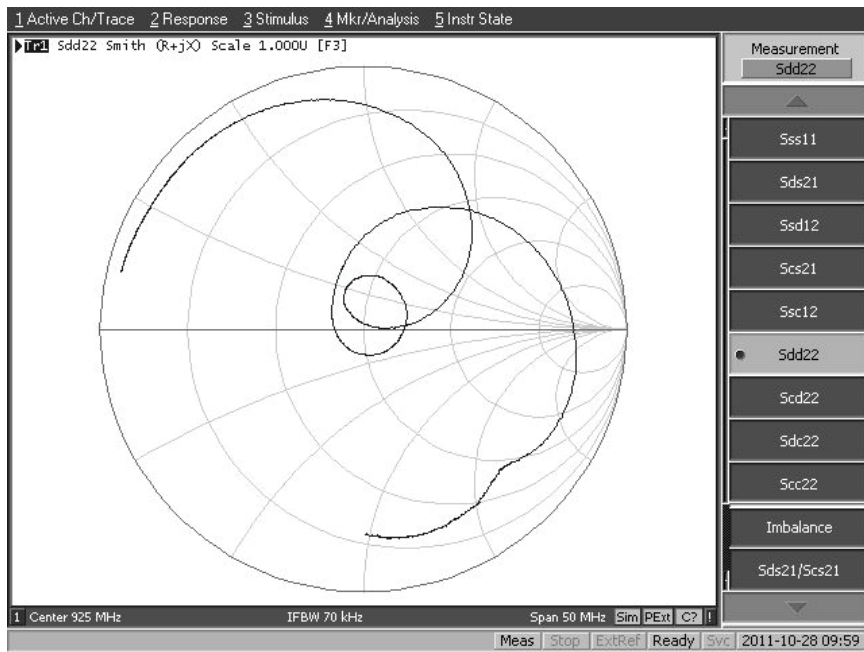
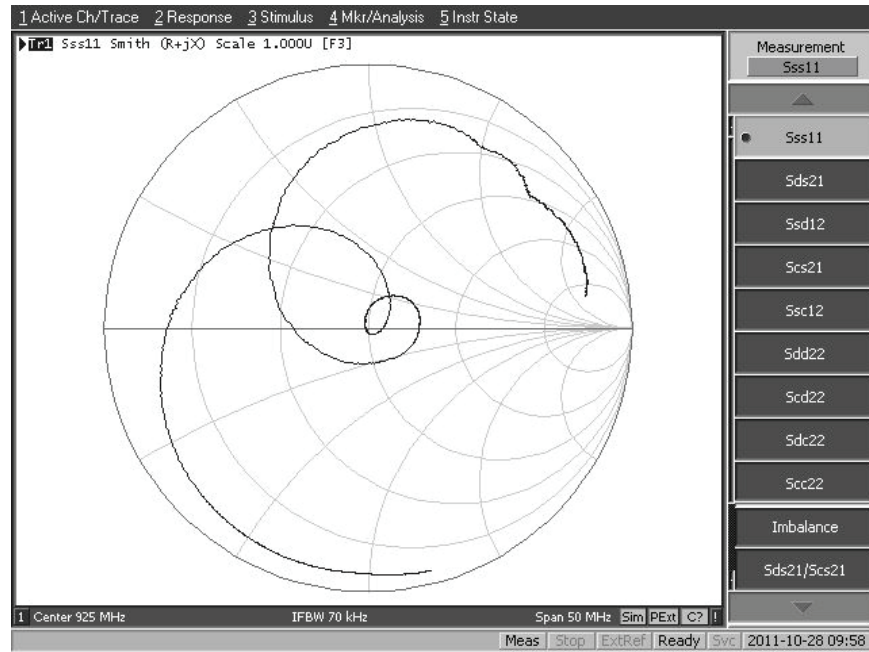

## 8-Terminal Ceramic Surface-Mount Case 3.0 X 3.0 mm Nominal Footprint

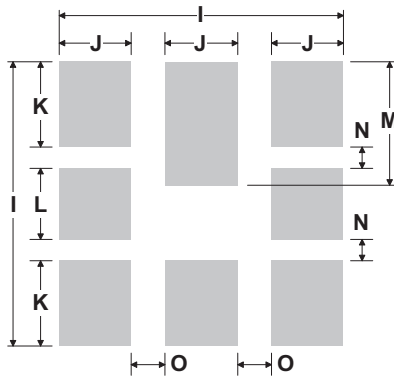
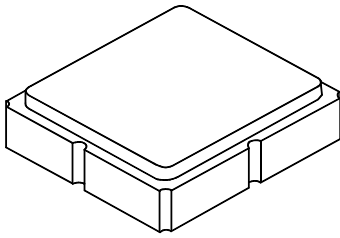

**PCB Footprint Top View**

### Case and PCB Footprint Dimensions

| Dimension | mm   |      |      | Inches |       |       |
|-----------|------|------|------|--------|-------|-------|
|           | Min  | Nom  | Max  | Min    | Nom   | Max   |
| A         | 2.87 | 3.0  | 3.13 | 0.113  | 0.118 | 0.123 |
| B         | 2.87 | 3.0  | 3.13 | 0.113  | 0.118 | 0.123 |
| C         | 1.14 | 1.27 | 1.40 | 0.045  | 0.050 | 0.055 |
| D         | 0.79 | 0.92 | 1.05 | 0.031  | 0.036 | 0.041 |
| E         | 0.62 | 0.75 | 0.88 | 0.024  | 0.029 | 0.034 |
| F         | 0.47 | 0.60 | 0.73 | 0.018  | 0.024 | 0.029 |
| G         | 0.47 | 0.60 | 0.73 | 0.018  | 0.024 | 0.029 |
| H         | 1.07 | 1.20 | 1.33 | 0.042  | 0.047 | 0.052 |
| I         |      | 3.19 |      |        | 0.126 |       |
| J         |      | 0.81 |      |        | 0.032 |       |
| K         |      | 0.96 |      |        | 0.038 |       |
| L         |      | 0.81 |      |        | 0.032 |       |
| M         |      | 1.39 |      |        | 0.055 |       |
| N         |      | 0.23 |      |        | 0.009 |       |
| O         |      | 0.38 |      |        | 0.015 |       |

### Case Materials

| Materials          |  |
|--------------------|--|
| Solder Pad Plating | 0.3 to 1.0 $\mu\text{m}$ Gold over 1.27 to 8.89 $\mu\text{m}$ Nickel |
| Lid Plating        | 2.0 to 3.0 $\mu\text{m}$ Nickel                                      |
| Body               | $\text{Al}_2\text{O}_3$ Ceramic                                      |
|                    | Pb Free  |

**TOP VIEW**

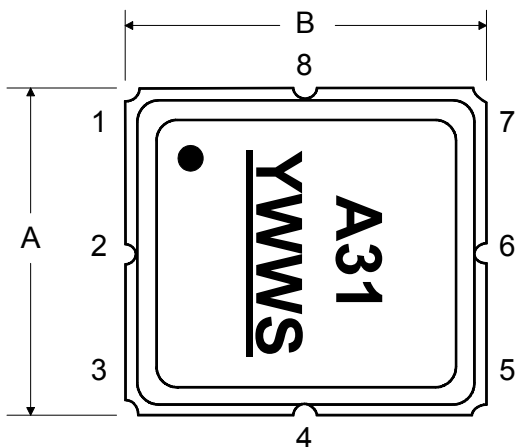

**BOTTOM VIEW**

