

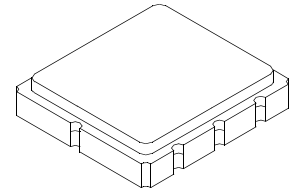

RF3417E

315.00 MHz SAW Filter



SM3030-6 Case
3.0 x 3.0

- **Ideal Front-End Filter for European Wireless Receivers**
- **Low-Loss, Coupled-Resonator Quartz Design**
- **Simple External Impedance Matching**
- **Complies with Directive 2002/95/EC (RoHS)**



The RF3417E is a low-loss, compact, and economical surface-acoustic-wave (SAW) filter designed to provide front-end selectivity in 315.0 MHz receivers. Receiver designs using this filter include superhet with 10.7 MHz or 500 kHz IF, direct conversion and superregen. Typical applications of these receivers are wireless remote-control and security devices operating in Europe under ETSI I-ETS 300 220, in Germany under FTZ 17 TR 2100, in the United Kingdom under DTI MPT 1340 (for automotive only), in France under PTT Specifications ST/PAA/TPA/AGH/1542, and in Scandinavia.

This coupled-resonator filter (CRF) uses selective null placement to provide suppression, typically greater than 40 dB, of the LO and image spurious responses of superhet receivers with 10.7 MHz IF. RFM's advanced SAW design and fabrication technology is utilized to achieve high performance and very low loss with simple external impedance matching (not included).

Electrical Characteristics

Characteristic	Sym	Notes	Minimum	Typical	Maximum	Units	
Center Frequency @ 25°C Absolute Frequency	f_c	1, 2, 3	314.900	315.00	315.100	MHz	
Insertion Loss	IL	1		1.8	2.5	dB	
3 dB Bandwidth	BW ₃	1, 3	525	600	675	kHz	
1 dB Bandwidth	BW ₁	1, 3		450		kHz	
Rejection		1, 3, 10, 11	10 - 275 MHz	40	60		dB
			275 - 306 MHz	40	45		
			306 - 313.2 MHz	25	30		
			313.2 - 314.2 MHz	7	15		
			315.8 - 317 MHz	12	15		
			317 - 321.8 MHz	25	30		
			321.8 - 326 MHz	12	17		
			326 - 355 MHz	37	45		
355 - 1000 MHz	50	55					
Temperature Freq. Temp. Coefficient	FTC	3, 4		0.032		ppm/°C ²	
Turnover Temperature	T _o	3, 4	10		40	°C	
Frequency Aging Absolute Value during the First Year	fA	5		<±10		ppm/yr	
Impedance @ f_c	Input $Z_{IN} = R_{IN}/C_{IN}$	1			3.7kΩ // 2.03pF		
	Output $Z_{OUT} = R_{OUT}/C_{OUT}$				5.4kΩ // 2.17pF		
Lid Symbolization (in addition to Lot and/or Date Codes)	696 // YWWS						
Standard Reel Quantity 7 Inch Reel			9	500 Pieces/Reel			
Standard Reel Quantity 13 Inch Reel				3000 Pieces/Reel			



CAUTION: Electrostatic Sensitive Device. Observe precautions for handling.

Notes:

1. Unless noted otherwise, all measurements are made with the filter installed in the specified test fixture which is connected to a 50 Ω test system with VSWR ≤ 1.2:1. The test fixture L and C are adjusted for minimum insertion loss at the filter center frequency, f_c . Note that insertion loss and bandwidth are dependent on the impedance matching component values and quality.
2. The frequency f_c is defined as the midpoint between the 3dB frequencies.
3. Where noted, specifications apply over the entire specified operating temperature range of -40 to 90°C.
4. The turnover temperature, T_o, is the temperature of maximum (or turnover) frequency, f_o . The nominal frequency at any case temperature, T_c, may be calculated from: $f = f_o [1 - FTC (T_o - T_c)^2]$.
5. Frequency aging is the change in f_c with time and is specified at +65°C or less. Aging may exceed the specification for prolonged temperatures above +65°C. Typically, aging is greatest the first year after manufacture, decreasing significantly in subsequent years.
6. The design, manufacturing process, and specifications of this device are subject to change without notice.
7. One or more of the following U.S. Patents apply: 4,54,488, 4,616,197, and others pending.
8. All equipment designs utilizing this product must be approved by the appropriate government agency prior to manufacture or sale.
9. Tape and Reel Standard for ANSI / EIA 481.
10. These values are attainable by using the optional pin out.
11. Typical rejection is defined as the typical rejection at the worst frequency in the band.

17 Apr 2007 11:50:38

CH1 S11 1 UFS

1: 50.721 Ω 3.2051 Ω 1.6194 nH 315.000 000 MHz

h_p
RF3417E DEMO
FULL 2 PORTS CAL.

Cor

Full

↑

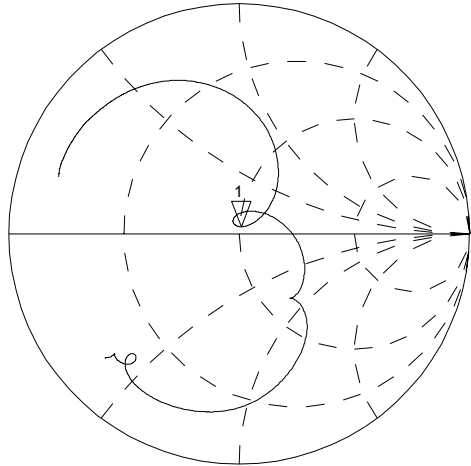

CH2 S22 1 UFS

1: 46.738 Ω -14.436 Ω 35.001 pF 315.000 000 MHz

Cor
Full

↑

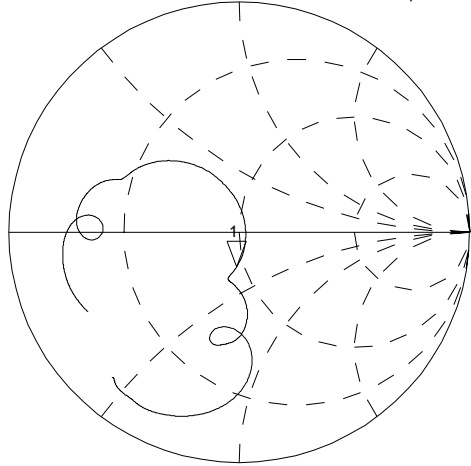

CENTER 315.000 000 MHz

SPAN 2.000 000 MHz

17 Apr 2007 11:50:52

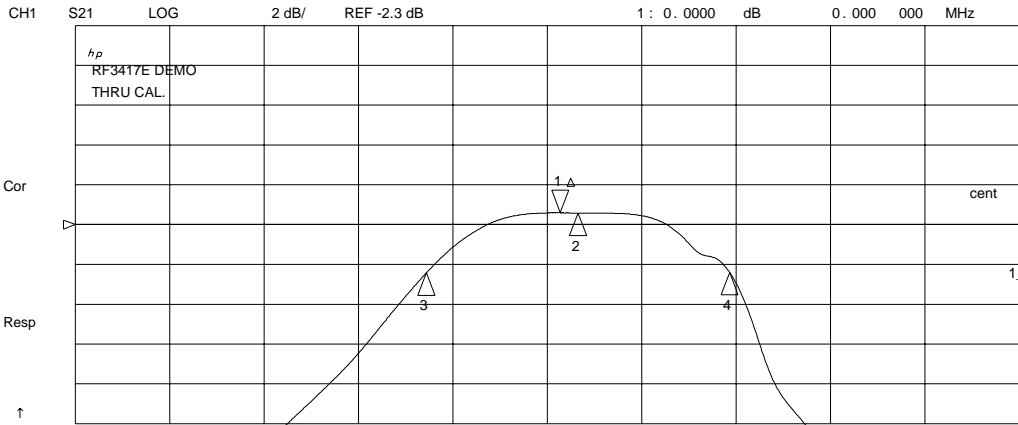

CH1 Markers
 Max Δ REF=1
 BW: .641618 MHz
 : 315.065431 MHz
 Q: 491.05
 1. loss : -1.7003 dB

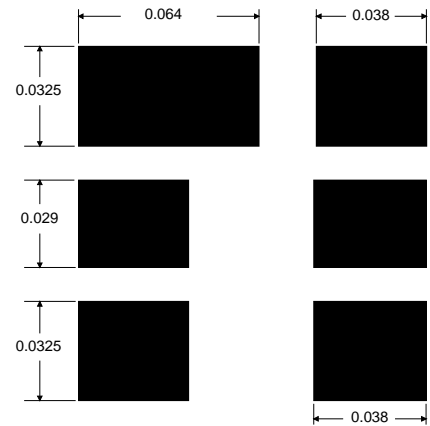
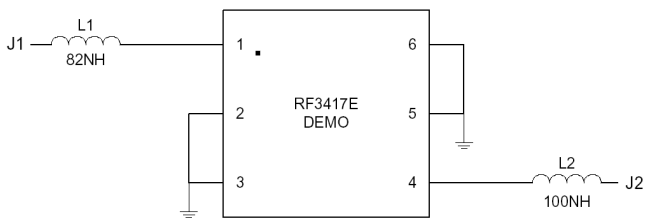
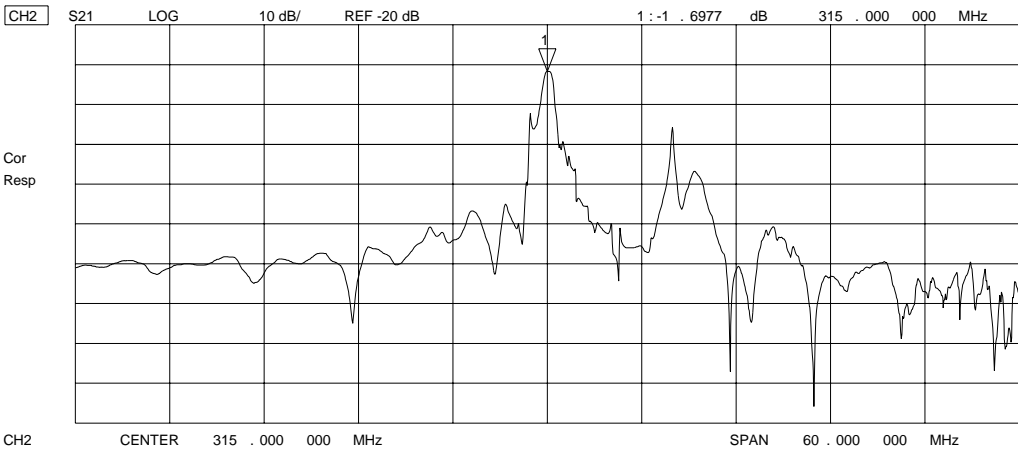

PCB Pad Layout in Inches

Absolute Maximum Ratings

Rating	Value	Units
Input Power Level	10	dBm
DC Voltage	12	VDC
Storage Temperature	-40 to +125	°C
Operable Temperature Range	-40 to +125	°C
Soldering Temperature	(10 seconds / 5 cycles max.)	°C

Electrical Connections

Pin	Connection
1	Input Ground
2	Input
3	Ground
4	Output Ground
5	Output
6	Ground

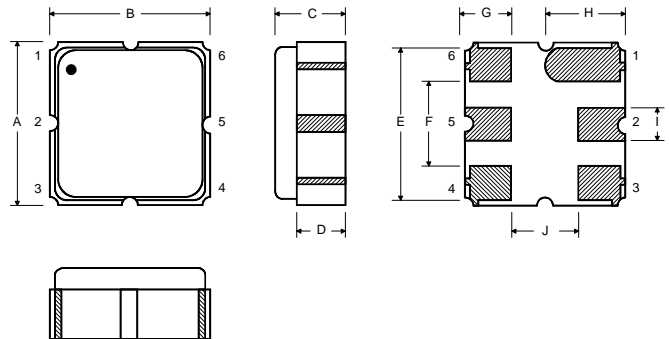

Case Dimensions

Dimension	mm			Inches		
	Min	Nom	Max	Min	Nom	Max
A	2.87	3.0	3.13	0.113	0.118	0.123
B	2.87	3.0	3.13	0.113	0.118	0.123
C	1.12	1.25	1.38	0.044	0.049	0.054
D	0.77	0.90	1.03	0.030	0.035	0.040
E	2.67	2.80	2.93	0.105	0.110	0.115
F	1.47	1.6	1.73	0.058	0.063	0.068
G	0.72	0.85	0.98	0.028	0.033	0.038
H	1.37	1.5	1.63	0.054	0.059	0.064
I	0.47	0.60	0.73	0.019	0.024	0.029
J	1.17	1.30	1.43	0.046	0.051	0.056

Matching Circuit to 50Ω

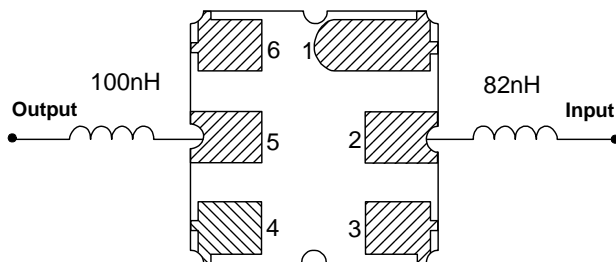

Optional Electrical Connections

Pin	Connection
1	Input
2	Input Ground
3	Ground
4	Output
5	Output Ground
6	Ground

Matching Circuit to 50Ω

