

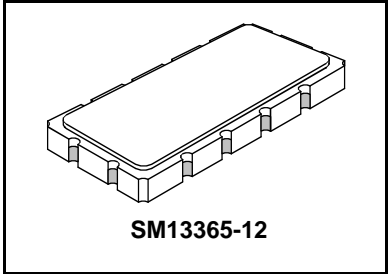

# Preliminary

**SF2227A**

**70 MHz  
SAW Filter**



- Precision IF SAW Filter
- Hermetic 13.3 x 6.5 mm Surface-mount Case
- Complies with Directive 2002/95/EC (RoHS)



### Absolute Maximum Ratings

Rating	Value	Units
Maximum Incident Power in Passband	+20	dBm
Maximum DC Voltage on any Non-ground Terminal	30	VDC
Storage Temperature Range in Tape and Reel	-40 to +85	°C
Suitable for Lead-free Soldering - Maximum Soldering Profile	260 °C for 30 s	

### Electrical Characteristics

Characteristic	Sym	Notes	Min	Typ	Max	Units
Center Frequency	$f_C$	1	69.8	70.0	70.2	MHz
1 dB Bandwidth	$BW_1$	1	5.2	5.4		
3 dB Bandwidth	$BW_3$	1	6.0	6.5		
40 dB Bandwidth	$BW_{40}$	1		9.5	10	
Insertion Loss	IL	1		7.6	9.0	dB
Amplitude Ripple, $f_C \pm 2.1$ MHz		1, 2, 3		0.8	1.0	dB <sub>p-p</sub>
Group Delay Ripple, $f_C \pm 2.1$ MHz				140	170	ns <sub>p-p</sub>
Relative Attenuation:						dB
10 to 64.5 MHz			40	45		
75.5 to 140 MHz			40	43		
Operating Temperature Range		1	-30		+80	°C
Frequency Temperature Coefficient				-94		ppm/°C

Impedance Matching to 50 Ω Unbalanced	External L-C
Case Style	SM13365-12 13.3 x 6.5 mm Nominal Footprint
Lid Symbolization (YY = year, WW = week)	RFM SF2227A YYWW



**CAUTION: Electrostatic Sensitive Device. Observe precautions for handling.**

### Notes:

1. Unless noted otherwise, all specifications apply over the operating temperature range with filter soldered to the specified demonstration board with impedance matching to 50 Ω and measured with 50 Ω network analyzer.
2. Unless noted otherwise, all frequency specifications are referenced to the nominal center frequency,  $f_C$ .
3. Rejection is measured as attenuation below the minimum IL point in the passband. Rejection in final user application is dependent on PCB layout and external impedance matching design. See Application Note No. 42 for details.
4. Part to part absolute delay measurement records the absolute delay mean across 1 dB passband.
5. "LRIP" or "L" after the part number indicates "low rate initial production" and "ENG" or "E" indicates "engineering prototypes."
6. The design, manufacturing process, and specifications of this filter are subject to change.
7. Either Port 1 or Port 2 may be used for either input or output in the design. However, impedances and impedance matching may vary between Port 1 and Port 2, so that the filter must always be installed in one direction per the circuit design.
8. US and international patents may apply.

# Filter Response Plots

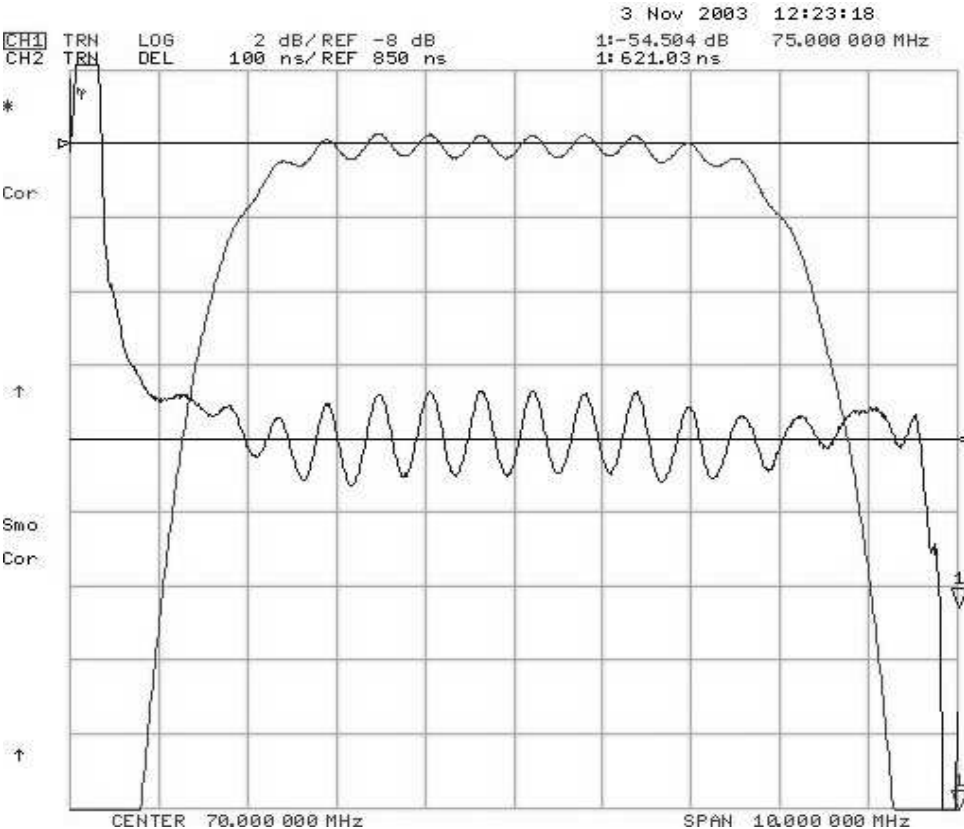
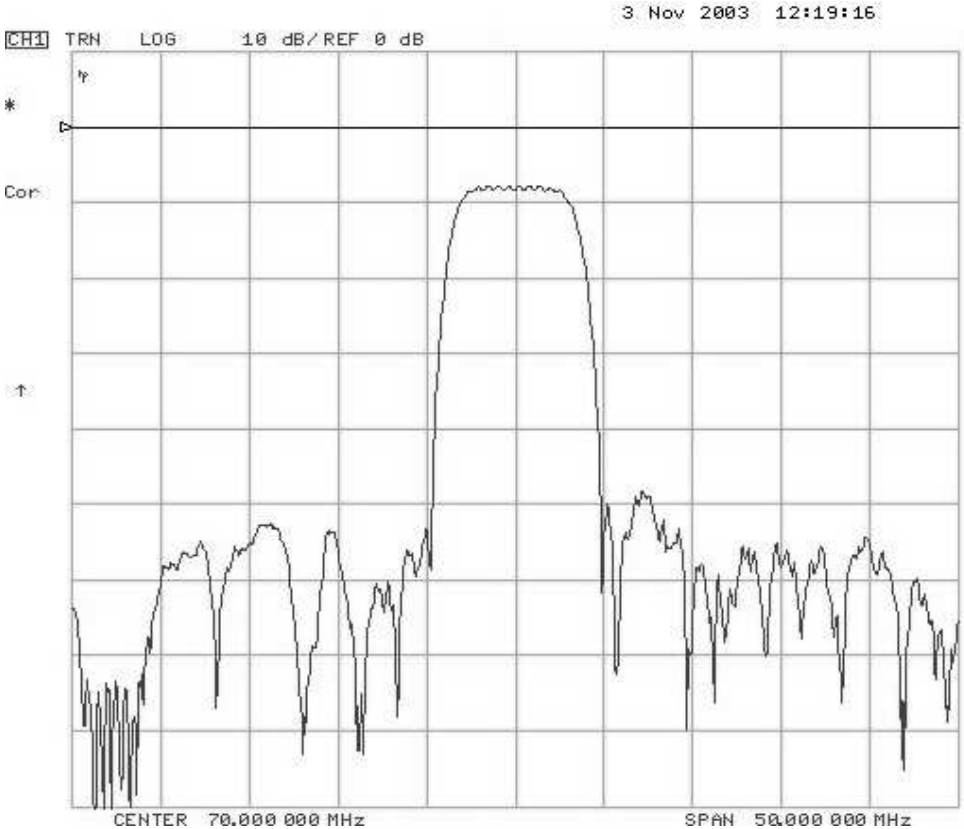



# SM13365-12 Ceramic Surface-mount 12-Terminal Case

## 13.3 x 6.5 mm Nominal Footprint

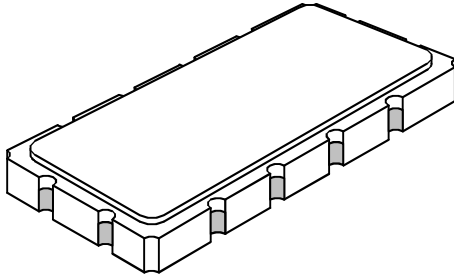

### Electrical Connections

Connection	Terminals
Input	11
Output	5
Case Ground	All others

### Case Dimensions

Dimension	mm			Inches		
	Min	Nom	Max	Min	Nom	Max
A	13.10	13.30	13.50	0.516	0.524	0.531
B	6.30	6.50	6.70	0.248	0.256	0.264
C			1.80			0.071
D		1.50			0.059	
E		0.80			0.031	
H		0.80			0.031	
P		2.54			0.100	

### Case Material

Materials	
Solder Pad Plating	0.3 to 1.0 $\mu\text{m}$ Gold over 1.27 to 8.89 $\mu\text{m}$ Nickel
Lid Plating	2.0 to 3.0 $\mu\text{m}$ Nickel
Body	$\text{Al}_2\text{O}_3$ Ceramic
Pb Free	

### Case Outline Drawing

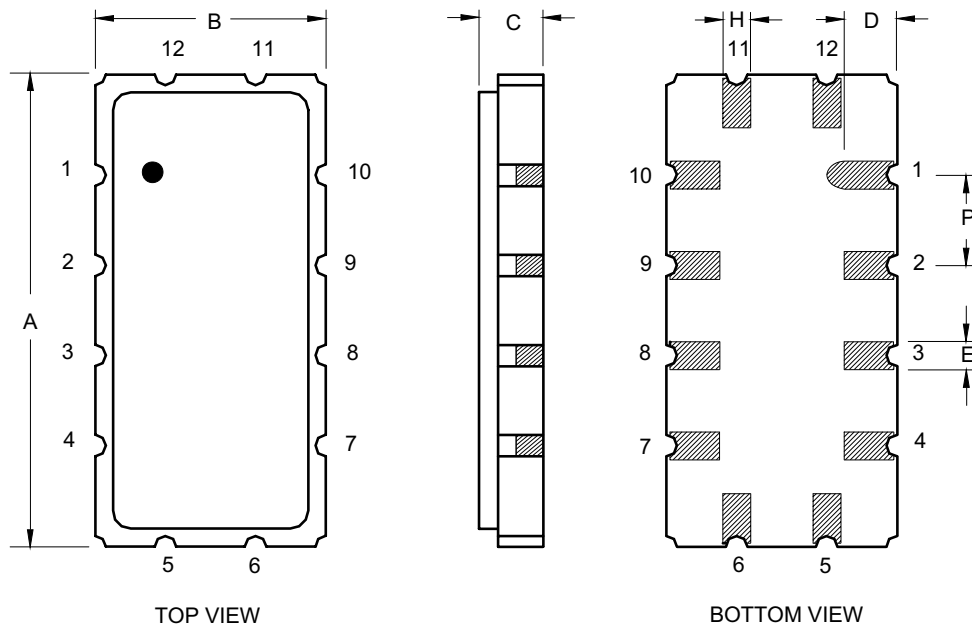

# Tape and Reel Details

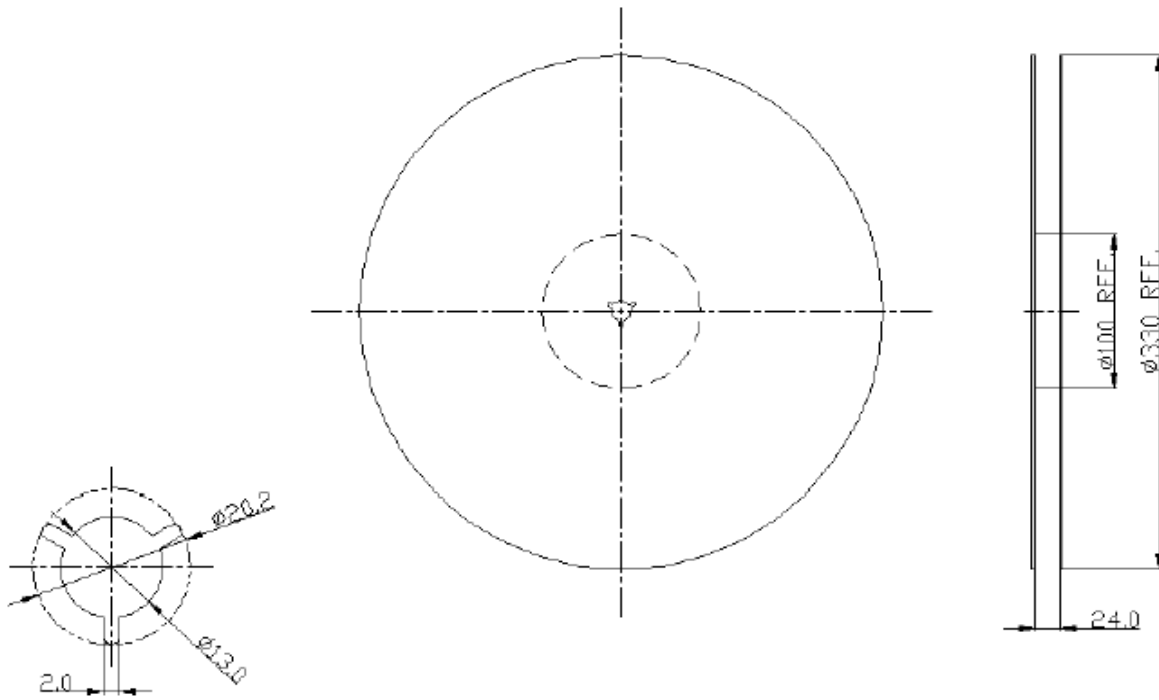

## 13.3X6.5

