



SF2079D

- **Low Insertion Loss**
- **3.8 X 3.8 mm Surface-Mount Case**
- **Single Ended Input and Output**
- **Complies with Directive 2002/95/EC (RoHS)**



**251.045 MHz
SAW Filter**

Absolute Maximum Ratings

Rating	Value	Units
Maximum Incident Power in Passband	+13	dBm
Max. DC voltage between any 2 terminals	30	VDC
Storage Temperature Range	-40 to +85	°C
Suitable for lead-free soldering - Max Soldering Temperature	260 °C for 30 s	

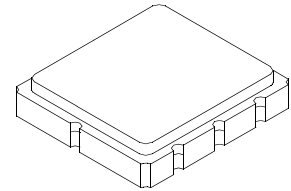

SM3838-8

Electrical Characteristics

Characteristic	Sym	Notes	Min	Typ	Max	Units
Nominal Center Frequency	f_c	1		251.045		MHz
Insertion Loss		1		15.5	17.5	dB
Amplitude Ripple (p-p)		Fc-6.250 to Fc-4.3925 MHz		0.7	1.5	dB
		Fc-4.3925 to Fc-2.535 MHz		0.5	1.5	dB
		Fc-2.5350 to Fc-0.025 MHz		0.8	1.5	dB
		Fc+0.025 to Fc+2.535 MHz		0.9	1.5	dB
		Fc+2.5350 to Fc+4.3925 MHz		0.5	1.5	dB
		Fc+4.3925 to Fc+6.250 MHz		0.6	1.5	dB
Pass bandwidth of -1.5dB				13.9		MHz
Pass bandwidth of -3dB				14.5		MHz
Low side attenuation $F_c < (F_c - 16.5 \text{ MHz})$			33	37		dB
Low side attenuation between: $(F_c - 16.5 \text{ MHz}) \dots (F_c - 10.5 \text{ MHz})$			28	32		dB
High side attenuation between: $(F_c + 9.0 \text{ MHz}) \dots (F_c + 16.5 \text{ MHz})$			24	30		dB
High side attenuation $F_c > (F_c + 16.5 \text{ MHz})$			35	40		dB
Temperature Coefficient of frequency					-18	ppm/K
Delay Ripple (p-p)		Fc-6.250 to Fc-4.3925 MHz		45	70	ns
		Fc-4.3925 to Fc-2.535 MHz		25	70	ns
		Fc-2.5350 to Fc-0.025 MHz		20	90	ns
		Fc+0.025 to Fc+2.535 MHz		15	90	ns
		Fc+2.5350 to Fc+4.3925 MHz		25	70	ns
		Fc+4.3925 to Fc+6.250 MHz		45	90	ns
Terminating Source / Load Impedance: Z_{IN} / Z_{OUT}				150		Ohms
Operating Temperature Range			-40		+85	°C
Case Style			SM3838-8 3.8 x 3.8 mm Nominal Footprint			
Lid Symbolization (Y=year, WW=week, S=shift)			RFM TBD YWWS			

Notes:

1. Unless noted otherwise, all specifications apply over the operating temperature range with filter soldered to the specified demonstration board with impedance matching to 50 Ω and measured with 50 Ω network analyzer.
2. Rejection is measured as attenuation below the minimum IL point in the passband. Rejection in final user application is dependent on PCB layout and external impedance matching design. See Application Note No. 42 for details.
3. The design, manufacturing process, and specifications of this filter are subject to change.
4. Tape and Reel Standard ANSI / EIA 481.
5. Either Port 1 or Port 2 may be used for either input or output in the design. However, impedances and impedance matching may vary between Port 1 and Port 2, so that the filter must always be installed in one direction per the circuit design.
6. US and international patents may apply.
7. RFM, stylized RFM logo, and RF Monolithics, Inc. are registered trademarks of RF Monolithics, Inc.
8. ©Copyright 1999, RF Monolithics Inc.
9. Electrostatic Sensitive Device. Observe precautions for handling. 

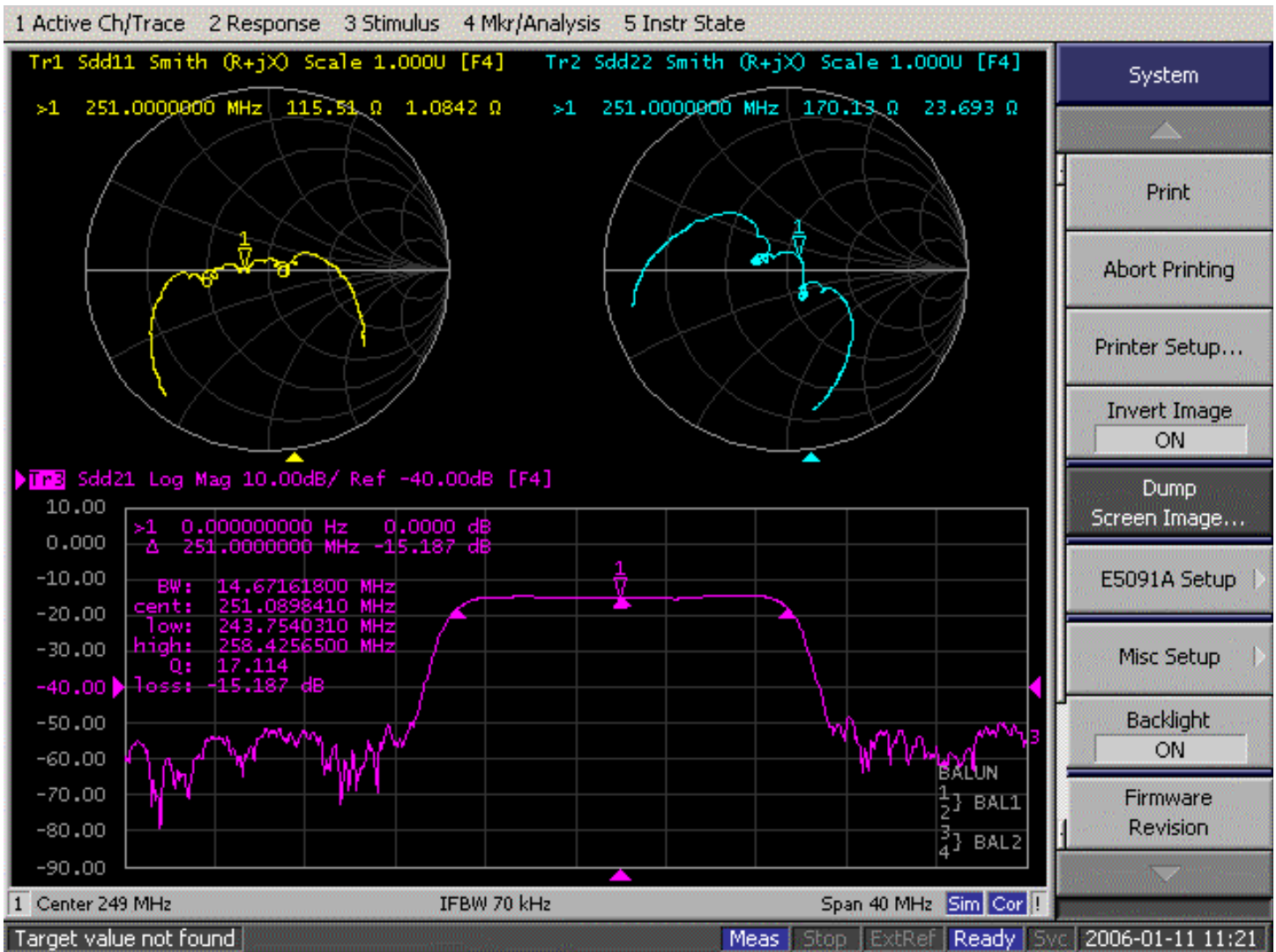
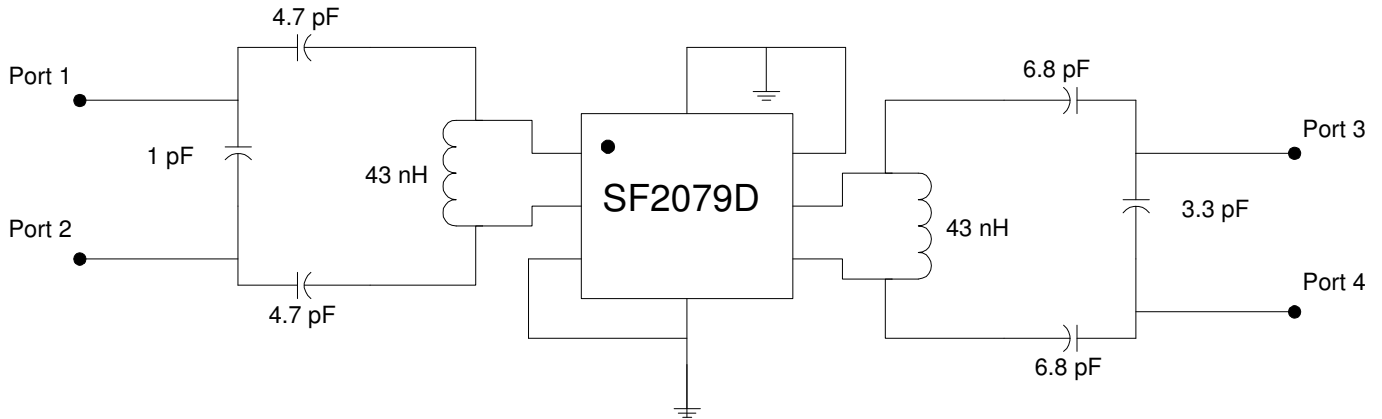

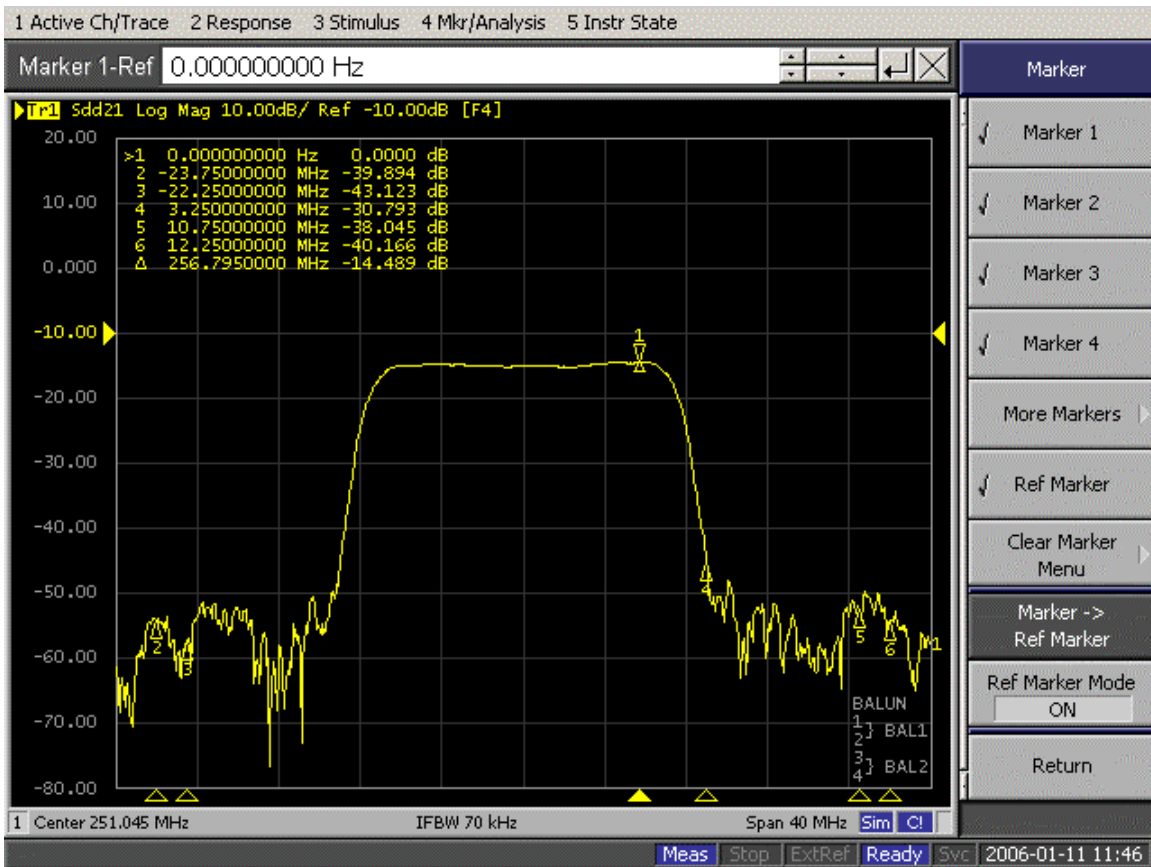
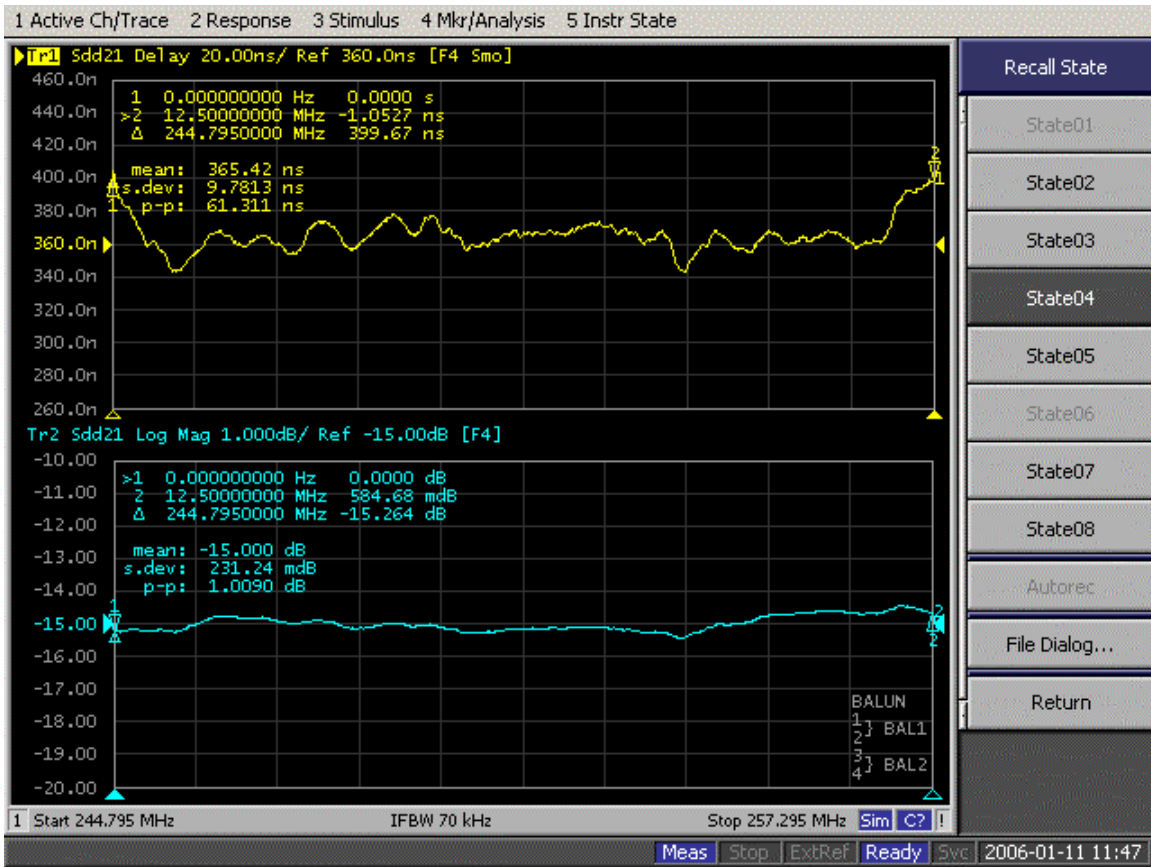

SM3838-8 Case

8-Terminal Ceramic Surface-Mount Case
3.8 X 3.8 mm Nominal Footprint

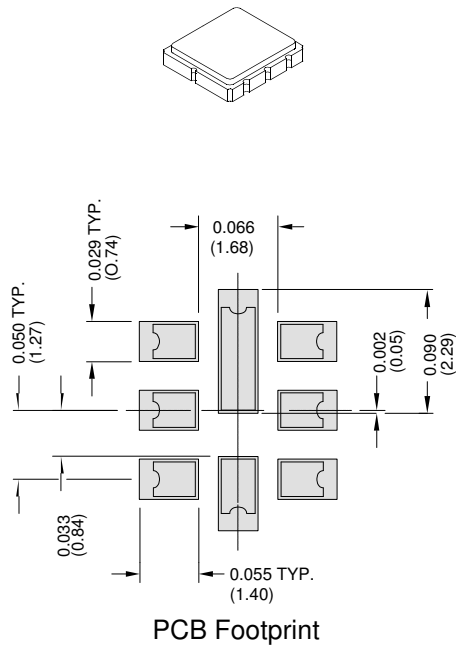

Case Dimensions						
Dimension	mm			Inches		
	Min	Nom	Max	Min	Nom	Max
A	3.6	3.8	4.0	0.142	0.150	0.157
B	3.6	3.8	4.0	0.142	0.150	0.157
C	0.95	1.10	1.25	0.037	0.043	0.049
D	0.60	0.85	1.00	0.023	0.033	0.039
E	0.90	1.00	1.10	0.035	0.040	0.043
F	0.50	0.60	0.70	0.020	0.024	0.028
G	2.39	2.54	2.69	0.090	0.100	0.110
H	1.35	1.5	1.65	0.053	0.059	0.065

Electrical Connections		
	Connection	Terminals
Port 1	Differential Input	1, 2
Port 2	Differential Output	5, 6
	Ground	All Others
Single Ended Operation		Return is Ground
Differential Operation		Return is Hot
Dot Indicates Pin 1		

Materials	
Solder Pad Termination	Au plating 30 - 60 ulnches (76.2-152 uM) over 80-200 ulnches (203-508 uM) Ni.
Lid	Fe-Ni-Co Alloy Electroless Nickel Plate (8-11% Phosphorus) 100-200 ulnches Thick
Body	Al ₂ O ₃ Ceramic
Pb Free	

TOP VIEW

BOTTOM VIEW

