

# Preliminary

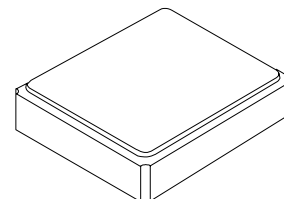

**XTC7009G**

**16.36800 MHz  
TCXO**



**4-Terminal SMD Case**

- **Temperature Compensated Crystal Oscillator**
- **Ultra-miniature 2.5 x 2.0 x 0.8 mm Package**
- **Excellent Frequency Stability**
- **Low Phase Noise**
- **Complies with Directive 2002/95/EC (RoHS)**



## Electrical Characteristics

Characteristic	Sym	Notes	Minimum	Typical	Maximum	Units
Nominal Frequency	F <sub>O</sub>			16.36800		MHz
Frequency Tolerance after Reflow			±2 ppm maximum @ 25 ±3 °C			
Storage Temperature Range in Tape and Reel			-40		+85	°C
Operating Temperature Range			-40		+85	°C
Power Supply Voltage Range	V <sub>CC</sub>		2.70	2.85	3.00	V
Output Voltage with 10 pF    10 KΩ Load			0.8			V <sub>P-P</sub>
Output Waveform			Clipped Sinewave			
Duty Cycle			40		60	%
Power Supply Current	I <sub>CC</sub>				1.5	mA
Frequency Stability versus:						
Temperature, -30 to 85 °C					±0.5	ppm
Temperature, -40 to 30 °C					±2.0	ppm
Load Variation, 10 pF    10 KΩ ±10%					±0.2	ppm
Supply Voltage, 2.85 V ±5%					±0.2	ppm
Frequency Step, df/f					±2.5	ppb
Short Term Drift, df/f/s					±2.5	ppb/s
Start Up Time, 90% of Final RF Level in V <sub>P-P</sub>					2.0	ms
Harmonics					-5.0	dBc
Frequency Slope, measured at least every 2 °C, -30 to +85 °C					±0.1	ppm/°C
Static Temperature Hysteresis					±0.6	ppm
SSB Phase Noise @ 0.1 Hz Carrier Offset					-23	dBc/Hz
SSB Phase Noise @ 1 Hz Carrier Offset					-53	dBc/Hz
SSB Phase Noise @ 10 Hz Carrier Offset					-78	dBc/Hz
SSB Phase Noise @ 100 Hz Carrier Offset					-93	dBc/Hz
SSB Phase Noise @ 1 kHz Carrier Offset					-103	dBc/Hz
SSB Phase Noise @ 10 kHz Carrier Offset					-108	dBc/Hz
G Sensitivity, 3 axes, 30 to 1500 Hz, +25 °C, V <sub>DD</sub> = 3V					2	ppb/G
Aging @ 25 °C					±1.0	ppm/yr
Standard Shipping Quantity on 180 mm (7") Reel				1000		units
Lid Symbolization				3S		

## Notes:

1. The design, manufacturing process, and specifications of this device are subject to change without notice.
2. CAUTION: Electrostatic sensitive device. Observe handling precautions.



# 4 Terminal Surface Mount Seam Welded Case

## 2.5 x 2.0 mm Nominal Footprint

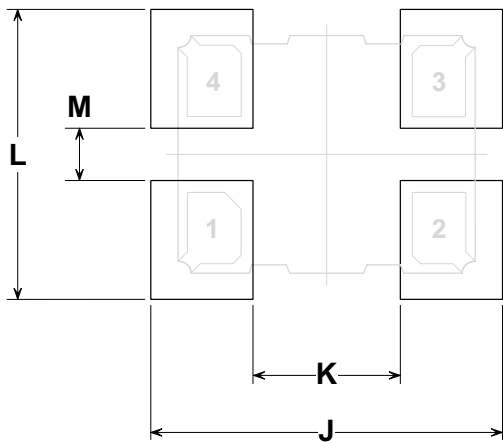
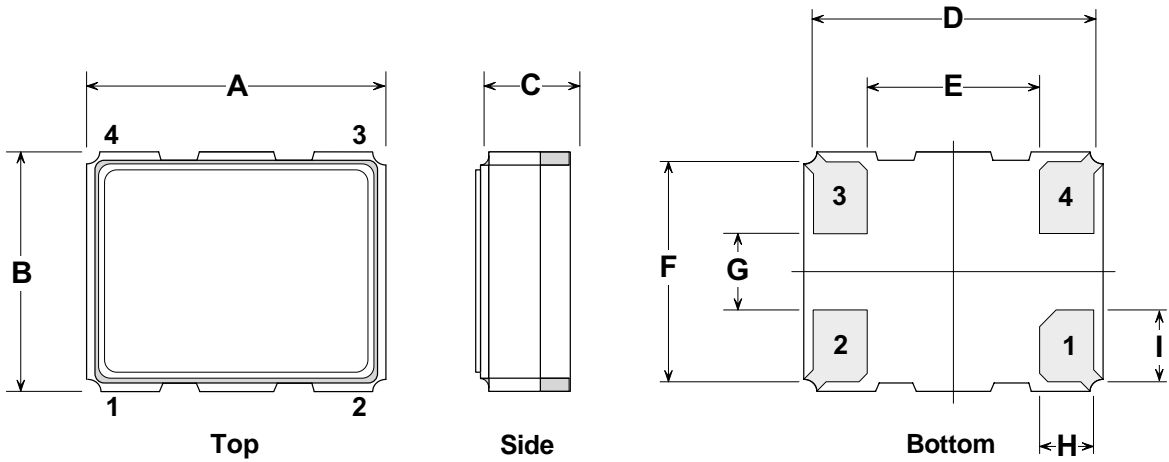

PCB Land Pattern  
(Top View)

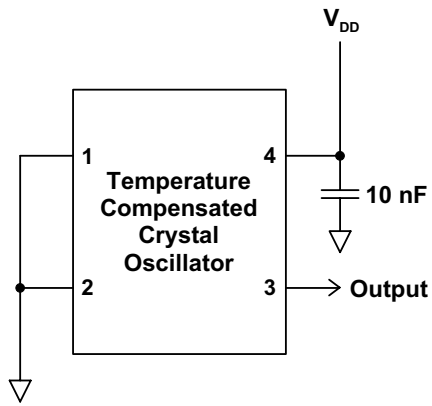

TCXO Application Circuit

### Case and PCB Land Dimensions

Dimension	mm			Inches		
	Min	Nom	Max	Min	Nom	Max
A	2.30	2.50	2.70	0.091	0.098	0.106
B	1.80	2.00	2.20	0.071	0.079	0.087
C	-	-	0.80	-	-	0.031
D	-	2.39	-	-	0.094	-
E	-	1.45	-	-	0.057	-
F	-	1.89	-	-	0.074	-
G	-	0.65	-	-	0.026	-
H	-	0.47	-	-	0.019	-
I	-	0.62	-	-	0.024	-
J	-	2.97	-	-	0.117	-
K	-	1.25	-	-	0.049	-
L	-	2.45	-	-	0.096	-
M	-	0.45	-	-	0.018	-

### Case Materials

Materials	
Solder Pad Plating	0.3 to 1.0 $\mu\text{m}$ Gold over 1.27 to 8.89 $\mu\text{m}$ Nickel
Lid Plating	2.0 to 3.0 $\mu\text{m}$ Nickel
Body	$\text{Al}_2\text{O}_3$ Ceramic
Pb Free	

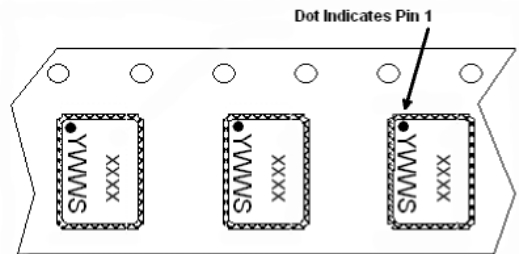

Package Orientation in Carrier Tape

## Terminal Connections

Connection	Terminals
Ground	1
Ground	2
TCXO Output	3
V <sub>DD</sub>	4

## Reel Dimensions

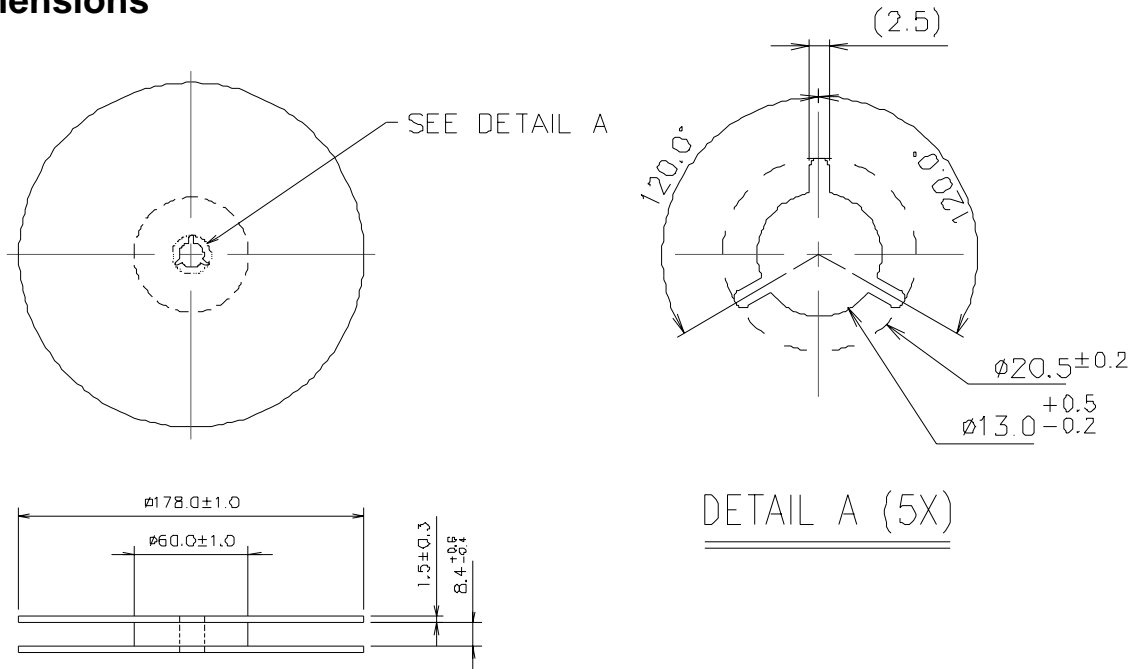

## Tape Dimensions

