

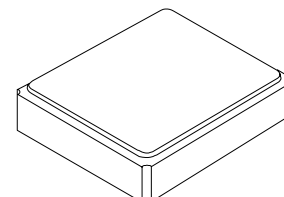

Preliminary

XVT9012

**19.200000 MHz
VCTCXO**



SM3225-4 Case

- **Voltage Controlled Temperature Compensated Crystal Oscillator**
- **Excellent Frequency Stability & Low Phase Noise**
- **3.2 x 2.5 x 1.2 mm Surface-mount Case**
- **Complies with Directive 2002/95/EC (RoHS)** 

Electrical Characteristics

Characteristic	Sym	Notes	Minimum	Typical	Maximum	Units
Nominal Frequency	f _o			19.200000		MHz
Component Storage Temperature Range			-30		+85	°C
Storage Temperature Range in Tape and Reel			-30		+85	°C
Soldering Profile, 10 seconds, up to 5 cycles					260	°C
Operating Temperature Range			-20		+70	°C
Power Supply Voltage	V _{cc}		3.14	3.30	3.46	V
Output Voltage with Load 10 pF 10 KΩ	V _{out}		0.8			V _{P-P}
Output Waveform			clipped sinewave			
Power Supply Current	I _{cc}				2.0	mA
Control Voltage	V _{con}		0.5		2.5	V
Control Voltage Input Impedance			100K			ohms
Frequency Tolerance, Single Solder Reflow, V _{control} = 1.50 V			±2.0 ppm max @ 25 °C ±2 °C			
Frequency Stability versus:						
Temperature, -20 to 70 °C				±1.0		ppm
Supply Voltage, 3.14 to 3.46 V				±0.2		ppm
Load 10 pF 10 KΩ ±10%				±0.2		ppm
Control Voltage Frequency Range, 0.5 to 2.5 V			±13		±17	ppm/V
Start Up Time, 90% of final RF level in V _{P-P}					5.0	ms
Aging @ 25 °C				±1		ppm/year
Harmonics					-5.0	dBc
SSB Phase Noise @ 1 kHz Carrier Offset					-130	dBc/Hz
Lid Symbolization			9012/YWWS			



CAUTION: Electrostatic Sensitive Device. Observe precautions for handling.

Notes:

1. The design, manufacturing process, and specifications of this device are subject to change without notice.

SM3225-4 Case

4-Terminal Surface-Mount Seam Weld Case 3.2 x 2.5 mm Nominal Footprint

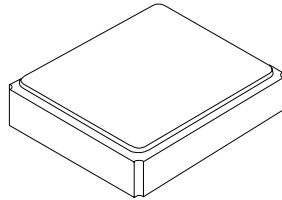

Top View

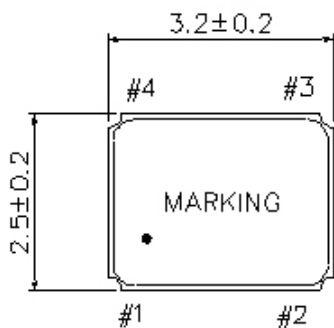

Side View

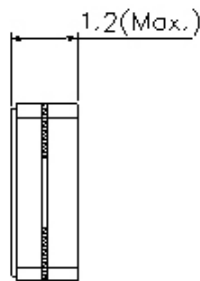

Recommended Land Pattern
(Top View)

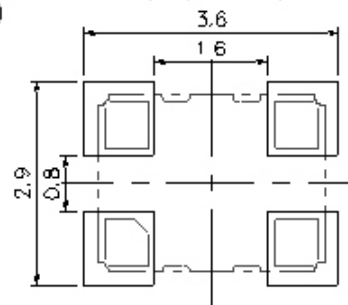

Unit : mm

Bottom View

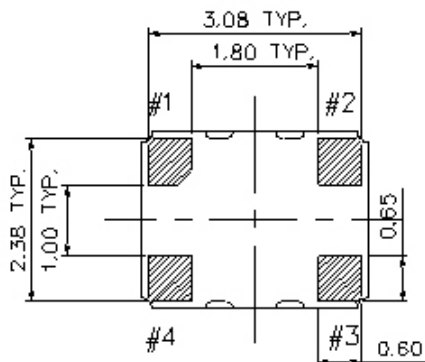

Pin	Connection
1	Vcon
2	GND/CASE GND
3	Output
4	Vcc

Application Circuit

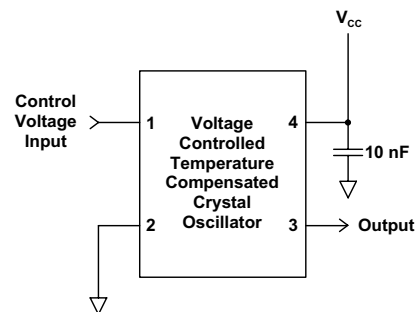

Reel Dimensions

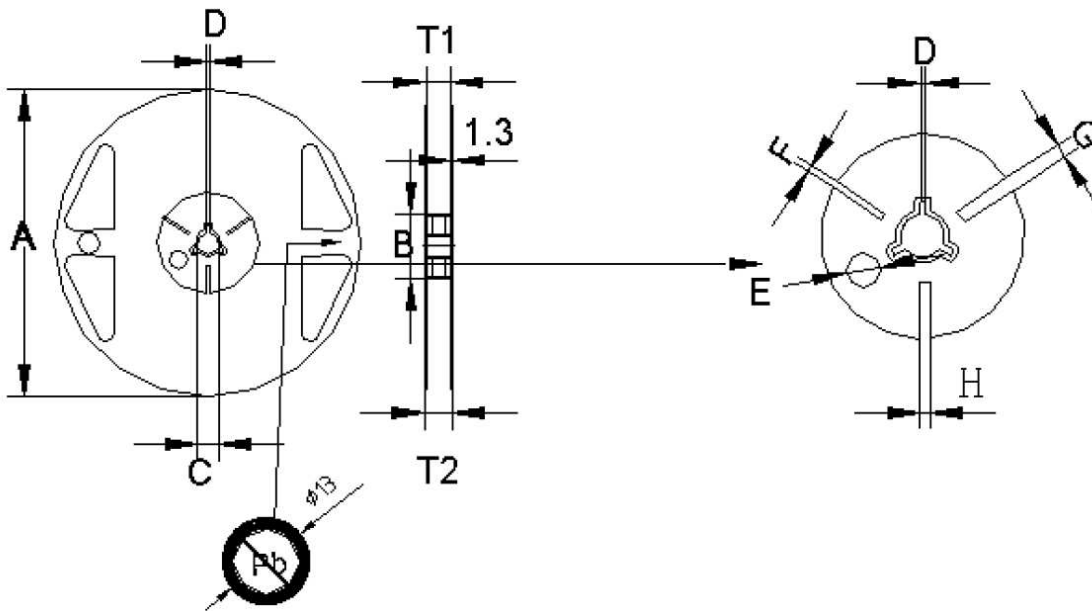

mm	A	B	C	D	E	F	G	H	T1	T2	T3
Dimension	180	60	13.0	2.0	9.1	2.9	4.9	3.9	9.0	11.4	1.2
Tolerance	± 1.0	$+1.0/-0.0$	± 0.2	± 0.5	± 0.5	± 0.5	± 0.5	± 0.5	± 0.3	± 1.0	± 0.1

Tape Dimensions

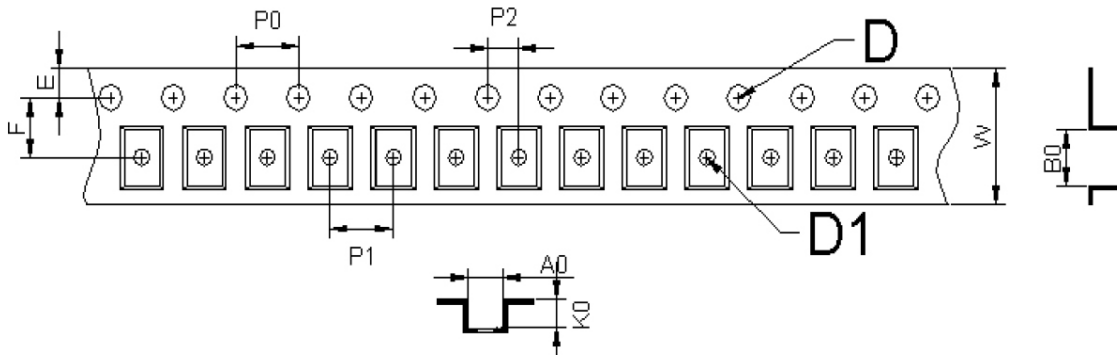

mm	A0	B0	W	F	E	P0	P1	P2	D1	D	K0	t
Dimension	2.80	3.71	8.00	3.50	1.75	4.00	4.00	2.00	1.50	1.00	1.75	0.25
Tolerance	± 0.10	± 0.10	$+0.30/-0.10$	± 0.05	± 0.10	± 0.10	± 0.10	± 0.05	$+0.10/-0.00$	$+0.25/-0.00$	± 0.10	± 0.02