

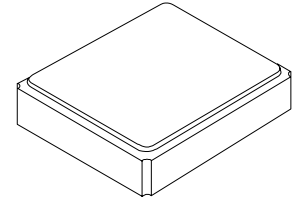

# Preliminary

**XVT9007**

**19.6608 MHz  
VCTCXO**



**SM3225-4 Case**

- Voltage Controlled Temperature Compensated Crystal Oscillator
- Excellent Frequency Stability & Low Phase Noise
- 3.2 x 2.5 x 1.3 mm Surface-Mount Case
- Complies with Directive 2002/95/EC (RoHS)



## Electrical Characteristics

Characteristic	Sym	Notes	Minimum	Typical	Maximum	Units
Nominal Frequency	Fo			19.660800		MHz
Storage Temperature			-40		+85	°C
Operating Temperature Range			-20		+75	°C
Power Supply Voltage	Vcc		2.66	2.8	2.94	V
Output Voltage with Load 10 pF  10 KΩ	Vout		0.8			V <sub>P-P</sub>
Output Wave form			clipped sinewave			
Power Supply Current	Icc				2.0	mA
Control Voltage	Vcon			1.4±1.0		V
Control Voltage Input Impedance			100K			ohms
Frequency Tolerance, Vcontrol = 1.4 V (after Reflow)			±2 ppm max @ 25 °C ±3 °C			
Frequency Stability versus:						
Temperature, -20 to 75 °C				±2.5		ppm
Supply Voltage, 2.66 to 2.94 V				±0.2		ppm
Load 10 pF  10 KΩ ±10%				±0.2		ppm
Control Voltage Frequency Range (1.4 ±1.0 V)			±8		±14	ppm
Start Up Time, 90% of final RF level in V <sub>P-P</sub>					2.0	ms
Aging @ 25 °C				±1		ppm/year
Harmonics					-5.0	dBc
SSB Phase Noise @ 1 kHz Carrier Offset			-130 dBc/Hz maximum			
Standard Shipping Quantity on 180 mm (7") Reel				1000		units
Lid Symbolization			9007 // YWWS			



**CAUTION: Electrostatic Sensitive Device. Observe precautions for handling.**

### Notes:

1. The design, manufacturing process, and specifications of this device are subject to change without notice.

# SM3225-4 Case

## 4-Terminal Surface-Mount Seam Weld Case 3.2 x 2.5 mm Nominal Footprint

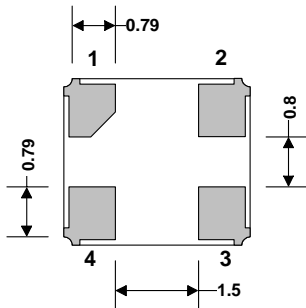
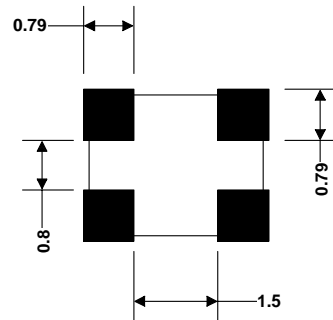
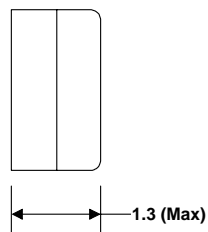
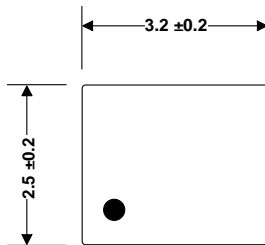
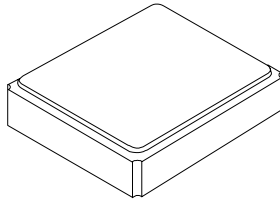

Dimensions in mm

Pin	Connection
1	Vcon
2	GND/CASE GND
3	Output
4	Vcc

### Application Circuit

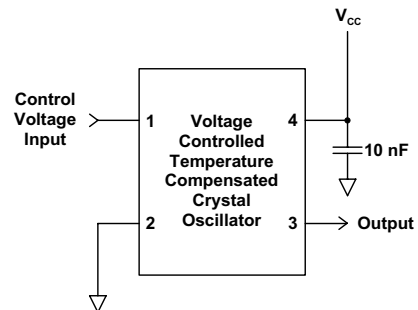

## Reel Dimensions

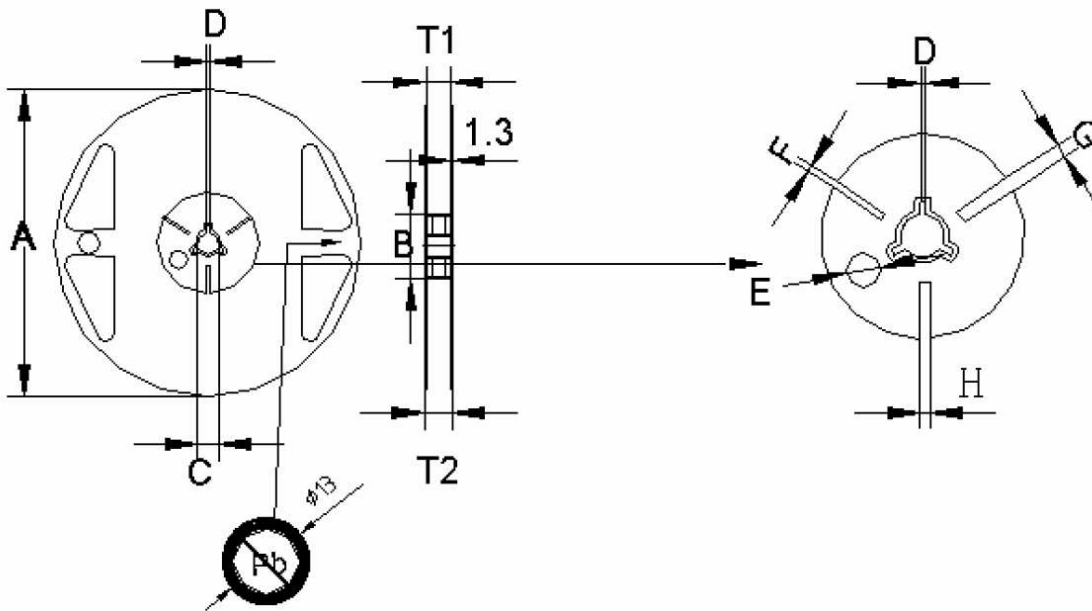

mm	A	B	C	D	E	F	G	H	T1	T2	T3
Dimension	180	60	13.0	2.0	9.1	2.9	4.9	3.9	9.0	11.4	1.2
Tolerance	±1.0	+1.0/-0.0	±0.2	±0.5	±0.5	±0.5	±0.5	±0.5	±0.3	±1.0	±0.1

## Tape Dimensions

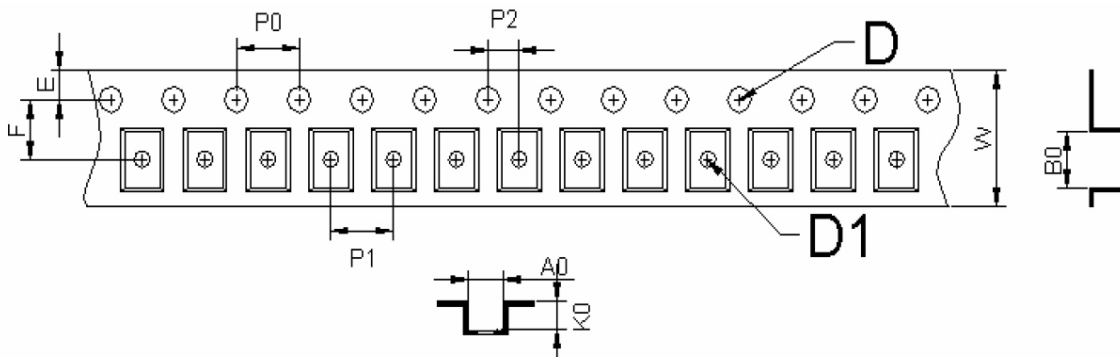

mm	A0	B0	W	F	E	P0	P1	P2	D1	D	K0	t
Dimension	2.80	3.71	8.00	3.50	1.75	4.00	4.00	2.00	1.50	1.00	1.75	0.25
Tolerance	±0.10	±0.10	+0.30/-0.10	±0.05	±0.10	±0.10	±0.10	±0.05	+0.10/-0.00	+0.25/-0.00	±0.10	±0.02