

Figure 2. SKY73120-11 Functional Block Diagram

Table 1. SKY73120-11 Signal Descriptions

Pin #	Name	Description	Pin #	Name	Description
1	GND	Ground	15	BS0	Band select 0
2	GND	Ground	16	BS1	Band select 1
3	GND	Ground	17	NC	No connection
4	GND	Ground	18	NC	No connection
5	GND	Ground	19	NC	No connection
6	GND	Ground	20	VDD	Power supply
7	GND	Ground	21	GND	Ground
8	GND	Ground	22	GND	Ground
9	GND	Ground	23	GND	Ground
10	VTUNE	Tune voltage	24	GND	Ground
11	GND	Ground	25	GND	Ground
12	GND	Ground	26	GND	Ground
13	GND	Ground	27	GND	Ground
14	GND	Ground	28	RF_OUT	RF output

Technical Description

The SKY73120-11 is a fully integrated VCO that includes varactors, a band select module, oscillator, output buffer, and RF balun. The output power from the RF balun is 0 dBm and the output impedance is designed to be 50 Ω.

The band select module can be used to change the center operation frequency of the VCO by controlling the BS1 and BS0

pin signals. This allows the total frequency range to be extended by keeping the same Kv and phase noise performance. The control logic for the BS1 and BS0 pins is shown in Table 2 and illustrated in Figure 3.

The band select pins BS0 and BS1 contain 10 kΩ pull-up resistors.

Table 2. Band Select Logic Table

BS1 (Pin 16)	BS0 (Pin 15)	Minimum Output Frequency Range (MHz) (VTUNE = 0.2 to 2.8 V)
0	0	940 to 960
0	1	928 to 940
1	0	902 to 928
1	1	890 to 902

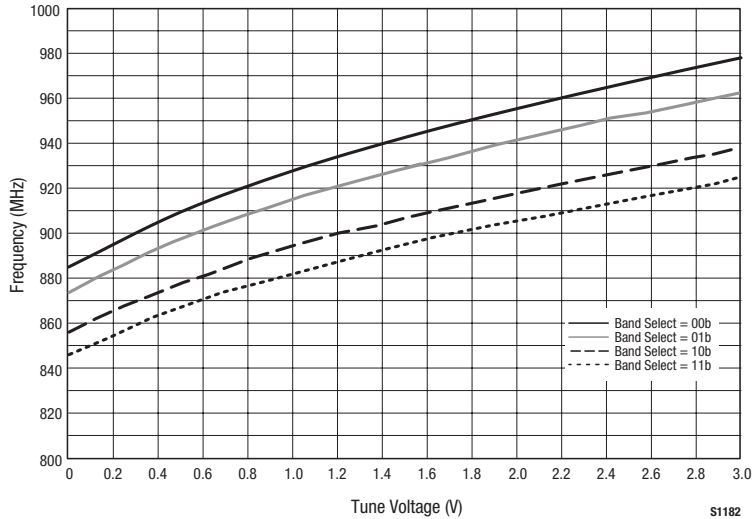

Figure 3. SKY73120-11 Operation Frequency vs Tuning Voltage and Band Select

Package and Handling Information

Since the device package is sensitive to moisture absorption, it is baked and vacuum packed before shipping. Instructions on the shipping container label regarding exposure to moisture after the container seal is broken must be followed. Otherwise, problems related to moisture absorption may occur when the part is subjected to high temperature during solder assembly.

The SKY73120-11 is rated to Moisture Sensitivity Level 3 (MSL3) at 260 °C. It can be used for lead or lead-free soldering. For additional information, refer to Skyworks Application Note, *PCB Design and SMT Assembly/Rework Guidelines for MCM-L Packages*, document number 101752.

Care must be taken when attaching this product, whether it is done manually or in a production solder reflow environment. Production quantities of this product are shipped in a standard tape and reel format. For packaging details, refer to the Skyworks Application Note, *Tape and Reel*, document number 101568.

Electrical and Mechanical Specifications

The absolute maximum ratings of the SKY73120-11 are provided in Table 3. The recommended operating conditions are specified in Table 4 and electrical specifications are provided in Table 5. Phase noise characteristics are shown in Figure 4.

The PCB layout footprint for the SKY73120-11 is provided in Figure 5. Figure 6 shows the package dimensions for the 28-pin MCM and Figure 7 provides the tape and reel dimensions.

Electrostatic Discharge (ESD) Sensitivity

The SKY73120-11 ESD threshold level is 2500 VDC using Human Body Model (HBM) testing. This level applies to RF signal lines >100 MHz, analog and RF lines <100 MHz, digital lines, power supply lines, and ground pins.

To avoid latent or visible ESD damage, always follow proper ESD handling precautions.

Table 3. SKY73120-11 Absolute Maximum Ratings (Note 1)

Parameter	Symbol	Min	Typical	Max	Units
Supply voltage	VCC			5.5	V
Storage temperature	T _{ST}	-40		+150	°C
Operating case temperature	T _C	-40		+85	°C

Note 1: Exposure to maximum rating conditions for extended periods may reduce device reliability. There is no damage to device with only one parameter set at the limit and all other parameters set at or below their nominal values.

Table 4. SKY73120-11 Recommended Operating Conditions

Parameter	Symbol	Min	Typical	Max	Units
Supply voltage	VCC	3.1	3.3	3.6	V
Tuning voltage	VTUNE	0.2		2.8	V
Load connected to RF output		50 Ω, maximum VSWR (load input) 2.0:1, all phases			
Band-select voltage level	BS _{HIGH} BS _{LOW}	2.3		0.1	V V

Table 5. SKY73120-11 Electrical Characteristics (VDD = 3.3 V, T_C = 25 °C Unless Otherwise Noted)

Parameter	Symbol	Test Conditions	Min	Typical	Max	Units
Oscillation frequency			890		960	MHz
Tuning voltage: @ 890 MHz @ 960 MHz		Band select = 11b Band select = 00b		1 2		V V
Tuning sensitivity			20	28	40	MHz/V
Output level				0		dBm
Output impedance				50		Ω
Harmonic suppression: 2 nd harmonic 3 rd harmonic				-30 -35	-20 -20	dBc dBc
Single sideband phase noise: @ 12.5 kHz offset @ 25 kHz offset @ 100 kHz offset @ 1 MHz offset				-100 -110 -124 -144	-88 -95 -108 -128	dBc/Hz dBc/Hz dBc/Hz dBc/Hz
Pushing		VCC = 3.1-3.6 V		2.3		MHz _{p-p}
Pulling		12 dB RL		80		kHz _{p-p}
Current consumption				22	30	mA

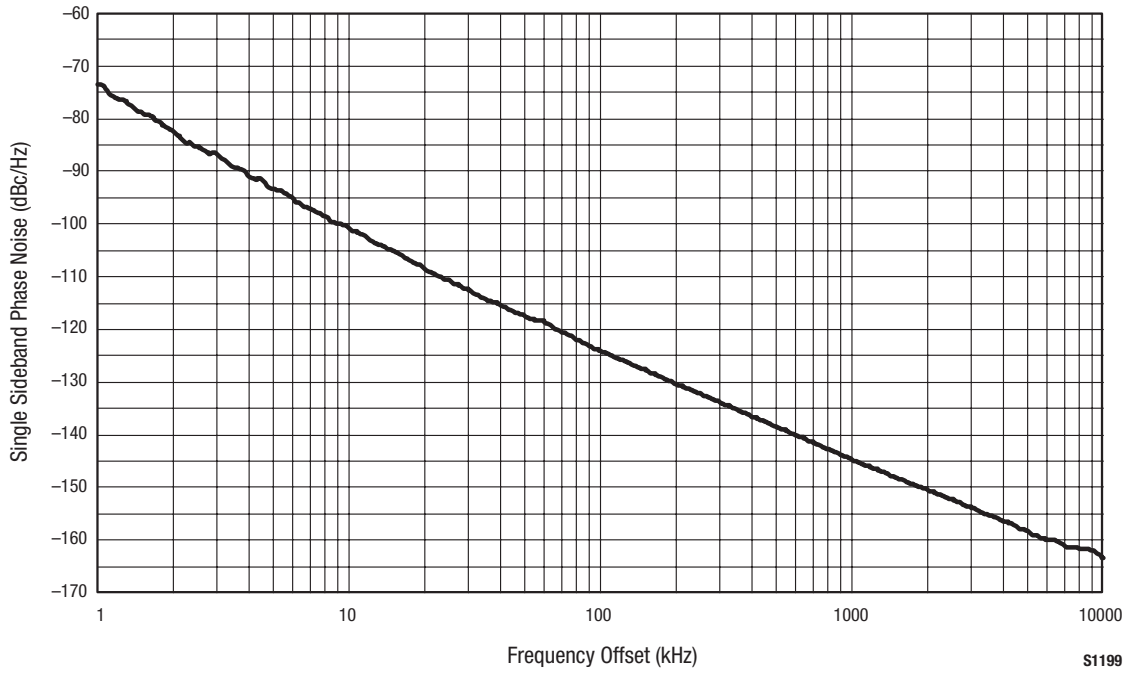
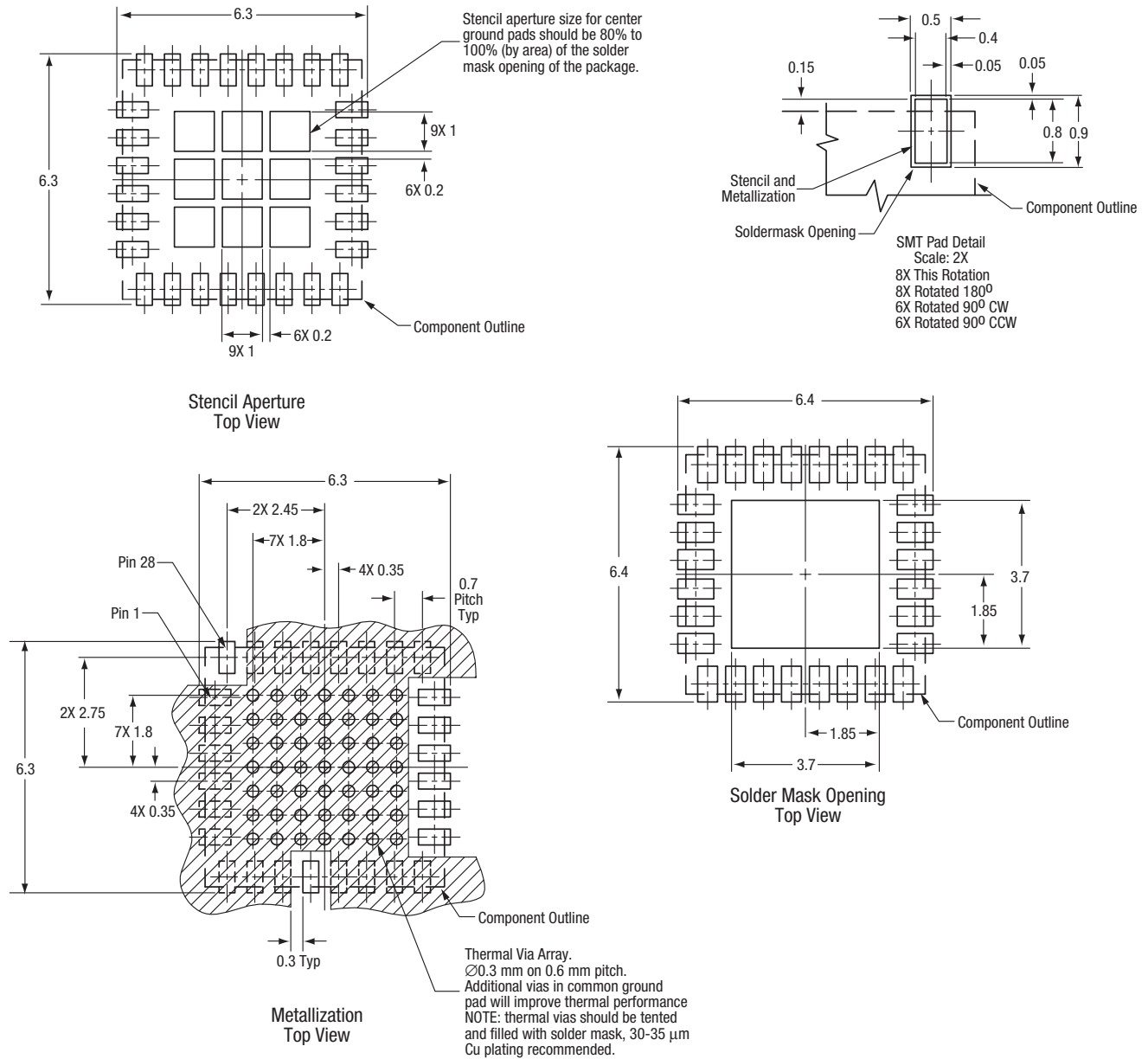

Figure 4. Single Sideband Phase Noise Measurements @ 951 MHz, VTUNE = 1.5 V, and Band Select = 00b



Note: The cross-hatched area represents the merger of the center ground pad +20 individual I/O ground pads. All I/O ground pads should have at least one via connected to internal ground planes for optimum electrical performance.

All measurements are in millimeters

S1197

Figure 5. PCB Layout Footprint for the SKY73120-11 6 x 6 MCM

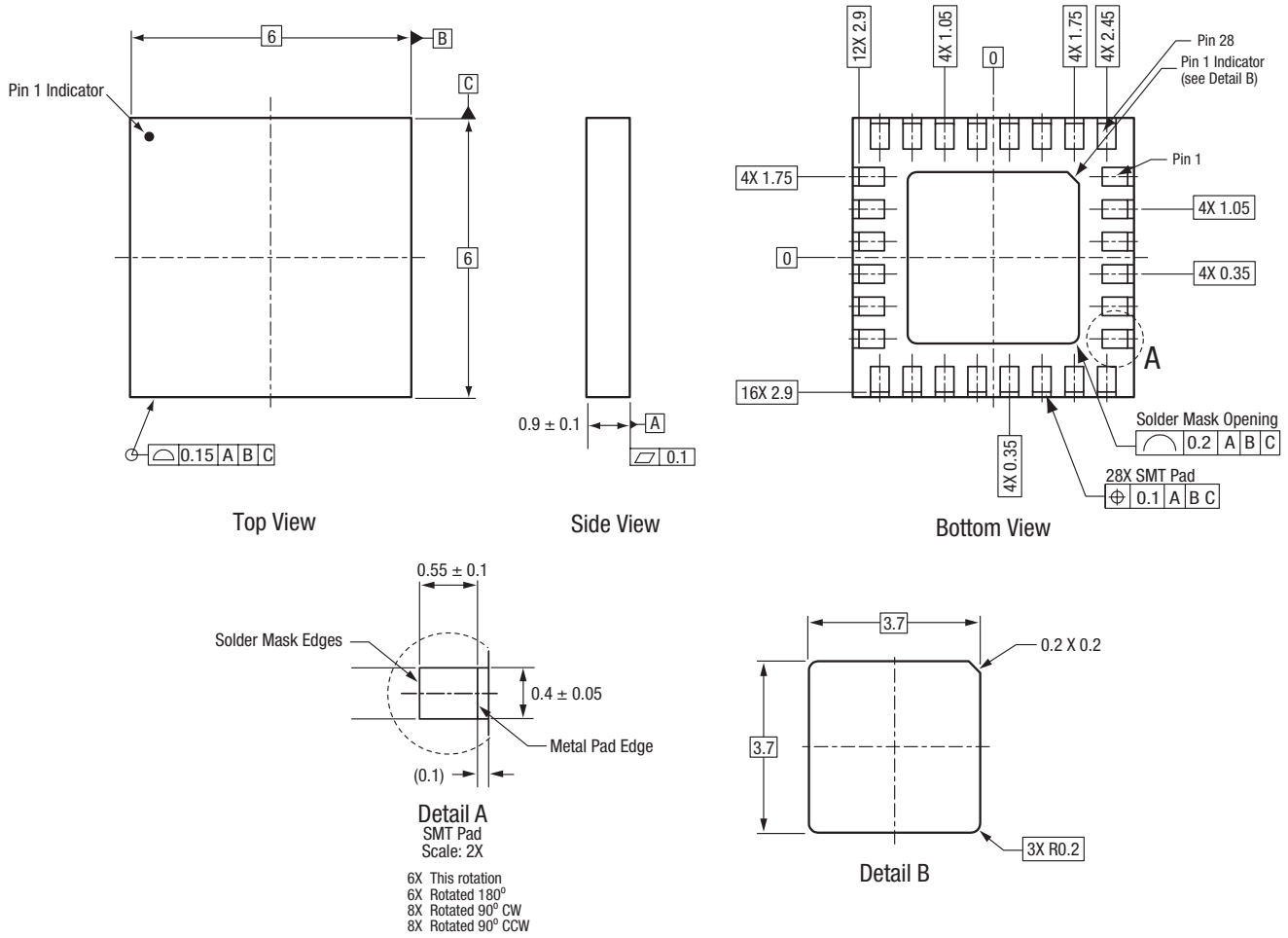

All measurements are in millimeters

Dimensioning and tolerancing according to ASME Y14.5M-1994

S1172

Figure 6. SKY73120-11 28-Pin MCM Package Dimensions

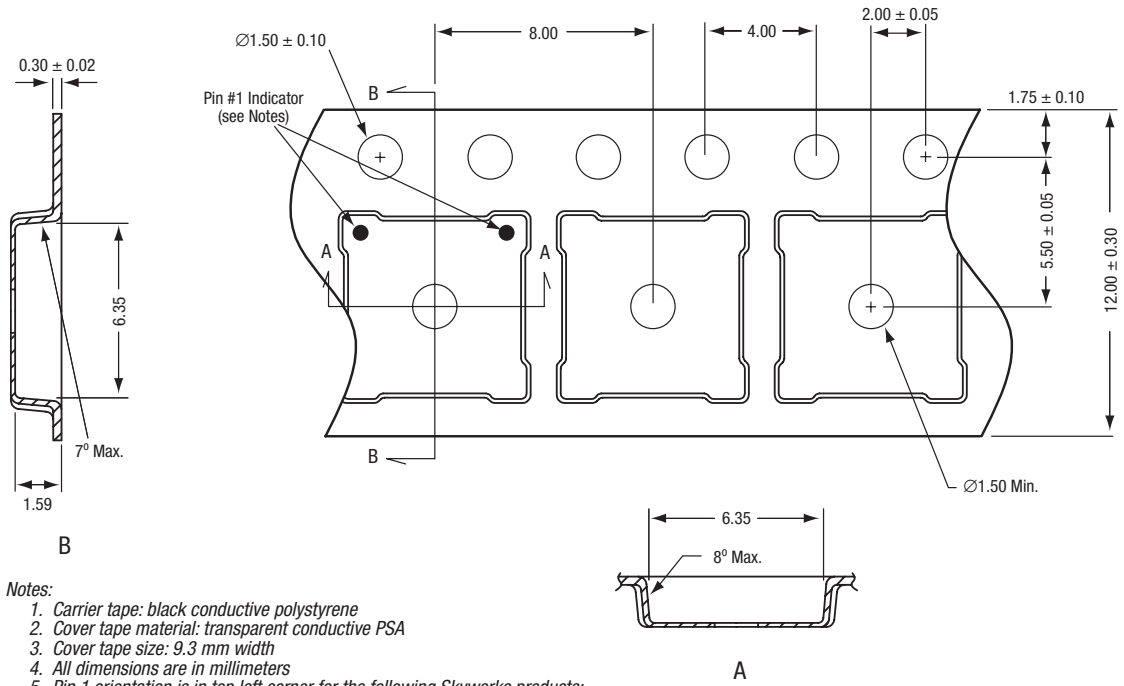

S1183

Figure 7. SKY73120-11 Tape and Reel Dimensions

Ordering Information

Model Name	Manufacturing Part Number	Evaluation Kit Part Number
SKY73120-11 890-960 MHz VCO	SKY73120-11 (Pb-free package)	TW17-D640

Copyright © 2007, 2008 Skyworks Solutions, Inc. All Rights Reserved.

Information in this document is provided in connection with Skyworks Solutions, Inc. (“Skyworks”) products or services. These materials, including the information contained herein, are provided by Skyworks as a service to its customers and may be used for informational purposes only by the customer. Skyworks assumes no responsibility for errors or omissions in these materials or the information contained herein. Skyworks may change its documentation, products, services, specifications or product descriptions at any time, without notice. Skyworks makes no commitment to update the materials or information and shall have no responsibility whatsoever for conflicts, incompatibilities, or other difficulties arising from any future changes.

No license, whether express, implied, by estoppel or otherwise, is granted to any intellectual property rights by this document. Skyworks assumes no liability for any materials, products or information provided hereunder, including the sale, distribution, reproduction or use of Skyworks products, information or materials, except as may be provided in Skyworks Terms and Conditions of Sale.

THE MATERIALS, PRODUCTS AND INFORMATION ARE PROVIDED “AS IS” WITHOUT WARRANTY OF ANY KIND, WHETHER EXPRESS, IMPLIED, STATUTORY, OR OTHERWISE, INCLUDING FITNESS FOR A PARTICULAR PURPOSE OR USE, MERCHANTABILITY, PERFORMANCE, QUALITY OR NON-INFRINGEMENT OF ANY INTELLECTUAL PROPERTY RIGHT; ALL SUCH WARRANTIES ARE HEREBY EXPRESSLY DISCLAIMED. SKYWORKS DOES NOT WARRANT THE ACCURACY OR COMPLETENESS OF THE INFORMATION, TEXT, GRAPHICS OR OTHER ITEMS CONTAINED WITHIN THESE MATERIALS. SKYWORKS SHALL NOT BE LIABLE FOR ANY DAMAGES, INCLUDING BUT NOT LIMITED TO ANY SPECIAL, INDIRECT, INCIDENTAL, STATUTORY, OR CONSEQUENTIAL DAMAGES, INCLUDING WITHOUT LIMITATION, LOST REVENUES OR LOST PROFITS THAT MAY RESULT FROM THE USE OF THE MATERIALS OR INFORMATION, WHETHER OR NOT THE RECIPIENT OF MATERIALS HAS BEEN ADVISED OF THE POSSIBILITY OF SUCH DAMAGE.

Skyworks products are not intended for use in medical, lifesaving or life-sustaining applications, or other equipment in which the failure of the Skyworks products could lead to personal injury, death, physical or environmental damage. Skyworks customers using or selling Skyworks products for use in such applications do so at their own risk and agree to fully indemnify Skyworks for any damages resulting from such improper use or sale.

Customers are responsible for their products and applications using Skyworks products, which may deviate from published specifications as a result of design defects, errors, or operation of products outside of published parameters or design specifications. Customers should include design and operating safeguards to minimize these and other risks. Skyworks assumes no liability for applications assistance, customer product design, or damage to any equipment resulting from the use of Skyworks products outside of stated published specifications or parameters.

Skyworks, the Skyworks symbol, and “Breakthrough Simplicity” are trademarks or registered trademarks of Skyworks Solutions, Inc., in the United States and other countries. Third-party brands and names are for identification purposes only, and are the property of their respective owners. Additional information, including relevant terms and conditions, posted at www.skyworksinc.com, are incorporated by reference.