



AK2306/2306LV

Dual PCM CODEC for ISDN/VoIP TERMINAL ADAPTER

GENERAL DESCRIPTION

AK2306 is a dual PCM CODEC-Filter most suitable for ISDN Terminal Adapter.

It includes Selectable A-law/u-law function, Internal Gain Adjustment from +6dB to -18dB by 1dB step control, Selectable 16Hz/20Hz Ring Tone Generator for SLIC. All of these functions are controlled by the internal register accessed through the serial interface.

PCM interface of AK2306 accepts Long Frame, Short Frame clock formats and GCI format. 64 x N kHz(128k-4096kHz) clock input is available for PCM interface.

AK2306 and AK2306LV are pin-compatible, but different products which power supply voltage are 5.0V and 3.3V, respectively.

FEATURE

- Dual PCM CODEC and Filtering systems for ISDN Terminal Adapter
- Selectable Ring Tone Generator for SLIC
 - 16Hz or 20Hz tone is available.
- Independent functions on each channel controlled by the internal register
 - Power Down Mode
 - Mute
 - Gain Adjustment: +6 to -18dB (1dB step)
- Selectable PCM Data Interface Timing: Long Frame / Short Frame/GCI
- Variable PCM Data Rate: 64k x N [Hz] (128k - 4.096MHz)
- OP Amp for External Gain Adjustment
- A-law/u-law Register Selectable
- Serial Interface to access the internal register
- Power on Reset
- Single Power Supply Voltage
 - +5.0V \pm 5% (AK2306)
 - +3.3V \pm 0.3V (AK2306LV)
- Low Power Consumption

PACKAGE

- 24pinSSOP
- 8.2 x 7.9 mm (0.65mm pin pitch)

CONTENTS

ITEMS	PAGE
- BLOCK DIAGRAM.....	3
- PIN ASSIGNMENT.....	4
- PIN CONDITION.....	5
- PIN FUNCTION.....	6
- CIRCUIT DESCRIPTION.....	8
- FUNCTIONAL DESCRIPTION.....	9
- PCM INTERFACE.....	9
LONGFRAME/SHORTFRAME/GCI	
- MUTE.....	12
- GAIN ADJUSTMENT.....	13
- RING TONE GENERATOR	14
- RESET	15
- POWER DOWN.....	16
- SERIAL INTERFACE.....	18
- REGISTER.....	22
- ABSOLUTE MAXIMUM RATINGS.....	25
- RECOMMENDED OPERATING CONDITIONS.....	25
- ELECTRICAL CHARACTERISTICS.....	25
- APPLICATION CIRCUIT EXAMPLE.....	34
- PACKAGE INFORMATION.....	36

BLOCK DIAGRAM

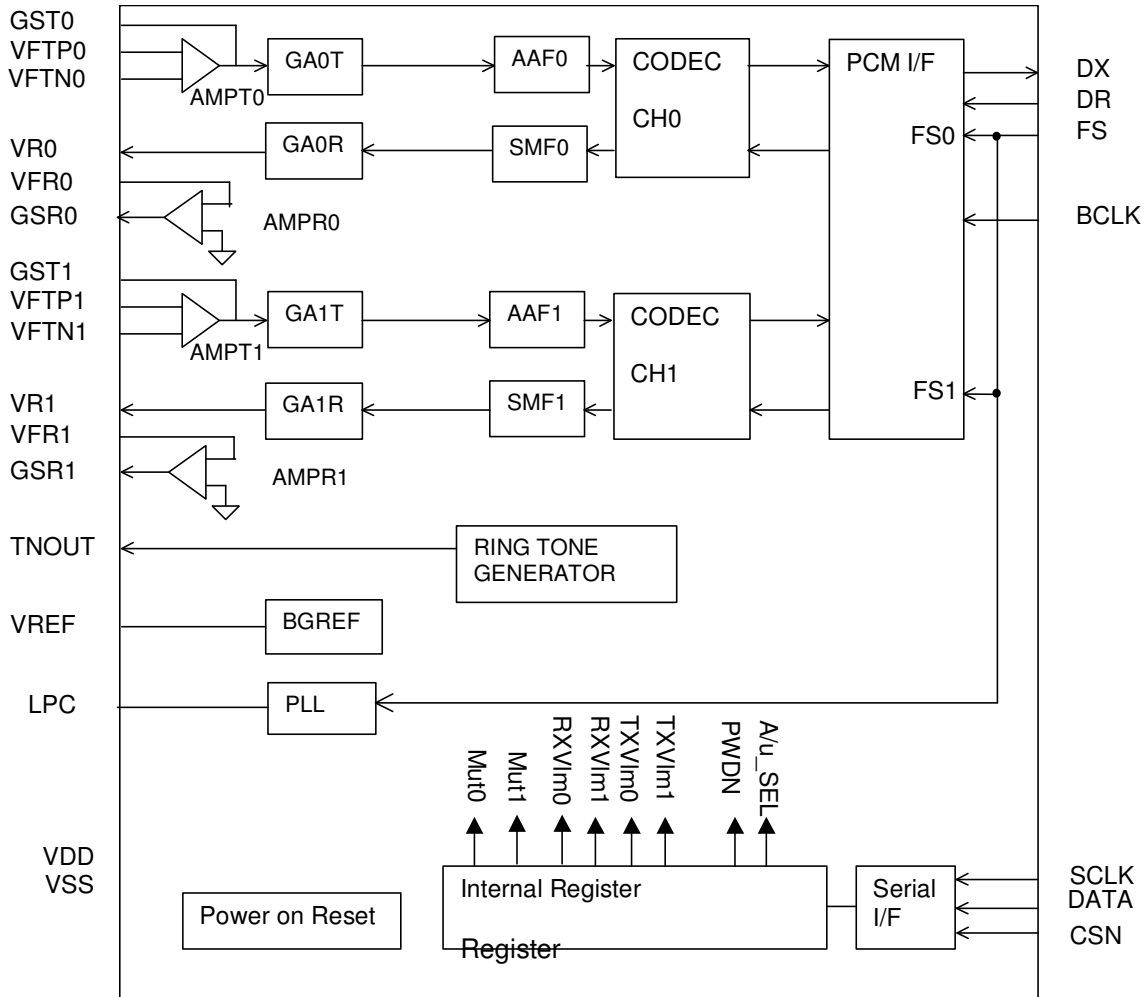

PIN ASSIGNMENT

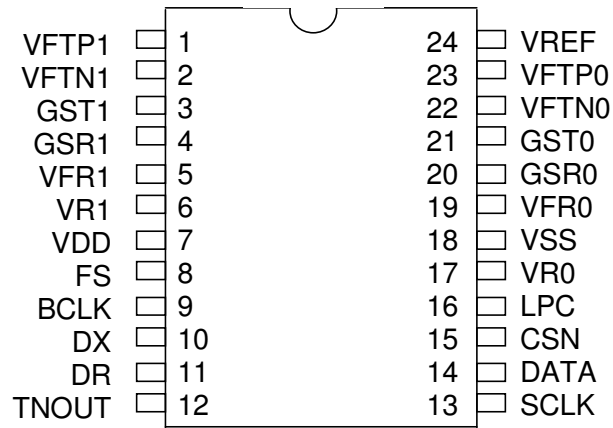

PIN CONDITION

Pin#	Name	I/O	Pin type	AC load (MAX.)	DC load (MIN.)	Output status (Power down mode)	Output status (Reset)	Remarks
	VFTP1		Analog					
	VFTN1		Analog					
	GST1		Analog	50pF	10kΩ(*1)	Hi-Z	Hi-Z	
	GSR1	O	Analog	50pF	10kΩ (*1)	Hi-Z	Hi-Z	
	VFR1	I	Analog					
	VR1	O	Analog	50pF	10kΩ	Hi-Z	Hi-Z	
	VDD	-						
	FS	I	TTL/CMOS(*3)					
	BCLK	I	TTL/CMOS(*3)					
	DX	O	CMOS	15pF		Hi-Z	Hi-Z	
	DR	I	TTL/CMOS(*3)					
	TNOUT	O	CMOS	15pF		L	L	
	SCLK	I	TTL/CMOS(*3)					
	DATA	I/O	TTL/CMOS(*3)	15pF		Input	Input	
	CSN	I	TTL/CMOS(*3)					
	LPC	O	Analog					0.22uF (*2)
	VSS	-						
	VR0	O	Analog	50pF	10kΩ	Hi-Z	Hi-Z	
	VFR0	I	Analog					
	GSR0	O	Analog	50pF	10kΩ (*1)	Hi-Z	Hi-Z	
	GST0	I	Analog	50pF	10kΩ (*1)	Hi-Z	Hi-Z	
	VFTN0	O	Analog					
	VFTP0	O	Analog					
	VREF	O	Analog					1.0 uF (*2)

*1) DC load(MIN.) includes a feedback resistance of input/output op-amp.

*2)External capacitance should be connected to VSS.

*3)TTL level is applied only for the input level of AK2306. Output level for both AK2306 and AK2306LV, and the input level of AK2306LV are CMOS level.

PIN FUNCTION

Pin#	Name	I/O	Function
1	VFTP1	I	Positive analog input of the transmit OPamp(AMPT1) for channel 1. Transmit gain is defined by the ratio of R2/R1. R1 is the external input resistor connected to this pin. R2 is the external feedback resistor connected between this pin and GST1.
2	VFTN1	I	Negative analog input of the transmit OPamp(AMPT1) for channel 1.
3	GST1	O	Output of the transmit OPamp(AMPT1) for channel 1. The external feedback resistor is connected between this pin and VFTP1.
4	GSR1	O	Output of the receive OPamp(AMPR1) for channel 1.
5	VFR1	I	Negative analog input of the receive OPamp(AMTR1) for channel 1. Receive gain is defined by the ratio of R4/R3. R3 is the external input resistor connected to this pin. R4 is the external feedback resistor connected between this pin and VR1.
6	VR1	O	Analog Output equivalent to the received PCM data for channel 1. Output gain is adjusted by the GA1R.
22	VFTN0	I	Negative analog input of the transmit OPamp(AMPT0) for channel 0. Transmit gain is defined by the ratio of R2/R1. R1 is the external input resistor connected to this pin. R2 is the external feedback resistor connected between this pin and GST0.
23	VFTP0	I	Positive analog input of the transmit OPamp(AMPT0) for channel 0.
21	GST0	O	Output of the transmit OPamp(AMPT0) for channel 0. The external feedback resistor is connected between this pin and VFTP0.
17	VR0	O	Analog Output equivalent to the received PCM data for channel 0. Output gain is adjusted by the GA0R
19	VFR0	I	Negative analog input of the receive OPamp(AMTR0) for channel 0. Receive gain is defined by the ratio of R4/R3. R3 is the external input resistor connected to this pin. R4 is the external feedback resistor connected between this pin and VR0.
20	GSR0	O	Output of the receive OPamp(AMPR0) for channel 0.
10	DX	O	Serial output of PCM data. The channel 1 data is output following the channel 0 data. The PCM data rate is synchronized with BCLK. This output remains in the high impedance state except for the period of transmitting PCM data.
11	DR	I	Serial input of PCM data. The channel 1 data is received following the channel 0 data. The PCM data rate is synchronized with BCLK.
8	FS	I	Frame sync input. This clock is input for the internal PLL which generates the internal system clocks. FS must be 8kHz clock which is synchronized with BCLK.
9	BCLK	I	Bit clock of PCM data interface. This clock defines the input/output timing of DX and DR. The frequency of BCLK should be 64 x N kHz(128k – 4096kHz).

Pin#	Name	I/O	Function
12	TNOUT	O	Ring Tone output pin. 16Hz or 20Hz tone is selected by the internal register.
14	DATA	I/O	Data input of serial interface.
13	SCLK	I	Clock input of serial interface.
15	CSN	I	Read and write enable of serial interface.
16	LPC	O	Pin for PLL loop filter. External capacitance(Min 0.22uF) should be connected between this pin and VSS.
24	VREF	O	Analog ground output. External capacitance(1.0 uF) should be connected between this pin and VSS.
7	VDD	-	Positive supply voltage. +5V(AK2306) or +3.3V(AL2306LV) supply.
18	VSS	-	Ground.

CIRCUIT DESCRIPTION

Block	Function
AMPT0,1	Op-amp for input gain adjustment. This op-amp has differential inputs. Adjusting the gain with external resistors. The resistor larger than 10kΩ is recommended for the feedback resistor. <NOTE> AMPT0(1) becomes automatically power down, when CODEC ch0(1) is power down.
AMPR0,1	Op-amp for output gain adjustment. This op-amp is used as an inverting amplifier. Adjusting the gain with external resistors. The resistor larger than 10kΩ is recommended for the feedback resistor.
AAF	Integrated anti-aliasing filter which prevents signals around the sampling rate from folding back into the voice band. AAF is a 2nd order RC low-pass filter.
A/D	Converts analog signal to 8bit PCM data according to the companding schemes of ITU recommendation G.711; A-law or u-law. The band limiting filter is also integrated. The selection of companding schemes is set by ALAWN register as follows: "H": u-Law "L": A-Law
D/A	Expands 8bit PCM data according to A-law or u-law. The selection of companding schemes is set by ALAWN register as follows: "H": u-Law "L": A-Law
SMF	Extracts the inband signal from D/A output. It also corrects the sinx/x effect of D/A output.
BGREF	Provides the stable analog ground voltage using an on-chip band-gap reference circuit which is temperature compensated. The output voltage is 2.4V for +5V operation(AK2306) or 1.5V for +3.3V operation(AK2306LV).
RING TONE GENERATOR	Generates two kinds of tone; 16Hz or 20Hz. Tone selection and Tone ON/OFF is controlled by the registers.
GA0T/R GA1T/R GATN	Gain selects of analog I/O signals. It is possible to select gain from +6dB to -18dB (1dB/step). Gain is defined by the internal register.
SERIAL I/F	Interface to the internal register by using SCLK, DATA, and CSN pins.
PLL	PLL generates system clock of AK2306. Reference clock is FS (8KHz). More than 0.22uF of an external capacitance should be connected between LPC and VSS.
PCM I/F	PCM data rate is available for 64xN(N = 2 to 64)kHz which synchronizes with BCLK. Two kinds of data format (Long Frame, Short Frame) are available. Each data format is automatically detected. PCM data stream, which includes ch0 and ch1 data, is output through DX pin and input through DR pin. Ch1 PCM data stream always follows ch0 PCM data stream.

FUNCTIONAL DESCRIPTION

PCM Data Interface

AK2306 supports the following 3 PCM data formats

- Long Frame Sync(LF)
- Short Frame Sync(SF)
- GCI

PCM data of both channels are multiplexed and interfaced through the common pins(DR,DX).The first 8bit is defined as B1 channel and the seconds 8bit is defined as B2 channel in the PCM data stream.
The order of PCM data is MSB first in each channel.

Selection of the interface mode

The GCI and ordinary PCM interface(LF,SF) are selectable through the CPU register as following table.
LF and SF is automatically selected by AK2306 by means of detecting the length of 8KHz frame signal.

Register for PCM Interface mode select (Address:101 Bit:0)

PCMIF	PCM Interface	Comments
0	LF or SF	LF/SF are selected automatically
1	GCI	

* Default on power-on reset =LF/SF mode(PCMIF=0).

LONG FRAME(LF) / SHORT FRAME (SF)**Automatic LF/SF selection**

AK2306 monitors the duration of the "H" level of FS and automatically selects LF or SF interface format.

period of FS="H"	Interface format
more than 2 clocks of BCK	LF
1 clock of BCK	SF

Timing of the interface

8 bits PCM data is accommodated in 1 frame(125us) defined by 8kHz frame sync signal.

Although there are 64 time slots at maximum in 8kHz frame(when BCK=4.096MHz), PCM data for AK2306 occupy first and second time slot for channel 0 and channel 1, respectively as is indicated in figures of next page.

- Frame Sync signal (FS)

8kHz reference signal. This signal indicated the timing and the frame position of 8kHz PCM interface. All the internal clock of the LSI is generated based on this FS signal.

- Bit Clock (BCLK)

BCLK defines the PCM data rate. BCLK can be varied from 128kHz to 4.096MHz by 64kHz step.

- Position of the Ch0,Ch1 PCM data in the DX/DR data flow

B1 and B2 channel of the PCM data channel are assigned to Analog Ch0 and Ch1 as is defined by SEL2B register.

CH0,1selection (Address:100 Bit:5)

SEL2B	CH0	CH1	Remarks
0	B1	B2	Default on Reset
1	B2	B1	

<2ch Multiplexed>

LongFrame

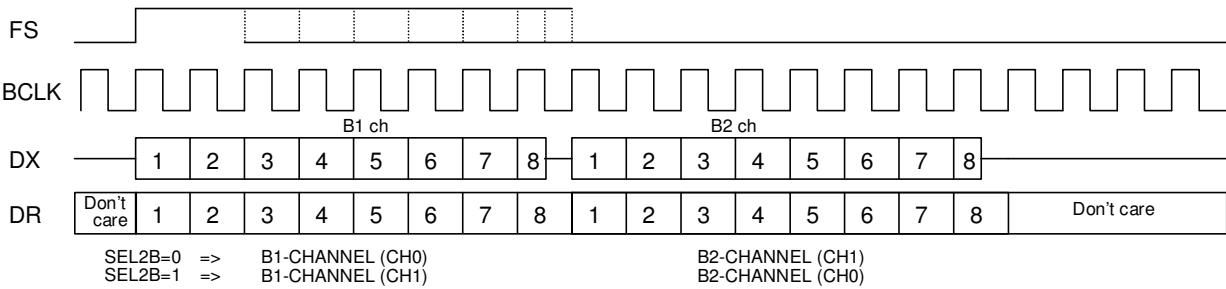

ShortFrame

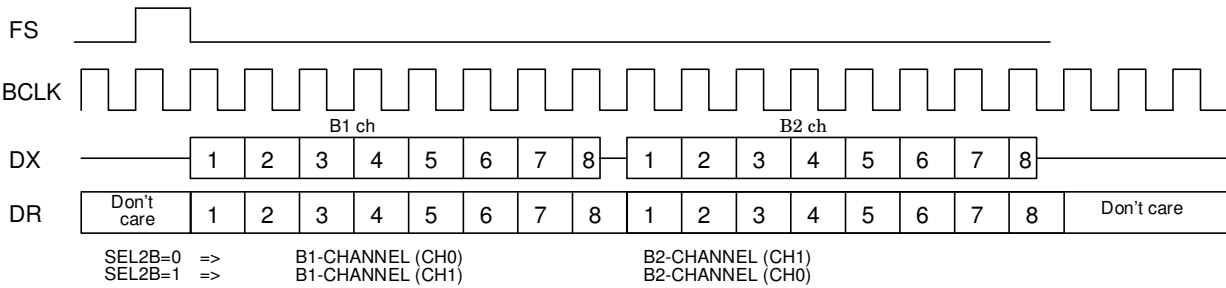

<Non Multiplex>

Not supported

! Important Notice

Please don't stop feeding FS and BCLK except Full power down mode.

Internal PLL does free running when either FS or BCLK is not provided. In this case, the frequency of Ring Tone output is not guaranteed.

GCI (General Circuit Interface)

GCI format is used for ISDN application. The data format and clocking is showed as Fig X.

timing of the interface

8 bits PCM data is accommodated in 1 frame(125us) defined by 8kHz frame sync signal. Although there are 32 time slots at maximum in 8kHz frame(when BCK=4.096MHz), PCM data on GCI occupy first and second time slot for channel 0 and channel 1, respectively.

Frame Sync signal (FS)

8kHz reference signal. This signal indicated the timing and the frame position of 8kHz GCI. All the internal clock of the LSI is generated based on this FS signal. High level duration of the FS is 1 clock period of BCLK.

Bit Clock (BCLK)

BCLK defines the GCI data rate. The bit rate of GCI data is half of BCLK. BCLK can be varied from 512kHz to 4.096MHz by 128kHz step.

Position of the Ch0,Ch1 GCI data in the DX/DR data flow

B1 and B2 channel of the GCI data channel are assigned to Analog Ch0 and Ch1 as is defined by SEL2B register as same way as PCM interface.

CH0,1selection(Address:100 Bit:5)

SEL2B	CH0	CH1	Remarks
0	B1	B2	Default on Reset
1	B2	B1	

<2ch Multiplex>

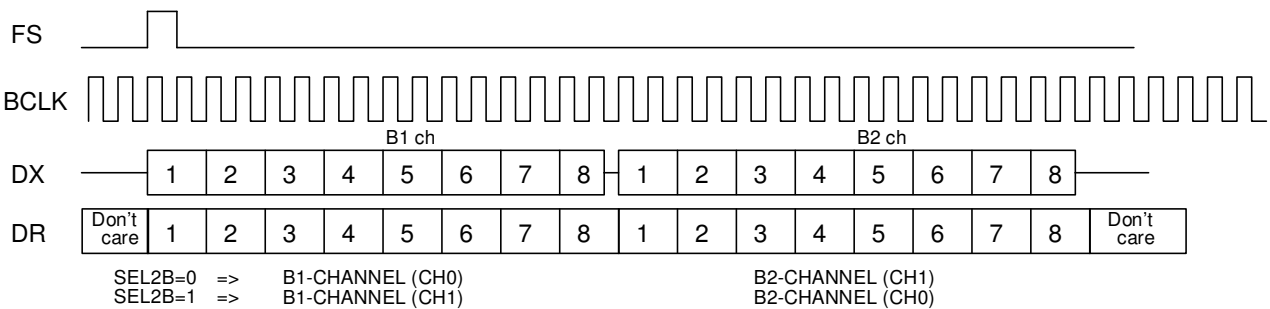

<Non Multiplex>

Not supported

! Important Notice

Please don't stop feeding FS and BCLK except Full power down mode.

Internal PLL does free running when either FS or BCLK is not provided. In this case, the frequency of Ring Tone output is not guaranteed.

MUTE

The output on each channel can be muted independently through the CPU register as shown in the table.

Mute register(Address:100 Bit:5,4)

MTCH0,1	Operation	DX pin	VRX pin
0	Normal	PCM data output	CODEC analog output
1	Mute	High-Impedance(*1)	AGND*

(*1)

MTCH0 and MTCH1 are the mute control bit for CH0 and CH1, respectively. B1 and B2 channel muted by MTCH0/1 is defined by SEL2B bit shown in the PCM Interface section.

<EXAMPLE>

LF Mode CH0 mute (MTCH=1, MTCH1=0, SEL2B=0)

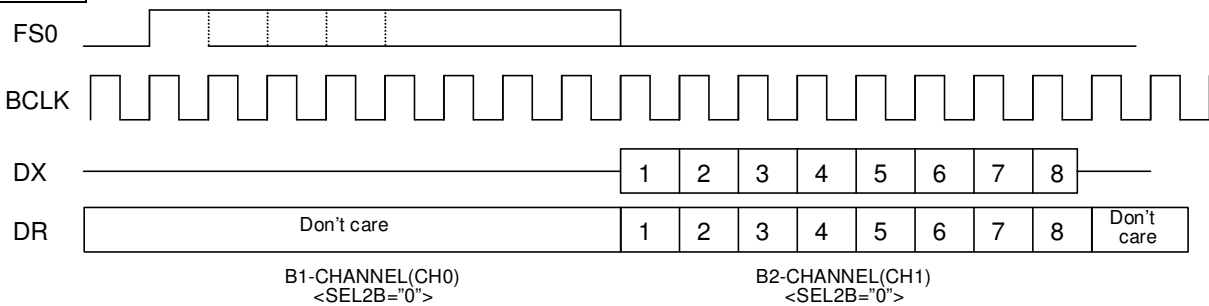

VRX0 : CODEC CH0 analog output is always at AGND level.

VRX1 : CODEC CH1 analog output is the signal converted from the PCM data of CH1 input through DR pin.

GCI mode CH0 mute (MTCH0=1, MTCH1=0, SEL2B=0)

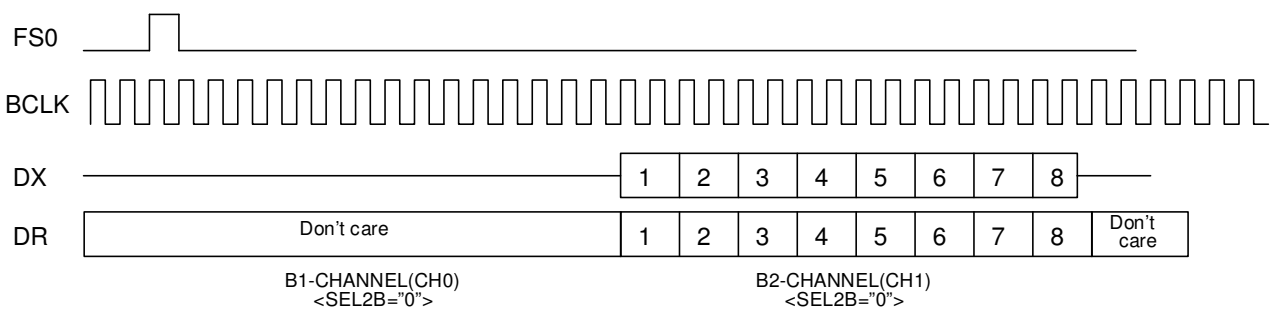

VRX0 : CODEC CH0 analog output is always at AGND level.

VRX1 : CODEC CH1 analog output is the signal converted from the PCM data of CH1 input through DR pin.

GAIN ADJUSTMENT

Analog input/output gain can be adjusted at the range from +6dB to -18dB by 1.0dB step through CPU register.

VR Register(Address:011 -000 Bit:4 -0)

GanT4 GanR4	GanT3 GanR3	GAnT2 GAnR2	GAnT1 GAnR1	GAnT0 GAnR0	Gain [dB]	Remarks
0	0	0	0	0	+6	
0	0	0	0	1	+5	
0	0	0	1	0	+4	
0	0	0	1	1	+3	
0	0	1	0	0	+2	
0	0	1	0	1	+1	
0	0	1	1	0	0	Default
0	0	1	1	1	-1	
0	1	0	0	0	-2	
0	1	0	0	1	-3	
0	1	0	1	0	-4	
0	1	0	1	1	-5	
0	1	1	0	0	-6	
0	1	1	0	1	-7	
0	1	1	1	0	-8	
0	1	1	1	1	-9	
1	0	0	0	0	-10	
1	0	0	0	1	-11	
1	0	0	1	0	-12	
1	0	0	1	1	-13	
1	0	1	0	0	-14	
1	0	1	0	1	-15	
1	0	1	1	0	-16	
1	0	1	1	1	-17	
1	1	---	---	---	-18	

RING TONE GENERATOR

Ring tone generator generates two kinds of ring tone, 16Hz and 20Hz. The frequency of the tone can be selected by CPU register.

Tone frequency selection

Tone Selection register (Address: 101, Bit: 3)

TNFQ	Tone Frequency	Remarks
0	16Hz	Default
1	20Hz	

Tone output enable

Tone output can be enabled/disabled through CPU register.

RING TONEGEN Enable (Address: 100, Bit: 2)

PDTN	RING TONE GENERATOR	Remarks
1	Power Down*	Default
0	Tone output enabled	

* When Power down is selected, TNOOUT pin output is fixed to "L" level.

RESET

Power on Reset

AK2306 automatically generates the internal reset pulse which resets all the circuit that is necessary to start the initialization after the power on reset. The CPU registers are set to the default value.

After the internal reset pulse is generated, CODEC Ch0/Ch1 starts the initialization procedure by being fed FS signal, and it takes 180ms(typ.), 350ms(max) to complete the initialization after the detection of power on.

Power up slope to enable the Power-on Reset

When power-up slope is no longer than 50ms(=5tau:tau is time constant), Power On Reset works normally.

When the time is longer than 50ms, Power On Reset is not activated and no internal registers are initialized. In this case all registers must be written through CPU interface.

NOTE) For stable operation after power up, we recommend to write all register value through CPU interface after power up.

Recommended start up procedure

The following start up procedure is recommended when AK2306/LV is going to power up.

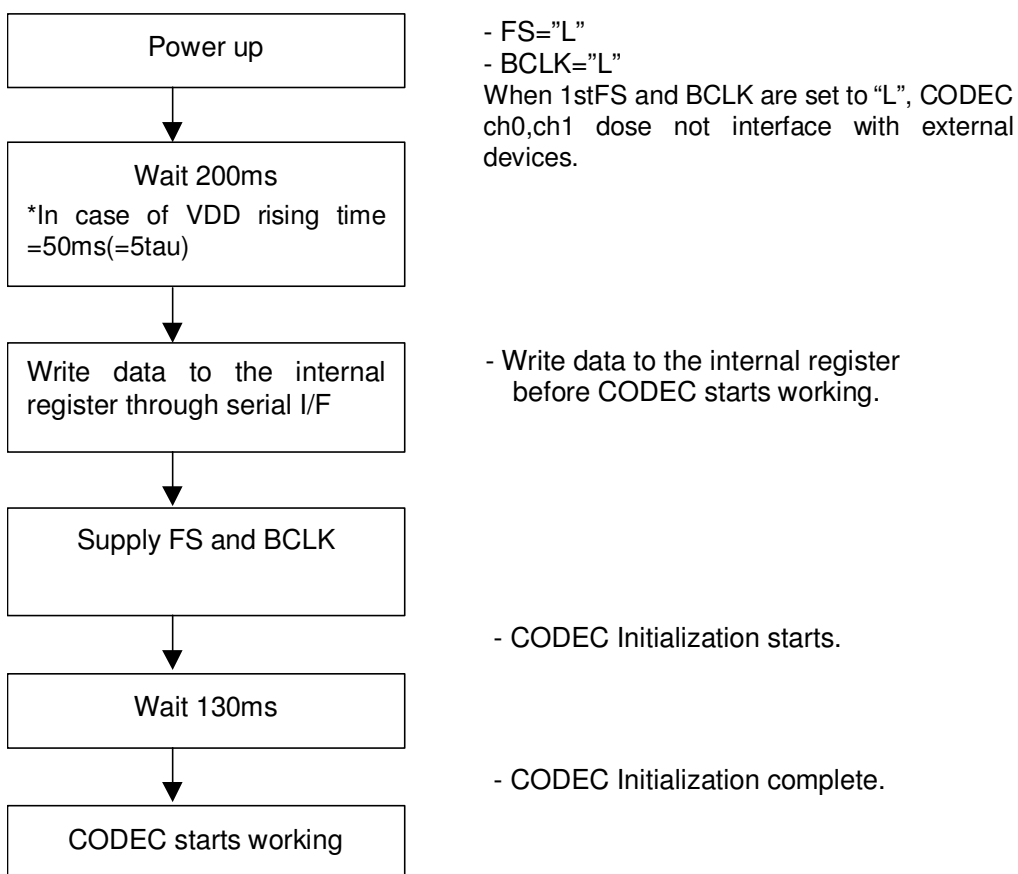

POWER DOWN

Power consumption is reduced in the power down mode.

In the power down mode, the current fed to analog circuits and the clock for digital circuits, are stopped, and the relating circuits hold its status.

There are two power down modes.

- Power down for all circuits
- Power down by block

* In the power down mode, the output pins of corresponding blocks turn to Hi-Z except TNOOUT pin.(See page 5)

POWER DOWN MODE SETTING

2 power down modes

Mode	Circuits	Registers	Operation for "0"/"1"	Note
All circuit	All	PD	"0" : Normal "1" : Power down	- CPU Registers are not reset. - Serial I/F is available. - No need to supply FS, BCLK.
Block	CODEC CH0	PDCH0	"0" : Normal "1" : Power down	- Keep supplying FS, even when CODEC CH0,1 are in power down mode (see page10,11). - When CODEC CHn(n=0,1) is in power down mode, the functions below are active: (1) AMPTn(n=0,1) Input/Output (2) TNOOUT Output Please refer next page table in detail.
	CODEC CH1	PDCH1		
	RING TONEGEN	PDTN		

CANCELLATION OF POWER DOWN : CODEC

When power down mode for CODEC CH0/CH1 is cleared, the CODEC circuitry starts to be initialized. It takes 130mS(typ.).

When full circuit power down mode for CODEC is cleared, AK2306/LV starts the same wake up sequence as one at power on. It takes 250ms(Typ)

Wake up time for Tone generator is 125us(Typ).

POWER DOWN BLOCK		ALL BLOCK	CODEC CH0	CODEC CH1	CODEC CH0&1	RING TONEGEN
REGISTER		PD	PDCH0	PDCH1	PDCH0 PDCH1	PDTN
Channel 0	AMPT0	OFF				
	GA0T	OFF	OFF		OFF	
	AAF0	OFF	OFF		OFF	
	CODEC CH0	OFF	OFF		OFF	
	SMF0	OFF	OFF		OFF	
	GA0R	OFF				
	AMPR0	OFF				
Channel 1	AMPT1	OFF				
	GA1T	OFF		OFF	OFF	
	AAF1	OFF		OFF	OFF	
	CODEC CH1	OFF		OFF	OFF	
	SMF1	OFF		OFF	OFF	
	GA1R	OFF				
	AMPR1	OFF				
PCM I/F		OFF			OFF	
RING TONEGEN		OFF				OFF
PLL		OFF				
BGREF		OFF				
SERIAL I/F						

SERIAL INTERFACE

The internal registers can be read/written with SCLK, DATA, and CSN pins.

1word consists of 16bits. The first 4bits are the instruction code which specifies read/write.
The following 3bits specify the address. The rest of 8bits are for setting registers.

B15	B14	B13	B12	B11	B10	B9	B8	B7	B6	B5	B4	B3	B2	B1	B0
I3	I2	I1	I0	A2	A1	A0	*	D7	D6	D5	D4	D3	D2	D1	D0
Instruction code (4bit)				Address (3bit)			*	Data for internal registers (8bit)							

*)Dummy bit for adjusting the I/O timing when reading register.

INSTRUCTION CODEC

I3	I2	I1	I0	Read/Write
1	1	1	0	Read
1	1	1	1	Write
Other codes				No action

SCLK and WRITE/READ

- (1) Input data are loaded into the internal shift register at the rising edge of SCLK.
- (2) The rising edge of SCLK is counted after the falling edge of CSN.
- (3) When CSN is "L" and more than 16 SCLK pulses:
 - [WRITE] Data are loaded into the internal register at the rising edge of the SCLK 16th pulse.
 - [READ] DATA pin is switched to an input pin at the falling edge of the SCLK 16th pulse.

CSN and WRITE / READ CANCELLATION

- (1) WRITE is cancelled when CSN goes up before the rising edge of the SCLK 16th pulse.
- (2) READ is cancelled when CSN goes up before the falling edge of the SCLK 16th pulse.

SERIAL WRITE / READ (SERIAL ACCESS)

- (1) CSN must go up to "H" before the next access in successive access.
- (2) When the next access is going to be done , if CSN remains to be "L", successive access can not be done.

WRITE

Continuous SCLK

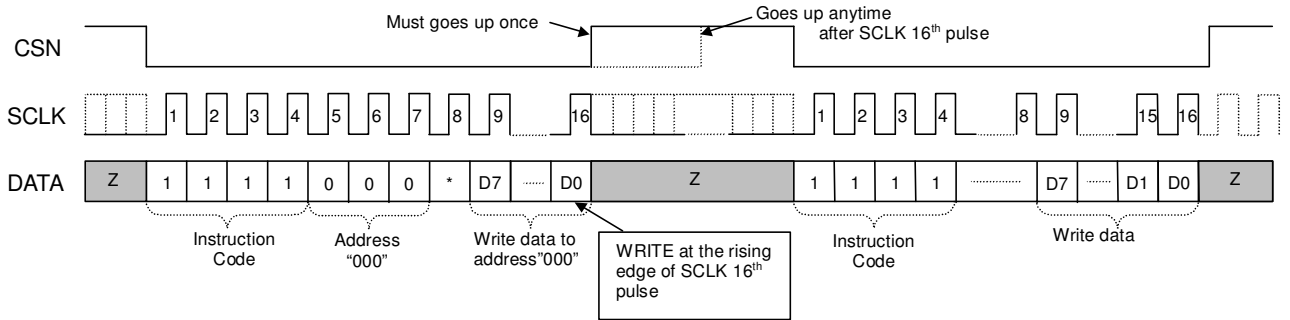

Burst SCLK

SCLK can be stop at "H" level or "L" level at anytime during the write cycle. Afer resuming the SCLK, write cycle is retrieved normally.

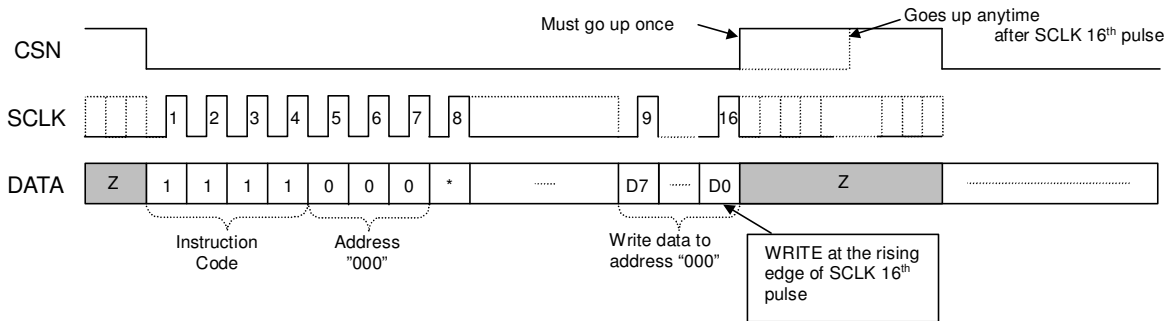

CANCELLATION

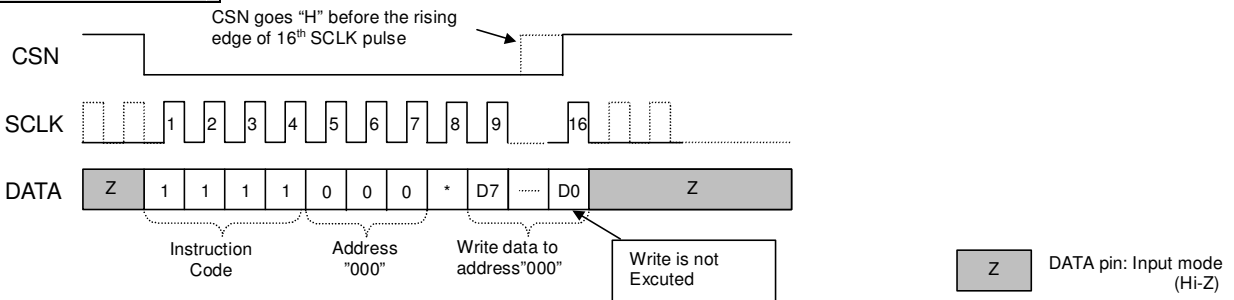

SERIAL ACCESS

Serial access with CSN staying "L" during the serie of write cycle.

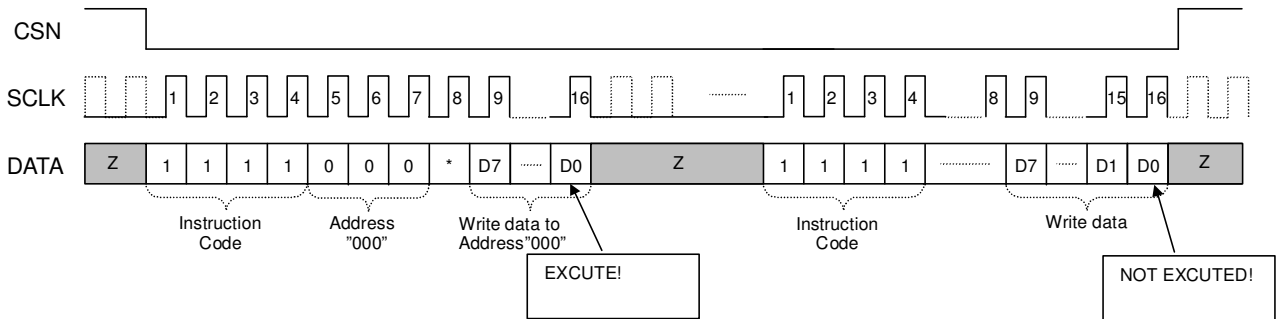

READ

CONTINUOUS SCLK

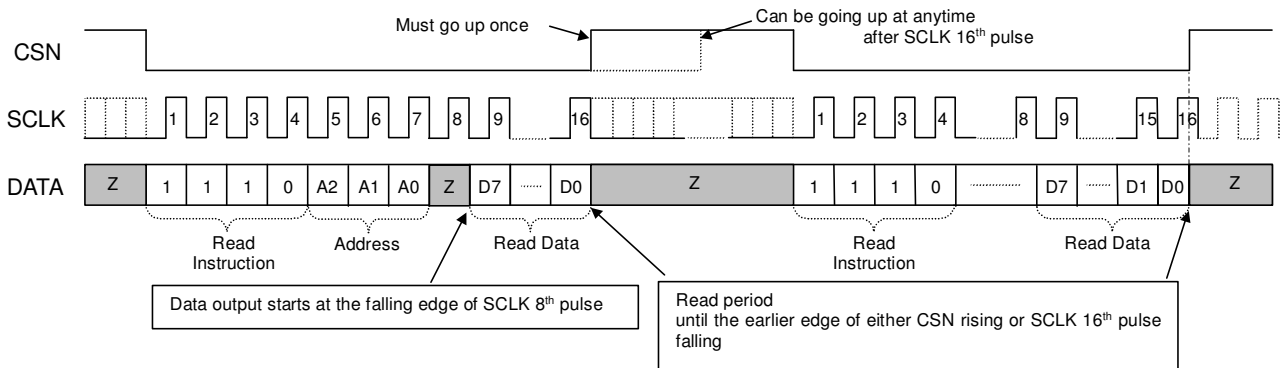

Burst SCLK

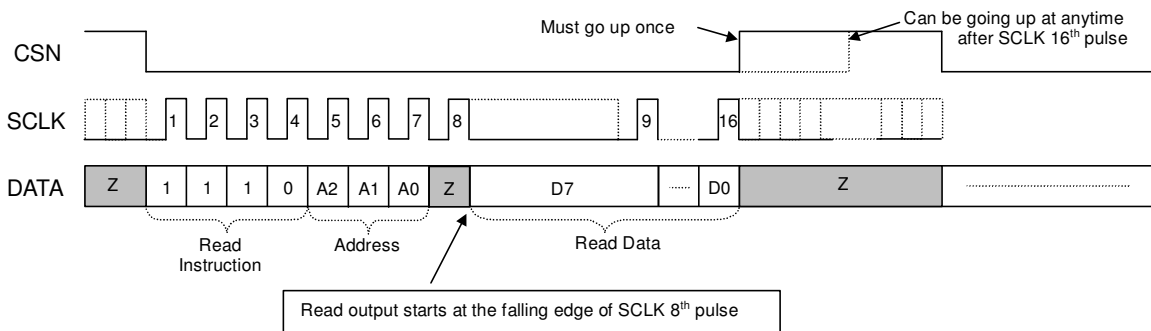

SERIAL ACCESS

Serial access with CSN staying "L" during the serie of read cycle.

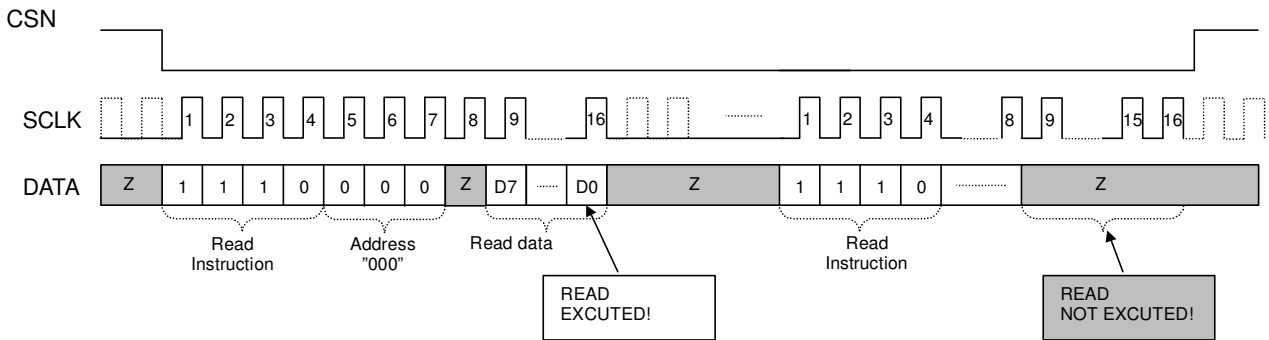

DISCORD OF INSTRUCTION CODE

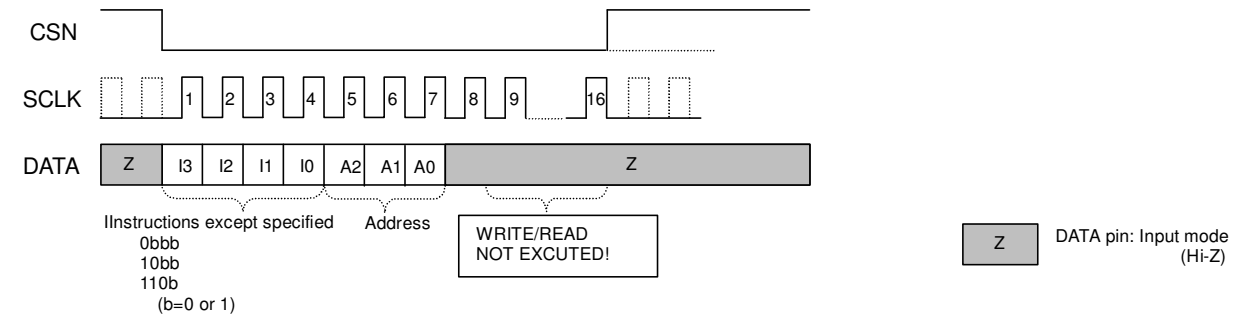

REGISTER MAP

Bit 11	Bit 10	Bit 9	Bit 8	Bit 7	Bit 6	Bit 5	Bit 4	Bit 3	Bit 2	Bit 1	Bit 0
A2	A1	A0	*	D7	D6	D5	D4	D3	D2	D1	D0
0	0	0	*	0	0	-	GA0R4	GA0R3	GA0R2	GA0R1	GA0R0
0	0	1	*	0	0	-	GA1R4	GA1R3	GA1R2	GA1R1	GA1R0
0	1	0	*	0	0	-	GA0T4	GA0T3	GA0T2	GA0T1	GA0T0
0	1	1	*	0	0	-	GA1T4	GA1T3	GA1T2	GA1T1	GA1T0
1	0	0	*	0	0	MTCH1	MTCH0	PD	PDTN	PDCH1	PDCH0
1	0	1	*	0	0	0	0	TNFQ	ALAWN	SEL2B	PCMIF
1	1	0	*	Reserved							
1	1	1	*	Reserved							

*)Dummy Bit

Note) All registers except address(000 - 011), Bit5(D5) can be read/write.

Note) Please write "all 0's" for address(000 - 100), Bit7,6(D7,D6) and address(101), Bit7,6,5,4(D7 - D4) for normal operation.

Note) Address(000 - 011),Bit5(D5) can not be write and "0" data will be output when it is accessed to read.

INITIALIZATION OF REGISTERS

The registers are initialized at POWER ON RESET only.

Power on reset may not be executed due to the difference of power up time constant. Thus it is highly recommended that all the register (address(000 – 101)) are to be written at the time of the power up and after the abnormal circumstances happens such as micro interrupt of the power line or mal operation due to lightning.

REGISTER FUNCTION

Address	Bit	Name	Default	Function	Refer
000	0	GA0R0	0	Receive gain adjustment on ch0 +6 to -18dB by 1.0dB step 00000: +6dB 11xxx: -18dB	
	1	GA0R1	1		
	2	GA0R2	1		
	3	GA0R3	0		
	4	GA0R4	0		
	5	-			
	6	0	0	Test mode Please write all "0".	
001	0	GA1R0	0	Receive gain adjustment on ch1 +6 to -18dB by 1.0dB step 00000: +6dB 11xxx: -18dB	
	1	GA1R1	1		
	2	GA1R2	1		
	3	GA1R3	0		
	4	GA1R4	0		
	5	-			
	6	0	0	Test mode Please write all "0".	
7	0	0			

Address	Bit	Name	Default	Function	Refer
010	0	GA0T0	0	Transmit gain adjustment on ch0 +6 to -18dB by 1.0dB step 00000: +6dB 11xxx: -18dB	
	1	GA0T1	1		
	2	GA0T2	1		
	3	GA0T3	0		
	4	GA0T4	0		
	5	-			
	6	0	0	Test mode Please write all "0".	
011	0	GA1T0	0	Transmit gain adjustment on ch1 +6 to -18dB by 1.0dB step 00000: +6dB 11xxx: -18dB	
	1	GA1T1	1		
	2	GA1T2	1		
	3	GA1T3	0		
	4	GA1T4	0		
	5	-			
	6	0	0	Test mode Please write all "0".	
100	0	PDCH0	0	CODEC CH0,1 Power down control 0: Power ON 1: Power OFF	
	1	PDCH1	0		
	2	PDTN	1	RING TONEGEN Power down control 0: Power ON 1: Power OFF	
	3	PD	0	Full Power down 0: Power ON 1: Power OFF	
	4	MTDX0	0	Mute control: VR0.VR1,DX pin 0: Normal output 1: Mute	
	5	MTDX1	0		
	6	0	0	Test mode Please write all "0".	
101	0	PCMIF	0	PCM Interface select 0: LF/SF 1: GCI	
	1	SEL2B	0	PCM data channel select 0: CH0 -> B1 1: CH1 -> B1	
	2	ALAWN	1	A/u-law select 0: A-law 1: u-law	
	3	TNFQ	0	Tone frequency select 0: 16Hz 1: 20Hz	
	4	0	0	Test mode Please write all "0".	
	5	0	0		
	6	0	0		
110	0		0	Reserved	
	1		0		
	2		0		
	3		0		
	4		0		
	5		0		
	6		0		
7		0			

Address	Bit	Name	Default	Function	Refer
111	0		0	Reserved	
	1		0		
	2		0		
	3		0		
	4		0		
	5		0		
	6		0		
	7		0		

ABSOLUTE MAXIMUM RATINGS

Parameter	Symbol	Min	Max	Units
Power Supply Voltages Analog/Digital Power Supply	VDD	-0.3	6.5	V
VSS Voltage	VSS	-0.1	0.1	V
Digital Input Voltage	VTD	-0.3	VDD+0.3	V
Analog Input Voltage	VTA	-0.3	VDD+0.3	V
Input current (except power supply pins)	IIN	-10	10	mA
Storage Temperature	Tstg	-55	125	°C

Warning: Exceeding absolute maximum ratings may cause permanent damage.

Normal operation is not guaranteed at these extremes.

RECOMMENDED OPERATING CONDITIONS

Parameter	Symbol	Min	Typ	Max	Units
Power Supplies Analog/Digital power supply(AK2306)	VDD	4.75	5.0	5.25	V
Power Supplies Analog/Digital power supply(AK2306 LV)	VDD	3.0	3.3	3.6	V
Ambient Operating Temperature	Ta	-40		85	°C
Frame Sync Frequency	FS		8		kHz

Note) All voltages reference to ground : VSS=0V

ELECTRICAL CHARACTERISTICS

Unless otherwise noted, guaranteed for VDD=+5V +/- 5%(AK2306), VDD=+3.3V +/- 0.3V(AK2306LV),
Ta = -40 ~ +85 °C, FS=8kHz.

DC Characteristics

Parameter	Symbol	Conditions	Min	Typ	Max	Units
Power Consumption	PDD1	PDCH0,1 PDDT0,1=0,0 All output unloaded		65		mW
BCLK=2048kHz	PDD2	PDCH0,1 PDDT0,1=1,0 All output unloaded		35		
Output High Voltage (CMOS level)	VOH	I _{OH} =-1.6mA	0.8VDD			V
Output Low Voltage (CMOS level)	VOL	I _{OL} =1.6mA			0.4	V
Input High Voltage1 (CMOS level)	VIH1		0.7VDD			V
Input High Voltage2 (TTL level)	VIH2		2.4			V
Input Low Voltage1 (CMOS level)	VIL1				0.3VDD	V
Input Low Voltage2 (TTL level)	VIL2				0.8	V
Input Leakage Current	I _I		-10		+10	uA
Input Capacitance	C _i				5	pF
Output Leakage Current	I _o	Tri-state mode	-10		+10	uA
Power Consump.@PD	PDDd		-	2.5	-	mW

Absolute Gain (AK2306: VDD=5.0V +/-5%, AK2306LV VDD=3.3V +/-0.3V)

Parameter	Conditions		Min	Typ	Max	Units
Analog Input Level	Input: 0dBm0@1020Hz	AK2306		0.849		Vrms
		AK2306LV		0.531		
Absolute Transmit Gain			-0.6	-	0.6	dB
Analog Output Level	Input: 0dBm0@1020Hz	AK2306		0.849		Vrms
		AK2306LV		0.531		
Absolute Receive Gain			-0.6	-	0.6	dB
Maximum Overload Level	+3.14dBm0	AK2306		1.219		Vrms
		AK2306LV		0.762		

Gain Tracking

Parameter	Conditions		Min	Typ	Max	Units
Transmit Gain Tracking Error	Reference Level: -10dBm0 1020Hz Tone	-55dBm0 ~-50dBm0	-1.2	-	1.2	dB
		-50dBm0 ~-40dBm0	-0.4	-	0.4	
		-40dBm0 ~ 3dBm0	-0.2	-	0.2	
Receive Gain Tracking Error	Reference Level: -10dBm0 1020Hz Tone	-55dBm0 ~-50dBm0	-1.2	-	1.2	dB
		-50dBm0 ~-40dBm0	-0.4	-	0.4	
		-40dBm0 ~ 3dBm0	-0.2	-	0.2	

Frequency Response

Parameter	Conditions		Min	Typ	Max	Units
Transmit Frequency Response	Relative to: 0dBm0@1020Hz	0.05kHz	-	-	-30	dB
		0.06kHz	-	-	-26	
		0.2kHz	-1.8	-	0	
		0.3 ~3.0kHz	-0.15	-	0.15	
		3.4kHz	-0.8	-	0	
		4.0kHz	-	-	-14	
Receive Frequency Response	Relative to: 0dBm0@1020Hz	0 ~3.0kHz	-0.15	-	0.15	dB
		3.4kHz	-0.8	-	0	
		4.0kHz	-	-	-14	

Distortion

Parameter	Conditions		Min	Typ	Max	Units
Transmit Signal to Distortion	1020Hz Tone	-40dBm0 ~-45dBm0	25	-	-	dB
		-30dBm0 ~-40dBm0	30	-	-	
		0dBm0 ~-30dBm0	36	-	-	
Receive Signal to Distortion	1020Hz Tone	-40dBm0 ~-45dBm0	25	-	-	dB
		-30dBm0 ~-40dBm0	30	-	-	
		0dBm0 ~-30dBm0	36	-	-	
Single Frequency Distortion Transmit			-	-	-46	dB
Single Frequency Distortion Receive			-	-	-46	dB
Intermodulation Distortion	-6dBm@860Hz,1380Hz		-	-	-42	dB

Note) C-message Weighted for u-Law, Psophometric Weighted for A-Law

Envelope delay Distortion

Parameter	Conditions	Min	Typ	Max	Units
Transmit Delay, Absolute	f =1600Hz	-	-	560	us
Transmit Delay, Relative Relative to f=1600Hz	f =500Hz ~600Hz	-	-	220	us
	f =600Hz ~1000Hz	-	-	145	
	f =1000Hz ~2600Hz	-	-	75	
	f =2600Hz ~2800Hz	-	-	105	
	f =2800Hz ~3000Hz	-	-	155	
Receive Delay, Absolute	f =1600Hz			450	us
Receive Delay, Relative Relative to f=1600Hz	f =500Hz ~1000Hz	-40	-	-	us
	f =1000Hz ~1600Hz	-30	-	-	
	f =1600Hz ~2600Hz	-	-	90	
	f =2600Hz ~2800Hz	-	-	125	
	f =2800Hz ~3000Hz	-	-	175	

Noise

Parameter	Conditions	Min	Typ	Max	Units	
Idle Channel Noise ¹⁾ A! D	u-law, C-message	-	5	10	dBrnC0	
	A-law, Psophometric	-	-85	-80	dBm0p	
Idle Channel Noise ²⁾ D! A	u-law, C-message	-	5	10	dBrnC0	
	A-law, Psophometric	-	-85	-80	dBm0p	
Noise, Single Frequency	VFXIN = 0 Vrms, DR = DX f=0 ~100kHz	-	-	-53	dBm0	
PSRR, Transmit	AVDD=DVDD=5V±100mVop f=0 ~50kHz	40	-	-	dB	
PSRR, Receive	AVDD=DVDD=5V±100mVop f=0 ~50kHz	40	-	-	dB	
Spurious Out-of-Band Signal at VRX Output ³⁾	0dBm0,	4.6 ~7.6kHz	-	-	-30	dB
	0.3 ~3.4kHz	7.6 ~8.4kHz	-	-	-40	
	PCM CODE	8.4 ~100kHz	-	-	-32	

Note 1) Analog Input = Analog Ground

Note 2) Digital Input(DR) = +0 Code

Note 3) Not tested in production Test. Parameters guaranteed by design.

Interchannel Crosstalk

Parameter	Conditions	Min	Typ	Max	Units
Transmit to Receive	0dBm0@VFXIN, Idle PCM code	-	-	-75	dB
Receive to Transmit	0dBm0 code level, VFXIN = 0 Vrms	-	-	-75	dB
Transmit to Transmit	0dBm0@VFXIN, Idle PCM code	-	-	-75	dB
Receive to Receive	0dBm0 code level, VFXIN = 0 Vrms	-	-	-75	dB

Analog Interface Transmit Amplifier

Parameter	Conditions	Min	Typ	Max	Units
Load Resistance		10	-	-	kohm
Load Capacitance		-	-	50	pF
Output voltage Swing	VDD=5V	-	3.6	-	Vp-p
	VDD=3.3V	-	2.25	-	

Analog Interface Receive Output (AK2306 : VDD 5.0V±5%, AK2306LV : VDD 3.3V±0.3V)

Parameter	Conditions		Min	Typ	Max	Units
Output voltage(AGND level)	+0 PCM code input	AK2306	2.3	2.4	2.5	V
		AK2306LV	-	1.5	-	
Load Resistance			10			kohm
Load Capacitance					50	pF
Output voltage Swing		AK2306	-	3.6	-	Vp-p
		AK2306LV	-	2.25	-	

Analog Interface Receive Output Amplifier

Parameter	Conditions		Min	Typ	Max	Units
Input Resistance			10	-	-	M ohm
Load Resistance			10	-	-	k ohm
Load Capacitance			-	-	50	pF
Output Voltage Swing		AK2306	-	3.6	-	Vp-p
		AK2306LV	-	2.25	-	

VOLUME (GA0T,GA0R,GA1T,GA1R)

Parameter	Pin	Conditions	Min	typ	max	Unit
Step margin		Relative to: 0dB	-1.0		+1.0*)	dB

*)Monotonous increase/decrease is guranteed

RING TONE GENERATOR

Parameter	Conditions	Min	typ	max	Unit
Signal frequency 16Hz/20Hz	No Jitter on FS 8KHz frame signal	-5%	16/20	+5%	Hz
Tone Duty	No Jitter on FS 8KHz frame signal	49	50	51	%

PCM INTERFACE (Long Frame, Short Frame, GCI)

Unless otherwise noted, the specification applies for TA = -40 to +85°C, VDD = 5V±5%/3.3V±0.3V, VSS = 0V and FS= 8kHz. All timing parameters are measured at VOH = 0.8VDD and VOL =0.4V.

Parameter	Symbol	Min	Typ	Max	Units	Ref Fig
FS Frequency	1/t _{PF}	-	8	-	kHz	Fig1 Fig2 Fig3
BCLK Frequency	1/t _{PB}	128		4096	kHz	
BCLK Pulse Width High	t _{WBH}	80			ns	
BCLK Pulse Width Low	t _{WBL}	80			ns	
Rising Time: (BCLK,FS,DX,DR)	t _R			40	ns	
Falling Time: (BCLK,FS,DX,DR)	t _F			40	ns	
Hold Time: BCLK Low to FS High	t _{HBF}	40			ns	
Setup Time: FS High to BCLK Low	t _{SFB}	70			ns	
Setup Time: DR to BCLK Low	t _{SDB}	40			ns	
Hold Time: BCLK Low to DR	t _{HBD}	40			ns	
Delay Time: BCLK High to DX valid Note1)	t _{DBD}			60	ns	
Long Frame						
Hold Time: 2 nd period of BCLK Low to FS Low	t _{HBFL}	40			ns	Fig1
Delay Time: FS or BCLK High, whichever is later, to DX valid Note1)	t _{DZFL}			60	ns	
Delay Time: BCLK Low to DX High-Z Note1)	t _{DZCL}	10		60	ns	
FS Pulse Width Low	t _{WFSL}	1			BCLK	
Short Frame						
Hold Time: BCLK Low to FS Low	t _{HBFS}	40			ns	Fig2
Setup Time: FS Low to BCLK Low	t _{SFBS}	40			ns	
Delay Time: BCLK Low to DX High-Z Note1)	t _{DZCS}	10		60	ns	
GCI						
BCLK Frequency	1/t _{PBG}	512		4096	kHz	Fig3
Delay Time: Second BCLK Low to DX High-Z	t _{DZCG}	10		60	ns	
Setup Time: DR to Second BCLK High	t _{SDBG}	40			ns	
Hold Time: Second BCLK High to DR	t _{HBDG}	40			ns	

Note1) Measured with 15pF Load capacitance and driving two LSTTLs

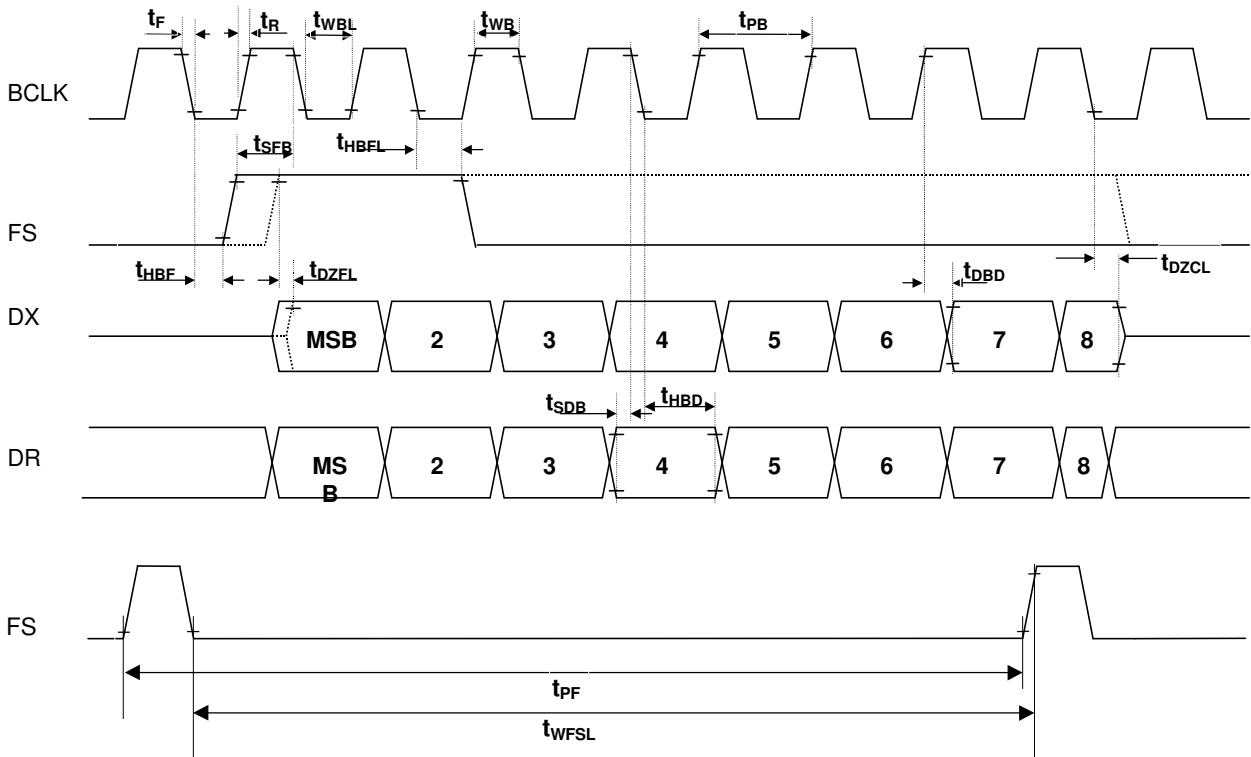

Fig1 PCM Interface Timing < Long Frame >

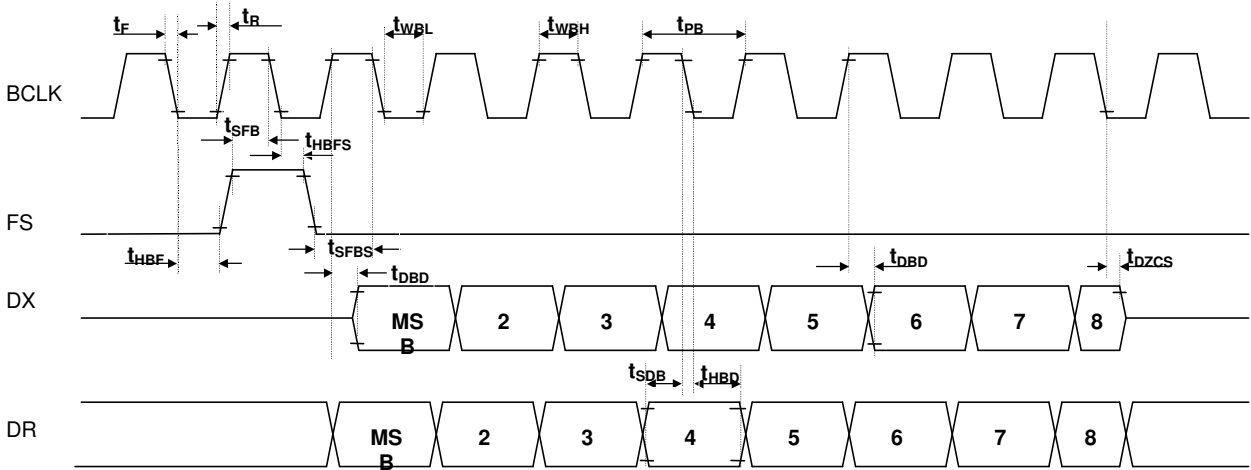

Fig2 PCM Interface Timing < Short Frame >

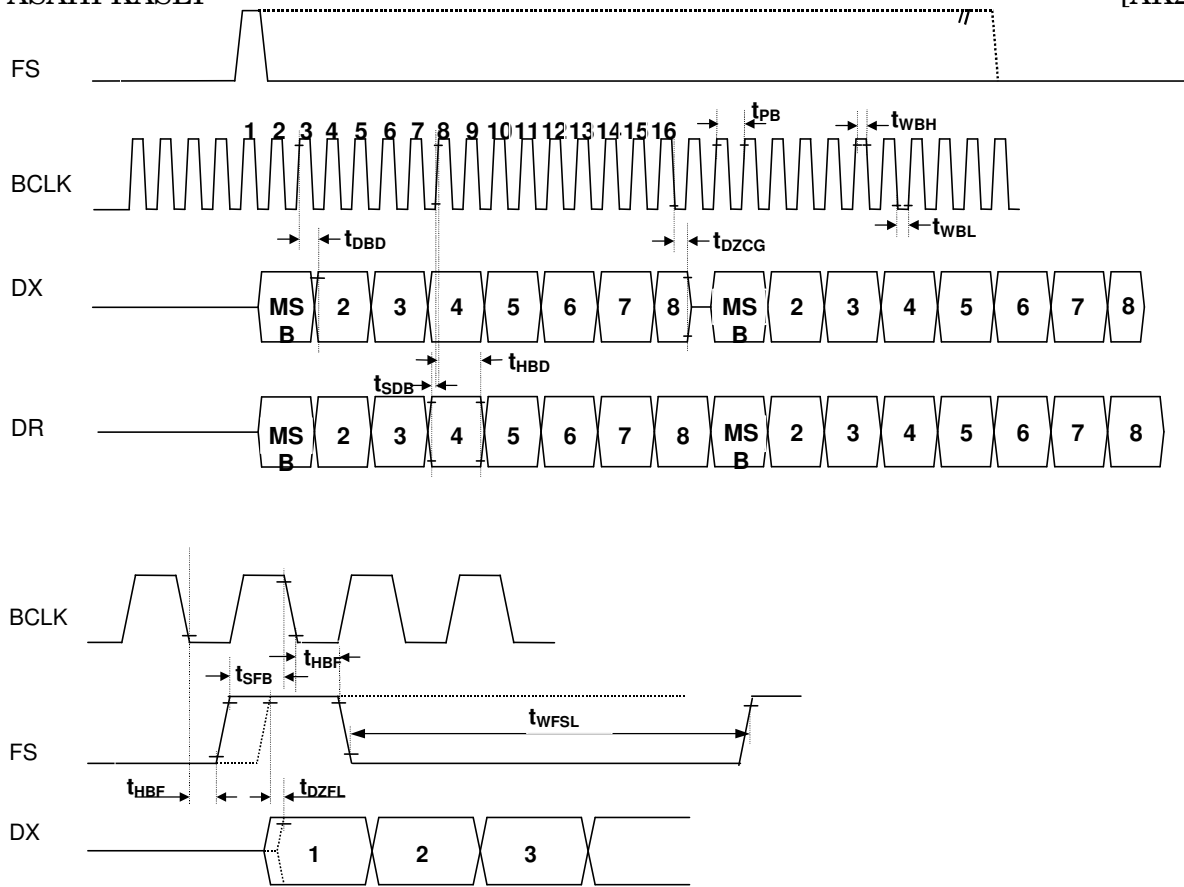

Fig3 PCM Interface Timing < GCI >

SERIAL INTERFACE

Parameter	Symbol	Min	Typ	Max	Units	Ref fig
SCLK Frequency	$1/t_{PSCLK}$			4	MHz	Fig4
SCLK Pulse Width High	t_{WSH}	40			ns	
SCLK Pulse Width Low	t_{WSL}	40			ns	
CSN Pulse Width Low	t_{WCL}	16			SCL K	
Hold Time: SCLK High to CSN Low	t_{HCS}	80			ns	
Setup Time: CSN Low to SCLK High	t_{SCS}	40			ns	
Rising Time: CSN,SCLK	t_R			100	ns	
Falling Time: CSN,SCLK	t_F			100	ns	
W R I T E						
Setup Time: DATA to SCLK High	t_{SDC}	40			ns	Fig4
Hold Time: SCLK High to DATA	t_{HDC}	40			ns	
Hold Time: SCLK Low to CSN High	t_{HCS2}	0			ns	
R E A D						
Delay Time: SCLK Low to DATA pin drive	t_{DDD}	0			ns	Fig5
Delay Time: SCLK Low to DATA valid	t_{DVD}			60	ns	
Delay Time: SCLK Low to DATA High-Z	t_{DZSD}	0		60	ns	Fig6
Delay Time: CSN High to DATA High-Z	t_{DZCD}	0		60	ns	
CSN Pulse Width High	t_{WCH}	40			ns	

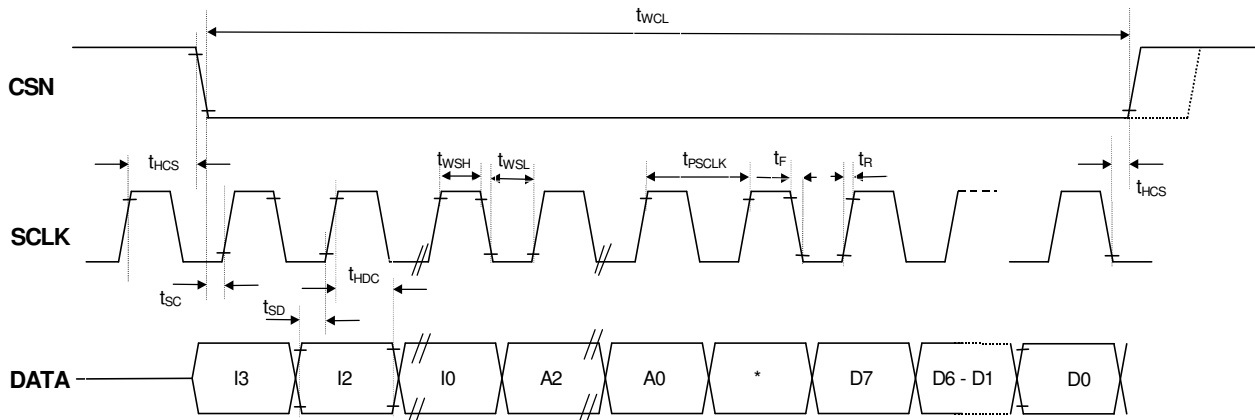

Fig4 Serial Interface Timing <WRITE>

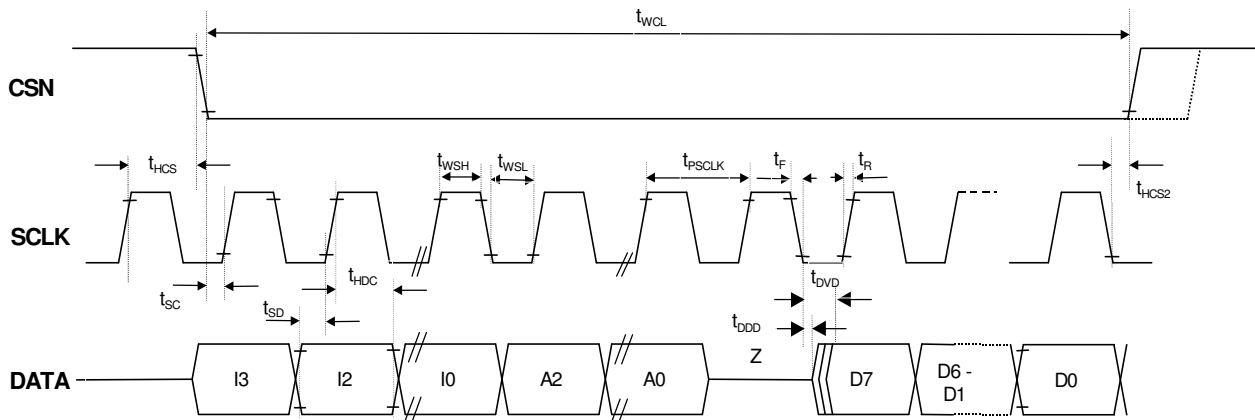

Fig5 Serial Interface Timing <READ>

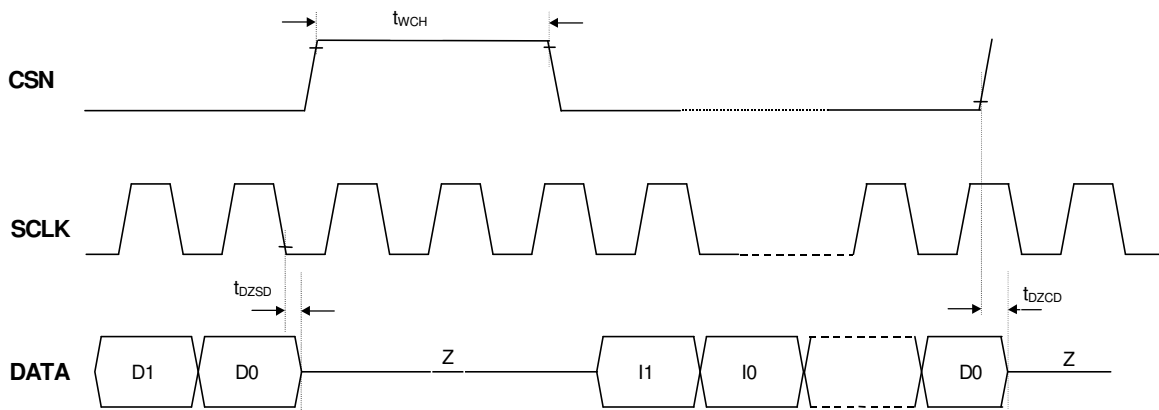

Fig6 Serial Interface Timing <READ>

APPLICATION CIRCUIT EXAMPLE

Analog input circuit(AMPT0,1)

AK2306/LV has an op-amp at analog input of each channel. Each op-amp can be used as a gain adjustment. Op-amp can be used as an inverting amplifier or differential input buffer with AMPRn as VREF buffer. Feedback resistor must be 10k ohm or larger.

Single End buffer

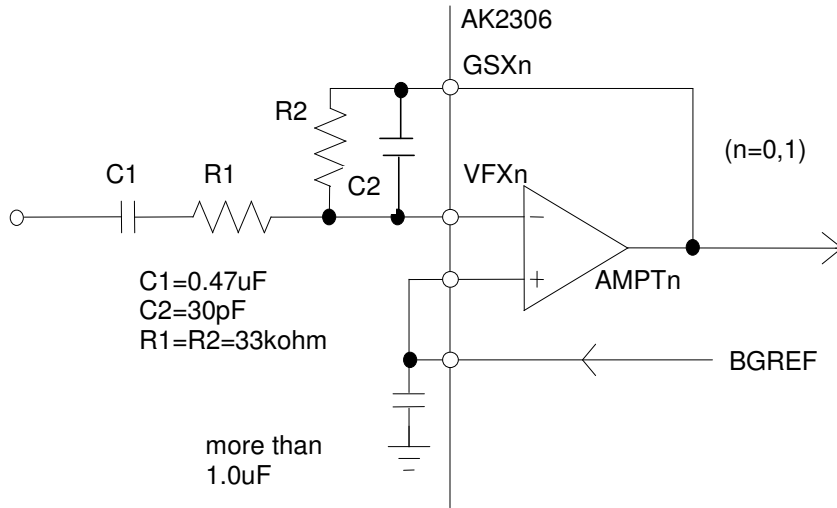

Differential buffer

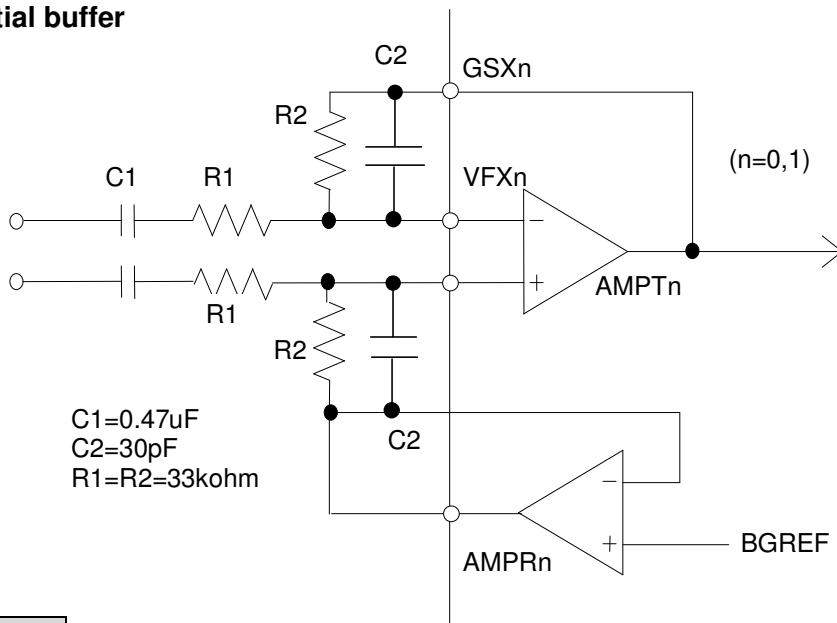

! Important Notice

Please use AMPRn as a AGND buffer to avoid a cross talk between TX and RX, channel1 and channel2 when TX input is composed as a differential input.

Analog output circuit(AMPR0,1)

AK2306/LV has an op-amp at analog output stage of each channel to consist in an inverting amplifier for a gain adjustment of 0dBm0 level. Feedback resistor must be 10kohm or larger.

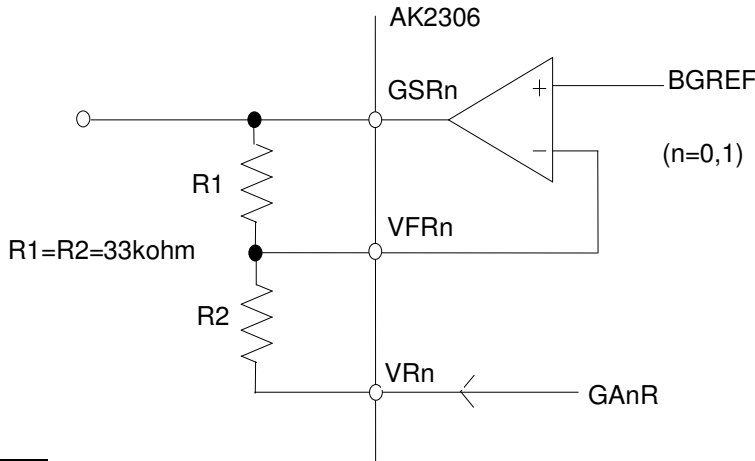

! Important Notice

When AMPRn are used as a AGND buffer, they can not be used for a gain adjustment.

Analog ground stabilization capacitor

An external capacitor of more than 1.0uF should be connected between VREF and VSS to stabilize analog ground (VREF).

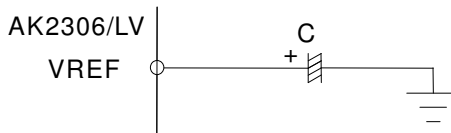

PLL Loop filter capacitor

An external capacitor of more than 0.22uF should be connected between LPC and VSS.

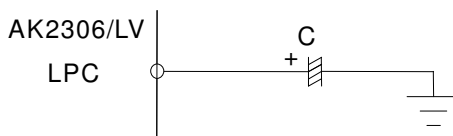

Power Supply

To attenuate the power supply noise, connect capacitors between VDD and VSS, as shown below.

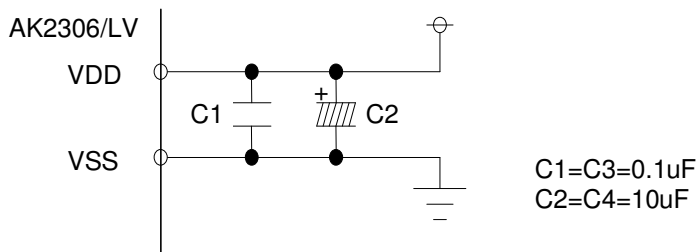

PACKAGE INFORMATION

- 24pin SSOP

Marking

XXXXX: Date Code Identifier

AK2306

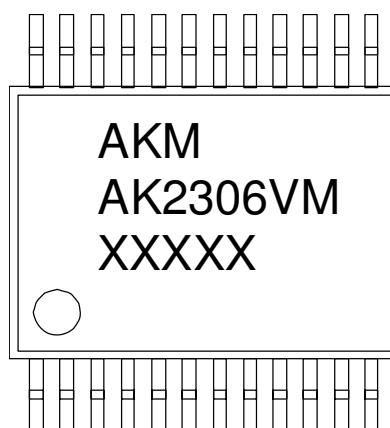

AK2306L

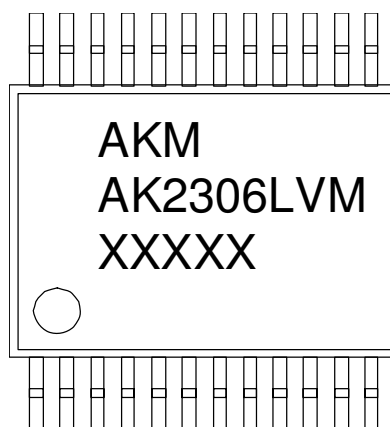

PACKAGE SIZE

24pin SSOP (Unit: mm)

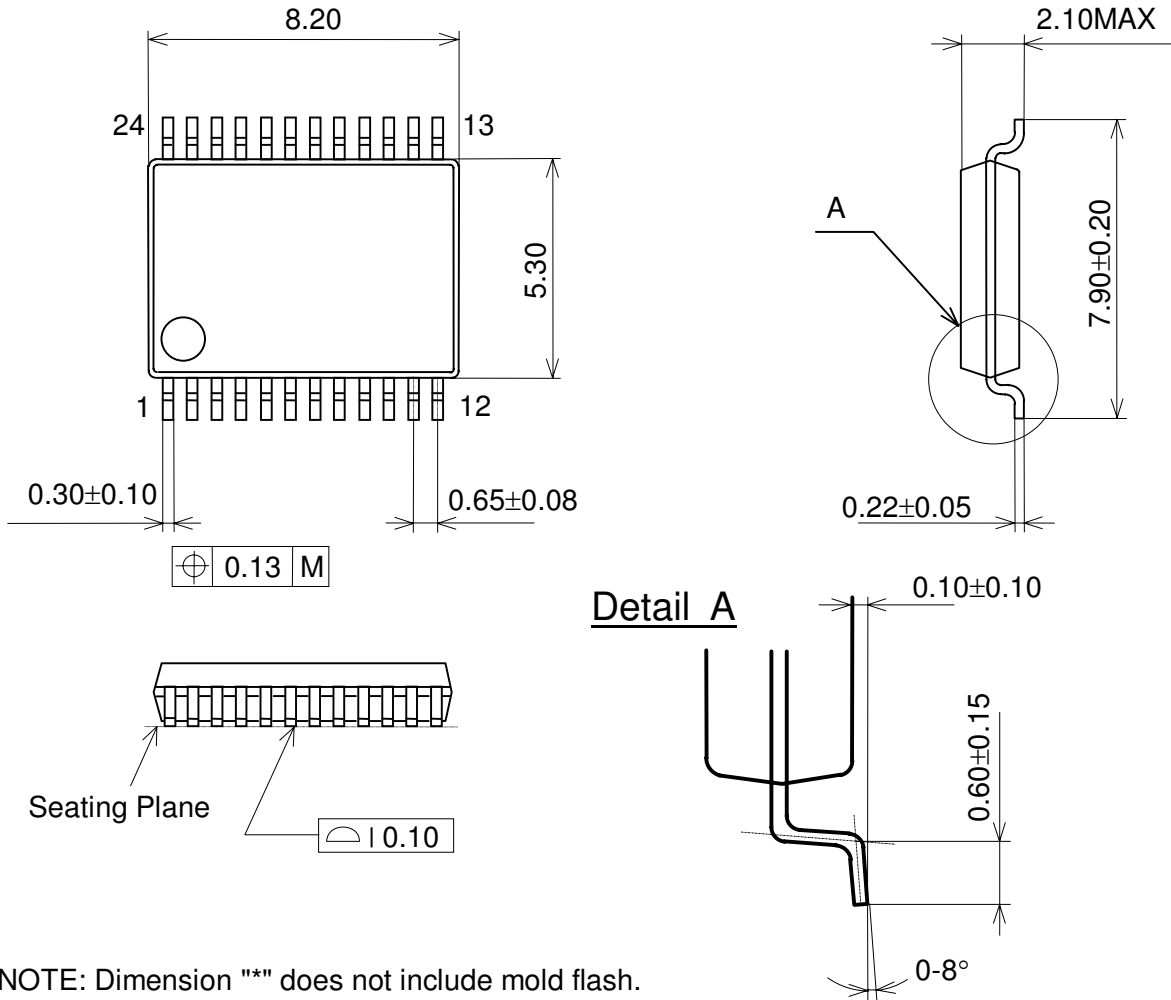

REVISION HISTORY

Date (Y/M/D)	Revision	Reason	Page	Contents
11/10/20	06	Specification Change	1, 36, 37	Package Change: (24pin VSOP) → (24pin SSOP) Marking diagrams were changed. Package drawing was changed.
12/01/25	07	Error Correction	36	PACKAGE INFORMATION Marking diagrams were changed

IMPORTANT NOTICE

- These products and their specifications are subject to change without notice.
When you consider any use or application of these products, please make inquiries the sales office of Asahi Kasei Microdevices Corporation (AKM) or authorized distributors as to current status of the products.
- Descriptions of external circuits, application circuits, software and other related information contained in this document are provided only to illustrate the operation and application examples of the semiconductor products. You are fully responsible for the incorporation of these external circuits, application circuits, software and other related information in the design of your equipments. AKM assumes no responsibility for any losses incurred by you or third parties arising from the use of these information herein. AKM assumes no liability for infringement of any patent, intellectual property, or other rights in the application or use of such information contained herein.
- Any export of these products, or devices or systems containing them, may require an export license or other official approval under the law and regulations of the country of export pertaining to customs and tariffs, currency exchange, or strategic materials.
- AKM products are neither intended nor authorized for use as critical components^{Note1)} in any safety, life support, or other hazard related device or system^{Note2)}, and AKM assumes no responsibility for such use, except for the use approved with the express written consent by Representative Director of AKM. As used here:
 - Note1) A critical component is one whose failure to function or perform may reasonably be expected to result, whether directly or indirectly, in the loss of the safety or effectiveness of the device or system containing it, and which must therefore meet very high standards of performance and reliability.
 - Note2) A hazard related device or system is one designed or intended for life support or maintenance of safety or for applications in medicine, aerospace, nuclear energy, or other fields, in which its failure to function or perform may reasonably be expected to result in loss of life or in significant injury or damage to person or property.
- It is the responsibility of the buyer or distributor of AKM products, who distributes, disposes of, or otherwise places the product with a third party, to notify such third party in advance of the above content and conditions, and the buyer or distributor agrees to assume any and all responsibility and liability for and hold AKM harmless from any and all claims arising from the use of said product in the absence of such notification.