



USB Interface Audio CODEC

Features:

- **USB Audio Controller**
 - 12 Mbps bit rate
 - USB Serial Interface Engine (SIE)
 - Audio Class Processing Block
 - 4 Endpoints
 - USB transceiver
- **16bit CODEC**
 - Single-channel A/D Converter
 - Microphone Pre-Amp (Fixed Gain: 20dB)
 - Mute/Volume Control
 - Programmable Gain Control
 - +24dB to -31dB (1dB step)
 - D/A Converter
 - 2 channels
 - Mixer
 - Mute/Attenuation Control
 - +0dB to -47dB (1dB step)
 - Analog Bass Boost
- **HID Support**
 - remote control of playback volume/mute
 - recording mute/status function
- **Power Management**
 - control of external headphone amplifier
 - low power at suspend mode (< 1uA)
- **EEPROM Interface (Microwire Interface)**
 - can read Device/String Descriptor from EEPROM
 - 1K/2K/4K bit EEPROM
- **On-chip PLL**
 - 7 sampling frequencies:
 - 8kHz, 11.025kHz, 16kHz, 22.05kHz, 32kHz,
 - 44.1kHz, 48kHz
- **Single Power Supply, Low Power**
 - +3.3Volts±0.3V
- **Package**
 - 48pin LQFP

General Description:

The AK4571 is a USB Interface audio CODEC. The AK4571 incorporates a 16-bit CODEC, PLLs, USB transceiver, SIE (serial interface engine), audio class processing unit, FIFO and other required signals into a single chip. The AK4571 can simultaneously transmit and receive audio stream data through USB bus. In addition to this, the single-channel ADC and 2-channel DAC can operate at different sampling rates.

The AK4571 has a programmable gain amplifier for analog input (IPGA). The gain range is from -31dB to +24dB with 1dB steps. In addition to the IPGA, the AK4571 also has a fixed +20dB pre-amplifier. Analog input signals can be mixed directly with the D/A signal and sent to the LINEOUT pins of the chip.

The analog outputs of the AK4571 can be attenuated up to -47dB in 1dB steps. The AK4571 also has an analog bass boost circuit. Bass Boost response can be modified by changing the values of external resistors and capacitors.

The AK4571 has a Human Interface Device function that allows a user to control the playback volume at the device side. The playback volume on mixer applet moves up or down automatically by the operation of HID buttons. The AK4571 also can mute analog input signal locally in addition to mixer applet control.

The AK4571 has advanced power management capabilities. Suspend current is less than 1uA. The AK4571 can also control the power of an external headphone amplifier to conform to the USB suspend current requirement of 500uA maximum.

The AK4571 has a Microwire interface for an external EEPROM, allowing customization of Vendor ID and product ID.

The high integration of the AK4571 reduces both the number of external components required and the PCB area required to build USB devices, including small format products such as USB headsets.



Block Diagram

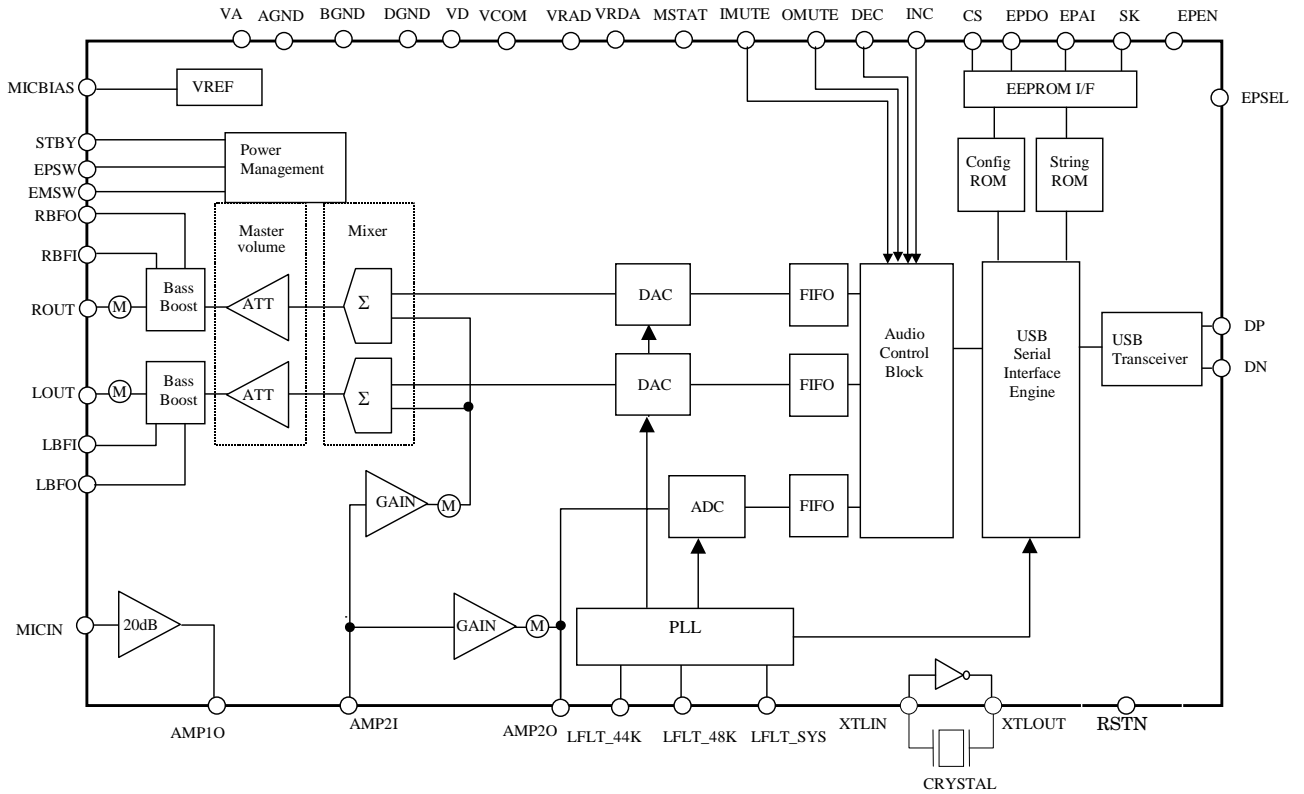

Ordering Guide

AK4571VQ 0 ~ +70°C 48pinLQFP(0.5mm pitch)
 AKD4571 Evaluation Board for AK4571

Pin Layout

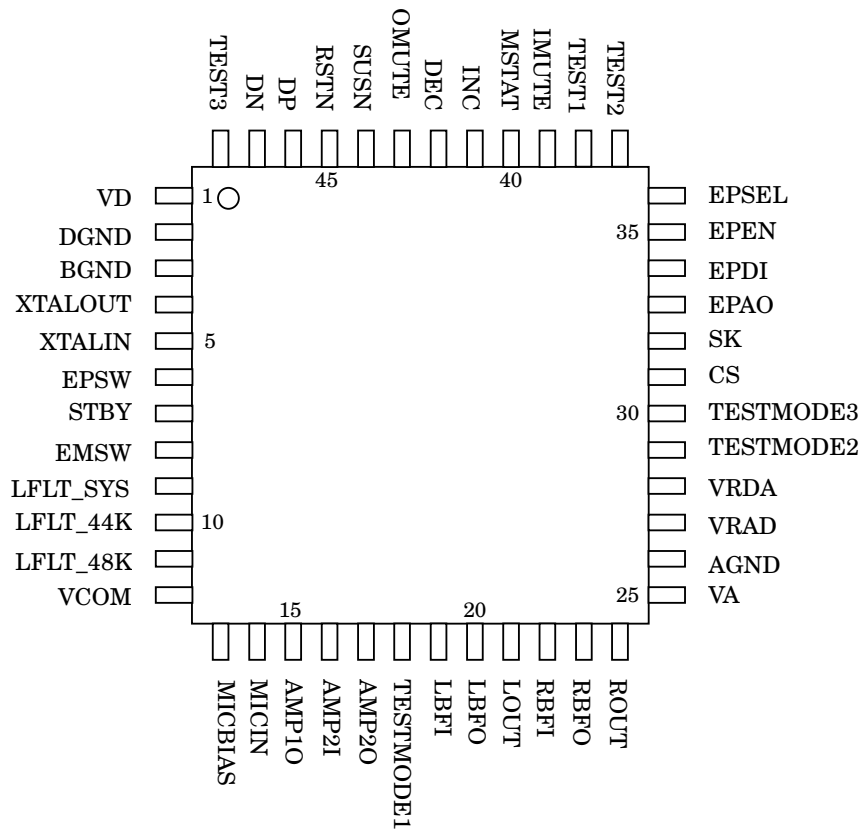

Pin/Function				
No.	Signal Name	I/O	Ana / Dig	Description
USB Interface				
46	DP	I/O	D	USB bus Non-Inverting pin. Since the AK4571 is a full-speed device, a 1.5kΩ resistor must be connected between D+ node to VD.
47	DN	I/O	D	USB bus Inverting Pin.
Reset, Crystal, PLL				
45	RSTN	I	D	Reset Pin. Low input resets the chip. Schmitt Trigger input.
44	SUSN	O	D	Suspend Pin "L": Suspend Mode "H": Normal Mode
4	XTALOUT	O	A	Crystal Oscillator Output, Connect Crystal Resonator. Connect capacitor
5	XTALIN	I	A	Crystal Oscillator Input, Connect Crystal Resonator. Connect capacitor
9	LFLT_SYS	O	A	System PLL loop filter Pin. Connect 2.7kΩ resistor and 22nF capacitor in series externally.
10	LFLT_44K	O	A	Codec PLL loop filter Pin. Connect 120kΩ resistor and 6.8nF capacitor in series externally.
11	LFLT_48K	O	A	Codec PLL loop filter Pin. Connect 120kΩ resistor and 6.8nF capacitor in series externally.
Analog Input/Output				
12	VCOM	O	A	Analog Common Voltage Reference Pin
27	VRAD	O	A	ADC Common Voltage Reference Pin.
28	VRDA	O	A	ADC Common Voltage Reference Pin.
14	MICIN	I	A	Mono Channel Microphone Input
15	AMP1O	O	A	Mono Channel 1 st Amplifier Output Pin
16	AMP2I	I	A	Mono Channel 2 nd Amplifier Input Pin
17	AMP2O	O	A	Mono Channel 2 nd Amplifier Output Pin Please Connect 1nF capacitor.
21	LOUT	O	A	Left Channel D/A Out
24	ROUT	O	A	Right Channel D/A Out
19	LBFI	I	A	Left Channel Bass Boost Filter Input Pin
20	LBFO	O	A	Left Channel Bass Boost Filter Output Pin
22	RBFI	I	A	Right Channel Bass Boost Filter Input Pin
23	RBFO	O	A	Right Channel Bass Boost Filter Input Pin
13	MICBIAS	O	A	Voltage Reference Output for the Microphone's bias voltage When the chip goes into Suspend mode, this pin goes to Hi-Z.
External Headphone Amplifier Control				
6	EPSW	O		External Headphone Amplifier Power Switch Control Pin 1 "H": Normal Operation "L": Suspend Mode
7	STBY	O		External Headphone Amplifier Power Switch Control Pin 2 "L": Normal Operation "H": Suspend Mode
8	EMSW	O		External Headphone Amplifier Mute Control Pin "H": MUTE ON "L": MUTE OFF

No.	Signal Name	I/O	Ana / Dig	Description
EEPROM I/F				
31	CS	O	D	EEPROM I/F Chip Select Pin
32	SK	O	D	Read Clock Pin
34	EPDI	I	D	EEPROM Data Input Pin
33	EPAO	O	D	EEPROM Address Output Pin
35	EPEN	I	D	EEPROM Enable Pin "H": Read Device/String Descriptor from external EEPROM "L": Read Device/String Descriptor from internal ROM. CS,SK,EPDI,EPAO are Hi-Z
36	EPSEL	I	D	EEPROM Select "L": 1Kbit Type EEPROM is connected. "H": 2Kbit/4Kbit EEPROM is connected
HID Interface				
39	IMUTE	I	D	A/D Mute Toggles mute status at the rising edge. If this pin is not used, please connect this pin to DGND.
43	OMUTE	I	D	D/A Mute Sets "1" to internal register at the rising edge, and reset to "0" at the falling edge. If this pin is not used, please connect this pin to DGND.
41	INC	I	D	D/A Volume Up Pin Sets "1" to internal register at the rising edge, and reset to "0" at the falling edge. If this pin is not used, please connect this pin to DGND.
42	DEC	I	D	D/A Volume Down Pin Sets "1" to internal register at the rising edge, and reset to "0" at the falling edge. If this pin is not used, please connect this pin to DGND.
40	MSTAT	O	D	Recording Mute Status Pin. "H": Mute ON "L": Mute OFF In suspend mode, this pin is "L".
Power Supply				
25	VA	P	A	Analog Power Supply, 3.3V
26	AGND	P	A	Analog Ground
1	VD	P	D	Digital Power Supply, 3.3V
2	DGND	P	D	Digital Ground
3	BGND	P	D	Bulk Ground, 0V
Test Mode				
18	TESTMODE1	I		Please tie down to AGND for normal operation.
29	TESTMODE2	I		Please tie down to AGND for normal operation.
30	TESTMODE3	I		Please tie down to AGND for normal operation.
38	TEST1	I		Please tie down to DGND for normal operation.
37	TEST2	O		Please open state
48	TEST3	I		Please tie down to DGND for normal operation.

Absolute Maximum Rating

AGND, DGND=0V

Parameter	Symbol	min	Max	Units
Power Supplies	Analog VA	-0.3	4.5	V
	Digital VD	-0.3	4.5	V
	DGND-AGND ΔGND		0.3	V
Input Current (any pins except for supplies)	IIN	-	±10	mA
Analog Input Voltage	VINA	-0.3	VA+0.3	V
Digital Input Voltage	VIND	-0.3	VD+0.3	V
Ambient Temperature	Ta	0	70	°C
Storage Temperature	Tstg	-40	125	°C

Note 1. All voltages with respect to ground

Warning: Operation at or beyond these limits may result in permanent damage to the device. Normal operation is not guaranteed at these extremes.

Recommended Operating Condition

AGND, DGND=0V

Parameter	Symbol	min	typ	Max	Units
Power Supplies	Analog VA	3.0	3.3	3.6	V
	Digital VD	3.0	3.3	3.6	V

All voltages with respect to ground.

* AKM assumes no responsibility for usage beyond the conditions set forth in this datasheet.

Analog Characteristics

Ta=25°C, VA=VD=3.3V, Signal Frequency=1kHz, Sampling Frequency Fs=44.1kHz BW=20Hz – 20kHz, TEST mode; unless otherwise specified

Parameter	Min	typ	Max	Units
Mono ADC (1 channel)				
Resolution			16	bits
S/N (A weight) @44.1kHz (PGA is set to 0dB) AMP2I input : USB Normal mode		83		dB
S/(N+D) (-1.0dB analog input) USB Normal mode		73		dB
Full scale input Voltage	0.53	0.6	0.67	Vrms
MIC amplifier				
S/N (A weight) MICIN input AMP1O output	76	84		dB
Gain 20dB Selected	+17	+20	+23	dB
Input Impedance	10	20		kΩ
Stereo DAC (2 channel)				
Resolution			16	bits
S/N (A weight) @44.1kHz (DAC volume & master volume is set to 0dB) USB Normal mode		84		dB
S/(N+D) (-1.0dB digital input) USB Normal mode		75		dB
Full scale output Voltage	0.53	0.6	0.67	Vrms
PGA				
Step size	0	1.0	2.0	dB
Attenuation control range	-31		+24	dB
Input Impedance AMP2I input	10	20		kΩ
Master volume:				
step size	0	1.0	2.0	dB
Attenuation control range	-47		0	dB
Output Load Resistance	10			kΩ
Output Load Capacitance			5	pF
Bass Boost				
Internal Resistance		40		kΩ
External Resistance		360	400	kΩ
External Capacitance			5	pF
MIC Bias (Buffer Amp)				
Output Voltage	1.94	2.2	2.46	Vdc
Output Current			2	mA
Power Supplies				
Analogue		35	52	mA
Digital		15	23	mA
Total		50	75	mA
Power Down(Suspend)		0	150	uA

Filter Characteristics

Ta=25°C, VA=VD=3.3V, fs=44.1kHz

Parameter	min	typ	max	Units
ADC Digital Filter (Decimation LPF)				
Pass band (± 0.2 dB)	0		17.64	kHz
Stop band	26.5			kHz
Stop band Attenuation	70			dB
Group Delay		0.363		ms
ADC Digital Filter (HPF)				
Frequency Response: -3dB		6.89		Hz
-0.5dB		19.3		
-0.1dB		44.9		
DAC Digital Filter				
Pass band (± 0.2 dB)	0		17.64	kHz
Stop band	26.5			kHz
Stop band Attenuation	70			dB
Group Delay		0.312		ms
DAC Analog Post filter				
Pass band Frequency Response	-	± 0.1	-	dB

Digital DC Characteristics

Ta=0 - 70°C; VD=3.0 - 3.6V; DGND=0V Measurement under static state

All digital pins except DP, DN. Schmitt hysteresis level of RSTN pin and levels of all test pins will not be tested.

Parameter	Symbol	Min	Typ	Max	Units
EPDI,EPEN, EPSEL, pin "H" level input voltage	VIH	70%VD			V
EPDI, EPEN, EPSEL pin "L" level input voltage	VIL			30%VD	V
RSTN pin "H" level voltage	VIHR	2.4			V
RSTN pin "L" level voltage	VILR			0.8	V
IMUTE, OMUTE, INC, DEC pin "H" level voltage	VIHR	2.4			V
IMUTE, OMUTE, INC, DEC pin "L" level voltage	VILR			0.8	V
SUSN, EPSW, STBY, EMSW, MSTAT pin "H" level output voltage IOH= 2mA	VOH	2.4			V
SUSN, EPSW, STBY, EMSW, MSTAT pin "L" level output voltage IOL= -2mA	VOL			0.6	V
CS, SK, EPAO pin "H" level output voltage IOH= 2mA	VOH	2.4			V
CS, SK, EPAO pin "L" level output voltage IOL= -2mA	VOL			0.6	V
DP, DN Single Ended Receiver Threshold for "H" level	VIHR	2.0			V
DP, DN Single Ended Receiver Threshold for pin "L" level	VILR			0.8	V
Input Leakage Current	Iin			±10	μA
Pull down Resistance (only EPDI pin)@3.3V Ta=25°C	Rpd		100		kΩ

Switching Characteristics

Ta=25°C, VA=VD=3.3V

Parameter	Symbol	Min	Typ	Max	Units
Master Clock Frequency	MCLK	-	12.000	-	MHz
Reset input width @RSTN pin(low active)	Wrst	1.0			us
Time Width for USB Reset Signal Recognition DP<VseL & DN< VseL to USB Reset mode	Trst_rec	3.0			μs
Device Ready Time from USB Reset After releasing from USB Reset to Device Ready (Transaction can start)	Tdrr			10	ms
Time Width for Suspend Recognition Idle state (DP > VseL & DN < VseL) to Suspend mode	Tsus_rec	4.36			ms
Resume Time from Suspend First flip of DP/DN from Idle state To Device Ready*)	Tresm			30	ms
Imute input width with @IMUTE pin(High active)	Wimute	10.005			ms
Omute,Dec,Inc input width with @OMUTE,DEC,INC pin (High active)	Wodi	2.001			ms

Device Ready: VREF, X'tal oscillator and PLL are stable and standard bus transactions can proceed

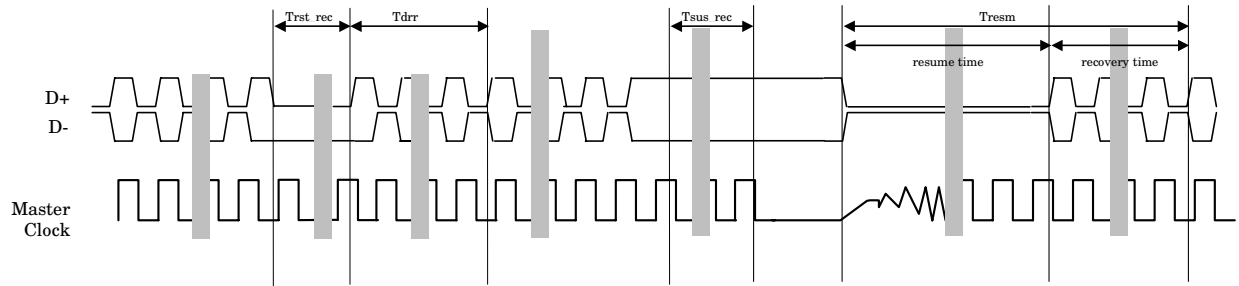

Figure 1. Mode Change with respect to Bus States

Transmitter/Receiver Characteristics							
Ta=25°C; VD=3.3V; DGND=0V; CL=50pF							
Parameter	Symbol	Pins	Conditions	Min	Typ	Max	Units
Transmitter							
Data Rate	DR	DP, DN		11.97	12	12.03	MHz
Output Impedance (Hi)	Roh	DP, DN	DP, DN="H" at Iout = -10mA		36		Ω
Output Impedance (Lo)	Rol	DP, DP	DP, DN="L" at Iout = 10mA		36		Ω
"H" level Output Voltage	Vohd	DP, DN	at Iout = -200uA	2.8			V
"L" level Output Voltage	Vold	DP, DN	at Iout = 2.2mA			0.3	V
Tri-state Leakage Current	Iolk	DP, DN	0 < DP, DN < 3.3V	-10		10	μA
Rise/Fall Time	Trf/Tff	DP, DN		4	10	20	ns
Rise/Fall Time Matching	Trfm	DP, DN			100		%
Crossover Point	Vcrs	DP, DN			1.65		V
Receiver							
Input Common Mode range	CMR	DP, DN		0.8		2.5	V
Differential Input Level	Vdiff	DP, DN	DP - DN	0.2			V

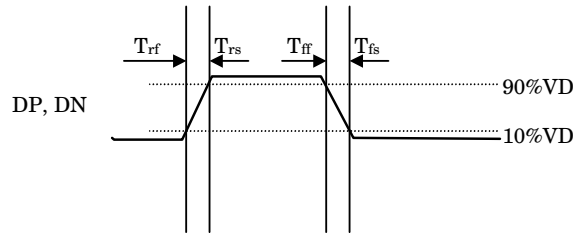

Figure 2. Rise/Fall Time

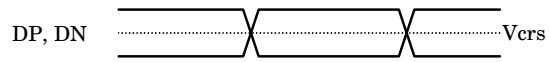

Figure 3. Crossover Point

1 Device Overview

1.1 PLL and Sampling Rates

The AK4571 has three PLLs in addition to a crystal oscillation circuit. The first PLL generates a system clock at 48MHz, the second PLL generates the clock for 44.1kHz sample rates (including derivatives of this sample rate) and third PLL generates the clock for 48kHz sample rates (including derivatives).

The CODEC clocks are generated from the USB SOF, so they are synchronized with USB SOF. The ADC and DAC operate at one of seven sampling rates, 8kHz, 11.025kHz, 16kHz, 22.05kHz, 32kHz, 44.1kHz, and 48kHz. The ADC and DAC can operate at different sampling rates.

1.2 A/D Converter & D/A Converter

The AK4571 has a 16-bit single-channel A/D converter, and a 16-bit two-channel D/A converter. The AK4571 has a programmable gain amplifier for the analog input (IPGA) with a range from -31dB to +24dB in 1dB steps. In addition to the IPGA, the AK4571 has a fixed 20dB gain pre-amplifier. Therefore the total gain of the analog input is +44dB maximum. Analog output can be attenuated from 0dB to 47dB in 1dB steps. Analog input and the D/A signal can be mixed in the chip and sent to the Line outputs. The Lineout volume, the microphone playback volume, and the microphone recording volume can be controlled directly from the PC

1.3 Bass Boost Control

The AK4571 has an analog bass boost circuit, and can boost the bass frequencies of the lineout signal by up to 20dB. Frequency response and DC gain are adjusted by external resistors and capacitors. The Bass boost effect is controlled via the HID application.

1.4 Serial Interface Engine (SIE) & Audio Class Processing Block

The AK4571 has a Serial Interface Engine that processes lower-level protocols like CRC checking, bit stuffing, NRZI encoding/decoding, in addition to higher-level protocol like USB standard requests. SIE also notifies the backend that it has received an Audio Class Request, and passes the request to the backend. The backend decodes and processes Audio Class Request like mute requests, volume requests and sampling frequency control requests. Therefore, the AK4571 does not require a micro-controller for this processing.

1.5 HID (Human Interface Device)

Since the AK4571 supports HID function, mute and volume can be controlled remotely. The host knows whether the playback volume/mute button has been pressed or not by issuing an Interrupt Request periodically, and notifies the application that the status has changed. The software application issues the volume/mute request in order to synchronize the software with the AK4571. Input/Recording signals can be also muted independently of the software application.

1.6 EEPROM I/F

The AK4571 has all of its descriptors in its internal ROM, so it does not require external an EEPROM. However vendor ID, vendor name, product ID, and product name can be also customized by using an external Microwire interface EEPROM. A Microwire™ type, 1K, 2K, or 4K EEPROM can be used.

1.7 Power Management

The AK4571 starts its transition to suspend mode when the idle state of USB bus continues more than 3ms. The AK4571 suppresses the power-supply current (typ.1uA) while in suspend mode because all blocks, including PLLs, are placed in power-down mode. Under normal operation the AK4571 supplies a bias voltage via the output buffer to the microphone. In suspend mode, the MICBIAS pin goes to a Hi-Z state, and the AK4571 does not supply this current to the microphone.

The AK4571 also has 3 pins for control of an external headphone amplifier. These pins are used to suppress the power-supply current during suspend mode in addition to suppressing “pop noise” during the transition of suspend/resume. The AK4571 has two pins for power-control because there are “active high” types and “active low” types of external headphone amplifiers. Third pin is for the mute control to suppress transitional pop noise.

The USB bus consumes 200uA current even in suspend mode. A regulator also consumes current in standby mode. Even with these devices consuming power the system can still conform to the 500uA USB specification because of the AK4571 low-power consumption and its control of the microphone and headphone power circuits.

The AK4571 is ready for operation 30ms after transitioning from suspend mode to normal operating mode.

1.8 USB Transceiver

The AK4571 includes a USB transceiver.

2 Functional Description

2.1 Synchronization of the host and the AK4571

The ADC and DAC in the AK4571 operate synchronously with the SOF (Start of frame) of the USB bus. USB's Isochronous transfer guarantees that audio stream data is transferred once per frame. However, USB does not specify the start point of the transfer in a frame. The worst-case period between two transfers is about 2ms, therefore the AK4571 has a FIFO that stores 2ms audio stream data.

If the CODEC operates at 44.1kHz sampling frequency, the AK4571 expects that 45 samples are transferred once per 10 frames. (Please see Figure 4)

The average sampling frequency in Figure 4 is 44.1kHz.

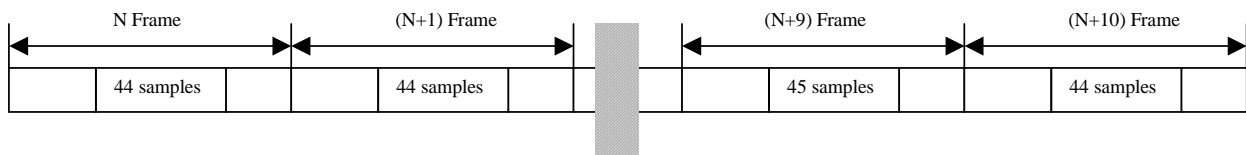

Figure 4 Synchronization Scheme

The AK4571 transmits all A/D data stored to FIFO in the previous frame while updating the A/D data to FIFO in the current frame. The sample count of 48kHz series D/A data per frame is fixed in all frames. For 44.1kHz, the appearance of 45 samples should be just one time per 10 frames. If the D/A clock and SOF clock operated asynchronously, the FIFO would overrun or underrun, and an audible pop noise would occur periodically. Therefore, CODEC clocks are synchronized with SOF clock. In order to achieve this synchronization, the AK4571 has built-in two PLLs for CODEC clocks and generates clocks for both of 48kHz sample rate series and 44.1 sample rate series.

2.2 Power Management

USB devices fall into one of three power categories: 1) Low-power Bus-powered Devices (<100mA) 2) High-power Bus-powered Devices (>100mA, <500mA) 3) Self-powered Devices.

As the AK4571 is a low-power consumption device, it can be defined as a Low-power Bus-powered Device and can be connected to a bus-powered Hub. (High-power Bus-powered Devices can't be connected to a Bus-powered Hub)

USB specifications require a maximum of 500µA in suspend mode. This includes the current drawn between Vbus and ground through the 1.5 k ohm resistor tied to D+ line and Vbus. This current is about 200µA.

Two points should be considered in order to observe the USB suspend mode specification.

- a) Suppression of the AK4571 current
 - All blocks including ADC, DAC, PLL go to power-down mode when the idle state continues for more than 3ms. Values like volume and mute status are preserved in suspend mode.
- b) Control of External Circuits
 - The USB specification does not permit more than 500µA of current in suspend mode. Therefore, the AK4571 must control the power dissipation of the external headphone amplifier and microphone. Since the MICBIAS pin is in a Hi-Z state in suspend mode, the AK4571 does not supply current to the microphone.

Headphone Amplifiers commonly have power-down pin and can be controlled externally. There are two types of power-control logic; active-low and active-high. Some headphone amplifiers have a mute pin for suppressing pop noise. The AK4571 supports all of these headphone amplifiers.

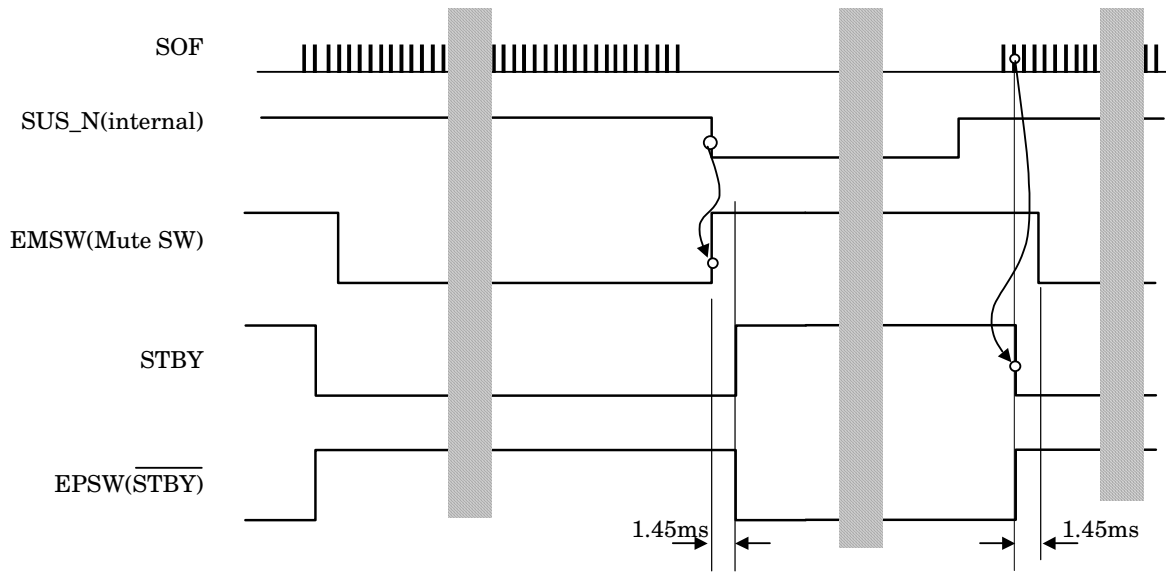

Figure 5 Suspend and Resume Sequence

2.3 Bias Circuit for Microphone

The AK4571 supplies a bias voltage to the microphone through the MICBIAS pin. The output voltage is about 2.2 volts and output current is 2mA maximum. Since the microphone's output signal level is very low, the noise level of the bias voltage should also be low. USB bus transactions typically cause variation of the regulator's output. However, the AK4571 has a built-in voltage reference for mic bias, and suppresses the bias noise caused by the regulator.

Coupling capacitors should be connected in parallel between the two resistors (i.e. $R_a=300\Omega$, and $R_b=4.7k\Omega/2.2k\Omega$) in order to make the bias circuit stable. The appropriate value, R_b , depends on the microphone 's characteristics.

The output is placed in a Hi-Z state in suspend mode.

2.4 EEPROM Interface

The AK4571 has all descriptors, including String Descriptors, in its internal ROM so it does not require an external EEPROM. The AK4571 also has an EEPROM interface so that an external EEPROM can be attached for customizing Vendor ID, Product ID, vendor name and product name.

The EPEN pin should be "L" if the EEPROM is not used. CS, SK, EPAO pins are at a Hi-Z state in this configuration. Please see "Descriptors in Detail" section for internal ROM information.

The EPEN pin should be "H" if an external EEPROM is used. The AK4571 reads the Device Descriptor from the EEPROM after a USB Reset. The AK4571 starts to read String Descriptor just after receiving "GET Descriptor (String)" request.

With the AK4571 you can customize the following fields:

- 1) Device Descriptor (18 bytes)
- 2) String Descriptor (Language ID, Manufacturer Name, Product Name)

Microwire type (4 wire) , 1K/2K/4K bit EEPROM can be used (for example, AK93C45A/55A/65A)

If a 1Kbit EEPROM is selected, the length of Manufacturer name or Product name should be just 50 bytes. As each String Descriptor requires 2-bytes of length information, the total length of each String Descriptor is 52 bytes.

If a 2K/4K bit EEPROM is selected, the length of Manufacturer name or Product name should be just 100 bytes. As each String Descriptor requires 2-bytes of length information, the total length of each String Descriptor is 102 bytes.

If a 1K bit EEPROM is used, EPSEL pin should be "L" while EPSEL pin should be "H" for a 2K/4K EEPROM.

The length in both cases should be exactly 52 bytes or 102 bytes, no longer, no shorter.

Table 1 shows the relationship between EEPROM address and Descriptor.

	1K bit EEPROM (AK93C45A)	2K/4K bit EEPROM (AK93C55A/65A)
Device Descriptor (18 bytes)	00h -08h	00h-08h
String Descriptor Lang ID (4 bytes index = 0)	09h -0Ah	09h-0Ah
String Descriptor iManufacturer (52 or 102 bytes: index =1)	0Bh-24h-	0Bh-3Dh
String Descriptor iProduct (52 or 102 bytes: index = 2)	25h-3Eh	3Eh-71h

Table 1 Relationship between EEPROM Address and Descriptor

Since the AK4571 cannot write data to the EEPROM, the EEPROM should be mounted on the PCB after it has been programmed with the necessary data. Please refer to the AKM EEPROM datasheet for the write sequence. If EEPROM is not used (EPEN = "L"), an EEPROM should not be mounted on the PCB because the CS, CK and EPAO outputs are Hi-Z when EPEN = "L".

2.5 Bass Boost

The AK4571 has an analog bass boost that is activated by mounting a resistor and a capacitor between LBFO-LBFI, and RBFO-RBFI respectively as Figure 6 shows. Bass frequencies can be amplified up to 20dB by selecting an appropriate resistor. Cut-off frequency shifts as the capacitor value varies.

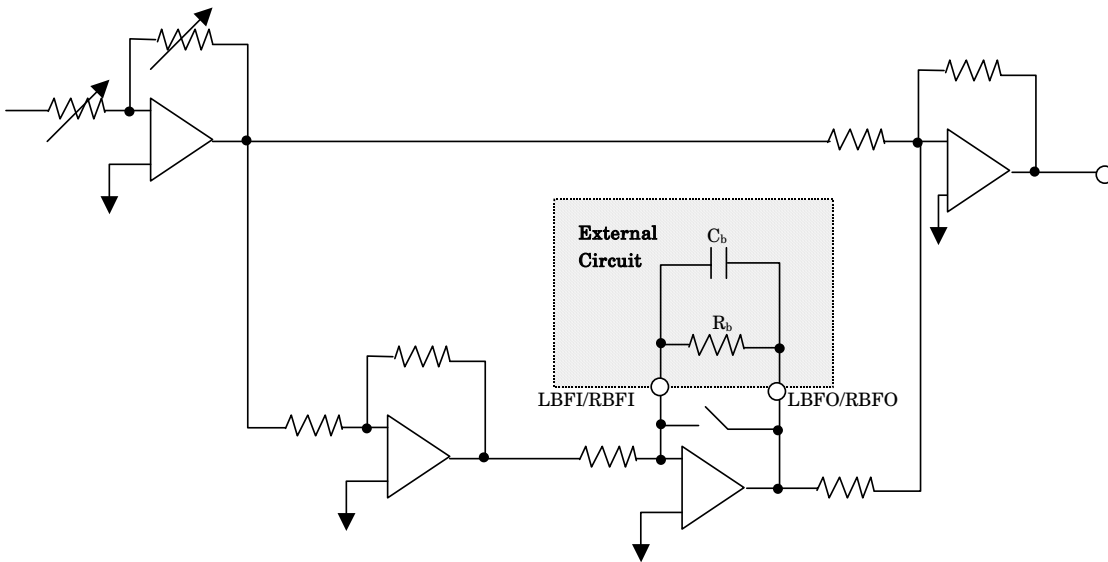

Figure 6 Analog Bass Boost Circuit

Bass Boost

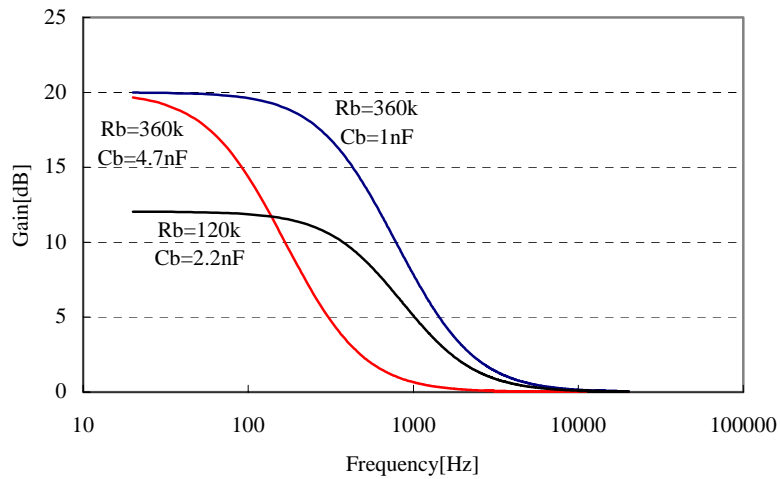

Figure 7 Bass Boost Characteristics

2.6 HID (Human Interface Device)

2.6.1 HID Overview

The AK4571 has two pins for incrementing or decrementing the lineout volume (INC pin and DEC pin), and has a pin for the control of mute (OMUTE pin). For example, the lineout volume slider in a Windows application automatically moves up at the rising edge of INC pin. This means that the value in the Windows program is synchronized with the device's hardware value.

If a button is pressed, the internal bit assigned to it is set to "1". Based on the USB spec for HID, the host knows whether the INC button and/or DEC button and/or OMUTE buttons are pressed or not by periodically issuing an Interrupt transfer request. The AK4571 notifies the host of the status change, but does not change the value itself. The application program changes the value by issuing a SET FEATURE REQUEST.

2.6.2 HID Details

The AK4571 has Interface (#3) and Interrupt Endpoint (#4: 1 byte) commands for HID. Figure 8 shows hierarchy of HID Interface.

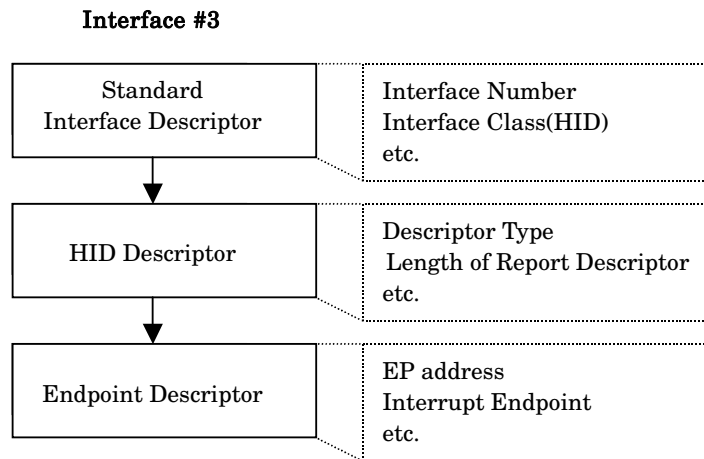

Figure 8 Hierarchy of HID Interface

Interrupt Endpoint is 1 byte, and lower 3 bits are valid.

Bit 7	Bit 6	Bit 5	Bit 4	Bit 3	Bit 2	Bit 1	Bit 0
"0"	"0"	"0"	"0"	"0"	OMUTE	DEC	INC

Internal bits[2:0] are set to "1" at the rising edge of OMUTE, INC or DEC pins, and are cleared to "0" at the falling edge of these respective pins. The AK4571 transmits 1 byte of data through the Interrupt Pipe. If none of the buttons are pressed or if a button is continually pressed, the AK4571 sends NAK to the host.

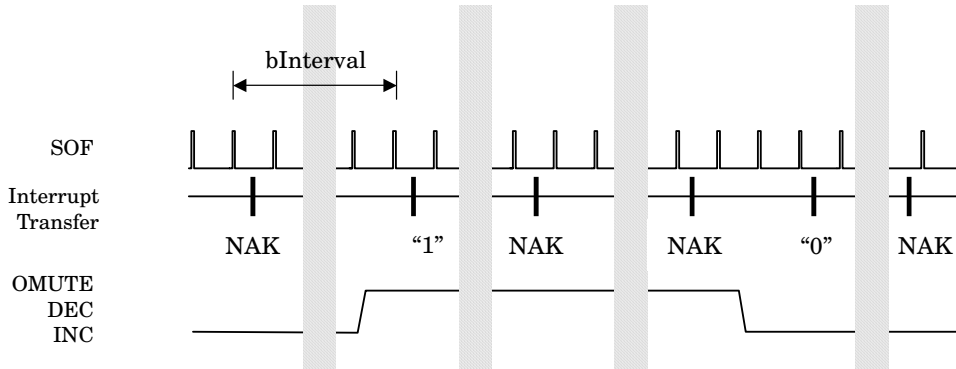

Figure 9 Interrupt Transfer Timing

illustrates a switch de-bounce circuit (highly recommended)

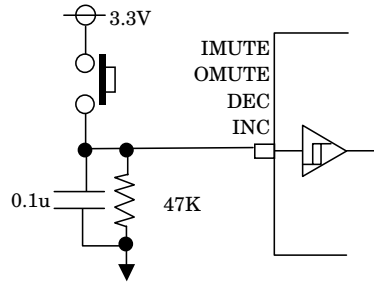

Figure 10 Switch De-Bounce Circuit

Figure 10 illustrates a switch de-bounce circuit (highly recommended)

If HID function is not used, please connect OMUTE pin, DEC pin, INC pin, to DGND.

2.6.3 IMUTE pin and MSTAT pin

The AK4571 has an IMUTE pin for mute control of the recording path. Mute status toggles on the rising edge of the IMUTE pin. Note that pressing a physical button connected to IMUTE changes the internal state. This may cause an inconsistent mute state between the device and the Windows application. MSTAT pin reflects the actual mute status of the device. This limitation comes from the fact that the Windows OS does not support HID audio for recording. The MSTAT pin is forced to “L” in suspend mode regardless of previous state.

MSTAT = (Internal IMUTE status) & SUS_N;
 Normal Operation: “H” -> Mute ON
 “L” -> Mute OFF
 Suspend State: “L”

Figure 10 illustrates a switch de-bounce circuit (highly recommended)

If IMUTE pin is not used, please connect it to DGND.

2.7 Audio Format

The AK4571 supports only the 16-bit, 2's compliment audio format, and outputs LSB first.

1) 16bit mono data format on the USB (A/D data)

Sample #	#1		#2		#3		...
	mono		mono		mono		...
	Lower 8 bit	Upper 8 bit	Lower 8bit	Upper 8 bit	Lower 8 bit	Upper 8 bit	...
bit position	0-7	8-15	0-7	8-15	8-15	8-15	...

2) 16bit stereo data format on the USB (D/A data)

Sample #	#1				#2				...
	Left channel data		Right channel data		Left channel data		Right channel data		...
	Lower 8 bit	Upper 8 bit	Lower 8 bit	Upper 8 bit	Lower 8 bit	Upper 8 bit	Lower 8bit	Upper 8 bit	...
bit position	0-7	8-15	0-7	8-15	0-7	8-15	0-7	8-15	...

2.8 Device topology and function

USB audio devices must report their capabilities to the host and must report the topology that describes the connections between blocks. Figure 11 shows the topology of the AK4571.

The host obtains the capabilities and connection diagram from the device by reading the Audio Control (AC) Interface Descriptor. The volume, mute, and sampling rate are controlled via Audio Class Specific Requests.

- 1) IN Endpoint#1 for A/D data is related to the MIC signal that is described as [OT1]. The MIC signal is amplified via FU1 and is digitized by the A/D converter and transmitted to the host.
- 2) OUT Endpoint#2 for D/A data is related to the Lineout. The D/A analog signal is mixed with the MIC analog signal that is amplified through FU2. The mixed analog signal can be attenuated/boosted by FU3, and is output via Lineout.
- 3) Endpoint#3 for HID is related to playback mute and volume up/down.

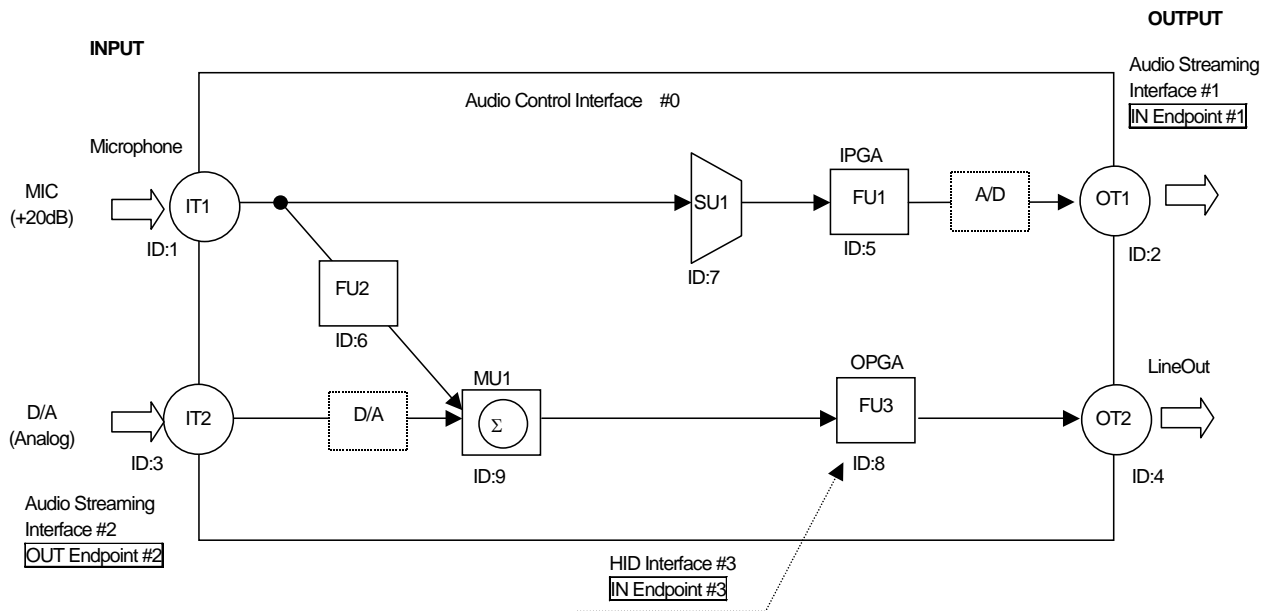

Figure 11 AK4571 Topology

2.8.1 Terminal/Units

- a) Input Terminal (IT)
IT is abbreviation of Input Terminal: IT1 (Microphone Input ID:1), IT2 (D/A Input ID:3)
- b) Output Terminal (OT)
OT is abbreviation of Output Terminal: OT1(A/D Output ID:2), OT2 (Lineout ID:4)
- c) FU (Feature Unit)

The FU (Feature Unit) describes that the AK4571 has volume/mute/bass-boost functions by setting the **bmaControls(0)**, **bmaControls(1)** , **bmaControls(2)** to “1”. The bit position assigned to the bass-boost function is D8, the length of **bcontrolSize** for FU3 is 0x02, and others are 0x01.

bmaControl(0) means master channel. The AK4571 controls DAC mute or bass-boost via the master channel, and controls DAC volume via channel 1 and channel 2 controls. Since the AK4571 input is a single-channel, it controls both ADC mute and volume via the master channel.

- e) MU (Mixer Unit)

The MU (Mixer Unit) describes mixing and volume control functions. Each input channel is connected to all output channels per the USB Audio Class specification shown in Figure 12. Only mixing function is available in the AK4571 because the volume is controlled via Feature Unit. Therefore, bitmap of **bmControl** in Mixer Unit Descriptor is all “0”.

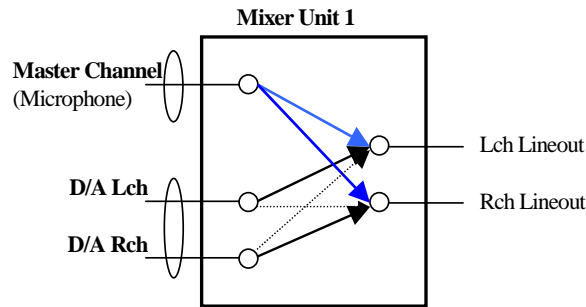

Figure 12 Channel Connection

- f) SU (Selector Unit)

Selector Unit is unnecessary for the AK4571's topology. Windows application does not display playback MIC volume slider if the AK4571 does not define Selector Unit.

2.8.2 Descriptor Overview

When the AK4571 is connected to the USB bus, the host assigns unique address to the device first, and starts reading of the device's information via a default pipe. Descriptors consist of (1) Device Descriptor, (2) Configuration Descriptor, (3) Interface Descriptor, (4) Endpoint Descriptor.

The AK4571 is defined as a device with one configuration and four interfaces. It has one Endpoint (EP) for Interface#0, one EP for Interface#1 (ADC), one for Interface#2 (DAC), and one for Interface#3 (HID)

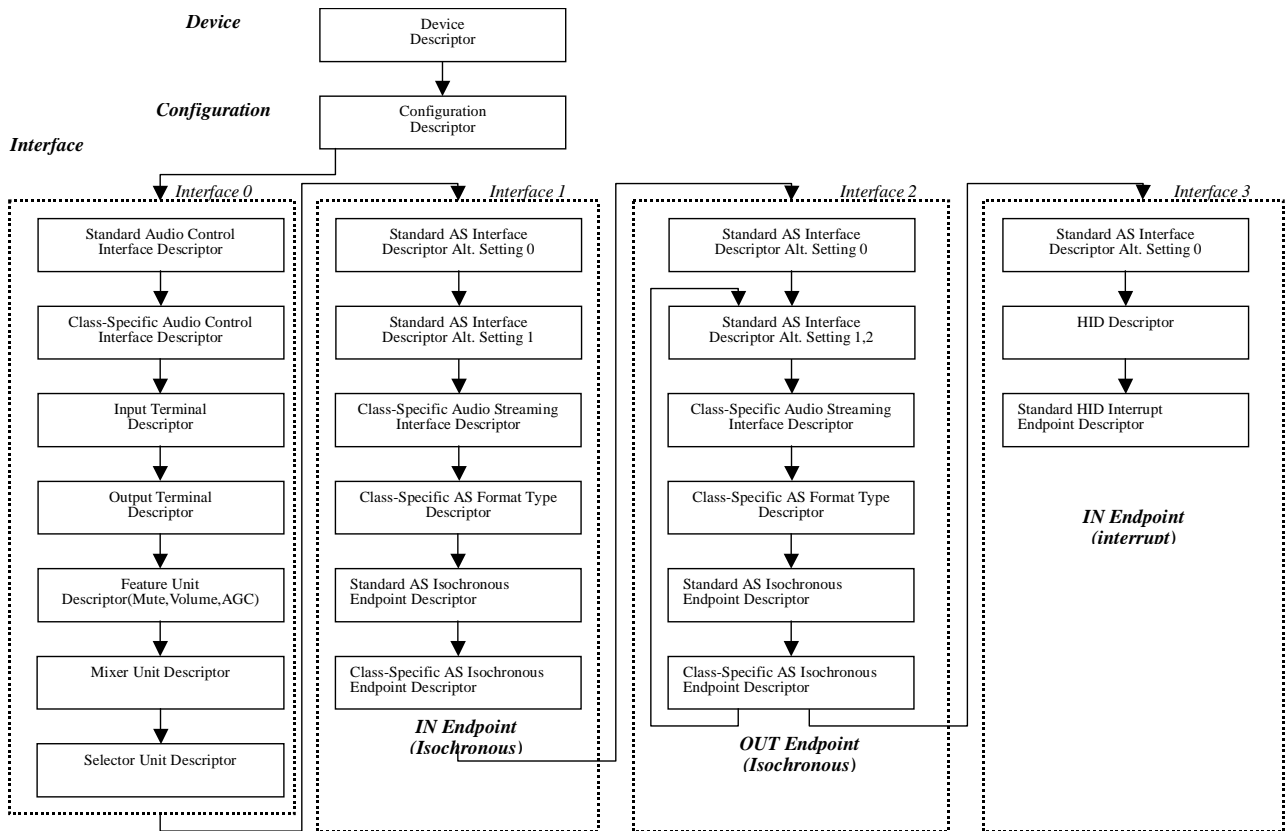

Figure 13 Descriptor Hierarchy

■ Device Descriptor

Device Descriptor includes product name, manufacturer name, product revision, etc. And it also includes the number of configurations (The AK4571 is a one configuration device).

■ Configuration Descriptor

Configuration Descriptor includes the device type, which is described as bus-powered device or self-powered device, power consumption, number of interfaces, etc. The AK4571 is defined as a low-power bus-powered device with four interfaces.

■ Interface Descriptor

The AK4571 has four interfaces as follows.

- a) Audio Control (AC) Interface
- b) Audio Streaming (AS) Interface1 for A/D converter
- c) Audio Streaming (AS) Interface2 for D/A converter
- d) HID Interface for Mute & Volume Control

AC Interface includes topology information, Input/Output Terminal information, and Function information in addition to the standard Class Interface Descriptor.

AS Interface also includes audio format and sampling frequencies.

The AK4571 has two alternates for Interface#1 (ADC), and Interface#2 (DAC). The default state is Alt0, and Alt 0 does not occupy USB bandwidth.

Alt 1 is used as the interface for audio streaming data. The bandwidth occupied by A/D data and D/A data are 100 bytes and 200 bytes respectively, and each value is described in the **wMaxPacketSize** field in the Standard Endpoint Descriptor in each interface.

■ Endpoint Descriptor

Endpoint 0 (EP0: default pipe) is used for AC Interface. The EP for the AS interface includes IN/OUT, synchronization type, maximum packet length, etc.

The AK4571 also has one Interrupt Endpoint for the HID Interface. The AK4571 returns one byte of information at the Interrupt transfer just after the playback volume or mute buttons are pressed. If no buttons are pressed, the AK4571 returns NAK.

3 Descriptors in Detail

3.1 Device Descriptor

Offset	Field	Size	Value	Description
0	bLength	1	0x12	Size of this descriptor in bytes
1	bDescriptorType	1	0x01	DEVICE descriptor
2	BcdUSB	2	0x0110	1.10 - current revision of USB spec.
4	bDeviceClass	1	0x00	Device defined at Interface level
5	bDeviceSubClass	1	0x00	Unused
6	bDeviceProtocol	1	0x00	Unused
7	bMaxPacketSize0	1	0x08	8 bytes
8	IdVendor	2	0x0556	AKM's Vendor ID
10	IdProduct	2	0x0004	Upper 00 means Audio Product Lower 03 means AKM product ID
12	bcdDevice	2	0x0100	Device release code
14	IManufacturer	1	0x01	“ AKM ”
15	Iproduct	1	0x02	“ AK4571”
16	ISerialNumber	1	0x00	Unused
17	bNumConfigurations	1	0x01	One configuration

Table Device Descriptor

3.2 Configuration Descriptor

Offset	Field	Size	Value	Description
0	Blength	1	0x09	Size of this descriptor
1	bDescriptorType	1	0x02	CONFIGURATION descriptor
2	WTotalLength	2	0x011C	length of entire configuration block total 284 bytes including this interface descriptor.
4	BnumInterfaces	1	0x04	Four interfaces
5	bConfigurationValue	1	0x01	index of this configuration
6	IConfiguration	1	0x00	null string
7	BmAttributes	1	0x80	supports Bus Powered Device
8	MaxPower	1	0x31	98mA

3.3 Interface Descriptor # 0

3.3.1 Standard Audio Control Interface Descriptor

Offset	Field	Size	Value	Description
0	bLength	1	0x09	Size of this descriptor
1	bDescriptorType	1	0x04	INTERFACE descriptor
2	bInterfaceNumber	1	0x00	Index of this interface
3	bAlternateSetting	1	0x00	Index of this setting
4	bNumEndpoints	1	0x00	only uses Endpoint 0
5	bInterfaceClass	1	0x01	AUDIO
6	bInterfaceSubclass	1	0x01	AUDIO_CONTROL
7	bInterfaceProtocol	1	0x00	not vendor or class specific
8	IInterface	1	0x00	null string

Table Standard Interface Descriptor

3.3.2 Class-Specific Audio Control Interface Descriptor

Offset	Field	Size	Value	Description
0	BLength	1	0x0A	Size of this descriptor
1	bDescriptorType	1	0x24	CS_INTERFACE
2	bDescriptorSubtype	1	0x01	HEADER subtype
3	BcdADC	2	0x0100	Revision of class specification – 1.00
5	wTotalLength	2	0x0065	Total size of class-specific Audio Control Interface descriptors 101 bytes (includes this descriptor)
7	binCollection	1	0x02	The number of streaming interfaces
8	baInterfaceNr(0)	1	0x01	Streaming interface number 1 belongs to this audio control interface. IN Interface
9	baInterfaceNr(1)	1	0x02	Streaming interface number 2 belongs to this audio control interface. OUT Interface

3.3.3 Terminal Descriptor(ID=3)

D/A Input Terminal

Offset	Field	Size	Value	Description
0	Blength	1	0x0C	Size of this descriptor
1	BDescriptorType	1	0x24	CS_INTERFACE
2	bDescriptorSubtype	1	0x02	INPUT_TERMINAL subtype
3	BterminalID	1	0x03	ID of this terminal
4	WterminalType	2	0x0101	Terminal is USB streaming OUT
6	BassocTerminal	1	0x04	Associated with Output Terminal is 0x04
7	BnrChannels	1	0x02	Two channel
8	WChannelConfig	2	0x0003	Left/Right Front
10	IchannelNames	1	0x00	Unused
11	Iterminal	1	0x00	Unused

3.3.4 Terminal Descriptor(ID=4)

Lineout Terminal

Offset	Field	Size	Value	Description
0	Blength	1	0x09	Size of this descriptor
1	BdescriptorType	1	0x24	CS_INTERFACE
2	bdescriptorSubtype	1	0x03	OUTPUT_TERMINAL subtype
3	BterminalID	1	0x04	ID of this terminal
4	WterminalType	2	0x0301	Terminal is Speaker
6	BassocTerminal	1	0x03	Associate with Input Terminal 0x03
7	BsourceID	1	0x08	From Feature Unit (ID8)
8	Iterminal	1	0x00	Unused

3.3.5 Terminal Descriptor(ID=1)

Analog Microphone Input Terminal

Offset	Field	Size	Value	Description
0	Blength	1	0x0C	Size of this descriptor
1	bDescriptorType	1	0x24	CS_INTERFACE
2	bDescriptorSubtype	1	0x02	INPUT_TERMINAL subtype
3	BterminalID	1	0x01	ID of this terminal
4	WTerminalType	2	0x0201	Terminal is Microphone
6	BAssocTerminal	1	0x02	Associated with Output Terminal 0x02
7	BNrChannels	1	0x01	One channel
8	WChannelConfig	2	0x0000	Mono sets no position bit
10	IChannelNames	1	0x00	Unused
11	Iterminal	1	0x00	Unused

3.3.6 Terminal Descriptor (ID=2)

A/D Output Terminal

Offset	Field	Size	Value	Description
0	Blength	1	0x09	Size of this descriptor
1	BdescriptorType	1	0x24	CS_INTERFACE
2	bdescriptorSubtype	1	0x03	OUTPUT_TERMINAL subtype
3	BterminalID	1	0x02	ID of this terminal
4	WterminalType	2	0x0101	Terminal is USB streaming
6	BassocTerminal	1	0x01	Associate with Input Terminal is 0x01
7	BsourceID	1	0x05	From Feature Unit (ID5)
8	Iterminal	1	0x00	Unused

3.3.7 Feature Unit Descriptor(ID=5)

Microphone Recording Volume Unit

Offset	Field	Size	Value	Description
0	Blength	1	0x08	Size of this descriptor
1	BdescriptorType	1	0x24	CS_INTERFACE
2	BdescriptorSubtype	1	0x06	FEATURE_UNIT descriptor subtype
3	BunitID	1	0x05	ID of this feature Unit
4	BsourceID	1	0x07	From Selector Unit
5	BcontrolSize	1	0x01	One byte Control Array
6	bmaControls(0)	1	0x03	D0(Mute), D1(Volume) supported
7	Ifeature	1	0x00	Unused

3.3.8 Feature Unit Descriptor(ID=6)

Microphone Playback Volume Unit

Offset	Field	Size	Value	Description
0	Blength	1	0x08	Size of this descriptor
1	BdescriptorType	1	0x24	CS_INTERFACE
2	BdescriptorSubtype	1	0x06	FEATURE_UNIT descriptor subtype
3	BunitID	1	0x06	ID of this feature Unit
4	BsourceID	1	0x01	From Input Terminal (Microphone)
5	BcontrolSize	1	0x01	One byte Control Array
6	bmaControls(0)	1	0x03	D0(Mute) D1(Volume) supported
7	Ifeature	1	0x00	Unused

3.3.9 Feature Unit Descriptor(ID=8)

Lineout Volume/Bass Boost Unit

Offset	Field	Size	Value	Description
0	blength	1	0x0D	Size of this descriptor
1	bdescriptorType	1	0x24	CS_INTERFACE
2	bdescriptorSubtype	1	0x06	FEATURE_UNIT descriptor subtype
3	bunitID	1	0x08	ID of this feature Unit
4	BsourceID	1	0x09	From Mixer Unit(ID9)
5	BcontrolSize	1	0x02	Two byte Control Array
6	bmaControls(0)	1	0x0101	D0(Mute) , D8(Bass Boost)is enable for channel0
8	bmaControls(1)	1	0x0002	D1(Volume) control is enable for channel 1
10	bmaControls(2)	1	0x0002	D1(Volume) control is enable for channel 2
12	IFeature	1	0x00	Unused

3.3.10 Mixer Unit Descriptor(ID=9)

Mixer Unit (D/A and Microphone)

Offset	Field	Size	Value	Description
0	blength	1	0x0D	Size of this descriptor
1	bdescriptorType	1	0x24	CS_INTERFACE
2	bdescriptorSubtype	1	0x04	MIXER_UNIT subtype
3	bunitID	1	0x09	ID of this terminal
4	bnrInPins	1	0x02	Number of Input Pin
5	baSourceID(1)	1	0x06	From Feature Unit 2(ID6)
6	baSourceID(2)	1	0x03	From IT(ID3)
7	bnrChannels	1	0x02	Number of logical output channels in the Mixer's output audio channel cluster
8	wChannnelConfig	2	0x0003	describes the spatial location L/R front
10	iChannelNames	1	0x00	Index of String descriptor
11	bmControl	1	0x00	bit map no control
12	Imixer	1	0x00	Index of String descriptor

3.3.11 Selector Unit Descriptor(ID=7)

Offset	Field	Size	Value	Description
0	blength	1	0x07	Size of this descriptor
1	bdescriptorType	1	0x24	CS_INTERFACE
2	bdescriptorSubtype	1	0x05	Selector_UNIT descriptor subtype
3	bunitID	1	0x07	ID of this feature Unit
4	bNrInPins	1	0x01	Inputs Pins
5	bSourceID(1)	1	0x01	From Input Terminal
6	IFeature	1	0x00	Unused

3.4 Interface Descriptor #1

3.4.1 Standard Interface descriptor <Alternate Setting 0> (A/D Audio Streaming Data)

Zero Bandwidth

Offset	Field	Size	Value	Description
0	bLength	1	0x09	Length of this descriptor
1	bDescriptorType	1	0x04	INTERFACE descriptor
2	bInterfaceNumber	1	0x01	Index of this interface
3	bAlternateSetting	1	0x00	Index of this setting
4	bNumEndpoints	1	0x00	0 Endpoint
5	bInterfaceClass	1	0x01	AUDIO
6	bInterfaceSubclass	1	0x02	AUDIO_STREAMING
7	bInterfaceProtocol	1	0x00	Unused
8	iInterface	1	0x00	null string

3.4.2 Standard Interface descriptor <Alternate Setting 1> (A/D Audio Streaming Data)

Offset	Field	Size	Value	Description
0	bLength	1	0x09	Length of this descriptor
1	bDescriptorType	1	0x04	INTERFACE descriptor
2	bInterfaceNumber	1	0x01	Index of this interface
3	bAlternateSetting	1	0x01	Index of this setting
4	bNumEndpoints	1	0x01	1 Endpoint
5	bInterfaceClass	1	0x01	AUDIO
6	bInterfaceSubclass	1	0x02	AUDIO_STREAMING
7	bInterfaceProtocol	1	0x00	Unused
8	iInterface	1	0x00	null string

3.4.3 Class-specific audio streaming interface descriptor <Alt 1>

Offset	Field	Size	Value	Description
0	bLength	1	0x07	Length of this descriptor
1	bDescriptorType	1	0x24	CS_INTERFACE descriptor
2	bDescriptorSubtype	1	0x01	AS_GENERAL
3	bTerminalLink	1	0x02	Unit ID of terminal(Output Terminal ID)
4	bDelay	1	0x00	Interface delay
5	wFormatTag	2	0x0001	PCM

3.4.4 Type I format type descriptor

Offset	Field	Size	Value	Description
0	bLength	1	0x1D	Size of this descriptor
1	bDescriptorType	1	0x24	CS_INTERFACE
2	bDescriptorSubtype	1	0x02	FORMAT_TYPE
3	bFormatType	1	0x01	FORMAT_TYPE_I
4	bNrChannels	1	0x01	One channel
5	bSubFrameSize	1	0x02	Two bytes per slot
6	bBitResolution	1	0x10	16 bits
7	bSamFreqType	1	0x07	Seven frequencies
8	tSamFreq[0]	3	0x001F40	8000Hz
11	tSamFreq[1]	3	0x002B11	11025Hz
14	tSamFreq[2]	3	0x003E80	16000Hz
17	tSamFreq[3]	3	0x005622	22050Hz
20	tSamFreq[4]	3	0x007D00	32000Hz
23	tSamFreq[5]	3	0x00AC44	44100Hz
26	tSamFreq[6]	3	0x00BB80	48000Hz

3.4.5 Standard Endpoint descriptor

Offset	Field	Size	Value	Description
0	bLength	1	0x09	Length of this descriptor
1	bDescriptorType	1	0x05	ENDPOINT descriptor
2	bendpointAddress	1	0x81	Endpoint 1, IN direction
3	bmAttributes	1	0x05	Isochronous, asynchronous
4	wMaxPacketSize	2	0x0064	2byte*50sample*1ch=100 byte/frame
6	bInterval	1	0x01	One packet every frame (Must be set to 1)
7	bRefresh	1	0x00	Unused
8	bSynchAddress	1	0x00	Unused

3.4.6 Class-specific isochronous audio data endpoint descriptor

Offset	Field	Size	Value	Description
0	bLength	1	0x07	Size of this descriptor
1	bDescriptorType	1	0x25	CS_ENDPOINT
2	bDescriptorSubtype	1	0x01	EP_GENERAL
3	bmAttributes	1	0x01	sample rate control
4	bLockDelayUnits	1	0x00	Unused
5	wLockDelay	2	0x0000	

3.5 Interface Descriptor #2

3.5.1 Standard Audio Streaming Interface descriptor <Alternate Setting 0> (D/A Audio Streaming Data) Zero Bandwidth

Offset	Field	Size	Value	Description
0	bLength	1	0x09	Length of this descriptor
1	bDescriptorType	1	0x04	INTERFACE descriptor
2	bInterfaceNumber	1	0x02	Index of this interface
3	bAlternateSetting	1	0x00	Index of this setting
4	bNumEndpoints	1	0x00	endpoints 0
5	bInterfaceClass	1	0x01	AUDIO
6	bInterfaceSubclass	1	0x02	AUDIO_STREAMING
7	bInterfaceProtocol	1	0x00	Unused
10	iInterface	1	0x00	null string

3.5.2 Operational Interface descriptor <Alternate Setting 1> (D/A Audio Streaming Data)

Offset	Field	Size	Value	Description
0	BLength	1	0x09	Length of this descriptor
1	bDescriptorType	1	0x04	INTERFACE descriptor
2	bInterfaceNumber	1	0x02	Index of this interface
3	bAlternateSetting	1	0x01	Index of this setting
4	bNumEndpoints	1	0x01	Streaming Endpoint
5	bInterfaceClass	1	0x01	AUDIO
6	bInterfaceSubclass	1	0x02	AUDIO_STREAMING
7	bInterfaceProtocol	1	0x00	Unused
8	iInterface	1	0x00	null string

3.5.3 Class-specific audio streaming interface descriptor<Alternate Setting 1>

Offset	Field	Size	Value	Description
0	bLength	1	0x07	Length of this descriptor
1	bDescriptorType	1	0x24	CS_INTERFACE descriptor
2	bDescriptorSubtype	1	0x01	AS_GENERAL
3	bTerminalLink	1	0x03	Unit ID of Terminal(Input Terminal)
4	bDelay	1	0x00	Interface delay
5	wFormatTag	2	0x0001	PCM

3.5.4 Type I format type descriptor<Alternate Setting 1>

Offset	Field	Size	Value	Description
0	bLength	1	0x1D	Size of this descriptor
1	bDescriptorType	1	0x24	CS_INTERFACE
2	bDescriptorSubtype	1	0x02	FORMAT_TYPE
3	bFormatType	1	0x01	FORMAT_TYPE_I
4	bNrChannels	1	0x02	Two channels
5	bSubFrameSize	1	0x02	Two bytes per slot
6	bBitResolution	1	0x10	16 bits
7	bSamFreqType	1	0x07	Six frequencies
8	tSamFreq[0]	3	0x001F40	8000Hz
11	tSamFreq[1]	3	0x002B11	11025Hz
14	tSamFreq[2]	3	0x003E80	16000Hz
17	tSamFreq[3]	3	0x005622	22050Hz
20	tSamFreq[4]	3	0x007D00	32000Hz
23	tSamFreq[5]	3	0x00AC44	44100Hz
26	tSamFreq[6]	3	0x00BB80	48000Hz

3.5.5 Endpoint descriptor

Offset	Field	Size	Value	Description
0	bLength	1	0x09	Length of this descriptor
1	bDescriptorType	1	0x05	ENDPOINT descriptor
2	bEndpointAddress	1	0x02	Endpoint 2, OUT direction
3	bmAttributes	1	0x09	Adaptive Isochronous
4	wMaxPacketSize	2	0x00C8	2byte*(48+2)sample*2ch=200 byte/frame
6	bInterval	1	0x01	1millisecond (Must be set to 1)
7	bRefresh	1	0x00	Unused
8	bSynchAddress	1	0x00	Unused

3.5.6 Class-specific isochronous audio data endpoint descriptor

Offset	Field	Size	Value	Description
0	bLength	1	0x07	Size of this descriptor
1	bDescriptorType	1	0x25	CS_ENDPOINT
2	bDescriptorSubtype	1	0x01	EP_GENERAL
3	bmAttributes	1	0x01	Sample rate control
4	bLockDelayUnits	1	0x00	Unused
5	wLockDelay	2	0x0000	Unused

3.6 Interface #3 (HID Class)

3.6.1 Standard Interface Descriptor

Offset	Field	Size	Value	Description
0	bLength	1	0x09	Size of this descriptor
1	bDescriptorType	1	0x04	INTERFACE descriptor
2	bInterfaceNumber	1	0x03	Index of this interface
3	bAlternateSetting	1	0x00	Index of this setting
4	bNumEndpoints	1	0x01	endpoint 1
5	bInterfaceClass	1	0x03	HID
6	bInterfaceSubclass	1	0x00	Non-Boot Device
7	bInterfaceProtocol	1	0x00	Unused
8	iInterface	1	0x00	null string

3.6.2 HID Descriptor

Offset	Field	Size	Value	Description
0	bLength	1	0x09	Size of this descriptor
1	bDescriptorType	1	0x21	HID
2	bcdHID	2	0x0110	HID spec rev #1.10
4	bCountryCode	1	0x00	
5	bNumDescriptor	1	0x01	
6	bDescriptorType	1	0x22	Report Descriptor
7	bDescriptorLength	2	0x001f	31 bytes

3.6.3 Endpoint Descriptor

Offset	Field	Size	Value	Description
0	bLength	1	0x07	Length of this descriptor
1	bDescriptorType	1	0x05	ENDPOINT descriptor
2	bendpointAddress	1	0x83	Endpoint 3, IN direction
3	bmAttributes	1	0x03	Interrupt
4	wMaxPacketSize	2	0x0001	
6	wInterval	1	0x40	64ms Interval

3.6.6 iProduct (0x02) Field in Device Descriptor

Offset	Field	Size	Value	Description
0	bLength	1	0x34	Length of this descriptor
1	bDescriptorType	1	0x03	STRING descriptor
2	bString	50	0x0041 0x004B 0x0034 0x0035 0x0037 0x0031 0x0020	“AK4571”

4 Standard Device Requests

4.1 Clear Feature

The AK4571 return ACK without ERROR

Offset	Field	Size	Value	Description
0	bmRequestType	1	0x00 0x02	Device Endpoint
1	bRequest	1	0x01	CLEAR_FEATURE
2	wValue	2	0x0000 0x0001	clear ENDPOINT0 HALT clear REMOTE_WAKEUP
4	wIndex	2	0x0000	
6	wLength	2	0x0000	

4.2 Get Configuration

The AK4571 returns "1".

Offset	Field	Size	Value	Description
0	bmRequestType	1	0x80	
1	bRequest	1	0x08	GET_CONFIGURATION
2	wValue	2	0x0000	
4	wIndex	2	0x0000	
6	wLength	2	0x0001	

4.3 Get Descriptor

The AK4571 returns the descriptor that is specified in wValue field.

Offset	Field	Size	Value	Description
0	bmRequestType	1	0x80	
1	bRequest	1	0x06	GET_DESCRIPTOR
2	wValue	2	0xZZZZ	ZZZZ is assigned by host: High Byte is Desc. type, Low Byte is Index. DEVICE : 0x0100 : (Index is 0 only) CONFIGURATION : 0x0200
4	wIndex	2	0x0000	
6	wLength	2	0xZZZZ	Descriptor Length (ZZZZ is assigned by host)

4.4 Get Interface

The AK4571 returns the current alternate value for the interface that is specified in wIndex field. "0x00" or "0x01" is returned for Interface#1, or Interface#2. Only "0x00" is returned for Interface#0 or Interface#3.

Offset	Field	Size	Value	Description
0	bmRequestType	1	0x81	
1	bRequest	1	0x0A	GET_INTERFACE
2	wValue	2	0x0000	ZERO
4	wIndex	2	0x0000 0x0001 0x0002 0x0003	Audio Control Interface Audio Streaming Interface for A/D Audio Streaming Interface for D/A HID Interface
6	wLength	2	0x0001	AK4571 has both a zero bandwidth Audio Streaming Interface and a normal Audio Streaming Interface.

4.5 Get Status

4.5.1 Get Status

Offset	Field	Size	Value	Description
0	bmRequestType	1	0x80 0x81 0x82	DEVICE INTERFACE ENDPOINT
1	bRequest	1	0x00	GET_STATUS
2	wValue	2	0x0000	ZERO
4	wIndex	2	0x0000 0x0001 0x0002 0x0003 0x0000 0x0081 0x0002 0x0083 0x0084	bmRequestType is "DEVICE" bmRequestType is "INTERFACE " bmRequestType is "INTERFACE " bmRequestType is "INTERFACE " bmRequestType is "ENDPOINT" bmRequestType is "ENDPOINT" *) bmRequestType is "ENDPOINT" *) bmRequestType is "ENDPOINT" *)
6	wLength	2	0x0002	

*)This request is valid after "SET_INTERFACE request (except for Alt0)" for each interface is issued. If the AK4571 receives GET_STATUS request prior to SET_INTERFACE request, it returns STALL. If SET_INTERFACE request with Alt1 is issued, GET_STATUS request is valid even if alternate value is returned to "0".

The AK4571 has the following two bytes.

- Device: 0x0000 (Bus Powered, No-remote wakeup)
- Interface: 0x0000
- Endpoint: 0x0000

4.6 Set Address

The AK4571 stores wValue, and returns ACK. It responds to the requests in which this address is specified after receiving this request.

Offset	Field	Size	Value	Description
0	BmRequestType	1	0x00	Zero
1	BRequest	1	0x05	SET_ADDRESS
2	wValue	2	0xZZZZ	Device Address : ZZZZ is assigned by host
4	wIndex	2	0x0000	Zero
6	wLength	2	0x0000	Zero

4.7 Set Configuration

The AK4571 is set to the configuration state, and returns ACK. As the AK4571 is defined as a single-configuration device, only "0x00" or "0x01" are valid terms.

Offset	Field	Size	Value	Description
0	bmRequestType	1	0x00	Zero
1	bRequest	1	0x09	SET_CONFIGURATION
2	wValue	2	0x0000 0x0001 others	Unconfigured State AK4571 is set to configuration state Unconfigured State
4	wIndex	2	0x0000	Zero
6	wLength	2	0x0000	Zero

4.8 Set Feature

Offset	Field	Size	Value	Description
0	bmRequestType	1	0x00 0x02	Device Endpoint
1	bRequest	1	0x03	SET_FEATURE
2	wValue	2	0x0000 0x0001	ENDPOINT(0) HALT REMOETE_WAKEUP
4	wIndex	2	0x0000	
6	wLength	2	0x0000	

If **wValue** is ENDPOINT(0) HALT, the AK4571 returns STALL. If **wValue** is REMOTE_WAKEUP, the AK4571 returns ACK without additional processing because it does not have a remote wakeup function.

4.9 Set Interface

The AK4571 set alternate value that is specified in **wValue** for the interface that is specified in **wIndex** field. Either Alt0 or Alt1 can be set for Interface#1 or Interface #2. Only Alt0 is valid for Interface#0 or Interface#3.

Offset	Field	Size	Value	Description
0	bmRequestType	1	0x01	ONE D7 0 = Host to device D6..5 0 = Standard request D4..0 1 = Recipient is interface
1	bRequest	1	0x0B	SET_INTERFACE
2	wValue	2	0x0000 or 0x0001	Zero bandwidth Alternate Setting Normal Isochronous Streaming
4	wIndex	2	0x0000 0x0001 0x0002 0x0003	Audio Control Interface Audio Streaming Interface IN Audio Streaming Interface OUT HID Interface
6	wLength	2	0x0000	Zero

4.10 Synch Frame

The AK4571 does not support this request.

5 Device Specific Requests

If the AK4571 receives a request that is not supported, or if it receives an invalid parameter, the AK4571 returns STALL.

5.1 Set Feature Unit Control Request

5.1.1 Mute Control

Mute is controlled via the master channel. Both left channel and right channel of lineout are muted at the same time.

Offset	Field	Size	Value	Description
0	bmRequestType	1	0x21	
1	bRequest	1	0x01	SET_CUR
2	wValue	2	0x0100	MUTE_CONTROL CHANNEL_0
4	wIndex	2	0x0500 0x0600 0x0800	Mute for MIC Recording Volume interface 0 Mute for MIC Playback Volume interface 0 Mute for LineOut Volume interface 0
6	wLength	2	0x0001	The Length of Mute Control Parameter Block

Parameter:

Offset	Field	Size	Value	Description
0	bMute	1	0x01 0x00	TRUE FALSE

If invalid data is set, (i.e the parameter is not one of the above values), the AK4571 returns STALL at data phase, and keeps previous value.

5.1.2 Bass Boost

Offset	Field	Size	Value	Description
0	bmRequestType	1	0x21	
1	bRequest	1	0x01	SET_CUR
2	wValue	2	0x0900	BASS_BOOST CHANNEL_0
4	wIndex	2	0x0800	LineOut BASS BOOST interface 0
6	wLength	2	0x0001	The Length of Mute Control Parameter Block

Parameter:

Offset	Field	Size	Value	Description
0	bBassBoost	1	0x01 0x00	TRUE FALSE

If invalid data is set, (i.e the parameter is not one of the above values), the AK4571 returns STALL at data phase, and keeps previous value.

5.1.3 Volume Control

The ADC volume is controlled via the master channel, and the DAC volume is controlled via channel 1 (Left channel) and channel 2 (Right channel) independently.

Offset	Field	Size	Value	Description
0	bmRequestType	1	0x21	
1	bRequest	1	0x01	SET_CUR
2	wValue	2	0x0200 0x0201 0x0202	A/D: VOLUME_CONTROL Master Channel DAC: VOLUME_CONTROL CHANNEL_1 DAC: VOLUME_CONTROL CHANNEL_2
4	wIndex	2	0x0500 0x0600 0x0800 0x0800	A/D Feature Unit ID: 0x05 (MIC REC Master CH) A/D Feature Unit ID: 0x06 (MIC PLAY Master CH) D/A Feature Unit ID: 0x08 (Lineout Lch Volume) D/A Feature Unit ID: 0x08 (Lineout Rch Volume) Lower Byte: Audio Control Interface (0x00)
6	wLength	2	0x0002	Volume Control

Parameter:

Offset	Field	Size	Value	Description
0	wVolume	2	0xZZZZ	The value is set by host

The data format for volume follows USB's "Device Class Definition for Audio Devices". If the parameter value is larger than the maximum value, the AK4571 defaults to the maximum value. If the parameter is smaller than minimum value, it defaults to the minimum value.

■ Volume for FU1 (ID5: MIC Recording), and FU2 (ID6: MIC Playback)

The AK4571 recognizes the lower byte of the USB Audio Volume format as 00H.

Volume Value	USB Audio Class Format
24.0dB	0x7FFF
-----	-----
24.0dB	0x1800
23.0dB	0x17FF
-----	-----
0.0dB	0x0000
-----	-----
-30.0dB	0xE200
-31.0dB	0xE1FF
-----	-----
-31.0dB	0x8000

■ Volume for FU 3 (ID 8: LineOut)

The AK4571 recognizes the lower byte of the USB Audio Volume format as 00H.

Volume Value	USB Audio Class Format
0.0dB	0x7FFF
-----	-----
0.0dB	0x0000
-1.0dB	0xFF00
-2.0dB	0xFE00
-----	-----
-46.0dB	0xD200
-47.0dB	0xD100
-----	-----
-47.0dB	0x8000

5.2 Set Selector Unit Control Request

5.2.1 Selector Control

Offset	Field	Size	Value	Description
0	bmRequestType	1	0x21	
1	bRequest	1	0x01	SET_CUR
2	wValue	2	0x0000	ZERO
4	wIndex	2	0x0700	SELECTOR UNIT CONTROL Interface 0
6	wLength	2	0x0001	The Length of Mute Control Parameter Block

Parameter:

Offset	Field	Size	Value	Description
0	bSelector	1	0xZZ	The value is set by host

The AK4571 returns ACK, but ignores this value.

5.3 Get Feature Unit Control Request

5.3.1 Mute Control

Offset	Field	Size	Value	Description
0	bmRequestType	1	0xA1	
1	bRequest	1	0x81	GET_CUR
2	wValue	2	0x0100	MUTE_CONTROL CHANNEL_0
4	wIndex	2	0x0500 0x0600 0x0800	Mute for MIC Recording Volume interface 0 Mute for MIC Playback Volume interface 0 Mute for Lineout Volume interface 0 Lower Byte : Audio Control Interface(0x00)
6	wLength	2	0x0001	The Length of Mute Control Parameter Block

The AK4571 returns current value.

Offset	Field	Size	Value	Description
0	bMute	1	0x01 0x00	TRUE FALSE

Default: Mute OFF (0x00): FU1 (ID5), FU3 (ID8)
Mute ON (0x01): FU2 (ID6)

5.3.2 Bass Boost Control

Offset	Field	Size	Value	Description
0	bmRequestType	1	0xA1	
1	bRequest	1	0x81	GET_CUR
2	wValue	2	0x0900	BASS_BOOST CHANNEL_0
4	wIndex	2	0x0800	Feature Unit interface 0
6	wLength	2	0x0001	The Length of Mute Control Parameter Block

The AK4571 returns current value.

Offset	Field	Size	Value	Description
0	bBassBoost	1	0x01 0x00	TRUE FALSE

Default BASS BOOST OFF(0x00):

5.3.3 Volume Control

Offset	Field	Size	Value	Description
0	bmRequestType	1	0xA1	
1	bRequest	1	0x81 0x82 0x83 0x84	GET_CUR GET_MIN GET_MAX GET_RES
2	wValue	2	0x0200 0x0201 0x0202	VOLUME_CONTROL Master CH (FU5, FU6) VOLUME_CONTROL CHANNEL_1 (FU8) VOLUME_CONTROL CHANNEL_2 (FU8)
4	wIndex	2	0x0500 0x0600 0x0800	MIC Recording Volume interface 0 MIC Playback Volume interface 0 Lineout Volume interface 0 Lower Byte: Audio Control Interface(0x00)
6	wLength	2	0x0002	Volume Control

The AK4571 returns the following **wVolume** (two bytes). When it receives a request with other combinations, it returns STALL.

bRequest	wValue	wIndex	wVolume (2 bytes)	Desciptorn
0x81	0x0200	0x0500	0xZZZZ	Returns current MIC volume of recording path.
0x81	0x0200	0x0600	0xZZZZ	Returns current MIC volume of playback path.
0x81	0x0201	0x0800	0xZZZZ	Returns current Left channel volume of Lineout
0x81	0x0202	0x0800	0xZZZZ	Returns current Right channel volume of Lineout
0x82	0x0200	0x0500	0xE100	Returns minimum MIC recording volume (-31dB)
0x82	0x0200	0x0600	0xE100	Returns minimum MIC playback volume (-31dB)
0x82	0x0201	0x0800	0xD100	Returns minimum Lineout volume (-47dB)
0x82	0x0202	0x0800	0xD100	Returns minimum Lineout volume (-47dB)
0x83	0x0200	0x0500	0x1800	Returns maximum MIC recording volume (+24dB)
0x83	0x0200	0x0600	0x1800	Returns maximum MIC playback volume (+24dB)
0x83	0x0201	0x0800	0x0000	Returns maximum Line Out Volume (0dB)
0x83	0x0202	0x0800	0x0000	Returns maximum Line Out Volume (0dB)
0x84	0x0200	0x0500	0x0100	Returns resolution of MIC recording volume (1dB)
0x84	0x0200	0x0600	0x0100	Returns resolution of MIC playback volume (1dB)
0x84	0x0201	0x0800	0x0100	Returns resolution of LineOut Volume (1dB)
0x84	0x0202	0x0800	0x0100	Returns resolution of LineOut Volume (1dB)

Default: 0dB(0x0000)

5.4 Get Selector Unit Control Request

5.4.1 Selector Control

Offset	Field	Size	Value	Description
0	bmRequestType	1	0xa1	
1	bRequest	1	0x81	GET_CUR
2	wValue	2	0x0000	ZERO
4	wIndex	2	0x0700	SELECTOR UNIT CONTROL interface 0
6	wLength	2	0x0001	The Length of Selector Control Parameter Block

Parameter:

Offset	Field	Size	Value	Description
0	bSelector	1	0xZZ	"0x01"

5.5 Get Mixer Unit Control Request

5.5.1 Mixer Control

Offset	Field	Size	Value	Description
0	bmRequestType	1	0xa1	
1	bRequest	1	0x81 0x82 0x83 0x84	GET_CUR GET_MIN GET_MAX GET_RES
2	wValue	2	0x0000	ZERO
4	wIndex	2	0x0900	MIXER UNIT interface 0
6	wLength	2	0x000C	The Length of Mixer Control Parameter Block

Parameter:

Offset	Field	Size	Value	Description
0	bMixer	12	0xZZ	

The AK4571 returns 6 words of "0x0100" for GET_RES request, and returns the following 6 words for GET_CUR, GET_MIN, and GET_MAX requests.

Offset	Value	Description
0	0x0000	Mic 1ch ---- LineOut Lch: 0dB
2	0x0000	Mic 1ch ---- Lineout Rch: 0dB
4	0x0000	DAC Lch ---- Lineout Lch: 0dB
6	0x8000	DAC Lch ---- Lineout Rch: -127dB
8	0x8000	DAC Rch ---- Lineout Lch: -127dB
10	0x0000	DAC Rch ---- Lineout Rch: 0dB

5.6 Endpoint Control Request

The ADC and DAC can independently operate at seven sampling frequencies. The sampling rate is set by a Set Endpoint Control Request. The AK4571 supports SET_CUR/GET_CUR for the **bRequest** field, but does not support GET_MIN, GET_MAX, or GET_RES for the **bRequest** field.

5.6.1 Set Endpoint Control Request

Offset	Field	Size	Value	Description
0	bmRequestType	1	0x22	
1	bRequest	1	0x01	SET_CUR
2	wValue	2	0x0100	Upper byte: SAMPLING_FREQ_CONTROL (0x01) Lower byte : zero
4	wIndex	2	0x0081 0x0002	Endpoint Address (0x81: A/D) Endpoint Address (0x02: D/A)
6	wLength	2	0x0003	The Length of Sampling Frequency Parameter Block

Parameter:

Offset	Field	Size	Value	Description
0	iSampleFreq	3	0xYYYYYY	The following seven values are valid. Others are invalid. 0x001F40 : 8kHz 0x002B11 : 11.025kHz 0x003E80 : 16kHz 0x005622 : 22.05kHz 0x007D00 : 32kHz 0x00AC44 : 44.1kHz 0x00BB80 : 48kHz

The sampling rates of the ADC and DAC can be set independently. If the value entered is not one of the valid settings, the AK4571 ignores the entered value without returning STALL and keeps the previously entered value.

5.6.2 Get Endpoint Control Request for IN endpoint

Offset	Field	Size	Value	Description
0	bmRequestType	1	0xA2	
1	bRequest	1	0x81	GET_CUR
2	wValue	2	0x0100	Upper byte: SAMPLING_FREQ_CONTROL (0x01) Lower byte : zero
4	wIndex	2	0x0081 0x0002	Endpoint Address (0x81: A/D) Endpoint Address (0x02: D/A)
6	wLength	2	0x0003	The Length of Sampling Frequency Parameter Block

Parameter:

Offset	Field	Size	Value	Description
0	iSampleFreq	3	0xYYYYYY	The following seven values are valid. Others are invalid. 0x001F40 : 8kHz 0x002B11 : 11.025kHz 0x003E80 : 16kHz 0x005622 : 22.05kHz 0x007D00 : 32kHz 0x00AC44 : 44.1kHz (default of this LSI) 0x00BB80 : 48kHz

5.7 HID Related Request

5.7.1 Get Descriptor (HID/Report)

Offset	Field	Size	Value	Description
0	BmRequestType	1	0x81	
1	BRequest	1	0x06	GET_DESCRIPTOR
2	wValue	2	0x2100 0x2200	HID Descriptor Report Descriptor
4	wIndex	2	0x0003	Interface Number (#3)
6	wLength	2	0xZZZZ	Descriptor Length (ZZZZ is assigned by host)

The AK4571 returns a HID Descriptor if **wValue** is 0x2100. The AK4571 returns the following 31 bytes if **wValue** is 0x2200.

Report Descriptor		
Usage Page (Consumer)	0x05, 0x0c	
Usage (Consumer Control)	0x09, 0x01	
Collection (Application)	0xA1, 0x01	
Logical Minimum (0)	0x15, 0x00	
Logical Maximum (1)	0x25, 0x01	
Usage (Volume Increment)	0x09, 0xE9	
Usage (Volume Decrement)	0x09, 0xEA	
Report Size (1)	0x75, 0x01	Data Length (1 bit)
Report Count (2)	0x95, 0x02	Number of Data (INC, DEC)
Input (Data, Variable, Absolute, No_Wrap, No_Preferred)	0x81, 0x2A	
Usage (Mute)	0x09, 0xE2	
Report Count (1)	0x95, 0x01	
Input (Data, Variable, Relative, No_Wrap, No_Preferred)	0x81, 0x2E	
Report Count (5)	0x95, 0x05	
Input (Constant)	0x81, 0x01	
End Collection	0xC0	

5.7.2 Get Report Request

Offset	Field	Size	Value	Description
0	bmRequestType	1	0xA1	Class Specific Request
1	BRequest	1	0x01	GET_REPORT
2	Wvalue	2	0x0100	Report Type (IN) and Report ID
4	Windex	2	0x0003	Interface No (#3)
6	WLength	2	0xZZZZ	Report Descriptor Length

The AK4571 transmits one byte data that is the same format as Interrupt transaction. If it receives a request, it sends the internal register value that reflects the button-press state of OMUTE, INC and DEC pins. Note that the AK4571 does not clear the register after it receives this request. (It clears the register only on an Interrupt transfer)

5.8 String Related Request

Offset	Field	Size	Value	Description
0	BmRequestType	1	0x80	
1	BRequest	1	0x06	GET_DESCRIPTOR (String)
2	wValue	2	0x03??	0x03?? is assigned by host: 0x0300: LangID 0x0301: iManufacturer 0x0302: iProduct
4	wIndex	2	don't care	
6	wLength	2	0xZZZZ	Descriptor Length (ZZZZ is assigned by host)

The AK4571 returns String Descriptor that is specified in **wValue**.

6 System Block Diagram

Figure 14 shows the system block diagram when a 1Kbit EEPROM is used.

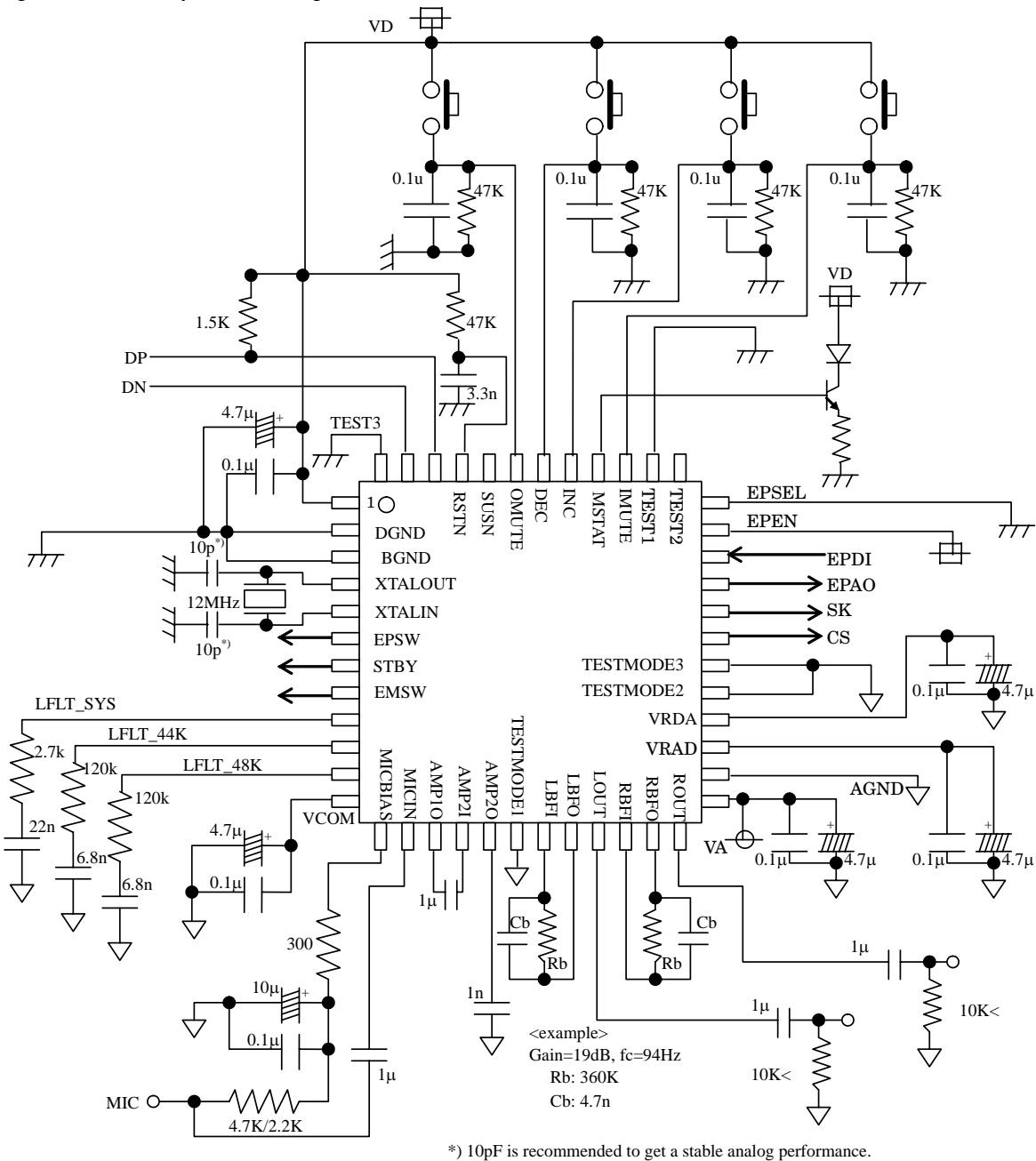
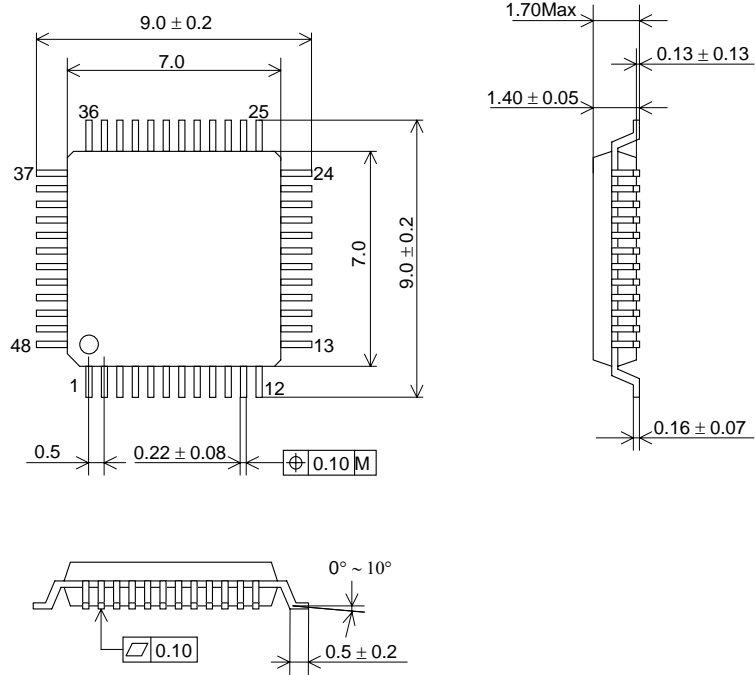

Figure 14 System Block Diagram

7 Package

48pin LQFP(Unit:mm)



8 Marking

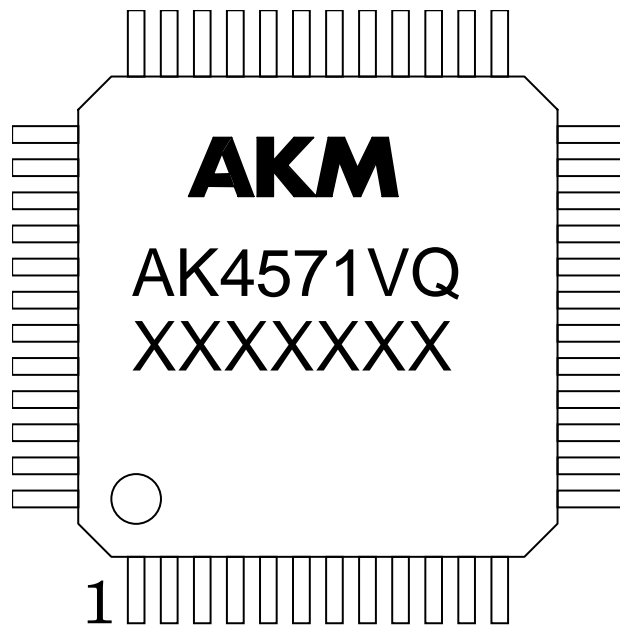

- 1) Pin #1 indication
- 2) Date Code: XXXXXXXX (7 digits)
- 3) Marking Code: AK4571VQ
- 4) Asahi Kasei Logo

IMPORTANT NOTICE

- These products and their specifications are subject to change without notice. Before considering any use or application, consult the Asahi Kasei Microsystems Co., Ltd. (AKM) sales office or authorized distributor concerning their current status.
- AKM assumes no liability for infringement of any patent, intellectual property, or other right in the application or use of any information contained herein.
- Any export of these products, or devices or systems containing them, may require an export license or other official approval under the law and regulations of the country of export pertaining to customs and tariffs, currency exchange, or strategic materials.
- AKM products are neither intended nor authorized for use as critical components in any safety, life support, or other hazard related device or system, and AKM assumes no responsibility relating to any such use, except with the express written consent of the Representative Director of AKM. As used here:
 - (a) A hazard related device or system is one designed or intended for life support or maintenance of safety or for applications in medicine, aerospace, nuclear energy, or other fields, in which its failure to function or perform may reasonably be expected to result in loss of life or in significant injury or damage to person or property.
 - (b) A critical component is one whose failure to function or perform may reasonably be expected to result, whether directly or indirectly, in the loss of the safety or effectiveness of the device or system containing it, and which must therefore meet very high standards of performance and reliability.
- It is the responsibility of the buyer or distributor of an AKM product who distributes, disposes of, or otherwise places the product with a third party to notify that party in advance of the above content and conditions, and the buyer or distributor agrees to assume any and all responsibility and liability for and hold AKM harmless from any and all claims arising from the use of said product in the absence of such notification.