

AsahiKASEI
ASAHI KASEI EMD

AK7780

24bit 5ch ADC & SRC + Audio DSP

GENERAL DESCRIPTION

The AK7780 is a highly integrated audio processor, including a 28-bit floating point DSP, two 24-bit stereo ADC's and one mono ADC. The stereo ADC's feature high performance, achieving 96dB dynamic range, they include 8:1 input selectors. The ADC supports sampling frequencies from 7.35 kHz to 96 kHz. The AK7780 also includes a stereo sample rate converter (SRC), so it can be used as a master device when it receives digital audio inputs. The DSP includes 168kbits of SRAM for audio delay data that is suitable for creating simulated surround fields. The programmable DSP block is realized with 2560step/fs DSP. It supports sampling frequencies from 7.35kHz to 96 kHz. The AK7780 is used to implement complete sound field control, such as echo, 3D, parametric equalization, and other sound enhancements. It is packaged in a 100-lead LQFP package.

FEATURES

[DSP]

Main

- Word length: 28-bit (Data RAM F24.4 limited range floating point)
- Instruction cycle time: 8.1 ns (2560step/fs fs=48kHz; 1280step/fs fs=96kHz)
- Multiplier: 24 x 16 → 40-bit (Double precision available)
- Divider: 24 / 24 → 24-bit
- ALU: 44-bit arithmetic operation (overflow margin: 4-bits)
F24.4 arithmetic and logic operation
- Shift+Register: Flexible setting
- Program RAM: 2048 x 36-bit
- Coefficient RAM: 2048 x 16-bit
- Data RAM: 2048 x 28-bit (F24.4[sign bit + 23-bit mantissa + 4-bit exponent])
- Offset RAM: 64 x 13-bit
- Internal Delay RAM: 168kbits
(6144 x 28 bit / 2048 x 28 bit + 8192 x 14 bit / 3072 x 28 bit + 6144 x 14 bit
/ 4096 x 28 bit + 4096 x 14 bit) 4 pattern setting
28bit = F24.4 [24 bit sign & mantissa: 4 bit exponent]
14bit = F10.4 [10 bit sign & mantissa: 4 bit exponent]
- Sampling frequency: 7.35kHz ~ 96kHz
- Serial interface port for microcontroller or I²C BUS control
- Master Clock: 2560fs (generated by PLL from 32fs, 64fs, 256fs and 384fs)
- Master/Slave operation
- Serial signal input port (10ch): MSB justified 24-bit / LSB justified 16/20/24-bit and I²S
- Serial signal output port(12ch): MSB justified 24-bit / LSB justified 24,16-bit and I²S
(SDOUT1,SDOUT2 and SDOUT3)

[ADC]

4 channels (2 stereo pairs)

- 24-bit 64X over-sampling delta-sigma (fs = 7.35kHz ~ 96kHz)
- DR, S/N: 96dBA (fs = 48kHz, fully-differential input)
- S/(N+D): 92dB (fs = 48kHz)
- Digital HPF (fc = 1Hz)

[ADC]**Mono single channel**

- 24-bit 64X over-sampling delta sigma ($f_s = 7.35\text{kHz} \sim 96\text{kHz}$)
- DR, S/N: 95dBA ($f_s = 48\text{kHz}$)
- Includes digital attenuator

[SRC]**Stereo pair**

- Input frequency 7.35kHz ~ 96kHz → Output frequency 44.1kHz ~ 96kHz

[Other]

- Power supply: $+3.3\text{V} \pm 0.3\text{V}$, $+1.7\text{V} \sim +2.0\text{V}$ (typ +1.8V)
- Operating temperature range: $-40^\circ\text{C} \sim 85^\circ\text{C}$
- Package: 100pin LQFP(0.5mm pitch)

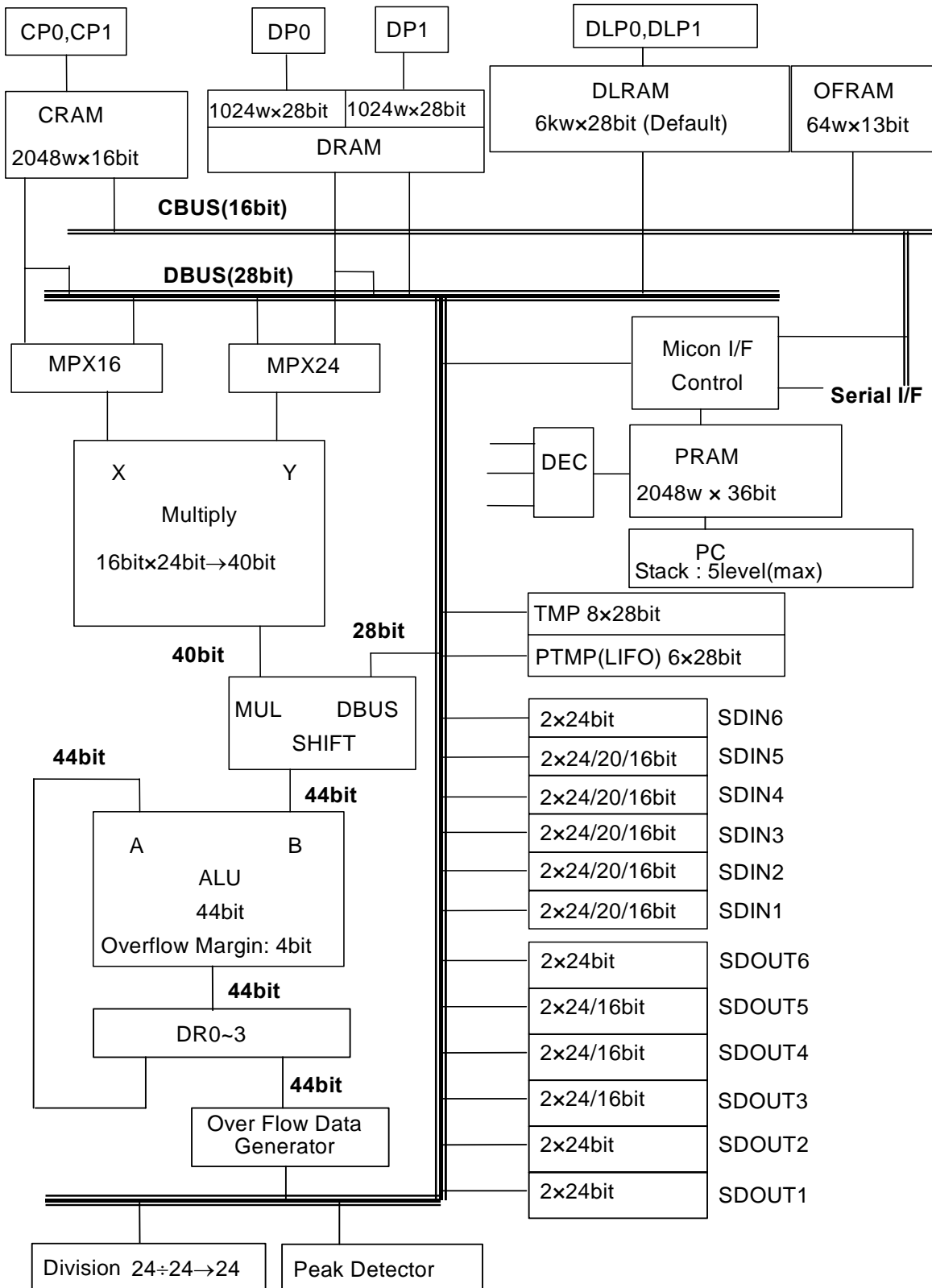

Figure 2. DSP Block Diagram

■ Ordering Guide

AK7780VQ
AKD7780

-40 ~ +85°C 100pin LQFP(0.5mm pitch)
Evaluation Board for AK7780

■ Pin layout

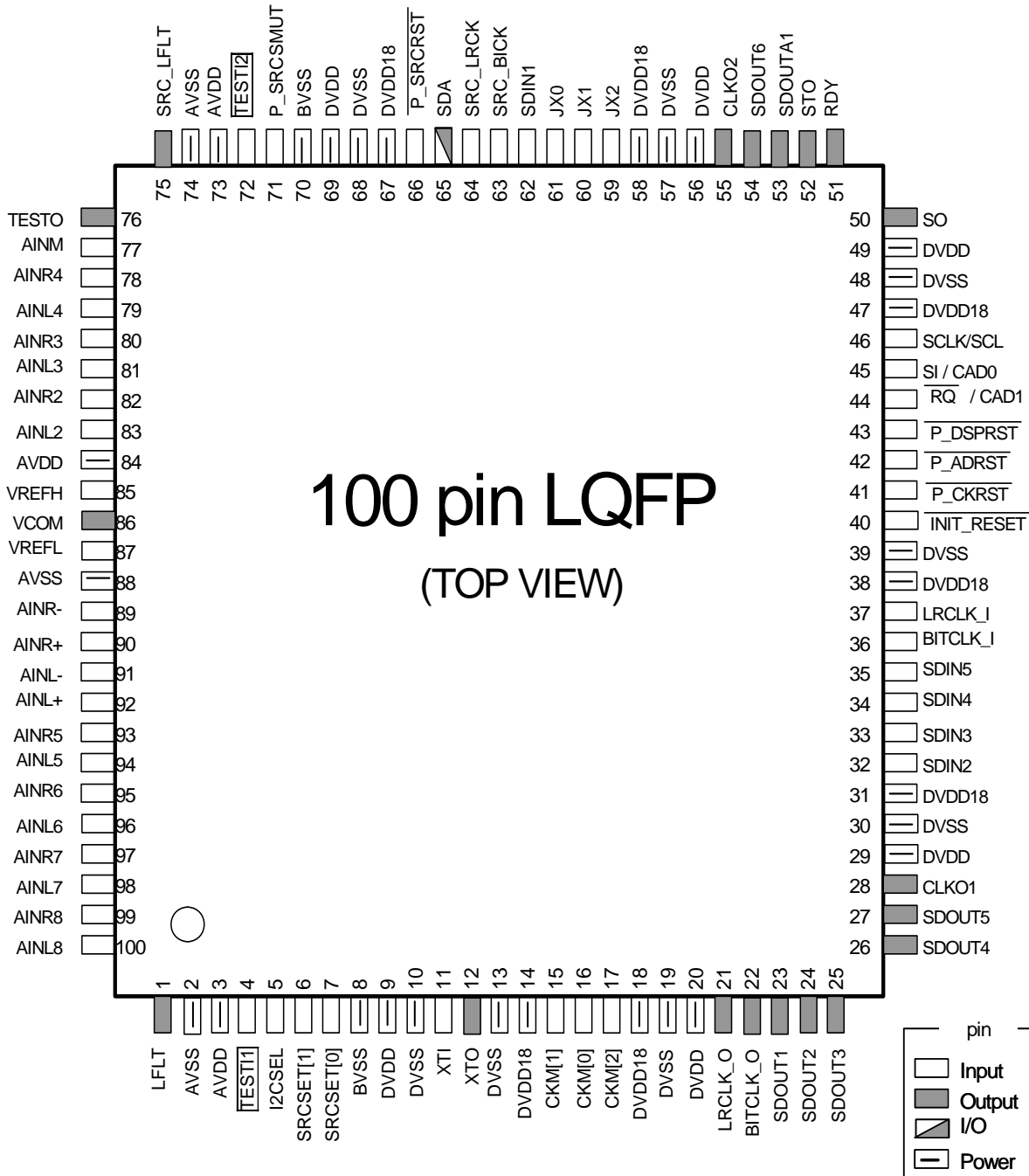

PIN FUNCTION

No	Pin Name	I/O	Function	Classification
1	LFLT	O	Filter connection pin for AK7780 core PLL When using the PLL function, connect with R (1.5kΩ) and C (47nF) in series and connected to analog ground (AVSS) see. 9. System design (1)	Analog Output
2	AVSS	-	Analog ground 0V	Analog Power Supply
3	AVDD	-	Power supply pin for analog section 3.3V (typ)	
4	TEST11	I	TEST pin (Internal pull-down) * Connect to DVSS	TEST
5	I2CSEL	I	I²CBUS select pin * I2CSEL= "L": Normal serial interface * I2CSEL= "H": I ² CBus selected mode. SCL and SDA are active. I2CSEL must be set to "L (DVSS)" or "H (DVDD)".	I ² C Select
6	SRCSET [1]	I	SRC select pin 1	SRC
7	SRCSET [0]	I	SRC select pin 0	
8	BVSS	-	Silicon substrate potential 0V Connect to AVSS.	Analog Power Supply
9	DVDD	-	Power supply pin for digital section 3.3V (typ)	Digital Power Supply
10	DVSS	-	Ground pin for digital section 0V	
11	XTI	I	Master clock input pin Connect a crystal between this pin and the XTO pin, or input an external CMOS clock signal to the XTI pin.	System Clock
12	XTO	O	Crystal oscillator output pin When using a crystal, connect it between XTI and XTO. When using an external clock, keep this pin open.	
13	DVSS	-	Ground pin for digital section 0V	Digital Power Supply
14	DVDD18	-	Power supply pin for digital section 1.8V (typ)	
15	CKM [1]	I	Clock mode select pin 1	Mode select
16	CKM [0]	I	Clock mode select pin 0	
17	CKM [2]	I	Clock mode select pin 2	
18	DVDD18	-	Power supply pin for digital section 1.8V (typ)	Digital Power Supply
19	DVSS	-	Ground pin for digital section 0V	
20	DVDD	-	Power supply pin for digital section 3.3V (typ)	

No	Pin Name	I/O	Function	Classification
21	LRCLK_O	O	LR channel select clock output pin Master mode: Outputs fs clock. Slave mode: Outputs LRCLK_I clock.	System Clock
22	BITCLK_O	O	Serial bit clock output pin Master mode: Outputs 64fs clock. Slave mode: Outputs BITCLK_I clock	
23	SDOUT1	O	DSP Serial data output pin * Compatible with MSB justified 24 bits / I ² S.	Digital section Serial output data
24	SDOUT2	O	DSP Serial data output pin * Compatible with MSB justified 24 bits / I ² S.	
25	SDOUT3	O	DSP Serial data output pin * Compatible with MSB justified 24 bits / LSB justified 24 and 16 bits/ I ² S.	
26	SDOUT4	O	DSP Serial data output pin * Compatible with MSB justified 24 bits / LSB justified 24 and 16 bits/ I ² S.	
27	SDOUT5	O	DSP Serial data output pin * Compatible with MSB justified 24 bits / LSB justified 24 and 16 bits/ I ² S.	
28	CLKO1	O	Clock output pin 1 Select the output frequency through a control register.	Clock output
29	DVDD	-	Power supply pin for digital section 3.3V(typ)	Digital Power Supply
30	DVSS	-	Ground pin for digital section 0.0V	
31	DVDD18	-	Power supply pin for digital section 1.8V(typ)	
32	SDIN2	I	DSP serial data input pin Compatible with MSB justified 24 bits / LSB justified 24, 20 and 16 bits / I ² S. * If not used, connect to DVSS	Digital section Serial input data
33	SDIN3	I	DSP serial data input pin Compatible with MSB justified 24 bits / LSB justified 24, 20 and 16 bits / I ² S. * If not used, connect to DVSS	
34	SDIN4	I	DSP serial data input pin Compatible with MSB justified 24 bits / LSB justified 24, 20 and 16 bits / I ² S. * If not used, connect to DVSS	
35	SDIN5	I	DSP serial data input pin Compatible with MSB justified 24 bits / LSB justified 24, 20 and 16 bits / I ² S. * If not used, connect to DVSS	

No	Pin Name	I/O	Function	Classification
36	BITCLK_I	I	Serial bit clock input pin	System Clock
37	LRCLK_I	I	LR channel select clock input pin.	
38	DVDD18	-	Power supply pin for digital section 1.8V(typ)	Digital power supply
39	DVSS	-	Ground pin for digital section 0.0V	
40	$\overline{\text{INIT_RESET}}$	I	Reset pin (for initialization) Use for initialization. When changing CKM[2:0], XTI or BITCLK_I input frequency, this reset pin must be used.	Reset
41	$\overline{\text{P_CKRST}}$	I	Clock reset pin When changing CKM[2:0] and XTI or BITCLK_I input frequency without using INIT_RESET, pin control is necessary. The control register R_CKRST_N can also rest the clock.	
42	$\overline{\text{P_ADRST}}$	I	ADC Reset pin The control register R_ADRST_N can also reset the ADC. $\overline{\text{P_ADRST}} = \text{“L”}$ and $\overline{\text{P_DSPRST}} = \text{“L”}$ state causes a system reset (S_RESET).	
43	$\overline{\text{P_DSPRST}}$	I	DSP Reset pin The control register R_DSPRST_N can also rest the DSP. $\overline{\text{P_ADRST}} = \text{“L”}$ and $\overline{\text{P_DSPRST}} = \text{“L”}$ state causes a system reset (S_RESET).	
44	$\overline{\text{RQ}}$	I	I2CSEL= “L” Microcomputer interface write request pin. After initial reset, if the microcomputer interface is not used, $\overline{\text{RQ}} = \text{“H”}$	Microcomputer Interface.
	CAD1	I	I2CSEL=“H” I²C Bus address setting pin 1	I ² C
45	SI	I	Microcomputer interface serial data input and serial data output control pin. When SI is not used, leave SI = “L”.	Microcomputer Interface.
	CAD0	I	I2CSEL= “H” I²C Bus address pin 0	I ² C
46	SCLK	I	I2CSEL= “L” Microcomputer interface serial data clock pin. When SCLK is not used, leave SCLK= “H”	Microcomputer Interface.
	SCL	I	I2CSEL= “H” I²C bus data clock pin	I ² C
47	DVDD18	-	Power supply pin for digital section 1.8V(typ)	Digital power supply
48	DVSS	-	Ground pin for digital section 0.0V	
49	DVDD	-	Power supply pin for digital section 3.3V(typ)	
50	SO	O	Serial data output pin for microcomputer interfaces. When $\overline{\text{RQ}} = \text{“H”}$, SO = Hi-Z	Microcomputer Interface.

No	Pin Name	I/O	Function	Classification
51	RDY	O	Data write ready output pin for microcomputer interface.	Microcomputer Interface.
52	STO	O	Status output pin Normal state output "H". When WDT, CRC error or SRC UNLOCK occurs, then output "L". See 3.(1) Whole block diagram.	Status
53	SDOUTA1	O	DSP or ADC Serial data output pin * Compatible with MSB justified 24 bits / I ² S.	Digital section
54	SDOUT6	O	DSP or ADC Serial data output pin * Compatible with MSB justified 24 bits / I ² S.	Serial output data
55	CLKO2	O	Clock output pin 2 Select the output frequency through a control register.	Clock output
56	DVDD	-	Power supply pin for digital section 3.3V(typ)	Digital power supply
57	DVSS	-	Ground pin for digital section 0.0V	
58	DVDD18	-	Power supply pin for digital section 1.8V(typ)	
59	JX2	I	External condition jump pin * When not used, connect to DVSS	Conditional input
60	JX1	I	External condition jump pin * When not used, connect to DVSS	
61	JX0	I	External condition jump pin * When not used, connect to DVSS	
62	SDIN1	I	DSP/SRC Serial input pin Input pin for SRC. When not used, connect to DVSS.	Digital section Serial input data
63	SRC_BICK	I	SRC Serial bit clock input pin.	SRC
64	SRC_LRCK	I	SRC LR channel select clock input pin.	
65	SDA	I	I²CSEL= "L" SDA Outputs "L" level.	I ² C
		I/O	I²CSEL= "H" I²C bus interface data pin	
66	P_SRCRST	I	SRC Reset pin The control register R_SRCRST_N can also rest the SRC.	RESET
67	DVDD18	-	Power supply pin for digital section 1.8V(typ)	Digital power supply
68	DVSS	-	Ground pin for digital section 0.0V	
69	DVDD	-	Power supply pin for digital section 3.3V(typ)	
70	BVSS	-	Silicon substrate potential 0V Connect to AVSS.	Analog power supply
71	P_SRC SMUTE	I	SRC Soft mute pin The control register R_SRCSMUTE can also execute a soft mute on the SRC.	SRC
72	TESTI2	I	TEST pin (Internal pull-down) * Connect to DVSS.	TEST
73	AVDD	-	Power supply pin for analog section 3.3V (typ)	Analog power supply
74	AVSS	-	Analog ground 0V	
75	SRC_LFLT	O	RC Filter connection pin for SRC. See p.86 10-2-5-2: SRC PLL loop filter setting.	Analog output

No	Pin Name	I/O	Function	Classification
76	TESTO	O	TEST OUT pin Hi-Z Output pin. Leave it open.	TEST
77	AINM	I	ADCM single ended analog input	Analog input
78	AINR4	I	ADC1 or ADC2 Rch single ended analog input 4	
79	AINL4	I	ADC1 or ADC2 Lch single ended analog input 4	
80	AINR3	I	ADC1 or ADC2 Rch single ended analog input 3	
81	AINL3	I	ADC1 or ADC2 Lch single ended analog input 3	
82	AINR2	I	ADC1 or ADC2 Rch single ended analog input 2	
83	AINL2	I	ADC1 or ADC2 Lch single ended analog input 2	
84	AVDD	-	Power supply pin for analog section 3.3V (typ)	Analog Power Supply
85	VREFH	I	Analog reference voltage input pin. Connect to AVDD, and connect 0.1 μ F and 10 μ F bypass capacitors between this pin and AVSS.	Analog input
86	VCOM	O	Common voltage Connect to 0.1 μ F and 10 μ F capacitors between this pin and AVSS. Do not connect to external circuitry.	Analog output
87	VREFL	I	Analog reference voltage input pin for low-level. Connect to AVSS.	Analog input
88	AVSS	-	Analog ground 0V	Analog Power Supply
89	AINR-	I	ADC1 or ADC2 Rch inverted input pin	Analog input
90	AINR+	I	ADC1 or ADC2 Rch non- inverted input pin	
91	AINL-	I	ADC1 or ADC2 Lch inverted input pin	
92	AINL+	I	ADC1 or ADC2 Lch non- inverted input pin	
93	AINR5	I	ADC1 or ADC2 Rch single ended analog input 5	
94	AINL5	I	ADC1 or ADC2 Lch single ended analog input 5	
95	AINR6	I	ADC1 or ADC2 Rch single ended analog input 6	
96	AINL6	I	ADC1 or ADC2 Lch single ended analog input 6	
97	AINR7	I	ADC1 or ADC2 Rch single ended analog input 7	
98	AINL7	I	ADC1 or ADC2 Lch single ended analog input 7	
99	AINR8	I	ADC1 or ADC2 Rch single ended analog input 8	
100	AINL8	I	ADC1 or ADC2 Lch single ended analog input 8	

Note 1. Digital input pins must not be allowed to float

Note 2. If analog input pins (AINR-, AINR+, AINL-, AINL+, AINL2-8, AINR2-8, AINM) are not used, leave them open.

Note 3. I2CSEL should be set to "L" (DVSS) or "H" (DVDD).

Relationship with I2CSEL and SDA.

	I2CSEL	$\overline{\text{INIT_RESET}}$	SDA
Normal Microcontroller Interface	L	L	L
	L	H	L
I ² C bus compatible	H	L	"Hi-Z" \rightarrow pull-up function
	H	H	function

ABSOLUTE MAXIMUM RATINGS

(AVSS = BVSS = DVSS = 0V: All indicated voltages are with respect to ground.)

Item	Symbol	min	max	Unit
Power supply voltage				
Analog(AVDD)	VA	-0.3	4.3	V
Digital(DVDD)	VD	-0.3	4.3	V
Digital(DVDD18)	VD18	-0.3	2.5	V
AVSS(BVSS) – DVSS (Note 4)	Δ GND		0.3	V
Input current (except for power supply pin)	IIN	-	\pm 10	mA
Analog input voltage				
AINL+, AINL-, AINR+, AINR-, AINL2-8, AINR2-8, AINM VREFH, VREFL	VINA	-0.3	VA+0.3	V
Digital input voltage	VIND	-0.3	VD+0.3	V
Operating ambient temperature	Ta	-40	85	°C
Storage temperature	Tstg	-65	150	°C

Note 4. AVSS (BVSS) should be at the same level as DVSS.

WARNING: Operation at or beyond these limits may result in permanent damage to the device.
Normal operation is not guaranteed at these critical conditions.

RECOMMENDED OPERATING CONDITIONS

(AVSS = BVSS = DVSS = 0V: All indicated voltages are with respect to ground.)

Items	Symbol	min	typ	max	Unit
Power supply voltage					
AVDD	VA	3.0	3.3	3.6	V
DVDD	VD	3.0	3.3	3.6	V
DVDD18	VD18	1.7	1.8	2.0	V
Reference voltage (VREF)					
VREFH (Note 5)	VRH		VA		V
VREFL (Note 6)	VRL		0.0		V

Note 5. VREFH normally connects to AVDD.

Note 6. VREFL normally connects to AVSS

Note: The analog input voltage and output voltage are proportional to the VREFH-VREFL voltages.

* AKEMD assumes no responsibility for the usage beyond the conditions in this datasheet.

ELECTRIC CHARACTERISTICS

(1) Analog Characteristics

1) ADC Characteristics

(Unless otherwise specified, Ta = 25°C; AVDD = DVDD = 3.3V, DVDD18=1.8V; VREFH = AVDD, VREFL = AVSS; BITCLK = 64 fs; signal frequency = 1kHz; Measurement bandwidth = 20Hz to 20kHz @ 48kHz, 20Hz ~ 40kHz @ 96kHz; ADC specified with differential inputs (ADC1, ADC2); CKM Mode 1(CKM[2:0]= “000”), SRC RESET)

	Parameter	min	typ	max	Unit	
Stereo ADC	Resolution	24			Bits	
	Dynamic characteristics					
	S/(N+D)	fs = 48kHz (-1dBFS) (Note 7)	82	92		dB
		Fs = 96kHz (-1dBFS)		90		dB
	Dynamic range	fs = 48kHz (A filter) (Note 7, Note 8)	88	96		dB
		fs = 96kHz		93		dB
	S/N	fs = 48kHz (A filter) (Note 7)	88	96		dB
		fs = 96kHz		93		dB
	Inter-channel isolation (f=1kHz) (Note 9)	90	115		dB	
	DC accuracy					
	Channel gain mismatch			0.1	0.3	dB
	Analog input					
	Input voltage (Differential input) (Note 10)		±1.85	±2.00	±2.15	Vp-p
Input voltage (Single-ended input) (Note 11)		1.85	2.00	2.15	Vp-p	
Input impedance (Note 12)		22	33		kΩ	
Monaural ADC part	Resolution	24			Bits	
	Dynamic characteristics					
	S/(N+D)	fs = 48kHz (-1dBFS)	78	88		dB
		fs = 96kHz (-1dBFS)		87		dB
	Dynamic range	fs = 48kHz (A filter) (Note 8)	87	95		dB
		fs = 96kHz		92		dB
	S/N	fs = 48kHz (A filter)	87	95		dB
		fs = 96kHz		92		dB
	Analog input					
	Input voltage (Note 13)		1.85	2.00	2.15	Vp-p
Input impedance (Note 14)		22	33		kΩ	

Note 7. This value is not guaranteed for single-ended inputs.

Note 8. Indicates S/(N+D) when -60 dBFS signal is applied.

Note 9. Indicates isolation between L and R when -1dBFS signal is applied.

Note 10. Target input pins are AINL+, AINL-, AINR+ and AINR-.

Differential full scale is $(\pm FS = (VREFH - VREFL) \times (2.0/3.3))$

Note 11. Target input pins are AINL2~L8, AINR2~R8.,

Single-ended full scale is $(FS = (VREFH - VREFL) \times (2.0/3.3))$

Note 12. Target input pins are AINL+, AINL-, AINR+, AINR-, AINL2-L8, AINR2-R8.

Note 13. Target input pin is AINM, The full scale of this pin is $(FS = (VREFH - VREFL) \times (2.0/3.3))$

Note 14. Target input pin is AINM.

2) SRC Characteristics

($T_a=25^\circ\text{C}$; $AVDD = 3.3\text{V}$; $DVDD=3.3\text{V}$; $DVDD18=1.8\text{V}$; data = 24-bits; measurement bandwidth = $20\text{Hz} \sim \text{FSO}/2$; unless otherwise specified.)

Parameter	Symbol	min	typ	max	Units
Resolution				24	Bits
Input Sample Rate	FSI	7.35		96	kHz
Output Sample Rate	FSO	44.1		96	kHz
THD+N (Input= 1kHz, 0dBFS)					
FSO/FSI=44.1kHz/48kHz			-113		dB
FSO/FSI=44.1kHz/96kHz			-112		dB
FSO/FSI=48kHz/44.1kHz			-113		dB
FSO/FSI=48kHz/96kHz			-113		dB
FSO/FSI=48kHz/8kHz			-112	-103	dB
Dynamic Range (Input= 1kHz, -60dBFS)					
FSO/FSI=44.1kHz/48kHz			114		dB
FSO/FSI=44.1kHz/96kHz			114		dB
FSO/FSI=48kHz/44.1kHz			114		dB
FSO/FSI=48kHz/96kHz			114		dB
FSO/FSI=48kHz/8kHz		110	114		dB
Dynamic Range (Input= 1kHz, -60dBFS, A-weighted)					
FSO/FSI=44.1kHz/48kHz			116		dB
Ratio between Input and Output Sample Rate	FSO/FSI	0.45		6	-

(2) DC Characteristics

(Ta = -40°C ~ 85°C; AVDD = DVDD = 3.0~3.6V; DVDD18 = 1.7~2.0V)

Parameter	Symbol	min	typ	max	Unit
High level input voltage (Note 15)	VIH	80%DVDD			V
Low level input voltage (Note 15)	VIL			20%DVDD	V
SCL,SDA High level input voltage	VIH	70%DVDD			V
SCL,SDA Low level input voltage	VIL			30%DVDD	V
High level output voltage Iout=-100μA	VOH	DVDD-0.5			V
Low level output voltage Iout=100μA (Note 16)	VOL			0.5	V
SDA Low level output voltage Iout=3mA	VOL			0.4	V
Input leak current (Note 17)	Iin			±10	μA
Input leak current (pull-down) (Note 18)	Iid		22		μA
Input leak current (XTI pin)	Iix		26		μA

Note 15. SCL (I2CSEL=1) and SDA pins are not included. (SCLK pin is included when I2CSEL=0)

Note 16. SDA pin is not included.

Note 17. The pull-down pins and XTI pin are not included.

Note 18. The pull-down pins (Typ150kΩ) are: TESTI1, TESTI2

(3) Current Consumption

(Ta=25°C; AVDD=DVDD=3.0~3.6V(typ=3.3V,max=3.6V); DVDD18=1.7~2.0V(typ=1.8V, max=2.0V))

Power supply					
Parameter		min	typ	max	Unit
Power supply current (Note 19)					
1) a) AVDD			52	70	mA
b) DVDD			8	15	mA
c) DVDD18			110	165	mA
2) INIT_RESET = "L" (reference) (Note 20)			1		mA

Note 19. Varies slightly according to the system frequency and contents of the DSP program.

Note 20. This is a reference value when using a crystal oscillator.

Since most of the supply current at the initial reset state is in the oscillator section, the value may vary slightly according to the crystal type and the external circuit. This is a "reference value" only.

(4) Digital Filter Characteristics

1) ADC Section: ADC1, ADC2

(Ta=-40°C~85°C; AVDD = DVDD =3.0V~3.6V; DVDD18=1.7V~2.0V; fs=48kHz; [Note 21](#))

Parameter	Symbol	min	typ	max	Unit
Pass band (±0.005dB) (Note 22)	PB	0		21.5	kHz
(-0.02dB)			21.768		kHz
(-6.0dB)			24.00		kHz
Stop band	SB	26.5			kHz
Pass band ripple (Note 22)	PR			±0.005	dB
Stop band attenuation (Note 23 , Note 24)	SA	80			dB
Group delay distortion	ΔGD			0	μs
Group delay (Ts=1/fs)	GD		29		Ts
Digital filter + SFC					
Amplitude characteristics (20Hz~20.0kHz)			±0.01		dB

Note 21. Each parameter is related to the sampling frequency (fs). HPF response is not included.

Note 22. The pass band is from DC to 21.5kHz at fs = 48kHz.

Note 23. The stop band is from 26.5kHz to 3.0455MHz at fs = 48kHz.

Note 24. When fs = 48kHz, the analog modulator samples the analog input at 3.072MHz. The input signal is not attenuated by the digital filter in multiple bands ($n \times 3.072\text{MHz} \pm 21.99\text{kHz}$; n=0, 1, 2, 3...) of the sampling frequency.

2) ADC Section ADCM

(Ta=-40°C~85°C; AVDD = DVDD =3.0V~3.6V; DVDD18=1.7V~2.0V; fs = 48 kHz; [Note 25](#))

Parameter	Symbol	min	typ	max	Unit
Pass band (±0.005dB) (Note 26)	PB	0		21.5	kHz
(-0.02dB)			21.768		kHz
(-6.0dB)			24.00		kHz
Stop band	SB	26.5			kHz
Pass band ripple (Note 26)	PR			±0.005	dB
Stop band attenuation (Note 27 , Note 28)	SA	80			dB
Group delay distortion	ΔGD			0	μs
Group delay (Ts=1/fs) (Note 29)	GD		29		Ts
Digital filter + SFC					
Amplitude characteristics (20Hz~20.0kHz)			±0.1		dB

Note 25. Each parameter is related to the sampling frequency (fs). HPF response is not included.

Note 26. The pass band is from DC to 21.5kHz at fs = 48kHz.

Note 27. The stop band is from 26.5kHz to 3.0455MHz at fs = 48kHz.

Note 28. When fs = 48kHz, the analog modulator samples the analog input at 3.072MHz. The input signal is not attenuated by the digital filter in the multiple bands ($n \times 3.072\text{MHz} \pm 21.99\text{kHz}$; n=0, 1, 2, 3...) of the sampling frequency.

Note 29. VOL+ MUX path adds one additional Ts.

3) SRC

(Ta=-40°C~85°C; AVDD=DVDD=3.0~3.6V; DVDD18 = 1.7~2.0V)

Parameter	Range	Symbol	min	typ	max	Unit
Pass band -0.01dB	$0.980 \leq \text{FSO/FSI} \leq 6.000$	PB	0		0.4583FSI	kHz
	$0.900 \leq \text{FSO/FSI} < 0.990$	PB	0		0.4167FSI	kHz
	$0.533 \leq \text{FSO/FSI} < 0.909$	PB	0		0.2182FSI	kHz
	$0.490 \leq \text{FSO/FSI} < 0.539$	PB	0		0.2177FSI	kHz
	$0.450 \leq \text{FSO/FSI} < 0.495$	PB	0		0.1948FSI	kHz
Stop band	$0.980 \leq \text{FSO/FSI} \leq 6.000$	SB	0.5417FSI			kHz
	$0.900 \leq \text{FSO/FSI} < 0.990$	SB	0.5021FSI			kHz
	$0.533 \leq \text{FSO/FSI} < 0.909$	SB	0.2974FSI			kHz
	$0.490 \leq \text{FSO/FSI} < 0.539$	SB	0.2812FSI			kHz
	$0.450 \leq \text{FSO/FSI} < 0.495$	SB	0.2604FSI			kHz
Pass band ripple		PR			±0.01	dB
Stop band attenuation		SA	95.2			dB
Group delay (Ts=1/fs) (Note 30)		GD		56		Ts

Note 30. Measured from the rising edge of SRC_LRCK on the input to the rising edge of LRCLK_O on the output, with there is no phase difference between input and output.

(5) Switching Characteristics

[#h means hexadecimal code. (#=0, 1, 2, 3, 4, 5, 6, 7, 8, 9, A, B, C, D, E, F)]

1) System Clock

(Ta = -40~85°C; AVDD=DVDD=3.0V~3.6V; DVDD18 = 1.7V~2.0V)

Parameter	Symbol	min	typ	max	Unit
XTI CKM[2:0] 0h,1h,2h,3h					
a) with a crystal oscillator:					
CKM[2:0]=0h,2h	fXTI	-	11.2896 12.288	-	MHz
CKM[2:0]=1h,3h	fXTI	-	16.9344 18.432	-	MHz
b) with an external clock					
Duty cycle		40	50	60	%
CKM[2:0]=0h,2h	fXTI	11.0		12.4	MHz
CKM[2:0]=1h,3h	fXTI	16.5		18.6	MHz
Clock rise time	tCR			6	ns
Clock fall time	tCF			6	ns
LRCLK_I frequency (Note 31)	fs	7.35	48	96	kHz
Clock rise time	tLR			6	ns
Clock fall time	tLF			6	ns
BITCLK_I frequency					
High level width	tBCLKH	64			ns
Low level width	tBCLKL	64			ns
Clock rise time	tBR			6	ns
Clock fall time	tBF			6	ns
a) CKM[2:0]=2h,3h	fBCLK	-	64	-	fs
Duty cycle		40	50	60	%
CKM[2:0]=2h,3h		0.23		6.2	MHz
b) CKM[2:0]=4h,5h (Note 32)	fBCLK	-	64	-	fs
Duty cycle		40	50	60	%
CKM[2:0]=4h	fBCLK	2.75		3.1	MHz
CKM[2:0]=5h	fBCLK	5.5		6.2	MHz

Note 31. LRCLK and sampling rate (fs) should match.

Note 32. When BITCLK_I uses as a resource of master clock, it should be 64 clocks correctly divided within 1fs.

(Ta = -40°C ~85°C; AVDD=DVDD=3.0~3.6V, DVDD18 = 1.7~2.0V)

Parameter	Symbol	min	typ	max	Unit
SRC_LRCK frequency (Note 33)	fs	7.35	48	96	kHz
Clock rise time	tLR			6	ns
Clock fall time	tLF			6	ns
SRC_BICK frequency					
High level width	tBCLKH	60			ns
Low level width	tBCLKL	60			ns
Clock rise time	tBR			6	ns
Clock fall time	tBF			6	ns
	(Note 34) fBCLK	32		128	fs
Duty factor		40	50	60	%
		0.23		6.2	MHz

Note 33. SRC_LRCK and sampling rate (fs) should match.

Note 34. 128fs is up to fs = 48kHz.

2) Reset

(Ta=-40°C ~85°C; AVDD=DVDD=3.0~3.6V; DVDD18 = 1.7~2.0V)

Parameter	Symbol	min	typ	max	Unit
$\overline{\text{INIT_RESET}}$ (Note 35)	tRST	600			ns
$\overline{\text{P_CKRST}}$	tRST	600			ns
$\overline{\text{P_ADRST}}$	tRST	600			ns
$\overline{\text{P_DSPRST}}$	tRST	600			ns
$\overline{\text{P_SRCRST}}$	tRST	600			ns

Note 35. "L" is acceptable when power is turned on, but a stable master clock must present before transitioning to "H".

3) Audio interface

3-1) SDIN1~SDIN5,SDOUT1~SDOUT6,SDOUTA1 (Up to fs = 96kHz)

AKM Normal and I²S Compatible Format

(Ta = -40°C~85°C; AVDD=DVDD=3.0~3.6V, DVDD18 = 1.7~2.0V, CL=20pF)

Parameter	Symbol	min	typ	max	Unit
Slave mode CKM[2:0]=2h, 3h, 4h, 5h					
Delay time from BITCLK_I "↑" to LRCLK_I (Note 36)	tBLRD	20			ns
Delay time from LRCLK_I to BITCLK_I "↑" (Note 36)	tLRBD	20			ns
Delay time from LRCLK_I, LRCLK_O to serial data output	tLRD			40	ns
Delay time from BITCLK_I, BITCLK_O to serial data output	tBSOD			40	ns
Serial data input latch setup time	tBSIDS	40			ns
Serial data input latch hold time	tBSIDH	40			ns
Master mode CKM[2:0]=0h, 1h					
BITCLK_O frequency	fBCLK		64		fs
BITCLK_O duty cycle			50		%
Delay time from BITCLK_O "↓" to LRCLK_O	tBLRD	-20		40	ns
Delay time from LRCLK_O to serial data output	tLRD			40	ns
Delay time from BITCLK_O to serial data output	tBSOD			40	ns
Serial data input latch setup time	tBSIDS	40			ns
Serial data input latch hold time	tBSIDH	40			ns

Note 36. LRCLK_I edge and BITCLK_I "↑" edge cannot be synchronous.

3-2) SDIN1(SRCI Input) (Up to fs = 96kHz)

(Ta=-40°C~85°C; AVDD=DVDD=3.0~3.6V, DVDD18 = 1.7~2.0V)

Parameter	Symbol	min	typ	max	Unit
Slave mode					
Delay time from SRC_BICK "↑" to SRC_LRCK (Note 37)	tBLRD	20			ns
Delay time from SRC_LRCK to SRC_BICK "↑" (Note 37)	tLRBD	20			ns
Serial data input latch setup time	tBSIDS	40			ns
Serial data input latch hold time	tBSIDH	40			ns

Note 37. SRC_BICK edge and SRC_LRCK edge cannot be synchronous.

3) Microcontroller Interface

($T_a = -40 \sim 85^\circ\text{C}$; $AVDD=DVDD=3.0\text{V} \sim 3.6\text{V}$, $DVDD18 = 1.7 \sim 2.0\text{V}$, $CL = 20\text{pF}$)

Parameter	Symbol	min	typ	max	Unit
Microcomputer interface signal					
$\overline{\text{RQ}}$ Fall time	tWRF			30	ns
$\overline{\text{RQ}}$ Rise time	tWRR			30	ns
SCLK fall time	tSF			30	ns
SCLK rise time	tSR			30	ns
SCLK frequency	fSCLK			2.1	MHz
SCLK low level width	tSCLKL	200			ns
SCLK High level width	tSCLKH	200			ns
Microcomputer to AK7780					
Time from $\overline{\text{P_DSPRST}}$, $\overline{\text{P_ADRST}}$ “ \downarrow ” to $\overline{\text{RQ}}$ “ \downarrow ”	tREW	500			ns
Time from $\overline{\text{RQ}}$ “ \uparrow ” to $\overline{\text{P_DSPRST}}$, $\overline{\text{P_ADRST}}$ “ \uparrow ”	tWRE	500			ns
$\overline{\text{RQ}}$ high level width	tWRQH	500			ns
Time from $\overline{\text{RQ}}$ “ \downarrow ” to SCLK “ \downarrow ”	tWSC	500			ns
Time from SCLK “ \uparrow ” to $\overline{\text{RQ}}$ “ \uparrow ”	tSCW	800			ns
SI latch setup time	tSIS	200			ns
SI latch hold time	tSIH	200			ns
AK7780 to Microcomputer					
Delay time from SCLK “ \downarrow ” to SO output	tSOS			300	ns
Hold time from SCLK “ \uparrow ” to SO output (Note 38)	tSOH	200			ns
Time from $\overline{\text{RQ}}$ “ \downarrow ” to SO Hi-Z ($I_{\text{out}} = \pm 360\mu\text{A}$) release	tRQHR			600	ns
$\overline{\text{RQ}}$ “ \uparrow ” to SO Hi-Z set ($I_{\text{out}} = \pm 360\mu\text{A}$)	tRQHS			600	ns

Note 38. Except last 1bit of the command code.

4) I2C BUS Interface

(Ta = -40°C~85°C; AVDD=DVDD=3.0~3.6V, DVDD18 = 1.7~2.0V)

Parameter	Symbol	Min	Typ	Max	Unit
I²C Timing					
SCL clock frequency	fSCL			400	kHz
Bus Free Time Between Transmissions	tBUF	1.3			μs
Start Condition Hold Time (prior to first Clock pulse)	tHD:STA	0.6			μs
Clock Low Time	tLOW	1.3			μs
Clock High Time	tHIGH	0.6			μs
Setup Time for Repeated Start Condition	tSU:STA	0.6			μs
SDA Hold Time from SCL Falling	tHD:DAT	0		0.9	μs
SDA Setup Time from SCL Rising	tSU:DAT	0.1			μs
Rise Time of Both SDA and SCL Lines	tR			0.3	μs
Fall Time of Both SDA and SCL Lines	tF			0.3	μs
Setup Time for Stop Condition	tSU:STO	0.6			μs
Pulse Width of Spike Noise Suppressed By Input Filter	tSP	0		50	ns
Capacitive load on bus	Cb			400	pF

Note 39. I²C is a registered trademark of Philips Semiconductors.

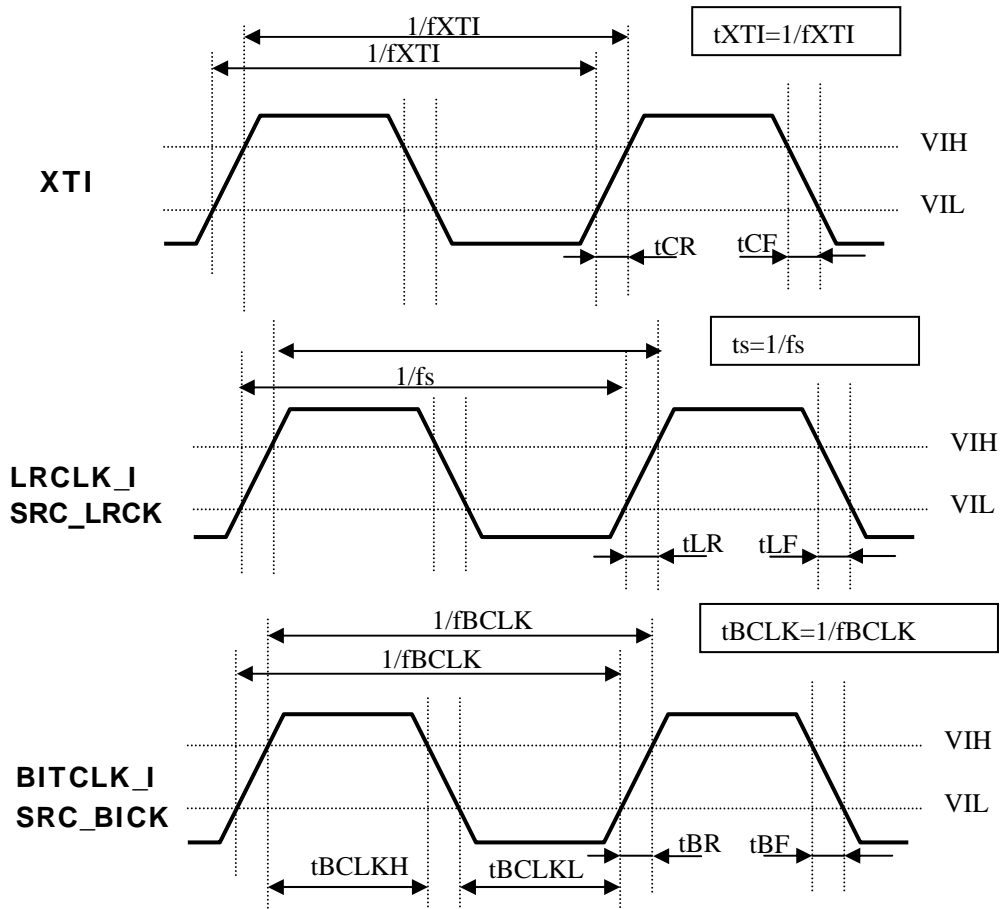
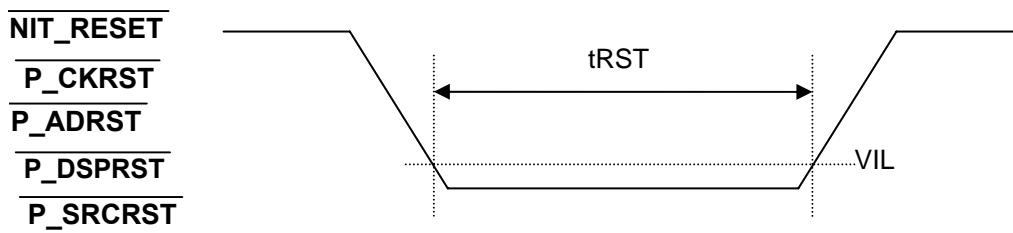
(6) Timing Diagram
1) System clock

2) RESET

3) Audio Interface

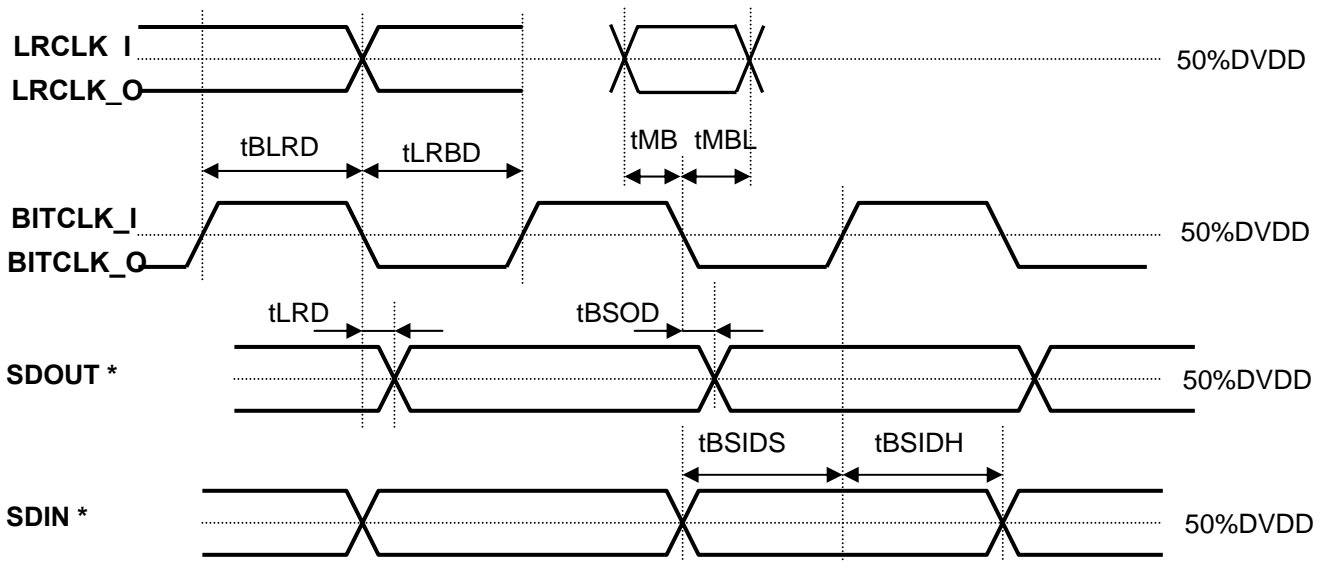
① Normal and I²S compatible format



SDIN * =SDIN1, SDIN2, SDIN3, SDIN4, SDIN5

SDOUT * =SDOUT1, SDOUT2, SDOUT3, SDOUT4, SDOUT5, SDOUT6, SDOUTA1

② SRC

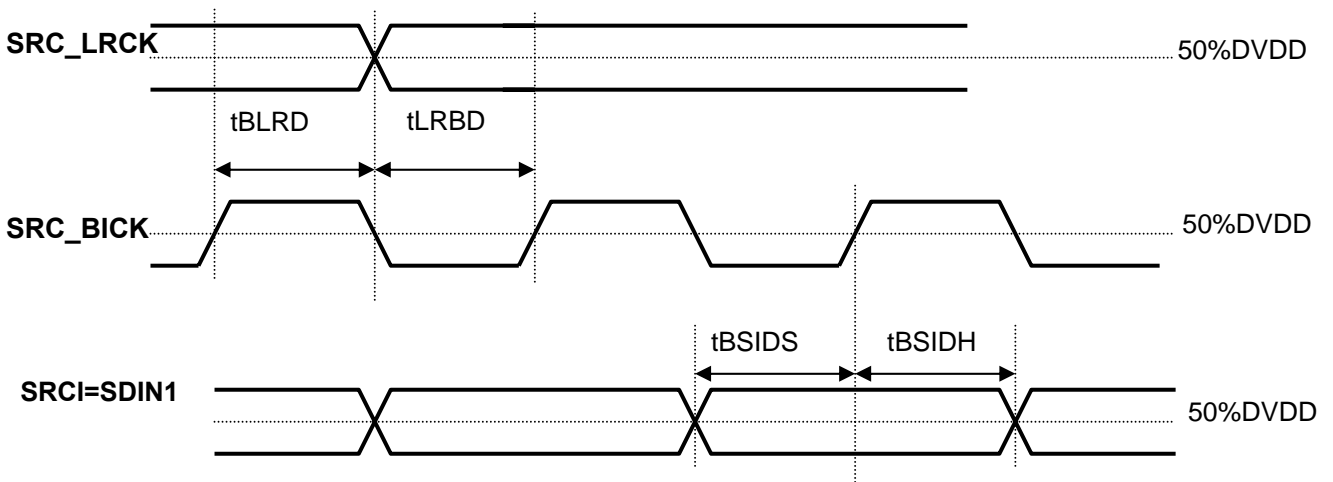

4) Microcontroller Interface

◆ Microcontroller interface

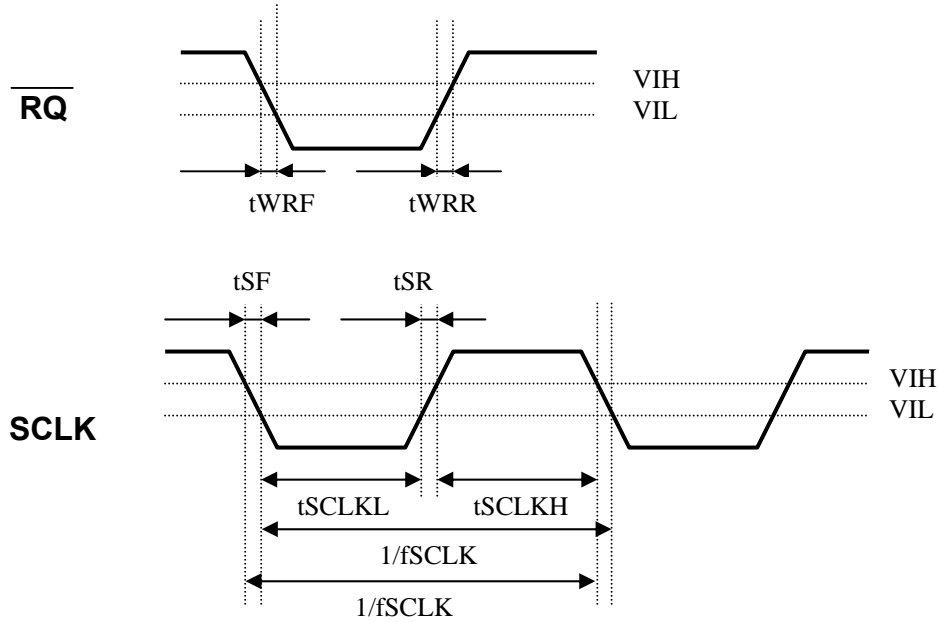

◆ Microcontrollerr → AK7780

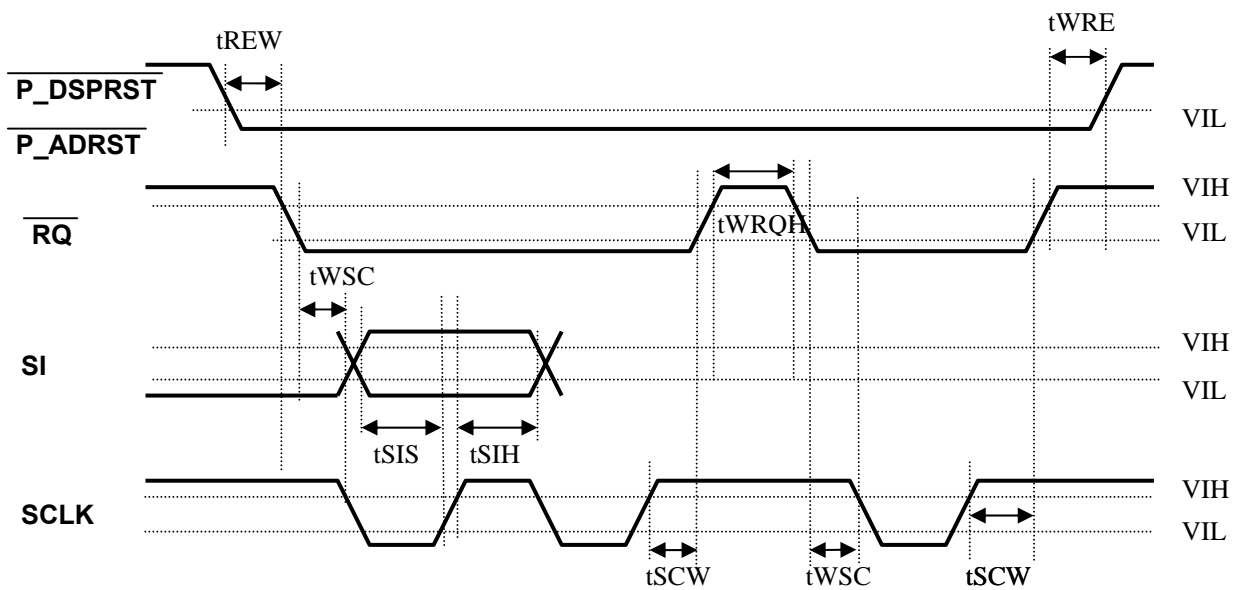

◆ AK7780 → Microcontroller

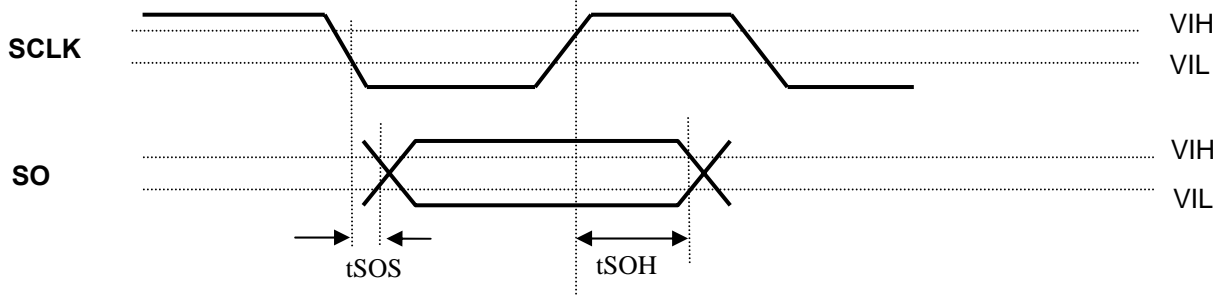

Note: Timing during the RUN state is identical, except that $\overline{P_DSPRST}$ and $\overline{P_ADRST}$ are “H”.

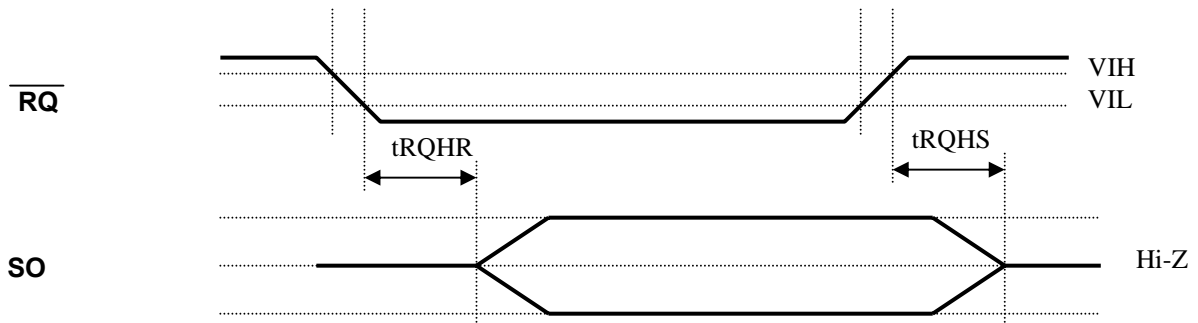
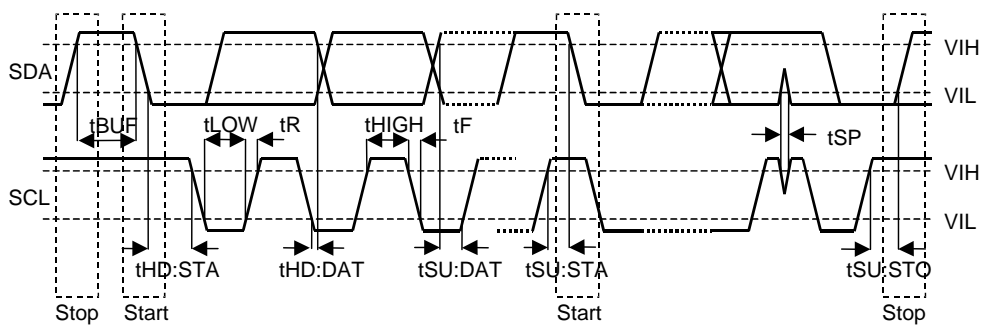
 5) I²C Bus Interface

PACKAGE

• 100 pin LQFP (Unit: mm)

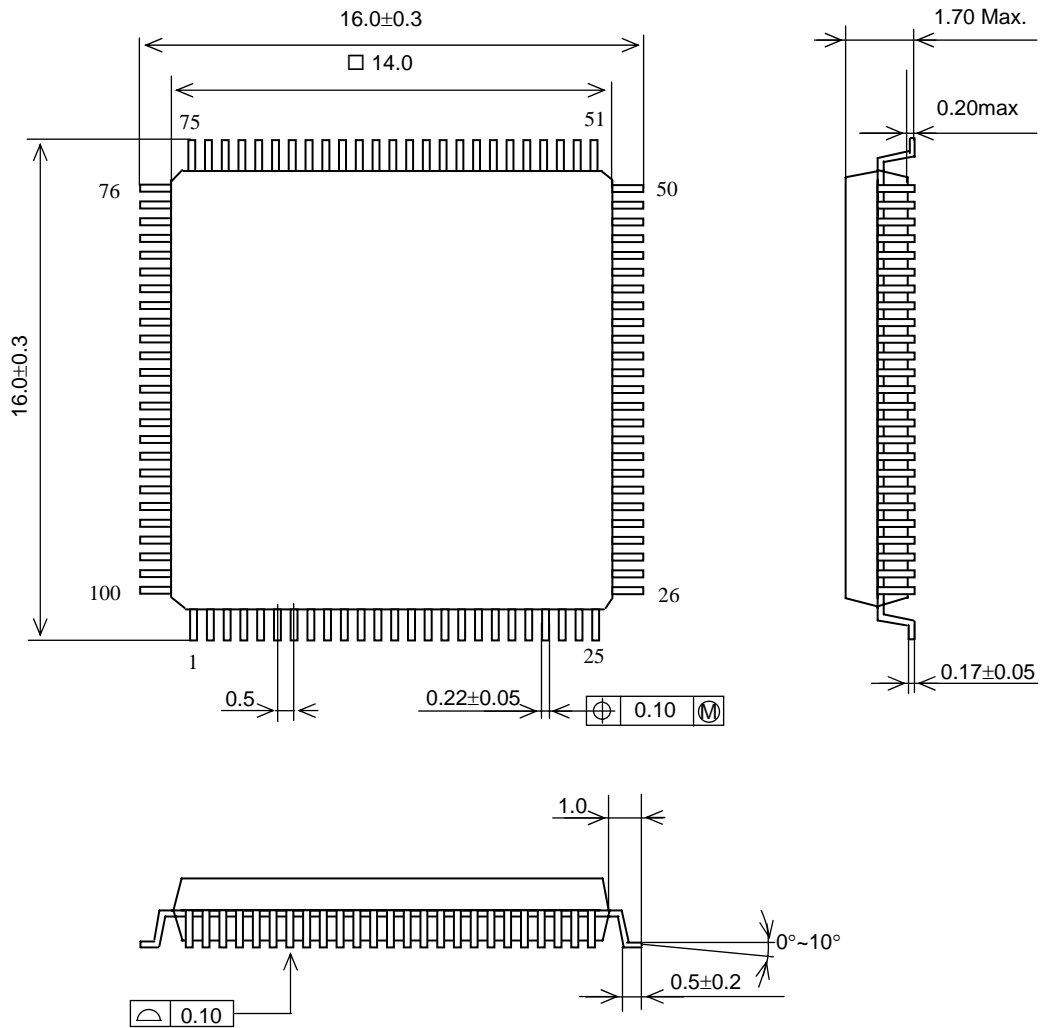

■ Material & Lead finish

Package: Epoxy
 Lead-frame: Cu
 Lead-finish: Solder (Pb free) plate

MARKING

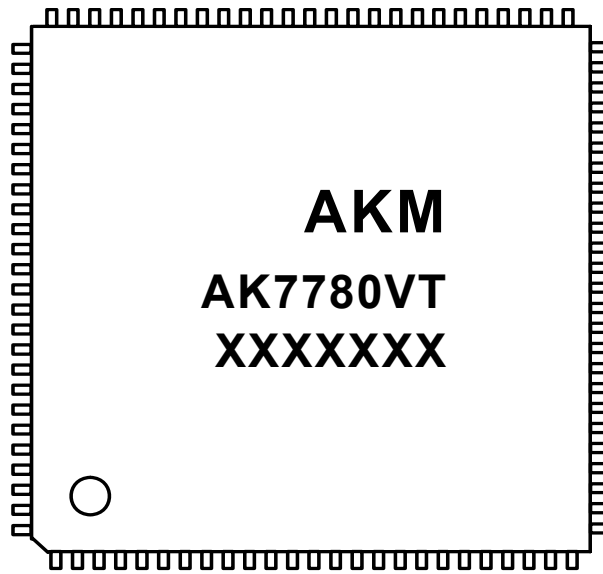

- 1) Pin #1 indication
- 2) Date Code: XXXXXXXX(7digits)
- 3) Marking Code: AK7780VT
- 4) Asahi Kasei Logo

IMPORTANT NOTICE

- These products and their specifications are subject to change without notice.
When you consider any use or application of these products, please make inquiries the sales office of Asahi Kasei EMD Corporation (AKEMD) or authorized distributors as to current status of the products.
- AKEMD assumes no liability for infringement of any patent, intellectual property, or other rights in the application or use of any information contained herein.
- Any export of these products, or devices or systems containing them, may require an export license or other official approval under the law and regulations of the country of export pertaining to customs and tariffs, currency exchange, or strategic materials.
- AKEMD products are neither intended nor authorized for use as critical components^{Note1} in any safety, life support, or other hazard related device or system^{Note2}, and AKEMD assumes no responsibility for such use, except for the use approved with the express written consent by Representative Director of AKEMD. As used here:
 - Note1) A critical component is one whose failure to function or perform may reasonably be expected to result, whether directly or indirectly, in the loss of the safety or effectiveness of the device or system containing it, and which must therefore meet very high standards of performance and reliability.
 - Note2) A hazard related device or system is one designed or intended for life support or maintenance of safety or for applications in medicine, aerospace, nuclear energy, or other fields, in which its failure to function or perform may reasonably be expected to result in loss of life or in significant injury or damage to person or property.
- It is the responsibility of the buyer or distributor of AKEMD products, who distributes, disposes of, or otherwise places the product with a third party, to notify such third party in advance of the above content and conditions, and the buyer or distributor agrees to assume any and all responsibility and liability for and hold AKEMD harmless from any and all claims arising from the use of said product in the absence of such notification.

Thank you for your access to AKEMD product informations.
More detail product informations are available, please contact
our sales office or authorized distributors.