

AsahiKASEI
ASAHI KASEI EMD

AK4648
Stereo CODEC with MIC/HP/SPK-AMP

GENERAL DESCRIPTION

The AK4648 is a stereo CODEC with a built-in Microphone-Amplifier, Headphone-Amplifier, and Speaker-Amplifier. The AK4648 features analog mixing circuits and PLL that allows easy interfacing in mobile phone and portable A/V player designs. The AK4648 is available in a CSP (3.7mm x 3.8mm), utilizing less board space than competitive offerings.

FEATURES

1. Recording Function

- 4 Stereo Inputs Selector
- Stereo Mic Input (Full-differential or Single-ended)
- Stereo Line Input
- MIC Amplifier (+32dB/+26dB/+20dB or 0dB)
- Digital ALC (Automatic Level Control)
(+36dB ~ -54dB, 0.375dB Step, Mute)
- ADC Performance: S/(N+D): 83dB, DR, S/N: 86dB (MIC-Amp=+20dB)
S/(N+D): 88dB, DR, S/N: 95dB (MIC-Amp=0dB)
- Wind-noise Reduction Filter
- Stereo Separation Emphasis
- Programmable EQ

2. Playback Function

- Digital De-emphasis Filter (tc=50/15 μ s, fs=32kHz, 44.1kHz, 48kHz)
- 5-Band Equalizer
- Soft Mute
- Digital Volume (+12dB ~ -115.0dB, 0.5dB Step, Mute)
- Digital ALC (Automatic Level Control)
(+36dB ~ -54dB, 0.375dB Step, Mute)
- Stereo Separation Emphasis
- Programmable EQ
- Stereo Line Output
 - Performance: S/(N+D): 88dB, S/N: 92dB
- Stereo Headphone-Amp
 - Support Pseudo Cap-less and Single-ended modes
 - Analog Volume: + 3dB ~ - 33dB, 3dB Step
 - S/(N+D): 70dB @ 7.5mW, S/N: 90dB
 - Output Power: 40mW @ 16 Ω (HVDD=3.6V)
62.5mW @ 16 Ω (HVDD=4.5V)
 - Pop Noise Free at Power ON/OFF
- Stereo Speaker-Amp
 - S/(N+D): 60dB @ 240mW, S/N: 90dB
 - BTL
 - Output Power: 820mW @ 8 Ω , HVDD=3.6V, High Power Mono SPK Mode
1.6W @ 8 Ω , HVDD=5V, High Power Mono SPK Mode
640mW @ 8 Ω , HVDD=3.6V, Stereo SPK & Mono SPK Mode
1.0W @ 8 Ω , HVDD=4.5V, Stereo SPK Mode
1.3W @ 8 Ω , HVDD=5V, Mono SPK Mode
 - Pop Noise Free at Power ON/OFF
- Analog Mixing: 4 Stereo Input

3. Power Management

4. Master Clock:
 - (1) PLL Mode
 - Frequencies:
 - MCKI pin: 11.2896MHz, 12MHz, 12.288MHz, 13MHz, 13.5MHz, 19.2MHz, 24MHz, 26MHz, 27MHz
 - LRCK pin: 1fs
 - BICK pin: 32fs or 64fs
 - (2) External Clock Mode
 - Frequencies: 256fs, 512fs or 1024fs (MCKI pin)
5. Output Master Clock Frequencies: 32fs/64fs/128fs/256fs
6. Sampling Rate:
 - PLL Slave Mode (LRCK pin): 7.35kHz ~ 48kHz
 - PLL Slave Mode (BICK pin): 7.35kHz ~ 48kHz
 - PLL Slave Mode (MCKI pin):
 - 8kHz, 11.025kHz, 12kHz, 16kHz, 22.05kHz, 24kHz, 32kHz, 44.1kHz, 48kHz
 - PLL Master Mode:
 - 8kHz, 11.025kHz, 12kHz, 16kHz, 22.05kHz, 24kHz, 32kHz, 44.1kHz, 48kHz
 - EXT Master/Slave Mode:
 - 7.35kHz ~ 48kHz (256fs), 7.35kHz ~ 26kHz (512fs), 7.35kHz ~ 13kHz (1024fs)
7. μ P I/F: I²C Bus (Ver 1.0, 400kHz Fast-Mode)
8. Master/Slave mode
9. Audio Interface Format: MSB First, 2's complement
 - ADC: 16bit MSB justified, I²S, DSP Mode
 - DAC: 16bit MSB justified, 16bit LSB justified, 16-24bit I²S, DSP Mode
10. Ta = -30 ~ 85°C
11. Power Supply:
 - AVDD, DVDD: 2.6 ~ 3.6V (typ. 3.3V)
 - HVDD: 2.6 ~ 5.0V (typ. 3.6V)
 - TVDD (Digital I/O): 1.6 ~ 3.6V (typ. 3.3V)
12. Package: CSP (3.7mm x 3.8mm, 0.5mm pitch)
13. Register Compatible with AK4643/4/5

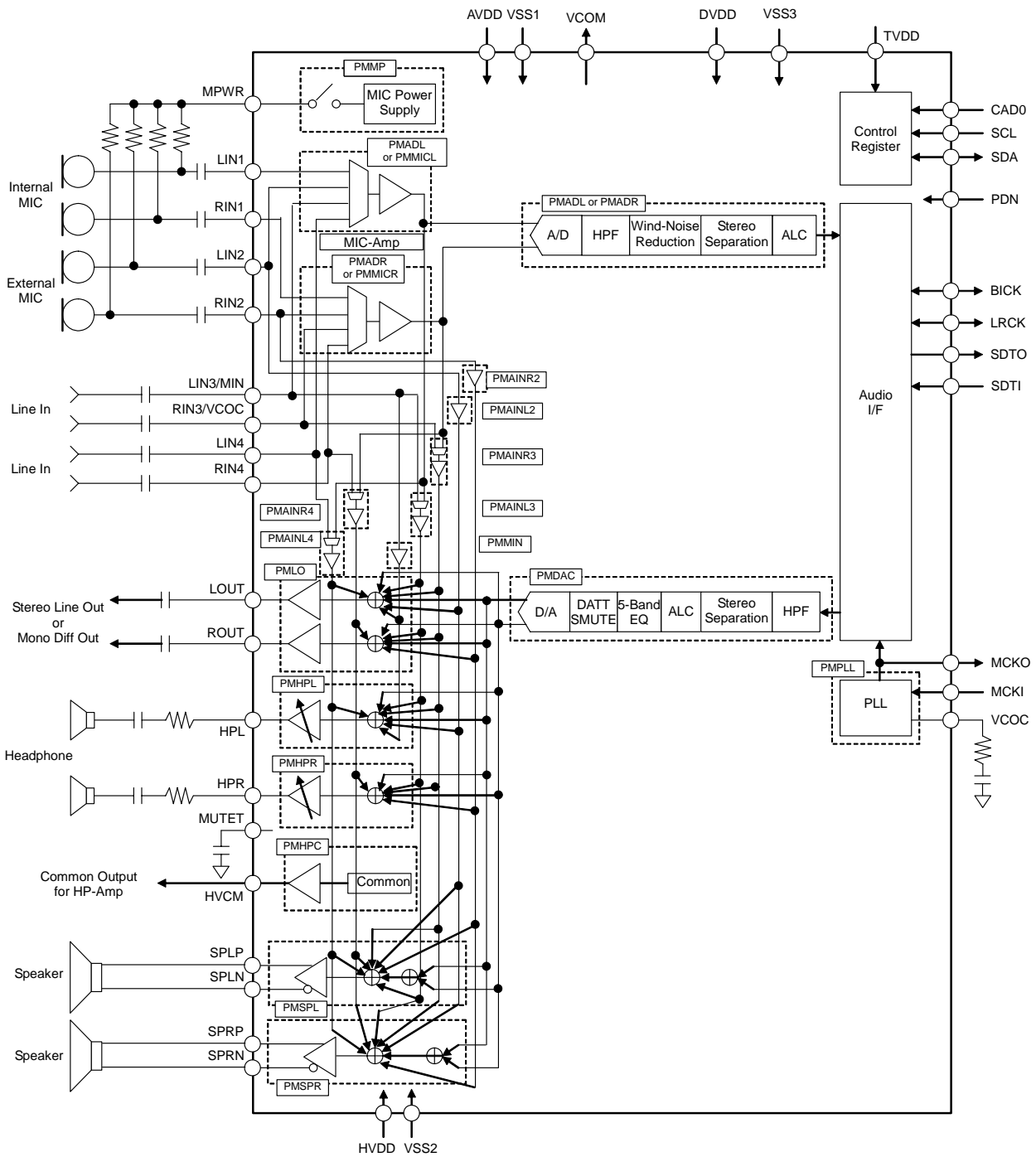
■ Block Diagram

(VCO and RIN3 pins are shared by the same pin.)

Figure 1. Block Diagram

■ Compatibility with the AK4643 and AK4645
1. Function

Function	AK4643	AK4645	AK4648
Digital I/O of μ P I/F	2.6 to 3.6V	1.6 to 3.6V	←
Analog Mixing for Playback	3 Stereo	4 Stereo	←
Input Selector for Recording	3 Stereo	4 Stereo	←
HP-Amp Hi-Z Setting for wired OR	No	Yes	←
PLL	11.2896/12/12.288/ 13.5/24/27MHz	11.2896/12/12.288/13/ 13.5/19.2/24/26/27MHz	←
Speaker-Amp	Yes (Mono)	No	Yes (Stereo)
Headphone-Amp	Yes (Po=62mW @ 3.3V)	←	Yes (Po=40mW @ 3.6V) Support Pseudo cap-less
Receiver-Amp	Yes	No	←
Bass Boost	Yes	←	No
5-band EQ	No	←	Yes
up I/F	3-wire/I2C	←	I2C
Package	32QFN (5mm x 5mm)	←	CSP (3.7x 3.8mm)

2. Register (difference from the AK4643/5)

Addr	Register Name	D7	D6	D5	D4	D3	D2	D1	D0
00H	Power Management 1	PMSPR	PMVCM	PMMIN	PMSPL	PMLO	PMDAC	0	PMADL
01H	Power Management 2	HPZ	HPMTN	PMHPL	PMHPR	M/S	PMHPC	MCKO	PMPLL
02H	Signal Select 1	SPPSN	MINS	DACS	DACL	0	PMMP	0	MGAIN0
03H	Signal Select 2	LOVL	LOPS	MGAIN1	SPKG1	SPKG0	MINL	SPKG2	0
04H	Mode Control 1	PLL3	PLL2	PLL1	PLL0	BCKO	0	DIF1	DIF0
05H	Mode Control 2	PS1	PS0	FS3	MSBS	BCKP	FS2	FS1	FS0
06H	Timer Select	DVTM	WTM2	ZTM1	ZTM0	WTM1	WTM0	RFST1	RFST0
07H	ALC Mode Control 1	0	0	ALC	ZELMN	LMAT1	LMAT0	RGAIN0	LMTH0
08H	ALC Mode Control 2	REF7	REF6	REF5	REF4	REF3	REF2	REF1	REF0
09H	Lch Input Volume Control	IVL7	IVL6	IVL5	IVL4	IVL3	IVL2	IVL1	IVL0
0AH	Lch Digital Volume Control	DVL7	DVL6	DVL5	DVL4	DVL3	DVL2	DVL1	DVL0
0BH	ALC Mode Control 3	RGAIN1	LMTH1	0	0	0	0	VBAT	0
0CH	Rch Input Volume Control	IVR7	IVR6	IVR5	IVR4	IVR3	IVR2	IVR1	IVR0
0DH	Rch Digital Volume Control	DVR7	DVR6	DVR5	DVR4	DVR3	DVR2	DVR1	DVR0
0EH	Mode Control 3	0	LOOP	SMUTE	DVOLC	0	FBEQ	DEM1	DEM0
0FH	Mode Control 4	HPG3	HPG2	HPG1	HPG0	IVOLC	HPM	MINH	DACH
10H	Power Management 3	INR1	INL1	0	MDIF2	MDIF1	INR0	INL0	PMADR
11H	Digital Filter Select	GN1	GN0	0	FIL1	EQ	FIL3	0	0
12H	FIL3 Co-efficient 0	F3A7	F3A6	F3A5	F3A4	F3A3	F3A2	F3A1	F3A0
13H	FIL3 Co-efficient 1	F3AS	0	F3A13	F3A12	F3A11	F3A10	F3A9	F3A8
14H	FIL3 Co-efficient 2	F3B7	F3B6	F3B5	F3B4	F3B3	F3B2	F3B1	F3B0
15H	FIL3 Co-efficient 3	0	0	F3B13	F3B12	F3B11	F3B10	F3B9	F3B8
16H	EQ Co-efficient 0	EQA7	EQA6	EQA5	EQA4	EQA3	EQA2	EQA1	EQA0
17H	EQ Co-efficient 1	EQA15	EQA14	EQA13	EQA12	EQA11	EQA10	EQA9	EQA8
18H	EQ Co-efficient 2	EQB7	EQB6	EQB5	EQB4	EQB3	EQB2	EQB1	EQB0
19H	EQ Co-efficient 3	0	0	EQB13	EQB12	EQB11	EQB10	EQB9	EQB8
1AH	EQ Co-efficient 4	EQC7	EQC6	EQC5	EQC4	EQC3	EQC2	EQC1	EQC0
1BH	EQ Co-efficient 5	EQC15	EQC14	EQC13	EQC12	EQC11	EQC10	EQC9	EQC8
1CH	FIL1 Co-efficient 0	F1A7	F1A6	F1A5	F1A4	F1A3	F1A2	F1A1	F1A0
1DH	FIL1 Co-efficient 1	F1AS	0	F1A13	F1A12	F1A11	F1A10	F1A9	F1A8
1EH	FIL1 Co-efficient 2	F1B7	F1B6	F1B5	F1B4	F1B3	F1B2	F1B1	F1B0
1FH	FIL1 Co-efficient 3	0	0	F1B13	F1B12	F1B11	F1B10	F1B9	F1B8
20H	Power Management 4	PMMAINR4	PMMAINL4	PMMAINR3	PMMAINL3	PMMAINR2	PMMAINL2	PMMICR	PMMICL
21H	Mode Control 5	0	SPKMN	MICR3	MICL3	L4DIF	MIX	AIN3	LODIF
22H	Lineout Mixing Select	LOM	LOM3	RINR4	LINL4	RINR3	LINL3	RINR2	LINL2
23H	HP Mixing Select	0	HPM3	RINH4	LINH4	RINH3	LINH3	RINH2	LINH2
24H	SPK Mixing Select	0	0	RINS4	LINS4	RINS3	LINS3	RINS2	LINS2
25H	EQ Control 250Hz/100Hz	FBEQB3	FBEQB2	FBEQB1	FBEQB0	FBEQA3	FBEQA2	FBEQA1	FBEQA0
26H	EQ Control 3.5kHz/1kHz	FBEQD3	FBEQD2	FBEQD1	FBEQD0	FBEQC3	FBEQC2	FBEQC1	FBEQC0
27H	EQ Control 10kHz	0	0	0	0	FBEQE3	FBEQE2	FBEQE1	FBEQE0

XXX	These bits are changed from the AK4645.
XXX	These bits are changed from the AK4643.
XXX	These bits are changed from the AK4643/5.

■ Ordering Guide

 AK4648EC
 AKD4648

-30 ~ +85°C

CSP (3.7mm x 3.8mm, 0.5mm pitch)

Evaluation board for AK4648

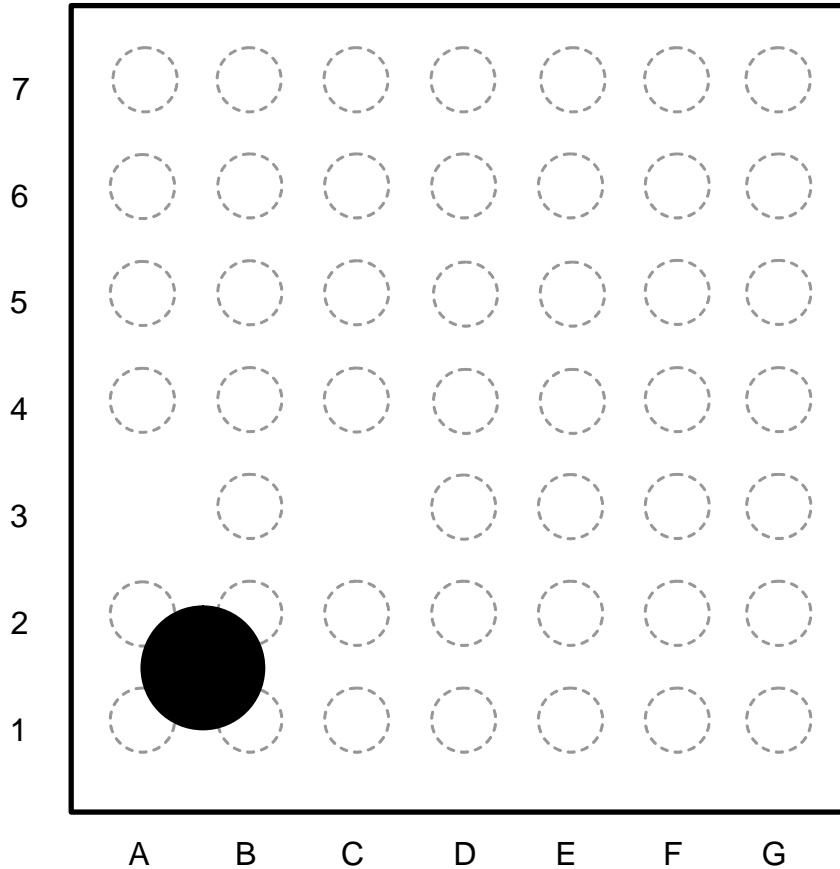
■ Pin Layout
Top View

Top View

7	TEST	VCOM	AVDD	LIN1/IN1-	MPWR	CAD0	NC
6	LIN4/IN4+	RIN2/IN2-	MIN/LIN3	VSS1	VCOC/RIN3	SCL	SDTI
5	ROUT/LON	LOUT/LOP	LIN2/IN2+	NC	NC	RIN1/IN1+	LRCK
4	SPRP	SPRN	RIN4/IN4-	NC	NC	SDA	BICK
3		VSS2		HPL	DVDD	SDTO	MCKO
2	HVDD	SPLP	HVCM	HPR	PDN	TVDD	TVDD
1	NC	SPLN	VSS2	MUTET	VSS3	MCKI	NC
	A	B	C	D	E	F	G

PIN/FUNCTION

No.	Pin Name	I/O	Function
A1, D4, D5, E4, E5, G1 G7	NC	-	No Connection Pin This should be connected to ground (VSS1, VSS2 or VSS3 pin).
A2	HVDD	-	Headphone Amp Power Supply Pin, 2.6 ~ 5.0V
A4	SPRP	O	Rch Speaker-Amp Positive Output Pin
A5	ROUT	O	Rch Stereo Line Output Pin (LODIF bit = "0": Single-ended Stereo Output)
	LON	O	Negative Line Output Pin (LODIF bit = "1": Full-differential Mono Output)
A6	LIN4	I	Lch Analog Input 4 Pin (L4DIF bit = "0": Single-ended Input)
	IN4+	I	Positive Line Input 4 Pin (L4DIF bit = "1": Full-differential Input)
A7	TEST	O	Test Pin This pin should be open.
B1	SPLN	O	Lch Speaker-Amp Negative Output Pin
B2	SPLP	O	Lch Speaker-Amp Positive Output Pin
B3, C1	VSS2	-	Ground 2 Pin
B4	SPRN	O	Rch Speaker-Amp Negative Output Pin
B5	LOUT	O	Lch Stereo Line Output Pin (LODIF bit = "0": Single-ended Stereo Output)
	LOP	O	Positive Line Output Pin (LODIF bit = "1": Full-differential Mono Output)
B6	RIN2	I	Rch Analog Input 2 Pin (MDIF2 bit = "0": Single-ended Input)
	IN2-	I	Microphone Negative Input 2 Pin (MDIF2 bit = "1": Full-differential Input)
B7	VCOM	O	Common Voltage Output Pin, 0.45 x AVDD Bias voltage of ADC inputs and DAC outputs.
C2	HVCM	O	Headphone-Amp Common Voltage Output Pin
C4	RIN4	I	Rch Analog Input 4 Pin (L4DIF bit = "0": Single-ended Input)
	IN4-	I	Negative Line Input 4 Pin (L4DIF bit = "1": Full-differential Input)
C5	LIN2	I	Lch Analog Input 2 Pin (MDIF2 bit = "0": Single-ended Input)
	IN2+	I	Microphone Positive Input 2 Pin (MDIF2 bit = "1": Full-differential Input)
C6	MIN	I	Mono Signal Input Pin (AIN3 bit = "0": PLL is available.)
	LIN3	I	Lch Analog Input 3 Pin (AIN3 bit = "1": PLL is not available.)
C7	AVDD	-	Analog Power Supply Pin, 2.6 ~ 3.6V
D1	MUTET	O	Mute Time Constant Control Pin Connected to VSS2 pin with a capacitor for mute time constant.
D2	HPR	O	Rch Headphone-Amp Output Pin
D3	HPL	O	Lch Headphone-Amp Output Pin
D6	VSS1	-	Ground 1 Pin
D7	LIN1	I	Lch Analog Input 4 Pin (MDIF1 bit = "0": Single-ended Input)
	IN1-	I	Microphone Negative Input 1 Pin (MDIF1 bit = "1": Full-differential Input)
E1	VSS3	-	Ground 3 Pin
E2	PDN	I	Power-Down Mode Pin "H": Power-up, "L": Power-down, reset and initializes the control register.
E3	DVDD	-	Digital Power Supply Pin, 2.6 ~ 3.6V
E6	VCOC	O	Output Pin for Loop Filter of PLL Circuit (AIN3 bit = "0": PLL is available.) This pin should be connected to VSS1 with one resistor and capacitor in series.
	RIN3	I	Rch Analog Input 3 Pin (AIN3 bit = "1": PLL is not available.)
E7	MPWR	O	MIC Power Supply Pin
F1	MCKI	I	External Master Clock Input Pin
F2, G2	TVDD	-	Digital I/O Power Supply Pin, 1.6 ~ 3.6V
F3	SDTO	O	Audio Serial Data Output Pin
F4	SDA	I/O	Control Data Input/Output Pin
F5	RIN1	I	Rch Analog Input 1 Pin (MDIF1 bit = "0": Single-ended Input)
	IN1+	I	Microphone Positive Input 1 Pin (MDIF1 bit = "1": Full-differential Input)

PIN/FUNCTION (cont.)

No.	Pin Name	I/O	Function
F6	SCL	I	Control Data Clock Pin
F7	CAD0	I	Chip Address Select Pin
G3	MCKO	O	Master Clock Output Pin
G4	BICK	I/O	Audio Serial Data Clock Pin
G5	LRCK	I/O	Input / Output Channel Clock Pin
G6	SDTI	I	Audio Serial Data Input Pin

Note 1. All input pins except analog input pins (MIN/LIN3, LIN1, RIN1, LIN2, RIN2, RIN3, RIN4, and LIN4 pins) should not be left floating.

Note 2. All analog input pins (MIN/LIN3, LIN1, RIN1, LIN2, RIN2, RIN3, LIN4, and RIN4 pins) should supply signal via AC-coupling capacitor.

Note 3. Analog output pins (HPL, HPR, LOUT, and ROUT pins) except speaker output (SPLP, SPLN, SPRP and SPRN pins) and headphone output in Pseudo cap-less mode (HPL and HPR pins) should deliver signal via AC-coupling capacitor.

■ Handling of Unused Pin

The unused I/O pins should be processed appropriately as below.

Classification	Pin Name	Setting
Analog	MPWR, VCOC/RIN3, HPR, HPL, MUTET, RIN4/IN4-, LIN4/IN4+, ROUT/LON, LOUT/LOP, MIN/LIN3, RIN2/IN2-, LIN2/IN2+, LIN1/IN1-, RIN1/IN1+, SPRP, SPRN, HVCM, SPLP, SPLN, TEST	These pins should be open.
Digital	MCKI, SDTI	These pins should be connected to VSS3.
	MCKO, SDTO	These pins should be open.

ABSOLUTE MAXIMUM RATINGS

(VSS1, VSS2, VSS3=0V; Note 4, Note 5)

Parameter		Symbol	min	max	Units
Power Supplies: (Note 5)	Analog	AVDD	-0.3	6.0	V
	Digital	DVDD	-0.3	6.0	V
	Digital I/O	TVDD	-0.3	6.0	V
	Headphone-Amp	HVDD	-0.3	6.0	V
Input Current, Any Pin Except Supplies		IIN	-	±10	mA
Analog Input Voltage (Note 6)		VINA	-0.3	AVDD+0.3	V
Digital Input Voltage (Note 7)		VIND	-0.3	TVDD+0.3	V
Ambient Temperature (powered applied)		Ta	-30	85	°C
Storage Temperature		Tstg	-65	150	°C
Maximum Power Dissipation (Note 8)	Ta = 85°C (Note 9)	Pd1	-	1.2	W
	Ta = 70°C (Note 10)	Pd2	-	1.46	W

Note 4. All voltages with respect to ground.

Note 5. VSS1, VSS2, and VSS3 must be connected to the same analog ground plane.

Note 6. RIN4/IN4-, LIN4/IN4+, MIN/LIN3, RIN3, RIN2/IN2-, LIN2/IN2+, LIN1/IN1-, and RIN1/IN1+ pins

Note 7. PDN, SCL, SDA, SDTI, LRCK, BICK, MCKI, and CAD0 pins

Pull-up resistors at SDA and SCL pins should be connected to (TVDD+0.3) V or less voltage.

Note 8. In case that PCB wiring density is 300% or more. This power is the AK4648 internal dissipation that does not include power of externally connected speaker and headphone.

Note 9. Stereo SPK Mode is not available.

Note 10. In case of Stereo SPK Mode, Ta (max) is 70°C and HVDD voltage range is from 2.6V to 4.6V.

WARNING: Operation at or beyond these limits may result in permanent damage to the device.

Normal operation is not guaranteed at these extremes.

RECOMMENDED OPERATING CONDITIONS

(VSS1, VSS2, VSS3=0V; Note 4)

Parameter		Symbol	min	typ	max	Units
Power Supplies (Note 11)	Analog	AVDD	2.6	3.3	3.6	V
	Digital	DVDD	2.6	3.3	3.6	V
	Digital I/O	TVDD	1.6	3.3	DVDD	V
	HP/SPK-Amp	HVDD	2.6	3.6	5.0	V
	Difference	AVDD-DVDD	-0.3	0	+0.3	V

Note 4. All voltages with respect to ground.

Note 11. The power-up sequence among AVDD, DVDD, TVDD, and HVDD is not critical. PDN pin should be held to “L” upon power-up. PDN pin should be set to “H” after all power supplies are powered-up. The AK4648 should be operated by the recommended power-up/down sequence shown in “System Design (Grounding and Power Supply Decoupling)” to avoid the pop noise at speaker output, line output and headphone output.

The AK4648 supports the following two cases of partial power ON/OFF. In these cases, the PDN pin must be “L”.

1. TVDD=HVDD=ON: AVDD=DVDD can be power ON/OFF.
2. TVDD=ON: AVDD=DVDD=HVDD can be power ON/OFF.

When the power state is changed from OFF to ON in the above cases, the PDN pin should be changed from “L” to “H” after all power supply pins are supplied. “L” time of 150ns or more is needed to reset the AK4648.

* AKEMD assumes no responsibility for the usage beyond the conditions in this datasheet.

ANALOG CHARACTERISTICS

(Ta=25°C; AVDD, DVDD, TVDD=3.3V, HVDD=3.6V; VSS1=VSS2=VSS3=0V; fs=44.1kHz, BICK=64fs; Signal Frequency=1kHz; 16bit Data; Measurement frequency=20Hz ~ 20kHz; unless otherwise specified)

Parameter		min	typ	max	Units
MIC Amplifier: LIN1/RIN1/LIN2/RIN2/LIN4/RIN4 pins & LIN3/RIN3 pins (AIN3 bit = "1"); PMAINL2=PMAINR2=PMAINL3=PMAINR3=PMAINL4=PMAINR4 bits = "0"; MDIF1=MDIF2 bits = "0" (Single-ended inputs)					
Input Resistance	MGAIN1-0 bits = "00"	40	60	80	kΩ
	MGAIN1-0 bits = "01", "10" or "11"	20	30	40	kΩ
Gain	MGAIN1-0 bits = "00"	-	0	-	dB
	MGAIN1-0 bits = "01"	-	+20	-	dB
	MGAIN1-0 bits = "10"	-	+26	-	dB
	MGAIN1-0 bits = "11"	-	+32	-	dB
MIC Amplifier: IN1+/IN1-/IN2+/IN2- pins; MDIF1 = MDIF2 bits = "1" (Full-differential input)					
Input Voltage (Note 12)					
	MGAIN1-0 bits = "00"	-	-	1.155	Vpp
	MGAIN1-0 bits = "01"	-	-	0.228	Vpp
	MGAIN1-0 bits = "10"	-	-	0.114	Vpp
	MGAIN1-0 bits = "11"	-	-	0.057	Vpp
MIC Power Supply: MPWR pin					
Output Voltage (Note 13)		2.22	2.47	2.72	V
Load Resistance		0.5	-	-	kΩ
Load Capacitance		-	-	30	pF
ADC Analog Input Characteristics: LIN1/RIN1/LIN2/RIN2/LIN4/RIN4 pins & LIN3/RIN3 pins (AIN3 bit = "1") → ADC → IVOL, IVOL=0dB, ALC=OFF					
Resolution		-	-	16	Bits
Input Voltage (Note 14)	(Note 15)	0.168	0.198	0.228	Vpp
	(Note 16)	1.68	1.98	2.28	Vpp
S/(N+D) (-1dBFS)	(Note 15, LIN1/RIN1/LIN2/RIN2)	71	83	-	dBFS
	(Note 15, LIN3/RIN3/LIN4/RIN4)	-	83	-	dBFS
	(Note 16, except for LIN3/RIN3)	-	88	-	dBFS
	(Note 16, LIN3/RIN3)	-	72	-	dBFS
D-Range (-60dBFS, A-weighted)	(Note 15)	76	86	-	dB
	(Note 16)	-	95	-	dB
S/N (A-weighted)	(Note 15)	76	86	-	dB
	(Note 16)	-	95	-	dB
Interchannel Isolation	(Note 15)	75	90	-	dB
	(Note 16)	-	100	-	dB
Interchannel Gain Mismatch	(Note 15)	-	0.1	0.8	dB
	(Note 16)	-	0.1	0.8	dB

Note 12. The voltage difference between IN1/2+ and IN1/2- pins. AC coupling capacitor should be inserted in series at each input pin. Maximum input voltage of IN1+, IN1-, IN2+ and IN2- pins is proportional to AVDD voltage, respectively.

$V_{in} = |(IN+) - (IN-)| = 0.35 \times AVDD$ (max) @ MGAIN1-0 bits = "00", $0.069 \times AVDD$ (max.) @ MGAIN1-0 bits = "01", $0.035 \times AVDD$ (max.) @ MGAIN1-0 bits = "10", $0.017 \times AVDD$ (max.) @ MGAIN1-0 bits = "11".

When MGAIN1-0 bits = "00", the full scale level can not be input to ADC. The input level is -6dBFS @ IVL/R = 0dB". When the signal larger than above value is input to IN1+, IN1-, IN2+ or IN2- pin, ADC does not operate normally.

Note 13. Output voltage is proportional to AVDD voltage. $V_{out} = 0.75 \times AVDD$ (typ.)

Note 14. Input voltage is proportional to AVDD voltage. $V_{in} = 0.06 \times AVDD$ (typ.) @ MGAIN1-0 bits = "01" (+20dB),
 $V_{in} = 0.6 \times AVDD$ (typ.) @ MGAIN1-0 bits = "00" (0dB)

Note 15. MGAIN1-0 bits = "01" (+20dB)

Note 16. MGAIN1-0 bits = "00" (0dB)

Parameter		min	typ	max	Units
DAC Characteristics:					
Resolution		-	-	16	Bits
Stereo Line Output Characteristics: DAC → LOUT/ROUT pins, ALC=OFF, IVOL=0dB, DVOL=0dB, LOVL bit = "0", LODIF bit = "0", $R_L=10k\Omega$ (Single-ended); unless otherwise specified.					
Output Voltage (Note 17)	LOVL bit = "0"	1.78	1.98	2.18	V_{pp}
	LOVL bit = "1"	2.25	2.50	2.75	V_{pp}
S/(N+D) (-3dBFS)		78	88	-	dBFS
S/N (A-weighted)		82	92	-	dB
Interchannel Isolation		80	100	-	dB
Interchannel Gain Mismatch		-	0.1	0.5	dB
Load Resistance		10	-	-	k Ω
Load Capacitance		-	-	30	pF
Mono Line Output Characteristics: DAC → LOP/LON pins, ALC=OFF, IVOL=0dB, DVOL=0dB, LOVL bit = "0", LODIF bit = "1", $R_L=10k\Omega$ for each pin (Full-differential)					
Output Voltage (Note 18)	LOVL bit = "0"	3.52	3.96	4.36	V_{pp}
	LOVL bit = "1"	-	5.00	-	V_{pp}
S/(N+D) (-3dBFS)		78	88	-	dBFS
S/N (A-weighted)		85	95	-	dB
Load Resistance (LOP/LON pins, respectively)		10	-	-	k Ω
Load Capacitance (LOP/LON pins, respectively)		-	-	30	pF

Note 17. Output voltage is proportional to AVDD voltage. $V_{out} = 0.6 \times AVDD$ (typ.)@LOVL bit = "0".

Note 18. Output voltage is proportional to AVDD voltage. $V_{out} = (LOP) - (LON) = 0.59 \times AVDD$ (typ.)@LOVL bit = "0", -6dBFS.

Parameter	min	typ	max	Units	
Headphone-Amp Characteristics in Single-ended mode:					
DAC → HPL/HPR pins, ALC=OFF, IVOL=0dB, DVOL=0dB; VBAT bit = "0"; PMHPC bit = "0"; unless otherwise specified.					
Headphone Volume (HPG3-0 bits)					
Volume Range	-33	-	+3	dB	
Gain Step: +3dB to -33dB	1.5	3	4.5	dB	
Output Voltage (Note 19)					
HPG = 0dB, 0dBFS, HVDD=3.6V, $R_L=22.8\Omega$	1.58	1.98	2.38	V _{pp}	
HPG = +3dB, 0dBFS, HVDD=4.5V, $R_L=100\Omega$	2.24	2.8	3.36	V _{pp}	
HPG = +3dB, -2dBFS, HVDD=3.6V, $R_L=16\Omega$ (Po=40mW)	-	0.8	-	V _{rms}	
HPG = +3dB, 0dBFS, HVDD=4.5V, $R_L=16\Omega$ (Po=62.5mW)	-	1.0	-	V _{rms}	
S/(N+D)					
HPG = 0dB, -3dBFS, HVDD=3.6V, $R_L=22.8\Omega$	60	70	-	dBFS	
HPG = +3dB, -3dBFS, HVDD=4.5V, $R_L=100\Omega$	-	75	-	dBFS	
HPG = +3dB, -2dBFS, HVDD=3.6V, $R_L=16\Omega$ (Po=40mW)	-	60	-	dBFS	
HPG = +3dB, 0dBFS, HVDD=4.5V, $R_L=16\Omega$ (Po=62.5mW)	-	60	-	dBFS	
S/N (A-weighted)	(Note 20)	80	90	-	dB
	(Note 21)	-	90	-	dB
Interchannel Isolation	(Note 20)	65	75	-	dB
	(Note 21)	-	80	-	dB
Interchannel Gain Mismatch	(Note 20)	-	0.1	0.8	dB
	(Note 21)	-	0.1	0.8	dB
Load Resistance	16	-	-	Ω	
Load Capacitance	C1 in Figure 2	-	-	30	pF
	C2 in Figure 2	-	-	300	pF

Note 19. Output voltage is proportional to AVDD voltage.

$$V_{out} = 0.6 \times AVDD(\text{typ.}) @ \text{HPG} = 0\text{dB}, 0.848 \times AVDD(\text{typ.}) @ \text{HPG} = +3\text{dB}$$

Note 20. HPG = 0dB, HVDD=3.6V, $R_L=22.8\Omega$.

Note 21. HPG = +3dB, HVDD=4.5V, $R_L=100\Omega$.

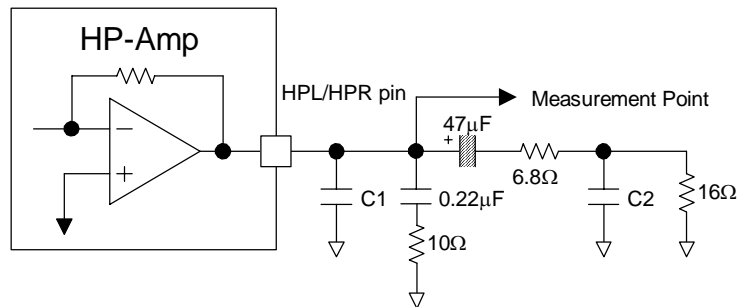

Figure 2. Example external output circuit of HP-Amp in Single-ended mode

Parameter	min	typ	max	Units	
Headphone-Amp Characteristics in Pseudo Cap-less mode:					
DAC → HPL/HPR pins, ALC=OFF, IVOL=0dB, DVOL=0dB; VBAT bit = "0"; PMHPC bit = "1"; unless otherwise specified.					
Headphone Volume (HPG3-0 bits)					
Volume Range	-33	-	+3	dB	
Gain Step: +3dB to -33dB	1.5	3	4.5	dB	
Output Voltage (Note 22)					
HPG = 0dB, 0dBFS, HVDD=3.6V, $R_L=22.8\Omega$	1.58	1.98	2.38	V _{pp}	
HPG = +3dB, 0dBFS, HVDD=4.5V, $R_L=100\Omega$	2.24	2.8	3.36	V _{pp}	
HPG = +3dB, -2dBFS, HVDD=3.6V, $R_L=16\Omega$ (Po=40mW)	-	0.8	-	V _{rms}	
HPG = +3dB, 0dBFS, HVDD=4.5V, $R_L=16\Omega$ (Po=62.5mW)	-	1.0	-	V _{rms}	
S/(N+D)					
HPG = 0dB, -3dBFS, HVDD=3.6V, $R_L=22.8\Omega$	30	50	-	dBFS	
HPG = +3dB, -3dBFS, HVDD=4.5V, $R_L=100\Omega$	-	60	-	dBFS	
HPG = +3dB, -2dBFS, HVDD=3.6V, $R_L=16\Omega$ (Po=40mW)	-	45	-	dBFS	
HPG = +3dB, 0dBFS, HVDD=4.5V, $R_L=16\Omega$ (Po=62.5mW)	-	40	-	dBFS	
S/N (A-weighted)	(Note 23)	80	90	-	dB
	(Note 24)	-	90	-	dB
Interchannel Isolation	(Note 23)	40	50	-	dB
	(Note 24)	-	60	-	dB
Interchannel Gain Mismatch	(Note 23)	-	0.1	0.8	dB
	(Note 24)	-	0.1	0.8	dB
Load Resistance (Note 25)	16	-	-	Ω	
Load Capacitance	C1 in Figure 3	-	-	30	pF
	C2 in Figure 3	-	-	300	pF

Note 22. Output voltage is proportional to AVDD voltage.

$$V_{out} = 0.6 \times AVDD(\text{typ.}) @ \text{HPG} = 0\text{dB}, 0.848 \times AVDD(\text{typ.}) @ \text{HPG} = +3\text{dB}$$

Note 23. HPG = 0dB, HVDD=3.6V, $R_L=22.8\Omega$

Note 24. HPG = +3dB, HVDD=4.5V, $R_L=100\Omega$

Note 25. Load resistance is inserted between HPL pin (HPR pin) and HVCM pin.

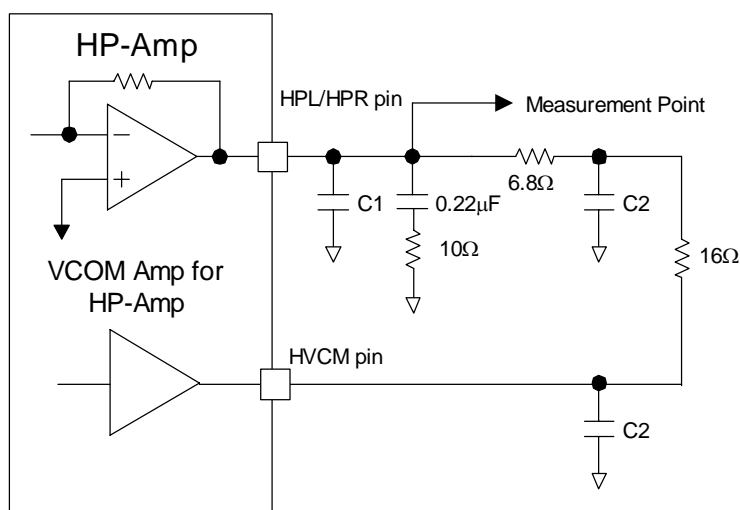

Note: Impedance between headphone and HVCM pin should be as lower as possible. If the impedance is larger, crosstalk and distortion might be degraded.

Figure 3. Example external output circuit of HP-Amp in Pseudo Cap-less Mode

Parameter	min	typ	max	Units
Speaker-Amp Characteristics: DAC → SPP/SPN pins, ALC=OFF, IVOL=0dB, DVOL=0dB, $R_L=8\Omega$, BTL, HVDD=3.6V; unless otherwise specified.				
Output Voltage (Note 26)				
SPKG2-0 bits = "000", -0.5dBFS ($P_o=150mW$)	-	3.11	-	V_{pp}
SPKG2-0 bits = "001", -0.5dBFS ($P_o=240mW$)	3.13	3.92	4.71	V_{pp}
HVDD=3.6V, SPKG2-0 bits = "011", Mono/Stereo SPK Mode; -1.5dBFS ($P_o=0.6W$)	-	2.27	-	V_{rms}
HVDD=3.6V, SPKG2-0 bits = "011", High Power Mono SPK Mode, 0dBFS ($P_o=0.8W$)	-	2.56	-	V_{rms}
HVDD=4.5V, SPKG2-0 bits = "011", 0dBFS ($P_o=1W$)	-	2.83	-	V_{rms}
Line Input → SPLP/SPLN or SPRP/SPRN pins, HVDD=4.5V, SPKG2-0 bits = "011", -2.3dBV Input ($P_o=1W$)	-	2.83	-	V_{rms}
S/(N+D)				
SPKG2-0 bits = "000", -0.5dBFS ($P_o=150mW$)	-	60	-	dB
SPKG2-0 bits = "001", -0.5dBFS ($P_o=240mW$)	20	60	-	dB
HVDD=3.6V, SPKG2-0 bits = "011", Mono/Stereo SPK Mode, -1.5dBFS ($P_o=0.6W$)	-	20	-	dB
HVDD=3.6V, SPKG2-0 bits = "011", High Power Mono SPK Mode, 0dBFS ($P_o=0.8W$)	-	20	-	dB
HVDD=4.5V, SPKG2-0 bits = "011", 0dBFS ($P_o=1W$)	-	20	-	dB
Line Input → SPLP/SPLN or SPRP/SPRN pins, HVDD=4.5V, SPKG2-0 bits = "011", Mono/Stereo SPK Mode, -2.3dBV Input ($P_o=1W$)	-	20	-	dB
Line Input → SPLP/SPLN or SPRP/SPRN pins, HVDD=5V, SPKG2-0 bits = "011", Mono SPK Mode, -1.3dBV Input ($P_o=1.3W$)	-	20	-	dB
Line Input → SPLP/SPLN or SPRP/SPRN pins, HVDD=5V, SPKG2-0 bits = "011", High Power Mono SPK Mode, -0.3dBV Input ($P_o=1.6W$)	-	20	-	dB
S/N (A-weighted)	80	90	-	dB
Interchannel Gain Mismatch (SPKMN bit = "1")	-	0.5	-	dB
Interchannel Isolation (SPKMN bit = "1")	-	90	-	dB
Load Resistance	8	-	-	Ω
Load Capacitance	-	-	30	pF

Note 26. Output voltage is proportional to AVDD voltage.

$V_{out} = 0.94 \times AVDD$ (typ.)@SPKG2-0 bits = "000", $1.19 \times AVDD$ (typ.)@SPKG2-0 bits = "001", $2.05 \times AVDD$ (typ.)@SPKG2-0 bits = "010", $2.58 \times AVDD$ (typ.) @ SPKG2-0 bits = "011", $0.6 \times AVDD$ (typ.) @ SPKG2-0 bits = "100", $0.3 \times AVDD$ (typ.) @ SPKG2-0 bits = "101" at Full-differential output.

Note 27. In case of measuring at SPLP (SPRP) and SPLN (SPRN) pins

Parameter	min	typ	max	Units	
Mono Input: MIN pin (AIN3 bit = "0"; External Input Resistance=20kΩ)					
Maximum Input Voltage (Note 28)	-	1.98	-	V _{pp}	
Gain (Note 29)					
MIN → LOU _T /ROU _T	LOVL bit = "0"	-4.5	0	+4.5	dB
	LOVL bit = "1"	-	+2	-	dB
MIN → HPL/HPR	HPG = 0dB	-24.5	-20	-15.5	dB
MIN → SPLP/SPLN or SPRP/SPRN					
	ALC bit = "0", SPKG2-0 bits = "000"	-0.07	+4.43	+8.93	dB
	ALC bit = "0", SPKG2-0 bits = "001"	-	+6.43	-	dB
	ALC bit = "0", SPKG2-0 bits = "010"	-	+10.65	-	dB
	ALC bit = "0", SPKG2-0 bits = "011"	-	+12.65	-	dB
	ALC bit = "0", SPKG2-0 bits = "100"	-	0	-	dB
	ALC bit = "0", SPKG2-0 bits = "101"	-	-6	-	dB
	ALC bit = "1", SPKG2-0 bits = "000"	-	+6.43	-	dB
	ALC bit = "1", SPKG2-0 bits = "001"	-	+8.43	-	dB
	ALC bit = "1", SPKG2-0 bits = "010"	-	+12.65	-	dB
	ALC bit = "1", SPKG2-0 bits = "011"	-	+14.65	-	dB
	ALC bit = "1", SPKG2-0 bits = "100"	-	+2	-	dB
	ALC bit = "1", SPKG2-0 bits = "101"	-	-4	-	dB

Note 28. Maximum voltage is in proportion to both AVDD and external input resistance (R_{in}).

$$V_{in} = 0.6 \times AVDD \times R_{in} / 20k\Omega \text{ (typ.)}$$

Note 29. The gain is in inverse proportion to external input resistance.

Parameter		min	typ	max	Units
Stereo Input: LIN2/RIN2/LIN4/RIN4 pins; LIN3/RIN3 pins (AIN3 bit = "1")					
Maximum Input Voltage (Note 30)		-	1.98	-	V _{pp}
Gain					
LIN/RIN → LOU/ROU	LOVL bit = "0"	-4.5	0	+4.5	dB
	LOVL bit = "1"	-	+2	-	dB
LIN/RIN → HPL/HPR	HPG = 0dB	-4.5	0	+4.5	dB
LIN/RIN → SPLP/SPLN or SPRP/SPRN (Note 33)					
	ALC bit = "0", SPKG2-0 bits = "000"	-0.07	+4.43	+8.93	dB
	ALC bit = "0", SPKG2-0 bits = "001"	-	+6.43	-	dB
	ALC bit = "0", SPKG2-0 bits = "010"	-	+10.65	-	dB
	ALC bit = "0", SPKG2-0 bits = "011"	-	+12.65	-	dB
	ALC bit = "0", SPKG2-0 bits = "100"	-	0	-	dB
	ALC bit = "0", SPKG2-0 bits = "101"	-	-6	-	dB
	ALC bit = "1", SPKG2-0 bits = "000"	-	+6.43	-	dB
	ALC bit = "1", SPKG2-0 bits = "001"	-	+8.43	-	dB
	ALC bit = "1", SPKG2-0 bits = "010"	-	+12.65	-	dB
	ALC bit = "1", SPKG2-0 bits = "011"	-	+14.65	-	dB
	ALC bit = "1", SPKG2-0 bits = "100"	-	+2	-	dB
	ALC bit = "1", SPKG2-0 bits = "101"	-	-4	-	dB
Full-differential Mono Input: IN4+/- pins (L4DIF bit = "1")					
Maximum Input Voltage (Note 31)		-	3.96	-	V _{pp}
Gain					
IN4+/- → LOU/ROU (LODIF bit = "0")	LOVL bit = "0"	-10.5	-6	-1.5	dB
	LOVL bit = "1"	-	-4	-	dB
IN4+/- → LOP/LON (LODIF bit = "1", Note 32)	LOVL bit = "0"	-4.5	0	+4.5	dB
	LOVL bit = "1"	-	+2	-	dB
IN4+/- → HPL/HPR	HPG = 0dB	-10.5	-6	-1.5	dB
IN4+/- → SPLP/SPLN or SPRP/SPRN					
	ALC bit = "0", SPKG2-0 bits = "000"	-6.09	-1.59	+2.91	dB
	ALC bit = "0", SPKG2-0 bits = "001"	-	+0.41	-	dB
	ALC bit = "0", SPKG2-0 bits = "010"	-	+4.63	-	dB
	ALC bit = "0", SPKG2-0 bits = "011"	-	+6.63	-	dB
	ALC bit = "0", SPKG2-0 bits = "100"	-	-6	-	dB
	ALC bit = "0", SPKG2-0 bits = "101"	-	-12	-	dB
	ALC bit = "1", SPKG2-0 bits = "000"	-	+0.41	-	dB
	ALC bit = "1", SPKG2-0 bits = "001"	-	+2.41	-	dB
	ALC bit = "1", SPKG2-0 bits = "010"	-	+6.63	-	dB
	ALC bit = "1", SPKG2-0 bits = "011"	-	+8.63	-	dB
	ALC bit = "1", SPKG2-0 bits = "100"	-	-4	-	dB
	ALC bit = "1", SPKG2-0 bits = "101"	-	-10	-	dB

Note 30. Maximum input voltage is proportional to AVDD voltage. $V_{in} = 0.6 \times AVDD$ (typ.).

Note 31. Maximum input voltage is proportional to AVDD voltage. $V_{in} = (IN4+) - (IN4-) = 1.2 \times AVDD$ (typ.).

The signals with same amplitude and inverted phase should be input to IN4+ and IN4- pins, respectively.

Note 32. $V_{out} = (LOP) - (LON)$ at LODIF bit = "1".

Note 33. Signals with same amplitude and phase are input to LIN and RIN at SPKMN bit = "0". When the input signal is LIN or RIN, these values subtract 6.02dB from the above value.

Parameter	min	typ	max	Units
Power Supplies:				
Power Up (PDN pin = "H")				
All Circuit Power-up:				
AVDD+DVDD+TVDD (Note 34)	-	16.7	25	mA
HVDD: HP-Amp Normal Operation, No Output (Note 35)				
Single-ended Mode (PMHPC bit = "0")	-	3.3	-	mA
Pseudo Cap-less Mode (PMHPC bit = "1")	-	5.2	8	mA
HVDD: SPK-Amp Normal Operation, No Output				
Stereo & High Power Mono SPK Mode (Note 36)	-	14.5	43	mA
Mono SPK Mode (Note 37)	-	7.5	-	mA
Power Down (PDN pin = "L") (Note 38)				
AVDD+DVDD+TVDD+HVDD	-	1	100	μA

Note 34. PLL Master Mode (MCKI=12.288MHz) and PMADL = PMADR = PMDAC = PMSPL=PMSPR=PMLO = PMHPL = PMHPR = PMHPC = PMVCM = PMPLL = MCKO = PMMIN = PMMP = M/S bits = "1". MPWR pin outputs 0mA.

AVDD=12mA(typ.), DVDD=3mA(typ.), TVDD=1.7mA(typ.).

EXT Slave Mode (PMPLL = M/S = MCKO bits = "0"): AVDD=11mA(typ.), DVDD=2.5mA(typ.), TVDD=0.03mA(typ.).

Note 35. PMADL = PMADR = PMDAC = PMLO = PMHPL = PMHPR = PMVCM = PMPLL = PMMIN =HPMTN bits = "1"

Note 36. PMADL = PMADR = PMDAC = PMSPL = PMSPR = PMLO = PMVCM = PMPLL = PMMIN = SPPSN bits = "1"

Note 37. PMADL = PMADR = PMDAC = PMVCM = PMPLL = PMMIN = SPPSN bits = "1", PMSPL bit or PMSPR bit = "1"

Note 38. All digital input pins are held TVDD or VSS3.

■ Power Consumption for each operation mode

Conditions: Ta=25°C; AVDD=DVDD=TVDD=3.3V; HVDD=3.6V, VSS1=VSS2=VSS3=0V; fs=44.1kHz, External Slave Mode, BICK=64fs

Mode	Power Management Bit																AVDD [mA]	DVDD [mA]	TVDD [mA]	HVDD [mA]	Total Power [mW]											
	00H						01H		10H	20H																						
	PMVCM	PMMIN	PMSPL	PMSPR	PMLO	PMDAC	PMADL	PMHPL	PMHPR	PMHPC	PMADR	PMMICL	PMMICR	PMAINL2	PMAINR2	PMAINL3						PMAINR3										
All Power-down	0	0	0	0	0	0	0	0	0	0	0	0	0	0	0	0	0	0	0	0	0	0	0	0	0	0	0					
DAC → Lineout	1	0	0	1	1	1	0	0	0	0	0	0	0	0	0	0	0	0	0	0	0	0	0	0	0	0	0	5.3	1.9	0.03	0.3	24.9
DAC → HP (Note 39)	1	0	0	0	0	1	0	1	1	0	0	0	0	0	0	0	0	0	0	0	0	0	0	0	0	0	0	4.7	1.9	0.03	0.3	33.8
DAC → HP (Note 40)	1	0	0	0	0	1	0	1	1	1	0	0	0	0	0	0	0	0	0	0	0	0	0	0	0	0	0	4.7	1.9	0.03	5.2	40.6
DAC → SPK (Note 41)	1	0	1	0	0	1	0	0	0	0	0	0	0	0	0	0	0	0	0	0	0	0	0	0	0	0	0	4.7	1.9	0.03	7.5	48.9
DAC → SPK (Note 42)	1	0	1	1	0	1	0	0	0	0	0	0	0	0	0	0	0	0	0	0	0	0	0	0	0	0	0	5.1	1.9	0.03	14.5	75.4
LIN2/RIN2 → HP (Note 39)	1	0	0	0	0	0	0	1	1	0	0	0	0	1	1	0	0	0	0	0	0	0	0	0	0	0	0	2.5	0	0	3.3	20.1
LIN2/RIN2 → HP (Note 40)	1	0	0	0	0	0	0	1	1	1	0	0	0	1	1	0	0	0	0	0	0	0	0	0	0	0	0	2.5	0	0	5.2	27.0
LIN2/RIN2 → SPK (Note 41)	1	0	1	0	0	0	0	0	0	0	0	0	0	1	1	0	0	0	0	0	0	0	0	0	0	0	0	2.5	0	0	7.5	35.3
LIN2/RIN2 → SPK (Note 42)	1	0	1	1	0	0	0	0	0	0	0	0	0	1	1	0	0	0	0	0	0	0	0	0	0	0	0	2.9	0	0	14.5	61.8
MIN → Lineout	1	1	0	0	1	0	0	0	0	0	0	0	0	0	0	0	0	0	0	0	0	0	0	0	0	0	0	2.6	0	0	0.3	9.7
LIN2/RIN2 → ADC	1	0	0	0	0	0	1	0	0	0	1	0	0	0	0	0	0	0	0	0	0	0	0	0	0	0	0	6.4	1.6	0.03	0.3	27.6
LIN1 (Mono) → ADC	1	0	0	0	0	0	1	0	0	0	0	0	0	0	0	0	0	0	0	0	0	0	0	0	0	0	0	4.2	1.4	0.03	0.3	19.7
LIN2/RIN2 → ADC &DAC→HP(Note 39)	1	0	0	0	0	1	1	1	1	0	1	0	0	0	0	0	0	0	0	0	0	0	0	0	0	0	0	9.4	3.1	0.03	3.3	53.2
LIN2/RIN2 → ADC &DAC→HP(Note 40)	1	0	0	0	0	1	1	1	1	1	1	0	0	0	0	0	0	0	0	0	0	0	0	0	0	0	0	9.4	3.1	0.03	5.2	60.1

Note 39. Single-ended Mode

Note 40. Pseudo Cap-less Mode

Note 41. Mono SPK (In case of using Lch SPK-Amp. When Rch SPK-Amp is used, PMSPL bit is “0” and PMSPR bit is “1”.)

Note 42. Stereo SPK Mode or High Power Mono SPK Mode

Table 1. Power Consumption for each operation mode (typ.)

FILTER CHARACTERISTICS

(Ta=25°C; AVDD, DVDD=2.6 ~ 3.6V; TVDD=1.6 ~ 3.6V; HVDD=2.6 ~ 5.0V; fs=44.1kHz; DEM=OFF; FIL1=FIL3=EQ=FBEQ=OFF)

Parameter		Symbol	min	typ	max	Units
ADC Digital Filter (Decimation LPF):						
Passband (Note 43)	±0.16dB	PB	0	-	17.3	kHz
	-0.66dB		-	19.4	-	kHz
	-1.1dB		-	19.9	-	kHz
	-6.9dB		-	22.1	-	kHz
Stopband		SB	26.1	-	-	kHz
Passband Ripple		PR	-	-	±0.1	dB
Stopband Attenuation		SA	73	-	-	dB
Group Delay (Note 44)		GD	-	19	-	1/fs
Group Delay Distortion		ΔGD	-	0	-	μs
ADC Digital Filter (HPF): (Note 45)						
Frequency Response (Note 43)	-3.0dB	FR	-	0.9	-	Hz
	-0.5dB		-	2.7	-	Hz
	-0.1dB		-	6.0	-	Hz
DAC Digital Filter (LPF):						
Passband (Note 43)	±0.1dB	PB	0	-	19.6	kHz
	-0.7dB		-	20.0	-	kHz
	-6.0dB		-	22.05	-	kHz
Stopband		SB	25.2	-	-	kHz
Passband Ripple		PR	-	-	±0.01	dB
Stopband Attenuation		SA	59	-	-	dB
Group Delay (Note 44)		GD	-	26	-	1/fs
DAC Digital Filter (LPF) + SCF:						
Frequency Response: 0 ~ 20.0kHz		FR	-	±1.0	-	dB
DAC Digital Filter (HPF): (Note 45)						
Frequency Response (Note 43)	-3.0dB	FR	-	0.9	-	Hz
	-0.5dB		-	2.7	-	Hz
	-0.1dB		-	6.0	-	Hz

Note 43. The passband and stopband frequencies with fs (system sampling rate).

For example, DAC is PB=0.454*fs (@-0.7dB). Each response refers to that of 1kHz.

Note 44. The calculated delay time caused by digital filtering. This time is from the input of analog signal to setting of the 16-bit data of both channels from the input register to the output register of the ADC. This time includes the group delay of the HPF. For the DAC, this time is from setting the 16-bit data of both channels from the input register to the output of analog signal. Group delay of DAC part is 25/fs(typ.) at PMADL=PMADR bits = "0".

Note 45. When PMADL bit = "1" or PMADR bit = "1", the HPF of ADC is enabled but the HPF of DAC is disabled. When PMADL=PMADR bits = "0", PMDAC bit = "1", the HPF of DAC is enabled but the HPF of ADC is disabled.

DC CHARACTERISTICS

(Ta=25°C; AVDD, DVDD=2.6 ~ 3.6V; TVDD=1.6 ~ 3.6V; HVDD=2.6 ~ 5.0V)

Parameter	Symbol	min	typ	max	Units
High-Level Input Voltage	$2.2V \leq TVDD \leq 3.6V$	V _{IH}	70%TVDD	-	V
	$1.6V \leq TVDD < 2.2V$	V _{IH}	80%TVDD	-	V
Low-Level Input Voltage	$2.2V \leq TVDD \leq 3.6V$	V _{IL}	-	30%TVDD	V
	$1.6V \leq TVDD < 2.2V$	V _{IL}	-	20%TVDD	V
High-Level Output Voltage (I _{out} =-200μA)	VOH	TVDD-0.2	-	-	V
Low-Level Output Voltage (Except SDA pin: I _{out} =200μA) (SDA pin, 2.0V≤TVDD≤3.6V: I _{out} =3mA) (SDA pin, 1.6V≤TVDD<2.0V: I _{out} =3mA)	VOL	-	-	0.2	V
	VOL	-	-	0.4	V
	VOL	-	-	20%TVDD	V
	VOL	-	-	20%TVDD	V
Input Leakage Current	I _{in}	-	-	±10	μA

SWITCHING CHARACTERISTICS

 (Ta=25°C; AVDD, DVDD=2.6 ~ 3.6V; TVDD=1.6 ~ 3.6V; HVDD=2.6 ~ 5.0V; C_L=20pF; unless otherwise specified)

Parameter	Symbol	min	typ	max	Units
PLL Master Mode (PLL Reference Clock = MCKI pin)					
MCKI Input Timing					
Frequency	fCLK	11.2896	-	27	MHz
Pulse Width Low	tCLKL	0.4/fCLK	-	-	ns
Pulse Width High	tCLKH	0.4/fCLK	-	-	ns
MCKO Output Timing					
Frequency	fMCK	0.2352	-	12.288	MHz
Duty Cycle	Except 256fs at fs=32kHz, 29.4kHz	dMCK	40	50	%
	256fs at fs=32kHz, 29.4kHz	dMCK	-	33	%
LRCK Output Timing					
Frequency	fs	7.35	-	48	kHz
DSP Mode: Pulse Width High	tLRCKH	-	tBCK	-	ns
Except DSP Mode: Duty Cycle	Duty	-	50	-	%
BICK Output Timing					
Period	BCKO bit = "0"	tBCK	-	1/(32fs)	ns
	BCKO bit = "1"	tBCK	-	1/(64fs)	ns
Duty Cycle	dBCK	-	50	-	%
PLL Slave Mode (PLL Reference Clock = MCKI pin)					
MCKI Input Timing					
Frequency	fCLK	11.2896	-	27	MHz
Pulse Width Low	tCLKL	0.4/fCLK	-	-	ns
Pulse Width High	tCLKH	0.4/fCLK	-	-	ns
MCKO Output Timing					
Frequency	fMCK	0.2352	-	12.288	MHz
Duty Cycle	Except 256fs at fs=32kHz, 29.4kHz	dMCK	40	50	%
	256fs at fs=32kHz, 29.4kHz	dMCK	-	33	%
LRCK Input Timing					
Frequency	fs	7.35	-	48	kHz
DSP Mode: Pulse Width High	tLRCKH	tBCK-60	-	1/fs - tBCK	ns
Except DSP Mode: Duty Cycle	Duty	45	-	55	%
BICK Input Timing					
Period	tBCK	1/(64fs)	-	1/(32fs)	ns
Pulse Width Low	tBCKL	0.4 x tBCK	-	-	ns
Pulse Width High	tBCKH	0.4 x tBCK	-	-	ns

Parameter	Symbol	min	typ	max	Units
PLL Slave Mode (PLL Reference Clock = LRCK pin)					
LRCK Input Timing					
Frequency	fs	7.35	-	48	kHz
DSP Mode: Pulse Width High	tLRCKH	tBCK-60	-	1/fs - tBCK	ns
Except DSP Mode: Duty Cycle	Duty	45	-	55	%
BICK Input Timing					
Period	tBCK	1/(64fs)	-	1/(32fs)	ns
Pulse Width Low	tBCKL	130	-	-	ns
Pulse Width High	tBCKH	130	-	-	ns
PLL Slave Mode (PLL Reference Clock = BICK pin)					
LRCK Input Timing					
Frequency	fs	7.35	-	48	kHz
DSP Mode: Pulse Width High	tLRCKH	tBCK-60	-	1/fs - tBCK	ns
Except DSP Mode: Duty Cycle	Duty	45	-	55	%
BICK Input Timing					
Period	PLL3-0 bits = "0010"	tBCK	-	1/(32fs)	ns
	PLL3-0 bits = "0011"	tBCK	-	1/(64fs)	ns
Pulse Width Low		tBCKL	0.4 x tBCK	-	ns
Pulse Width High		tBCKH	0.4 x tBCK	-	ns
External Slave Mode					
MCKI Input Timing					
Frequency	256fs	fCLK	1.8816	-	12.288 MHz
	512fs	fCLK	3.7632	-	13.312 MHz
	1024fs	fCLK	7.5264	-	13.312 MHz
Pulse Width Low		tCLKL	0.4/fCLK	-	ns
Pulse Width High		tCLKH	0.4/fCLK	-	ns
LRCK Input Timing					
Frequency	256fs	fs	7.35	-	48 kHz
	512fs	fs	7.35	-	26 kHz
	1024fs	fs	7.35	-	13 kHz
DSP Mode: Pulse Width High		tLRCKH	tBCK-60	-	1/fs - tBCK ns
Except DSP Mode: Duty Cycle		Duty	45	-	55 %
BICK Input Timing					
Period		tBCK	312.5	-	ns
Pulse Width Low		tBCKL	130	-	ns
Pulse Width High		tBCKH	130	-	ns
External Master Mode					
MCKI Input Timing					
Frequency	256fs	fCLK	1.8816	-	12.288 MHz
	512fs	fCLK	3.7632	-	13.312 MHz
	1024fs	fCLK	7.5264	-	13.312 MHz
Pulse Width Low		tCLKL	0.4/fCLK	-	ns
Pulse Width High		tCLKH	0.4/fCLK	-	ns
LRCK Output Timing					
Frequency		fs	7.35	-	48 kHz
DSP Mode: Pulse Width High		tLRCKH	-	tBCK	ns
Except DSP Mode: Duty Cycle		Duty	-	50	%
BICK Output Timing					
Period	BCKO bit = "0"	tBCK	-	1/(32fs)	ns
	BCKO bit = "1"	tBCK	-	1/(64fs)	ns
Duty Cycle		dBCK	-	50	%

Parameter	Symbol	min	typ	max	Units
Audio Interface Timing (DSP Mode)					
Master Mode					
LRCK “↑” to BICK “↑” (Note 46)	tDBF	0.5 x tBCK – 40	0.5 x tBCK	0.5 x tBCK + 40	ns
LRCK “↑” to BICK “↓” (Note 47)	tDBF	0.5 x tBCK – 40	0.5 x tBCK	0.5 x tBCK + 40	ns
BICK “↑” to SDTO (BCKP bit = “0”)	tBSD	–70	-	70	ns
BICK “↓” to SDTO (BCKP bit = “1”)	tBSD	–70	-	70	ns
SDTI Hold Time	tSDH	50	-	-	ns
SDTI Setup Time	tSDS	50	-	-	ns
Slave Mode					
LRCK “↑” to BICK “↑” (Note 46)	tLRB	0.4 x tBCK	-	-	ns
LRCK “↑” to BICK “↓” (Note 47)	tLRB	0.4 x tBCK	-	-	ns
BICK “↑” to LRCK “↑” (Note 46)	tBLR	0.4 x tBCK	-	-	ns
BICK “↓” to LRCK “↑” (Note 47)	tBLR	0.4 x tBCK	-	-	ns
BICK “↑” to SDTO (BCKP bit = “0”)	tBSD	-	-	80	ns
BICK “↓” to SDTO (BCKP bit = “1”)	tBSD	-	-	80	ns
SDTI Hold Time	tSDH	50	-	-	ns
SDTI Setup Time	tSDS	50	-	-	ns
Audio Interface Timing (Right/Left justified & I²S)					
Master Mode					
BICK “↓” to LRCK Edge (Note 48)	tMBLR	–40	-	40	ns
LRCK Edge to SDTO (MSB) (Except I ² S mode)	tLRD	–70	-	70	ns
BICK “↓” to SDTO	tBSD	–70	-	70	ns
SDTI Hold Time	tSDH	50	-	-	ns
SDTI Setup Time	tSDS	50	-	-	ns
Slave Mode					
LRCK Edge to BICK “↑” (Note 48)	tLRB	50	-	-	ns
BICK “↑” to LRCK Edge (Note 48)	tBLR	50	-	-	ns
LRCK Edge to SDTO (MSB) (Except I ² S mode)	tLRD	-	-	80	ns
BICK “↓” to SDTO	tBSD	-	-	80	ns
SDTI Hold Time	tSDH	50	-	-	ns
SDTI Setup Time	tSDS	50	-	-	ns

Note 46. MSBS, BCKP bits = “00” or “11”.

Note 47. MSBS, BCKP bits = “01” or “10”.

Note 48. BICK rising edge must not occur at the same time as LRCK edge.

Parameter	Symbol	min	typ	max	Units
Control Interface Timing (I²C Bus):					
SCL Clock Frequency	fSCL	-	-	400	kHz
Bus Free Time Between Transmissions	tBUF	1.3	-	-	μs
Start Condition Hold Time (prior to first clock pulse)	tHD:STA	0.6	-	-	μs
Clock Low Time	tLOW	1.3	-	-	μs
Clock High Time	tHIGH	0.6	-	-	μs
Setup Time for Repeated Start Condition	tSU:STA	0.6	-	-	μs
SDA Hold Time from SCL Falling (Note 50)	tHD:DAT	0	-	-	μs
SDA Setup Time from SCL Rising	tSU:DAT	0.1	-	-	μs
Rise Time of Both SDA and SCL Lines	tR	-	-	0.3	μs
Fall Time of Both SDA and SCL Lines	tF	-	-	0.3	μs
Setup Time for Stop Condition	tSU:STO	0.6	-	-	μs
Capacitive Load on Bus	Cb	-	-	400	pF
Pulse Width of Spike Noise Suppressed by Input Filter	tSP	0	-	50	ns
Power-down & Reset Timing					
PDN Pulse Width (Note 51)	tPD	150	-	-	ns
PMADL or PMADR “↑” to SDTO valid (Note 52)	tPDV	-	1059	-	1/fs

Note 49. I²C is a registered trademark of Philips Semiconductors.

Note 50. Data must be held long enough to bridge the 300ns-transition time of SCL.

Note 51. AK4648 can be reset by the PDN pin = “L”.

Note 52. This is the count of LRCK “↑” from the PMADL or PMADR bit = “1”.

■ Timing Diagram

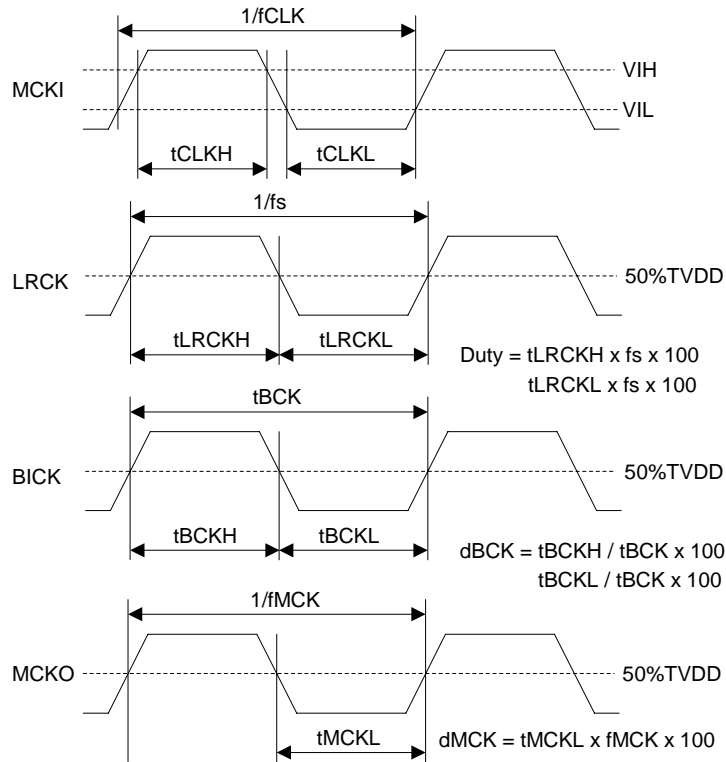

Note 53. MCKO is not available at EXT Master mode.

Figure 4. Clock Timing (PLL/EXT Master mode)

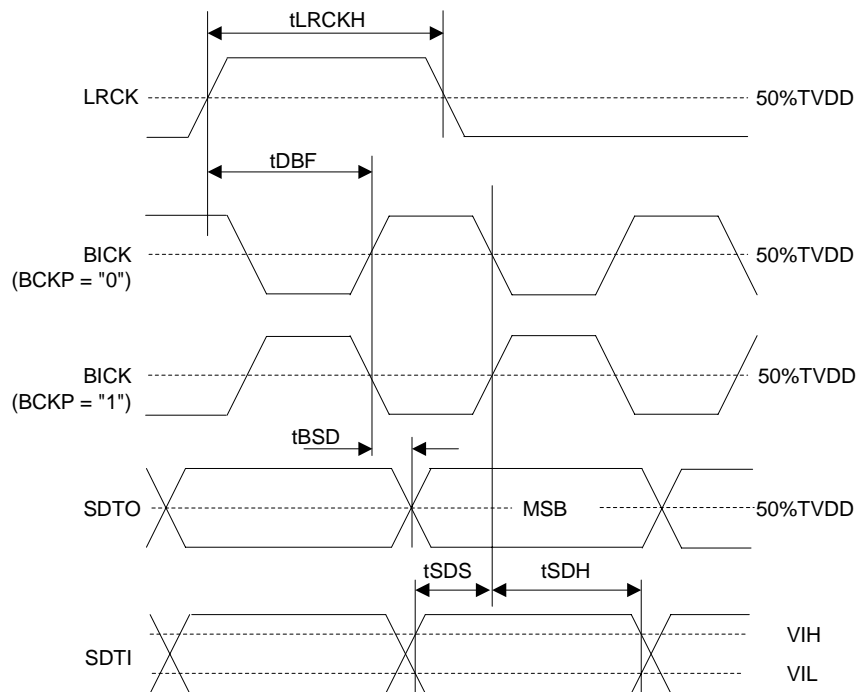

Figure 5. Audio Interface Timing (PLL/EXT Master mode, DSP mode, MSBS bit = "0")

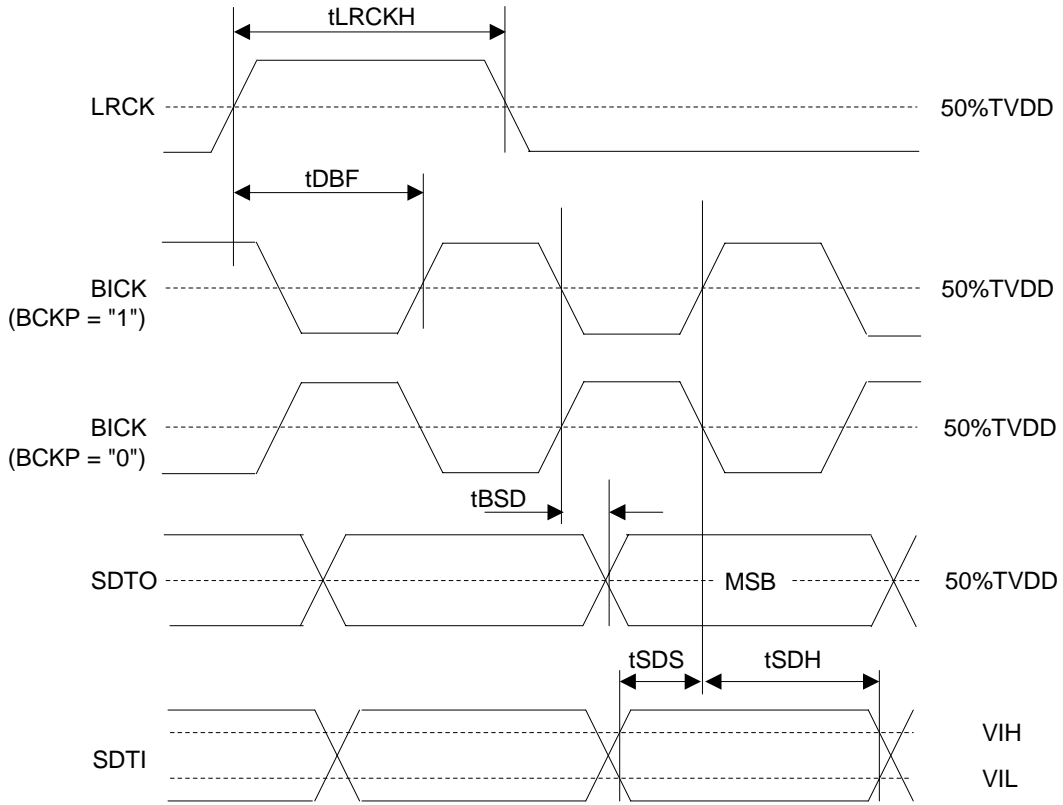

Figure 6. Audio Interface Timing (PLL/EXT Master mode, DSP mode, MSBS bit = "1")

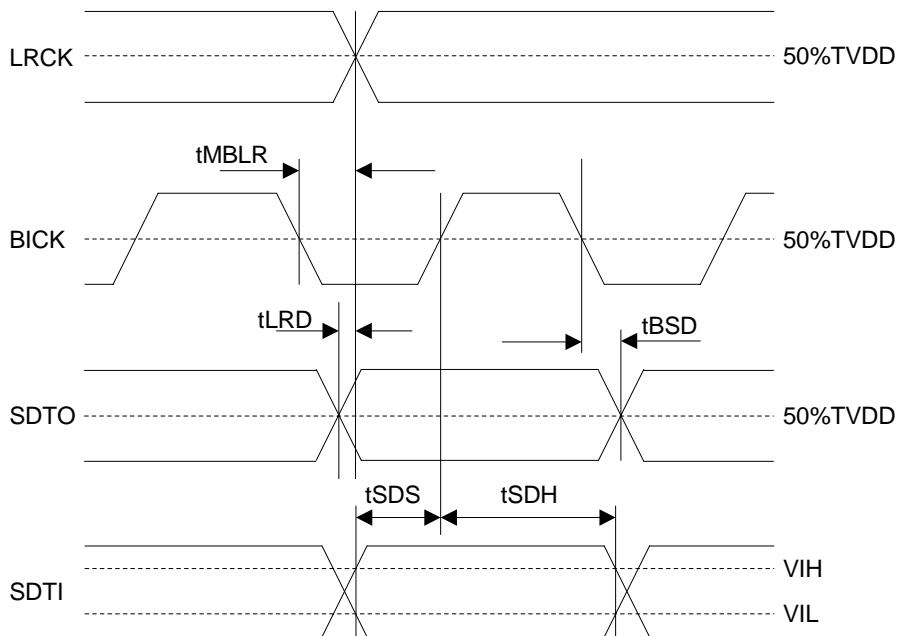

Figure 7. Audio Interface Timing (PLL/EXT Master mode, Except DSP mode)

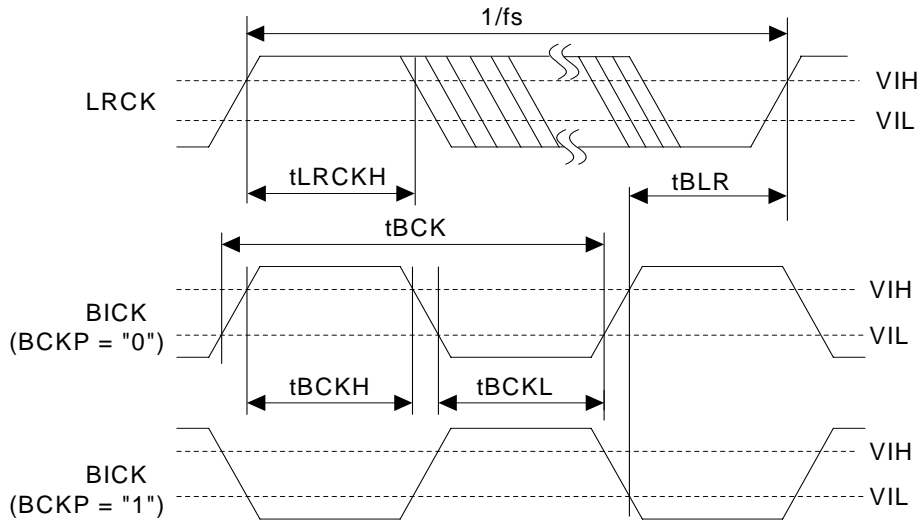

Figure 8. Clock Timing (PLL Slave mode; PLL Reference Clock = LRCK or BICK pin, DSP mode, MSBS bit = "0")

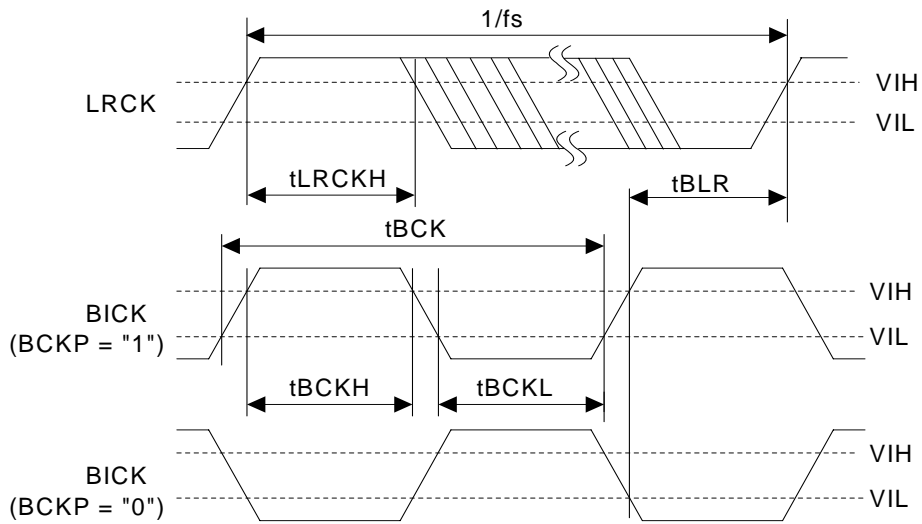

Figure 9. Clock Timing (PLL Slave mode; PLL Reference Clock = LRCK or BICK pin, DSP mode, MSBS bit = "1")

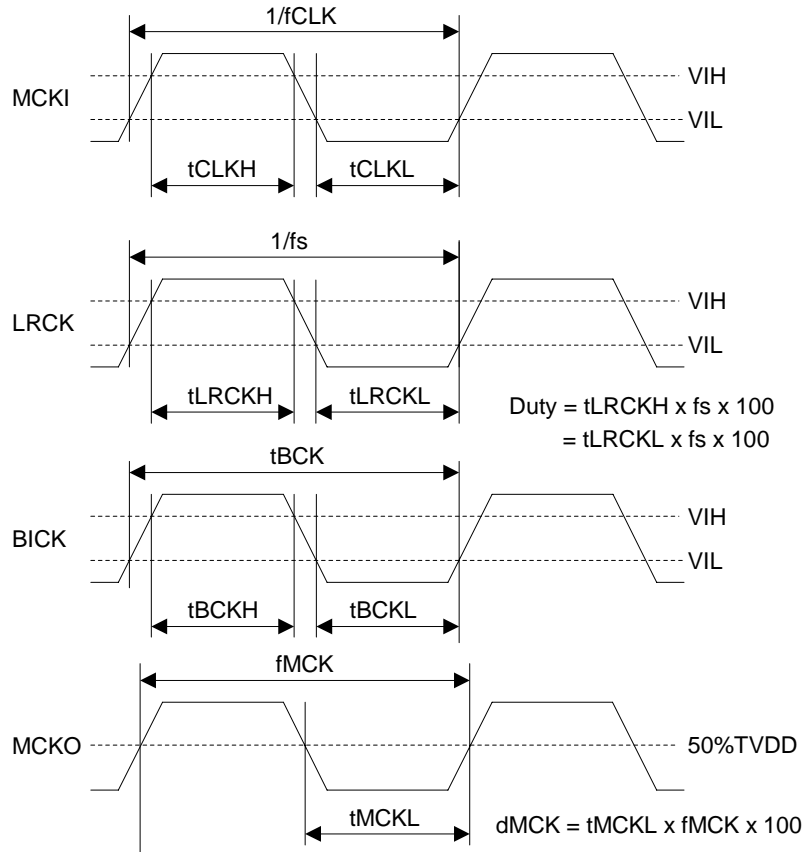

Figure 10. Clock Timing (PLL Slave mode; PLL Reference Clock = MCKI pin, Except DSP mode)

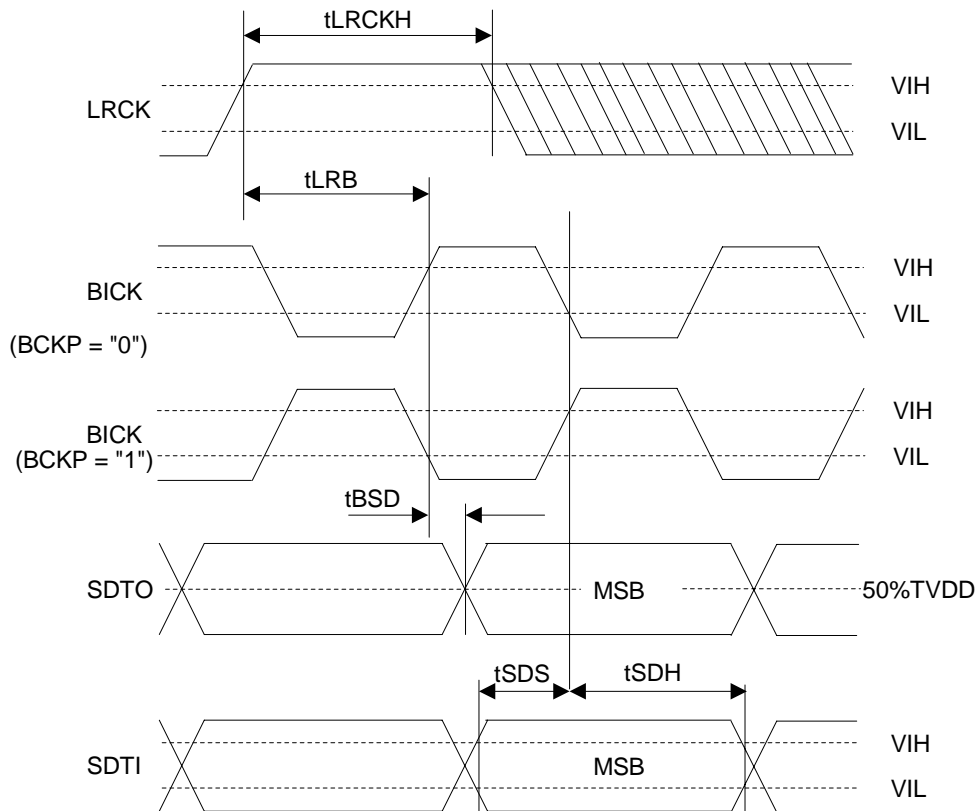

Figure 11. Audio Interface Timing (PLL Slave mode, DSP mode; MSBS bit = "0")

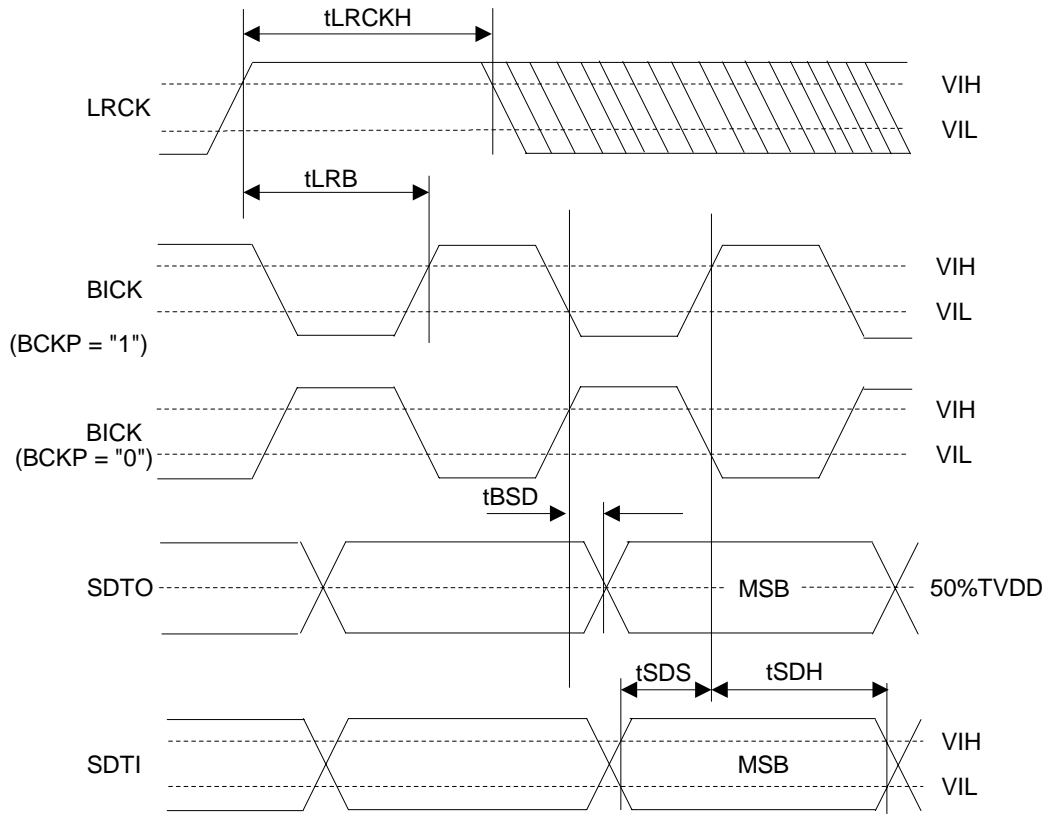

Figure 12. Audio Interface Timing (PLL Slave mode, DSP mode, MSBS bit = "1")

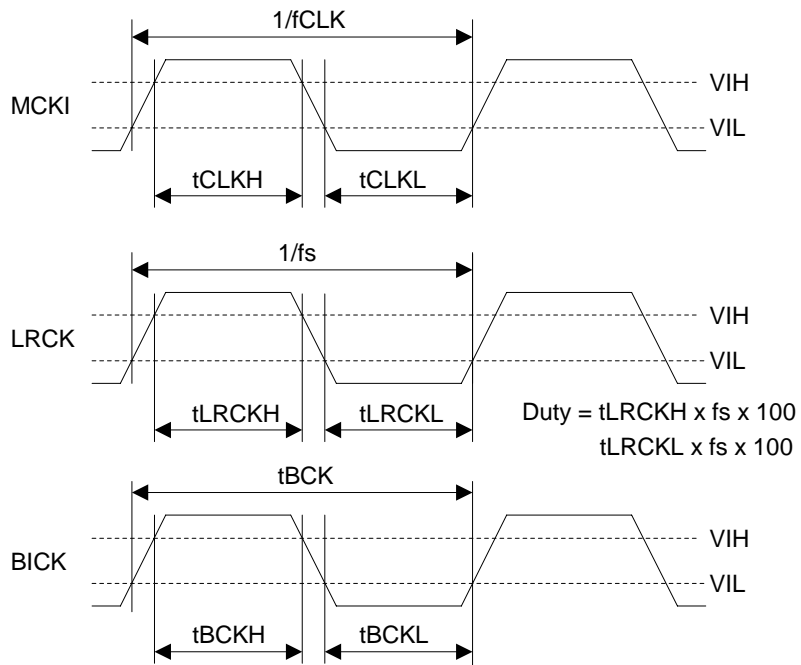

Figure 13. Clock Timing (EXT Slave mode)

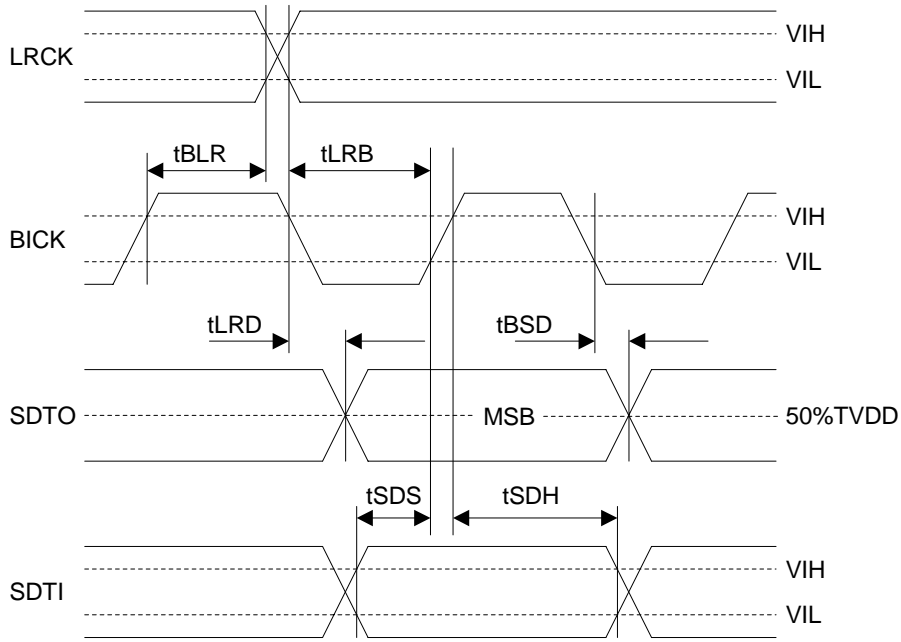

Figure 14. Audio Interface Timing (PLL/EXT Slave mode, Except DSP mode)

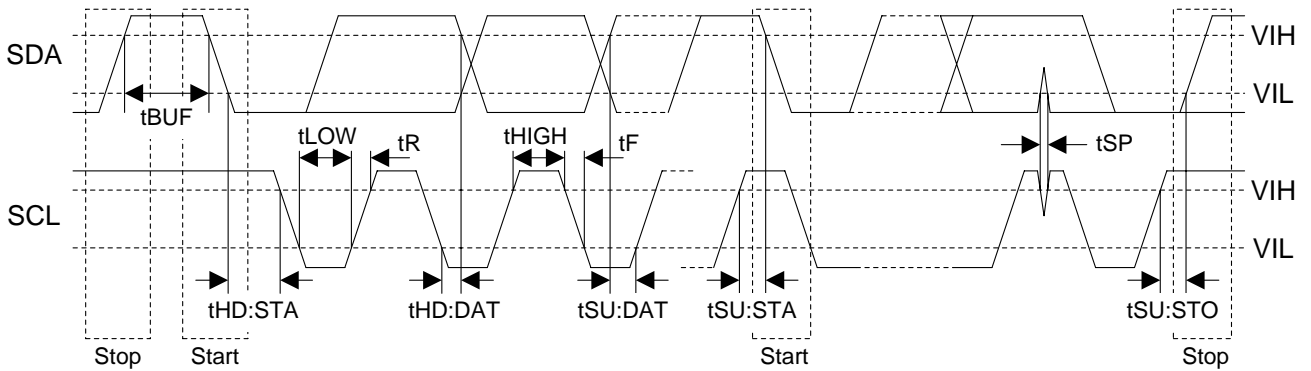

Figure 15. I²C Bus Mode Timing

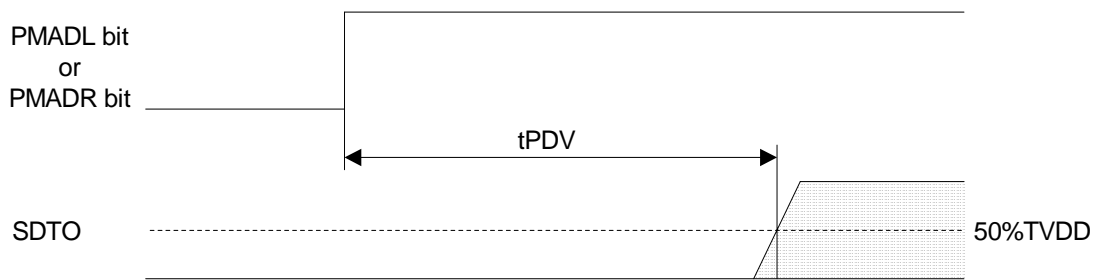

Figure 16. Power Down & Reset Timing 1

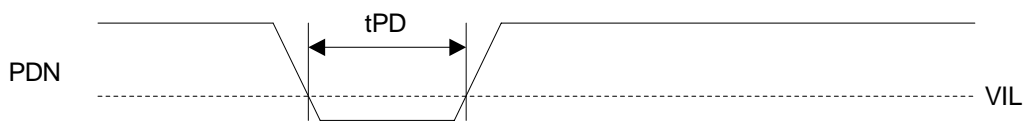

Figure 17. Power Down & Reset Timing 2

OPERATION OVERVIEW

■ System Clock

There are the following five clock modes to interface with external devices. (Table 2 and Table 3.)

Mode	PMPLL bit	M/S bit	PLL3-0 bits	Figure
PLL Master Mode (Note 54)	1	1	Table 5	Figure 18
PLL Slave Mode 1 (PLL Reference Clock: MCKI pin)	1	0	Table 5	Figure 19
PLL Slave Mode 2 (PLL Reference Clock: LRCK or BICK pin)	1	0	Table 5	Figure 20 Figure 21
EXT Slave Mode	0	0	x	Figure 22
EXT Master Mode	0	1	x	Figure 23

Note 54. If M/S bit = "1", PMPLL bit = "0" and MCKO bit = "1" during the setting of PLL Master Mode, the invalid clocks are output from MCKO pin when MCKO bit is "1".

Table 2. Clock Mode Setting (x: Don't care)

Mode	MCKO bit	MCKO pin	MCKI pin	BICK pin	LRCK pin
PLL Master Mode	0	"L"	Selected by PLL3-0 bits	Output (Selected by BCKO bit)	Output (1fs)
	1	Selected by PS1-0 bits			
PLL Slave Mode (PLL Reference Clock: MCKI pin)	0	"L"	Selected by PLL3-0 bits	Input (≥ 32fs)	Input (1fs)
	1	Selected by PS1-0 bits			
PLL Slave Mode (PLL Reference Clock: LRCK or BICK pin)	0	"L"	GND	Input (Selected by PLL3-0 bits)	Input (1fs)
EXT Slave Mode	0	"L"	Selected by FS1-0 bits	Input (≥ 32fs)	Input (1fs)
EXT Master Mode	0	"L"	Selected by FS1-0 bits	Output (Selected by BCKO bit)	Output (1fs)

Table 3. Clock pins state in Clock Mode

■ Master Mode/Slave Mode

The M/S bit selects either master or slave mode. M/S bit = "1" selects master mode and "0" selects slave mode. When the AK4648 is power-down mode (PDN pin = "L") and exits reset state, the AK4648 is slave mode. After exiting reset state, the AK4648 goes to master mode by changing M/S bit = "1".

When the AK4648 is used by master mode, LRCK and BICK pins are a floating state until M/S bit becomes "1". LRCK and BICK pins of the AK4648 should be pulled-down or pulled-up by the resistor (about 100kΩ) externally to avoid the floating state.

M/S bit	Mode
0	Slave Mode
1	Master Mode

(default)

Table 4. Select Master/Slave Mode

■ PLL Mode (AIN3 bit = “0”, PMPLL bit = “1”)

When PMPLL bit is “1”, a fully integrated analog phase locked loop (PLL) generates a clock that is selected by the PLL3-0 and FS3-0 bits. The PLL lock time is shown in Table 5, whenever the AK4648 is supplied to stable clocks after PLL is powered-up (PMPLL bit = “0” → “1”) or sampling frequency changes. When AIN3 bit = “1”, the PLL is not available.

1) Setting of PLL Mode

Mode	PLL3 bit	PLL2 bit	PLL1 bit	PLL0 bit	PLL Reference Clock Input Pin	Input Frequency	R and C of VCOC pin		PLL Lock Time (max)
							R[Ω]	C[F]	
0	0	0	0	0	LRCK pin	1fs	6.8k	220n	160ms (default)
1	0	0	0	1	N/A	-	-	-	-
2	0	0	1	0	BICK pin	32fs	10k	4.7n	2ms
							10k	10n	4ms
3	0	0	1	1	BICK pin	64fs	10k	4.7n	2ms
							10k	10n	4ms
4	0	1	0	0	MCKI pin	11.2896MHz	10k	4.7n	40ms
5	0	1	0	1	MCKI pin	12.288MHz	10k	4.7n	40ms
6	0	1	1	0	MCKI pin	12MHz	10k	4.7n	40ms
7	0	1	1	1	MCKI pin	24MHz	10k	4.7n	40ms
8	1	0	0	0	MCKI pin	19.2MHz	10k	4.7n	40ms
12	1	1	0	0	MCKI pin	13.5MHz	10k	10n	40ms
13	1	1	0	1	MCKI pin	27MHz	10k	10n	40ms
14	1	1	1	0	MCKI pin	13MHz	10k	220n	60ms
15	1	1	1	1	MCKI pin	26MHz	10k	220n	60ms
Others	Others			N/A					

Table 5. Setting of PLL Mode (*fs: Sampling Frequency)

2) Setting of sampling frequency in PLL Mode

When PLL reference clock input is MCKI pin, the sampling frequency is selected by FS3-0 bits as defined in Table 6.

Mode	FS3 bit	FS2 bit	FS1 bit	FS0 bit	Sampling Frequency
0	0	0	0	0	8kHz (default)
1	0	0	0	1	12kHz
2	0	0	1	0	16kHz
3	0	0	1	1	24kHz
4	0	1	0	0	7.35kHz
5	0	1	0	1	11.025kHz
6	0	1	1	0	14.7kHz
7	0	1	1	1	22.05kHz
10	1	0	1	0	32kHz
11	1	0	1	1	48kHz
14	1	1	1	0	29.4kHz
15	1	1	1	1	44.1kHz
Others	Others				N/A

Table 6. Setting of Sampling Frequency at PMPLL bit = “1” (Reference Clock = MCKI pin)

When PLL reference clock input is LRCK or BICK pin, the sampling frequency is selected by FS3 and FS1-0 bits. (Table 7). **FS2 bit is “don’t care”.**

Mode	FS3 bit	FS2 bit	FS1 bit	FS0 bit	Sampling Frequency Range
0	0	x	0	0	7.35kHz ≤ fs ≤ 8kHz
1	0	x	0	1	8kHz < fs ≤ 12kHz
2	0	x	1	0	12kHz < fs ≤ 16kHz
3	0	x	1	1	16kHz < fs ≤ 24kHz
6	1	x	1	0	24kHz < fs ≤ 32kHz
7	1	x	1	1	32kHz < fs ≤ 48kHz
Others	Others				N/A

(x: Don’t care)

Table 7. Setting of Sampling Frequency at PMPLL bit = “1” (Reference Clock = LRCK or BICK pin)

■ PLL Unlock State

1) PLL Master Mode (AIN3 bit = “0”; PMPLL bit = “1”, M/S bit = “1”)

In this mode, LRCK and BICK pins go to “L” and irregular frequency clock is output from MCKO pins at MCKO bit is “1” before the PLL goes to lock state after PMPLL bit = “0” → “1”. If MCKO bit is “0”, MCKO pin goes to “L” (Table 8).

After the PLL is locked, the first period of LRCK and BICK may be invalid clock, but these clocks return to normal state after a period of 1/fs.

When sampling frequency is changed, BICK and LRCK pins do not output irregular frequency clocks but go to “L” by setting PMPLL bit to “0”.

PLL State	MCKO pin		BICK pin	LRCK pin
	MCKO bit = “0”	MCKO bit = “1”		
After that PMPLL bit “0” → “1”	“L” Output	Invalid	“L” Output	“L” Output
PLL Unlock (except case above)	“L” Output	Invalid	Invalid	Invalid
PLL Lock	“L” Output	Table 10	Table 11	1fs Output

Table 8. Clock Operation at PLL Master Mode (PMPLL bit = “1”, M/S bit = “1”)

2) PLL Slave Mode (AIN3 bit = “0”, PMPLL bit = “1”, M/S bit = “0”)

In this mode, an invalid clock is output from MCKO pin before the PLL goes to lock state after PMPLL bit = “0” → “1”. Then, the clock selected by Table 10 is output from MCKO pin when PLL is locked. ADC and DAC output invalid data when the PLL is unlocked. For DAC, the output signal should be muted by writing “0” to DACL and DACH bits.

PLL State	MCKO pin	
	MCKO bit = “0”	MCKO bit = “1”
Just after PMPLL bit “0” → “1”	“L” Output	Invalid
PLL Unlock (except case above)	“L” Output	Invalid
PLL Lock	“L” Output	Output

Table 9. Clock Operation at PLL Slave Mode (PMPLL bit = “0”, M/S bit = “0”)

■ **PLL Master Mode (AIN3 bit = “0”, PMPLL bit = “1”, M/S bit = “1”)**

When an external clock (11.2896MHz, 12MHz, 12.288MHz, 13MHz, 13.5MHz, 19.2MHz, 24MHz, 26MHz or 27MHz) is input to MCKI pin, the MCKO, BICK and LRCK clocks are generated by an internal PLL circuit. The MCKO output frequency is selected by PS1-0 bits (Table 10) and the output is enabled by MCKO bit. The BICK output frequency is selected between 32fs or 64fs, by BCKO bit (Table 11).

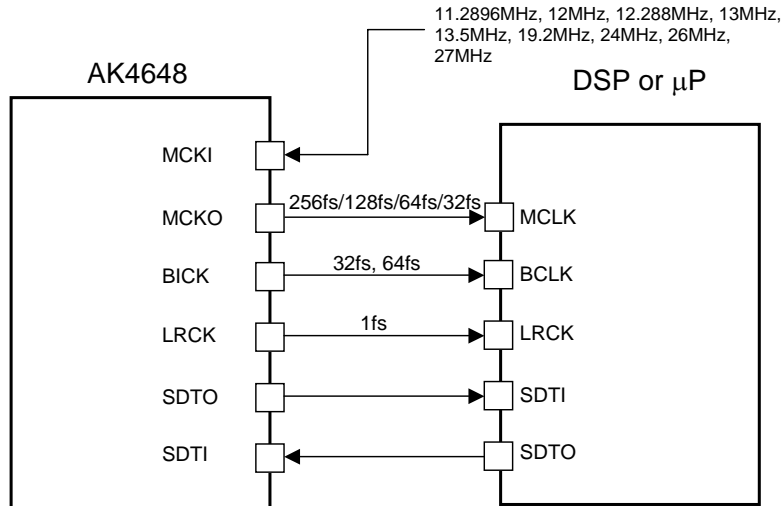

Figure 18. PLL Master Mode

Mode	PS1 bit	PS0 bit	MCKO pin
0	0	0	256fs
1	0	1	128fs
2	1	0	64fs
3	1	1	32fs

(default)

Table 10. MCKO Output Frequency (PLL Mode, MCKO bit = “1”)

BCKO bit	BICK Output Frequency
0	32fs
1	64fs

(default)

Table 11. BICK Output Frequency at Master Mode

■ **PLL Slave Mode (AIN3 bit = “0”, PMPLL bit = “1”, M/S bit = “0”)**

A reference clock of PLL is selected among the input clocks to MCKI, BICK or LRCK pin. The required clock to the AK4648 is generated by an internal PLL circuit. Input frequency is selected by PLL3-0 bits (Table 5).

a) PLL reference clock: MCKI pin

BICK and LRCK inputs should be synchronized with MCKO output. The phase between MCKO and LRCK dose not matter. MCKO pin outputs the frequency selected by PS1-0 bits (Table 10) and the output is enabled by MCKO bit. Sampling frequency can be selected by FS3-0 bits (Table 6).

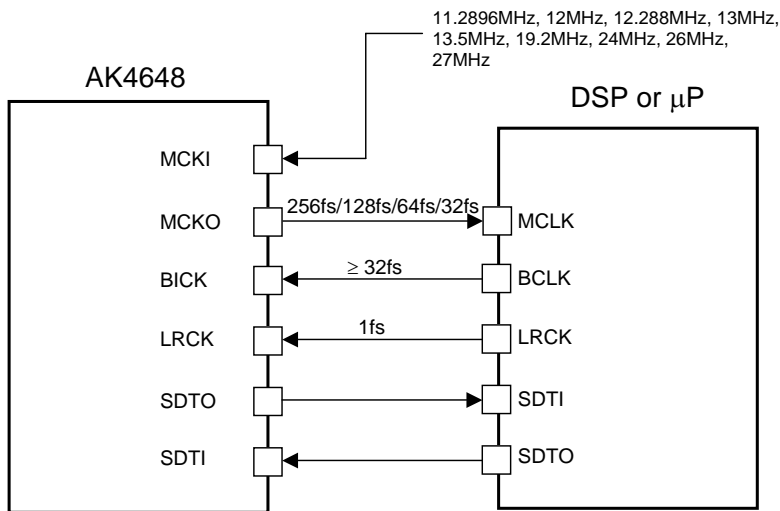

Figure 19. PLL Slave Mode 1 (PLL Reference Clock: MCKI pin)

b) PLL reference clock: BICK or LRCK pin

Sampling frequency corresponds to 7.35kHz to 48kHz by changing FS3-0 bits ((x: Don't care) Table 7).

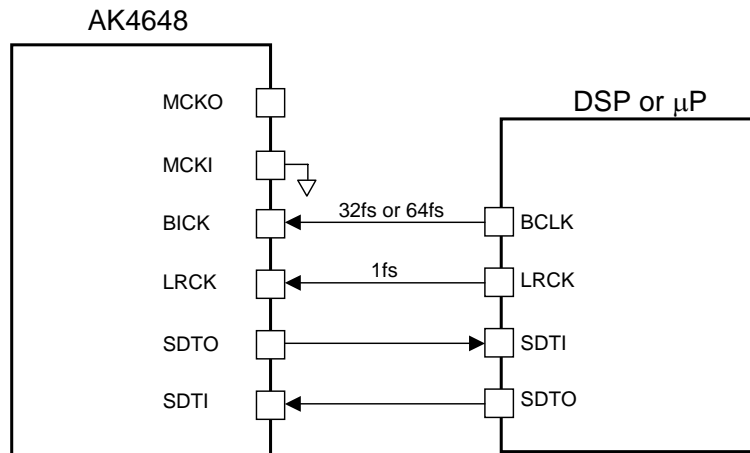

Figure 20. PLL Slave Mode 2 (PLL Reference Clock: BICK pin)

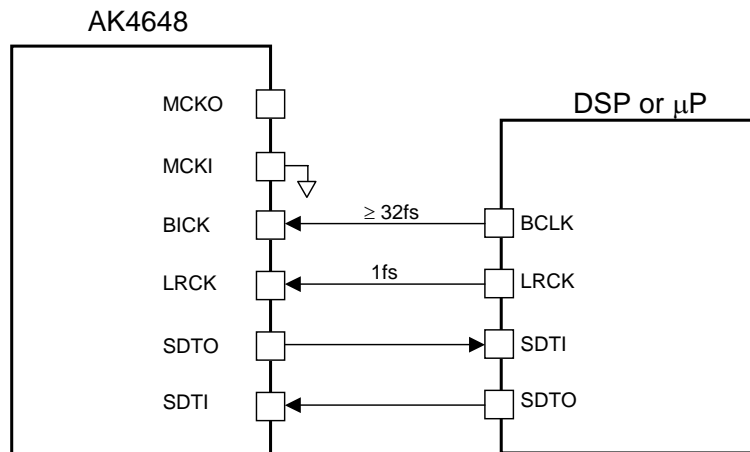

Figure 21. PLL Slave Mode 2 (PLL Reference Clock: LRCK pin)

The external clocks (MCKI, BICK and LRCK) should always be present whenever the ADC or DAC is in operation (PMADL bit = "1", PMADR bit = "1" or PMDAC bit = "1"). If these clocks are not provided, the AK4648 may draw excess current and it is not possible to operate properly because utilizes dynamic refreshed logic internally. If the external clocks are not present, the ADC and DAC should be in the power-down mode (PMADL=PMADR=PMDAC bits = "0").

■ EXT Slave Mode (PMPLL bit = “0”, M/S bit = “0”)

When PMPLL bit is “0”, the AK4648 becomes EXT mode. Master clock is input from MCKI pin, the internal PLL circuit is not operated. This mode is compatible with I/F of the normal audio CODEC. The clocks required to operate are MCKI (256fs, 512fs or 1024fs), LRCK (fs) and BICK ($\geq 32fs$). The master clock (MCKI) should be synchronized with LRCK. The phase between these clocks does not matter. The input frequency of MCKI is selected by FS1-0 bits ((x: Don't care) Table 12).

Mode	FS3-2 bits	FS1 bit	FS0 bit	MCKI Input Frequency	Sampling Frequency Range
0	x	0	0	256fs	7.35kHz ~ 48kHz
1	x	0	1	1024fs	7.35kHz ~ 13kHz
2	x	1	0	256fs	7.35kHz ~ 48kHz
3	x	1	1	512fs	7.35kHz ~ 26kHz

(x: Don't care)

Table 12. MCKI Frequency at EXT Slave Mode (PMPLL bit = “0”, M/S bit = “0”)

The S/N of the DAC at low sampling frequencies is worse than at high sampling frequencies due to out-of-band noise. The out-of-band noise can be improved by using higher frequency of the master clock. The S/N of the DAC output through LOUT/ROUT pins at fs=8kHz is shown in Table 13.

MCKI	S/N (fs=8kHz, 20kHzLPF + A-weighted)
256fs	83dB
512fs	93dB
1024fs	93dB

Table 13. Relationship between MCKI and S/N of LOUT/ROUT pins

The external clocks (MCKI, BICK and LRCK) should always be present whenever the ADC or DAC is in operation (PMADL bit = “1”, PMADR bit = “1” or PMDAC bit = “1”). If these clocks are not provided, the AK4648 may draw excess current and it is not possible to operate properly because utilizes dynamic refreshed logic internally. If the external clocks are not present, the ADC and DAC should be in the power-down mode (PMADL=PMADR=PMDAC bits = “0”).

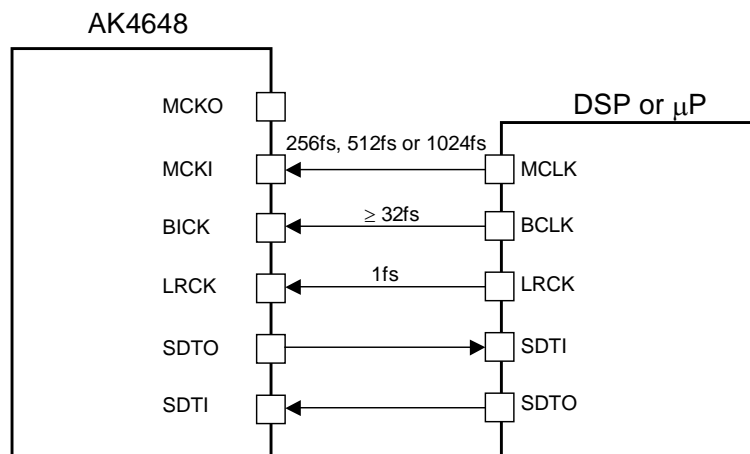

Figure 22. EXT Slave Mode

■ EXT Master Mode (PMPLL bit = “0”, M/S bit = “1”)

The AK4648 becomes EXT Master Mode by setting PMPLL bit = “0” and M/S bit = “1”. Master clock is input from MCKI pin, the internal PLL circuit is not operated. The clock required to operate is MCKI (256fs, 512fs or 1024fs). The input frequency of MCKI is selected by FS1-0 bits ((x: Don’t care) Table 14).

Mode	FS3-2 bits	FS1 bit	FS0 bit	MCKI Input Frequency	Sampling Frequency Range
0	x	0	0	256fs	7.35kHz ~ 48kHz
1	x	0	1	1024fs	7.35kHz ~ 13kHz
2	x	1	0	256fs	7.35kHz ~ 48kHz
3	x	1	1	512fs	7.35kHz ~ 26kHz

(x: Don’t care)

Table 14. MCKI Frequency at EXT Master Mode (PMPLL bit = “0”, M/S bit = “1”)

The S/N of the DAC at low sampling frequencies is worse than at high sampling frequencies due to out-of-band noise. The out-of-band noise can be improved by using higher frequency of the master clock. The S/N of the DAC output through LOUT/ROUT pins at fs=8kHz is shown in Table 15.

MCKI	S/N (fs=8kHz, 20kHzLPF + A-weighted)
256fs	83dB
512fs	93dB
1024fs	93dB

Table 15. Relationship between MCKI and S/N of LOUT/ROUT pins

MCKI should always be present whenever the ADC or DAC is in operation (PMADL bit = “1”, PMADR bit = “1” or PMDAC bit = “1”). If MCKI is not provided, the AK4648 may draw excess current and it is not possible to operate properly because utilizes dynamic refreshed logic internally. If MCKI is not present, the ADC and DAC should be in the power-down mode (PMADL=PMADR=PMDAC bits = “0”).

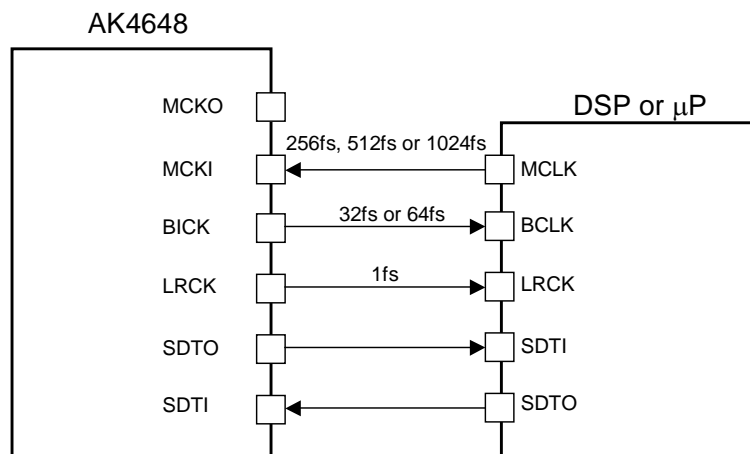

Figure 23. EXT Master Mode

BCKO bit	BICK Output Frequency
0	32fs
1	64fs

(default)

Table 16. BICK Output Frequency at Master Mode

■ System Reset

Upon power-up, the AK4648 should be reset by bringing the PDN pin = “L”. This ensures that all internal registers reset to their initial values.

The ADC enters an initialization cycle that starts when the PMADL or PMADR bit is changed from “0” to “1” at PMDAC bits is “0”. The initialization cycle time is $1059/f_s=24ms@f_s=44.1kHz$. During the initialization cycle, the ADC digital data outputs of both channels are forced to a 2’s complement, “0”. The ADC output reflects the analog input signal after the initialization cycle is complete. When PMDAC bit is “1”, the ADC does not require an initialization cycle.

The DAC enters an initialization cycle that starts when the PMDAC bit is changed from “0” to “1” at PMADL and PMADR bits are “0”. The initialization cycle time is $1059/f_s=24ms@f_s=44.1kHz$. During the initialization cycle, the DAC input digital data of both channels are internally forced to a 2’s complement, “0”. The DAC output reflects the digital input data after the initialization cycle is complete. When PMADL or PMADR bit is “1”, the DAC does not require an initialization cycle.

■ Audio Interface Format

Four types of data formats are available and are selected by setting the DIF1-0 bits (Table 17). In all modes, the serial data is MSB first, 2’s complement format. Audio interface formats can be used in both master and slave modes. LRCK and BICK are output from the AK4648 in master mode, but must be input to the AK4648 in slave mode.

Mode	DIF1 bit	DIF0 bit	SDTO (ADC)	SDTI (DAC)	BICK	Figure
0	0	0	DSP Mode	DSP Mode	$\geq 32fs$	Table 18
1	0	1	MSB justified	LSB justified	$\geq 32fs$	Figure 28
2	1	0	MSB justified	MSB justified	$\geq 32fs$	Figure 29
3	1	1	I ² S compatible	I ² S compatible	$\geq 32fs$	Figure 30

(default)

Table 17. Audio Interface Format

In modes 1, 2 and 3, the SDTO is clocked out on the falling edge (“↓”) of BICK and the SDTI is latched on the rising edge (“↑”). In Modes 0 (DSP mode), the audio I/F timing is changed by BCKP and MSBS bits (Table 18).

DIF1	DIF0	MSBS	BCKP	Audio Interface Format	Figure
0	0	0	0	MSB of SDTO is output by the rising edge (“↑”) of the first BICK after the rising edge (“↑”) of LRCK. MSB of SDTI is latched by the falling edge (“↓”) of the BICK just after the output timing of SDTO’s MSB.	Figure 24
		0	1	MSB of SDTO is output by the falling edge (“↓”) of the first BICK after the rising edge (“↑”) of LRCK. MSB of SDTI is latched by the rising edge (“↑”) of the BICK just after the output timing of SDTO’s MSB.	Figure 25
		1	0	MSB of SDTO is output by next rising edge (“↑”) of the falling edge (“↓”) of the first BICK after the rising edge (“↑”) of LRCK. MSB of SDTI is latched by the falling edge (“↓”) of the BICK just after the output timing of SDTO’s MSB.	Figure 26
		1	1	MSB of SDTO is output by next falling edge (“↓”) of the rising edge (“↑”) of the first BICK after the rising edge (“↑”) of LRCK. MSB of SDTI is latched by the rising edge (“↑”) of the BICK just after the output timing of SDTO’s MSB.	Figure 27

(default)

Table 18. Audio Interface Format in Mode 0

If 16-bit data that ADC outputs is converted to 8-bit data by removing LSB 8-bit, “-1” at 16bit data is converted to “-1” at 8-bit data. And when the DAC playbacks this 8-bit data, “-1” at 8-bit data will be converted to “-256” at 16-bit data and this is a large offset. This offset can be removed by adding the offset of “128” to 16-bit data before converting to 8-bit data.

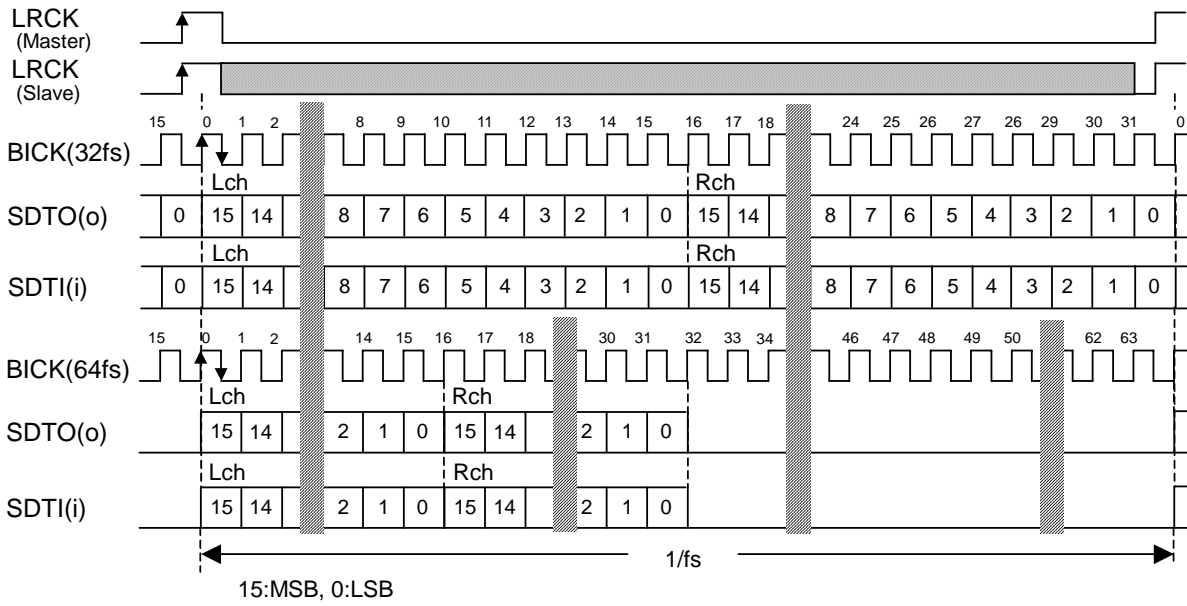

Figure 24. Mode 0 Timing (BCKP bit = "0", MSBS bit = "0")

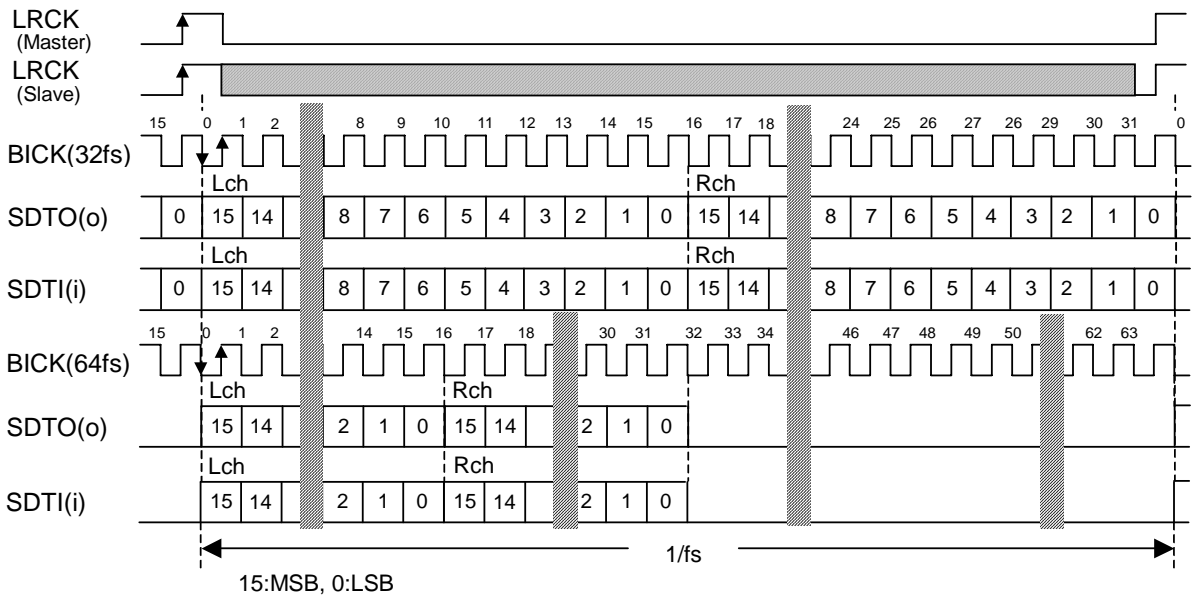

Figure 25. Mode 0 Timing (BCKP bit = "1", MSBS bit = "0")

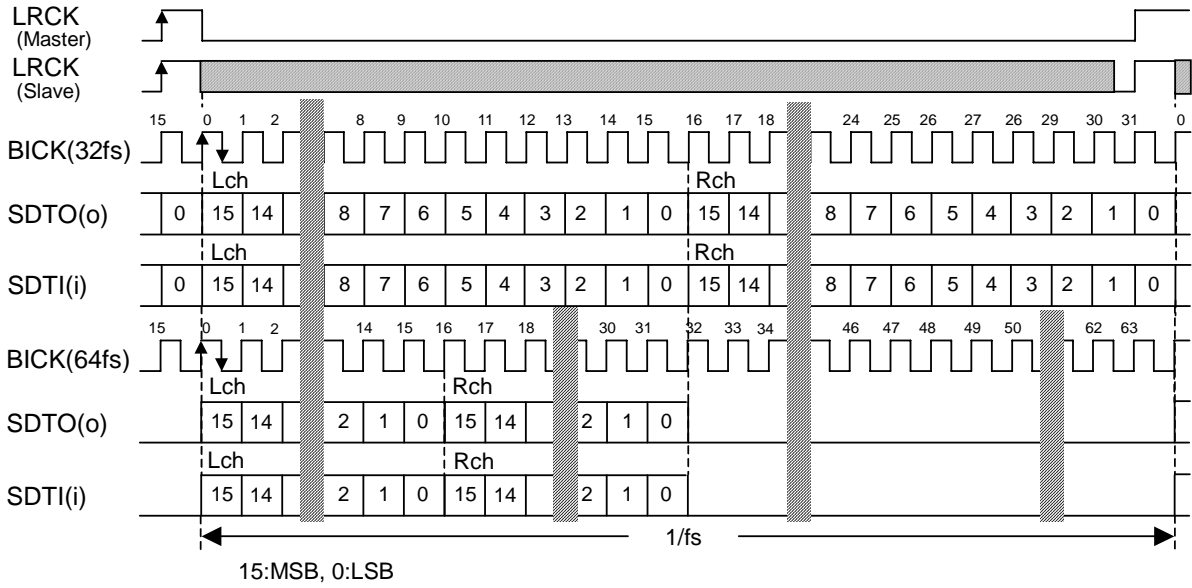

Figure 26. Mode 0 Timing (BCKP bit = "0", MSBS bit = "1")

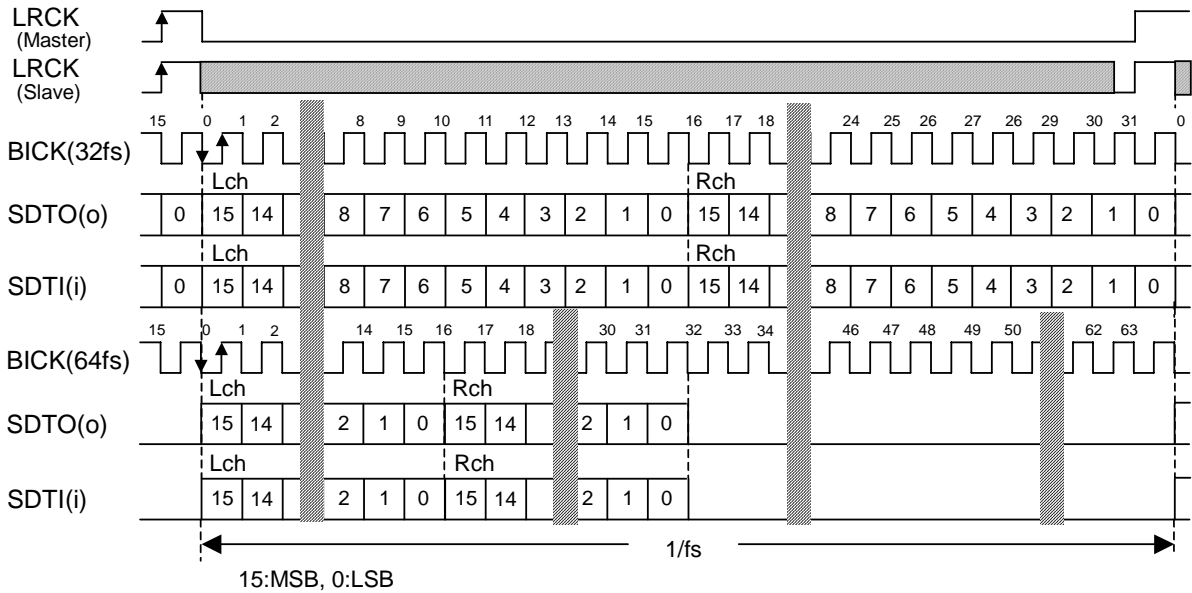

Figure 27. Mode 0 Timing (BCKP bit = "1", MSBS bit = "1")

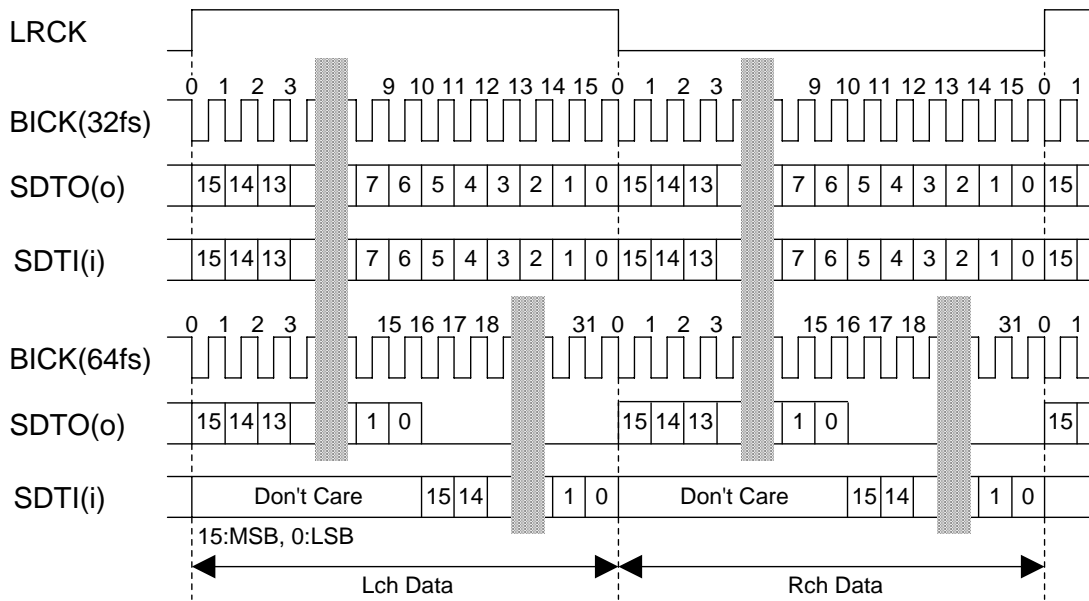

Figure 28. Mode 1 Timing

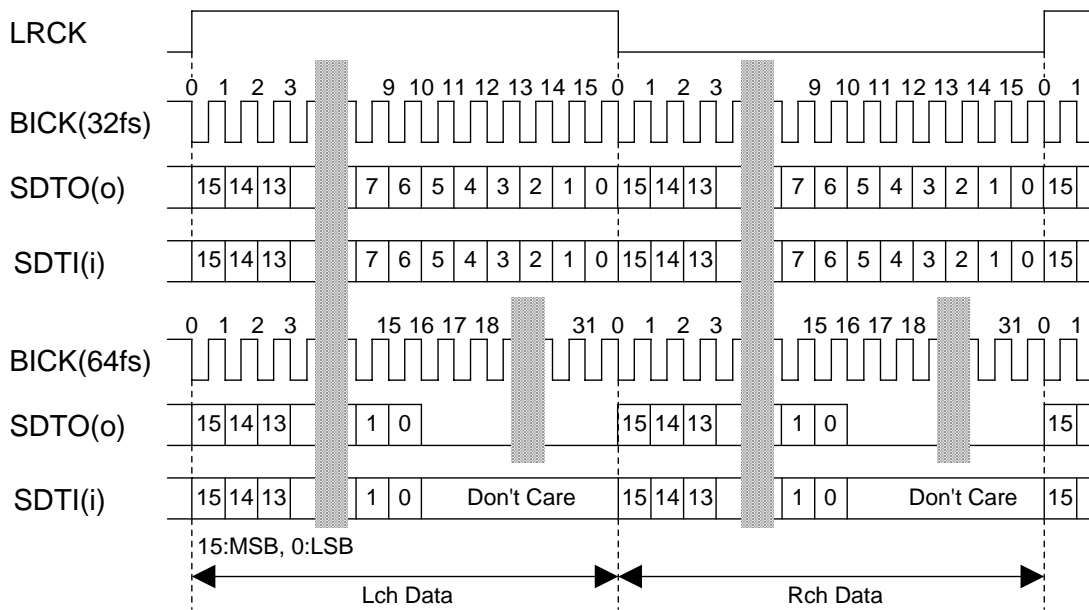

Figure 29. Mode 2 Timing

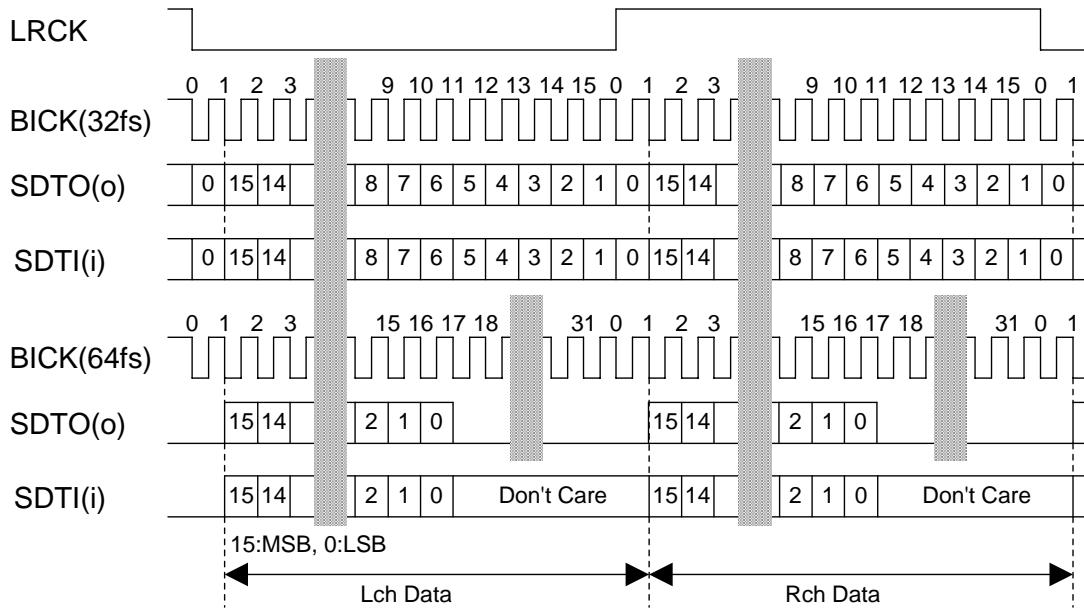

Figure 30. Mode 3 Timing

■ Mono/Stereo Mode

PMADL, PMADR and MIX bits set mono/stereo ADC operation. When MIX bit = "1", EQ and FIL3 bits should be set to "0". ALC operation (ALC bit = "1") or digital volume operation (ALC bit = "0") is applied to the data in Table 19.

PMADL bit	PMADR bit	MIX bit	ADC Lch data	ADC Rch data	
0	0	x	All "0"	All "0"	(default)
0	1	x	Rch Input Signal	Rch Input Signal	
1	0	x	Lch Input Signal	Lch Input Signal	
1	1	0	Lch Input Signal	Rch Input Signal	
		1	(L+R)/2	(L+R)/2	

Table 19. Mono/Stereo ADC operation (x: Don't care)

■ Digital High Pass Filter

The ADC has a digital high pass filter for DC offset cancellation. The cut-off frequency of the HPF is 0.9Hz (@fs=44.1kHz) and scales with sampling rate (fs). When PMADL bit = "1" or PMADR bit = "1", the HPF of ADC is enabled but the HPF of DAC is disabled. When PMADL=PMADR bits = "0", PMDAC bit = "1", the HPF of DAC is enabled but the HPF of ADC is disabled.

■ MIC/LINE Input Selector

The AK4648 has input selector for MIC-Amp. When MDIF1 and MDIF2 bits are “0”, INL1-0 and INR1-0 bits select LIN1/LIN2/LIN3/LIN4 and RIN1/RIN2/RIN3/RIN4, respectively. When MDIF1 and MDIF2 bits are “1”, LIN1, RIN1, LIN2 and RIN2 pins become IN1-, IN1+, IN2+ and IN2- pins respectively. In this case, full-differential input is available (Figure 32).

MDIF1 bit	MDIF2 bit	INL1 bit	INL0 bit	INR1 bit	INR0 bit	Lch	Rch
0	0	0	0	0	0	LIN1	RIN1
0	0	0	0	0	1	LIN1	RIN2
0	0	0	0	1	0	LIN1	RIN3
0	0	0	0	1	1	LIN1	RIN4
0	0	0	1	0	0	LIN2	RIN1
0	0	0	1	0	1	LIN2	RIN2
0	0	0	1	1	0	LIN2	RIN3
0	0	0	1	1	1	LIN2	RIN4
0	0	1	0	0	0	LIN3	RIN1
0	0	1	0	0	1	LIN3	RIN2
0	0	1	0	1	0	LIN3	RIN3
0	0	1	0	1	1	LIN3	RIN4
0	0	1	1	0	0	LIN4	RIN1
0	0	1	1	0	1	LIN4	RIN2
0	0	1	1	1	0	LIN4	RIN3
0	0	1	1	1	1	LIN4	RIN4
0	1	0	0	0	0	LIN1	IN2+/-
0	1	1	0	0	0	LIN3	IN2+/-
0	1	1	1	0	0	LIN4	IN2+/-
1	0	0	0	0	1	IN1+/-	RIN2
1	0	0	0	1	0	IN1+/-	RIN3
1	0	0	0	1	1	IN1+/-	RIN4
1	1	0	0	0	0	IN1+/-	IN2+/-
Others						N/A	N/A

Table 20. MIC/Line In Path Select (N/A: Not Available)

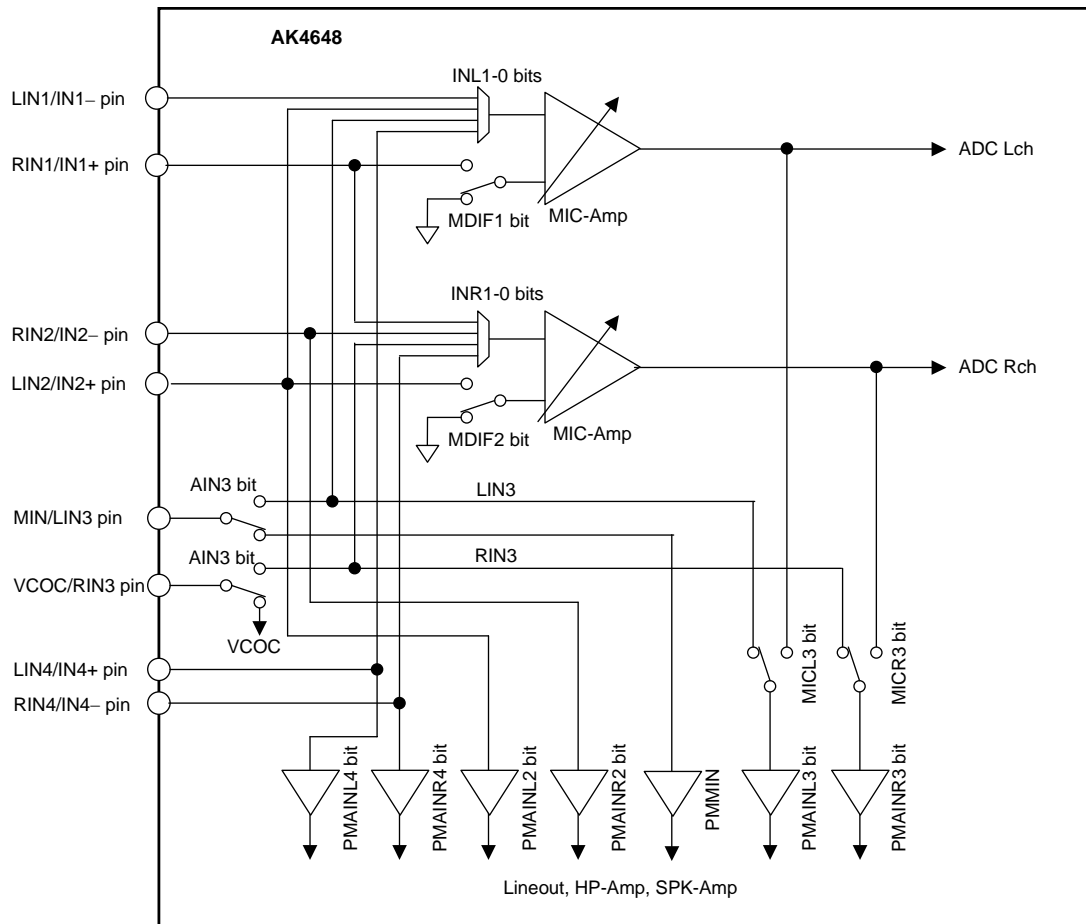

Figure 31. Mic/Line Input Selector

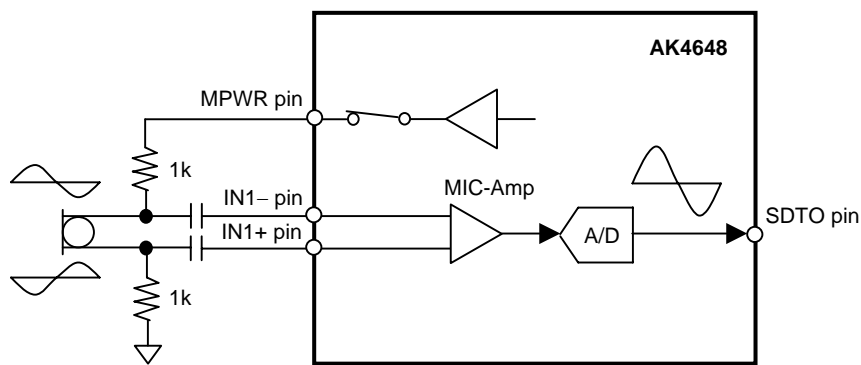

Figure 32. Connection Example for Full-differential Mic Input (MDIF1/2 bits = "1")

<Input Selector Setting Example>

In case that IN1+/- pins are used as full-differential mic input and LIN2/RIN2 pins are used as stereo line input, it is recommended that the following two modes are set by register setting according to each case.

MDIF1 bit	MDIF2 bit	INL1 bit	INL0 bit	INR1 bit	INR0 bit	Lch	Rch
1	0	0	0	0	1	IN1+/-	RIN2
0	0	0	1	0	1	LIN2	RIN2

Table 21. MIC/Line In Path Select Example

■ MIC Gain Amplifier

The AK4648 has a gain amplifier for microphone input. The gain of MIC-Amp is selected by the MGAIN1-0 bits (Table 22). The typical input impedance is $60k\Omega$ (typ.) @ MGAIN1-0 bits = "00" or $30k\Omega$ (typ) @ MGAIN1-0 bits = "01", "10" or "11".

MGAIN1 bit	MGAIN0 bit	Input Gain
0	0	0dB
0	1	+20dB
1	0	+26dB
1	1	+32dB

(default)

Table 22. Mic Input Gain

■ MIC Power

When PMMP bit = "1", the MPWR pin supplies power for the microphone. This output voltage is typically $0.75 \times AVDD$ and the load resistance is minimum $0.5k\Omega$. In case of using two sets of stereo mic, the load resistance is minimum $2k\Omega$ for each channel. Capacitor must not be connected directly to MPWR pin (Figure 33).

PMMP bit	MPWR pin
0	Hi-Z
1	Output

(default)

Table 23. MIC Power

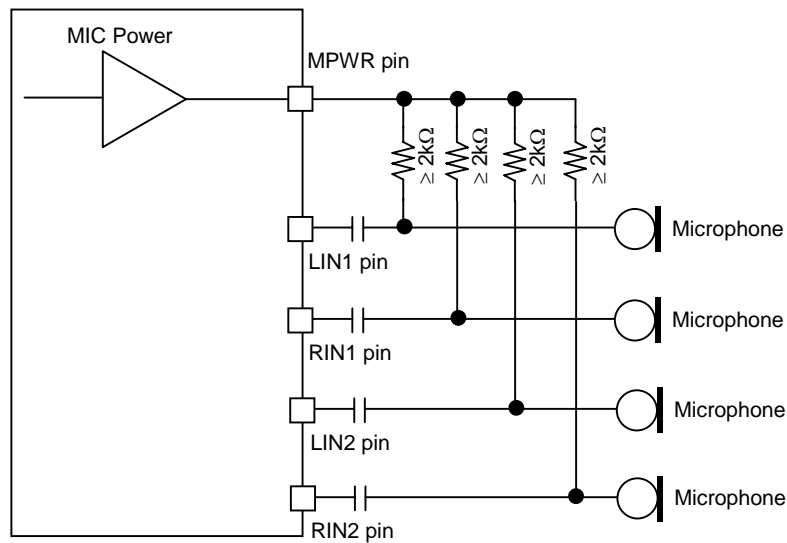

Figure 33. MIC Block Circuit

■ Digital EQ/HPF/LPF

The AK4648 performs wind-noise reduction filter, stereo separation emphasis, gain compensation and ALC (Automatic Level Control) by digital domain for A/D converted data (Figure 34). FIL1, FIL3 and EQ blocks are IIR filters of 1st order. The filter coefficient of FIL3, EQ and FIL1 blocks can be set to any value. Refer to the section of “ALC operation” about ALC.

When only DAC is powered-up, digital EQ/HPF/LPF circuit operates at playback path. When only ADC is powered-up or both ADC and DAC are powered-up, digital EQ/HPF/LPF circuit operates at recording path. Even if the path is switched from recording to playback, the register setting of filter coefficient at recording remains. Therefore, FIL3, EQ, FIL1 and GN1-0 bits should be set to “0” if digital EQ/HPF/LPF is not used for playback path.

PMADL bit, PMADR bit	PMDAC bit	LOOP bit	Status	Digital EQ/HPF/LPF
00	0	x	Power-down	Power-down
	1	x	Playback	Playback path
01, 10 or 11	0	x	Recording	Recording path
	1	0	Recording & Playback	Recording path
		1	Recording Monitor Playback	Recording path

Note 55. Stereo separation emphasis circuit is effective only at stereo operation.

Table 24. Digital EQ/HPF/LPF Circuit Setting (x: Don't care)

FIL3 coefficient also sets the attenuation of the stereo separation emphasis.

The combination of GN1-0 bit (Table 25) and EQ coefficient set the compensation gain.

FIL1 and FIL3 blocks become HPF when F1AS and F3AS bits are “0” and become LPF when F1AS and F3AS bits are “1”, respectively.

When EQ and FIL1 bits are “0”, EQ and FIL1 blocks become “through” (0dB). When FIL3 bit is “0”, FIL3 block become “MUTE”. When each filter coefficient is changed, each filter should be set to “through” (“MUTE” in case of FIL3).

When MIX bit = “1”, only FIL1 is available. In this case, EQ and FIL3 bits should be set to “0”.

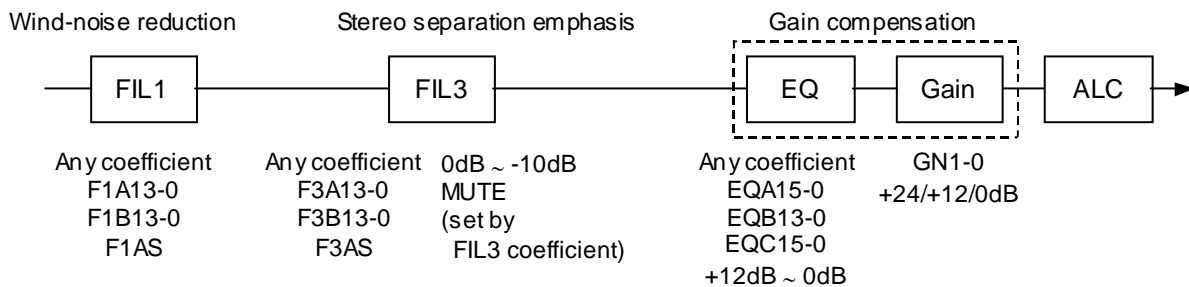

Figure 34. Digital EQ/HPF/LPF

GN1	GN0	Gain
0	0	0dB
0	1	+12dB
1	x	+24dB

Table 25. Gain select of gain block (x: Don't care)

[Filter Coefficient Setting]

1) When FIL1 and FIL3 are set to “HPF”

fs: Sampling frequency
 fc: Cut-off frequency
 f: Input signal frequency
 K: Filter gain [dB] (Filter gain of should be set to 0dB.)

Register setting

FIL1: F1AS bit = “0”, F1A[13:0] bits =A, F1B[13:0] bits =B
 FIL3: F3AS bit = “0”, F3A[13:0] bits =A, F3B[13:0] bits =B
 (MSB=F1A13, F1B13, F3A13, F3B13; LSB=F1A0, F1B0, F3A0, F3B0)

$$A = 10^{K/20} \times \frac{1 / \tan (\pi f c / f s)}{1 + 1 / \tan (\pi f c / f s)}, \quad B = \frac{1 - 1 / \tan (\pi f c / f s)}{1 + 1 / \tan (\pi f c / f s)}$$

Transfer function	Amplitude	Phase
$H(z) = A \frac{1 - z^{-1}}{1 + Bz^{-1}}$	$M(f) = A \sqrt{\frac{2 - 2\cos (2\pi f / f s)}{1 + B^2 + 2B\cos (2\pi f / f s)}}$	$\theta(f) = \tan^{-1} \frac{(B+1)\sin (2\pi f / f s)}{1 - B + (B-1)\cos (2\pi f / f s)}$

2) When FIL1 and FIL3 are set to “LPF”.

fs: Sampling frequency
 fc: Cut-off frequency
 f: Input signal frequency
 K: Filter gain [dB] (Filter gain of FIL1 should be set to 0dB.)

Register setting

FIL1: F1AS bit = “1”, F1A[13:0] bits =A, F1B[13:0] bits =B
 FIL3: F3AS bit = “1”, F3A[13:0] bits =A, F3B[13:0] bits =B
 (MSB=F1A13, F1B13, F3A13, F3B13; LSB=F1A0, F1B0, F3A0, F3B0)

$$A = 10^{K/20} \times \frac{1}{1 + 1 / \tan (\pi f c / f s)}, \quad B = \frac{1 - 1 / \tan (\pi f c / f s)}{1 + 1 / \tan (\pi f c / f s)}$$

Transfer function	Amplitude	Phase
$H(z) = A \frac{1 + z^{-1}}{1 + Bz^{-1}}$	$M(f) = A \sqrt{\frac{2 + 2\cos (2\pi f / f s)}{1 + B^2 + 2B\cos (2\pi f / f s)}}$	$\theta(f) = \tan^{-1} \frac{(B-1)\sin (2\pi f / f s)}{1 + B + (B+1)\cos (2\pi f / f s)}$

3) EQ

fs: Sampling frequency
 fc₁: Pole frequency
 fc₂: Zero-point frequency
 f: Input signal frequency
 K: Filter gain [dB] (Maximum +12dB)

Register setting

EQA[15:0] bits =A, EQB[13:0] bits =B, EQC[15:0] bits =C
 (MSB=EQA15, EQB13, EQC15; LSB=EQA0, EQB0, EQC0)

$$A = 10^{K/20} \times \frac{1 + 1 / \tan(\pi fc_2 / fs)}{1 + 1 / \tan(\pi fc_1 / fs)}, \quad B = \frac{1 - 1 / \tan(\pi fc_1 / fs)}{1 + 1 / \tan(\pi fc_1 / fs)}, \quad C = 10^{K/20} \times \frac{1 - 1 / \tan(\pi fc_2 / fs)}{1 + 1 / \tan(\pi fc_1 / fs)}$$

Transfer function	Amplitude	Phase
$H(z) = \frac{A + Cz^{-1}}{1 + Bz^{-1}}$	$M(f) = \sqrt{\frac{A^2 + C^2 + 2AC \cos(2\pi f / fs)}{1 + B^2 + 2B \cos(2\pi f / fs)}}$	$\theta(f) = \tan^{-1} \frac{(AB - C) \sin(2\pi f / fs)}{A + BC + (AB + C) \cos(2\pi f / fs)}$

[Translation the filter coefficient calculated by the equations above from real number to binary code (2's complement)]

$$X = (\text{Real number of filter coefficient calculated by the equations above}) \times 2^{13}$$

X should be rounded to integer, and then should be translated to binary code (2's complement).
 MSB of each filter coefficient setting register is sine bit.

[Filter Coefficient Setting Example]

1) FIL1 Block

Example: HPF, fs=44.1kHz, fc=100Hz
 F1AS bit = "0"
 F1A[13:0] bits = 01 1111 1100 0110
 F1B[13:0] bits = 10 0000 0111 0100

2) EQ block

Example: fs=44.1kHz, fc₁=300Hz, fc₂=3000Hz, Gain=+8dB

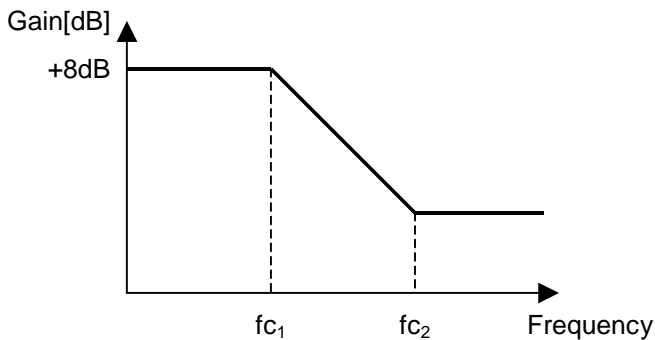

EQA[15:0] bits = 0000 1001 0110 1110
 EQB[13:0] bits = 10 0001 0101 1001
 EQC[15:0] bits = 1111 1001 1110 1111

■ ALC Operation

The ALC (Automatic Level Control) is operated by ALC block when ALC bit is “1”. When only DAC is powered-up, ALC circuit operates at playback path. When only ADC is powered-up or both ADC and DAC are powered-up, ALC circuit operates at recording path.

PMADL bit, PMADR bit	PMDAC bit	LOOP bit	Status	ALC	
00	0	x	Power-down	Power-down	(default)
	1	x	Playback	Playback path	
01, 10 or 11	0	x	Recording	Recording path	
	1	0	Recording & Playback	Recording path	
		1	Recording Monitor Playback	Recording path	

Table 26. ALC Setting (x: Don't care)

1. ALC Limiter Operation

During the ALC limiter operation, when either Lch or Rch exceeds the ALC limiter detection level (Table 27), the IVL and IVR values (same value) are attenuated automatically to the amount defined by the ALC limiter ATT step (Table 28). The IVL and IVR are then set to the same value for both channels.

When ZELMN bit = “0” (zero cross detection is enabled), the IVL and IVR values are changed by ALC limiter operation at the individual zero crossing points of Lch and Rch or at the zero crossing timeout. ZTM1-0 bits set the zero crossing timeout period of both ALC limiter and recovery operation (Table 29).

When ZELMN bit = “1” (zero cross detection is disabled), IVL and IVR values are immediately (period: 1/fs) changed by ALC limiter operation. Attenuation step is fixed to 1 step regardless as the setting of LMAT1-0 bits.

The attenuate operation is done continuously until the input signal level becomes ALC limiter detection level (Table 27) or less. After completing the attenuate operation, unless ALC bit is changed to “0”, the operation repeats when the input signal level exceeds LMTH1-0 bits.

LMTH1	LMTH0	ALC Limier Detection Level	ALC Recovery Waiting Counter Reset Level	
0	0	ALC Output \geq -2.5dBFS	-2.5dBFS > ALC Output \geq -4.1dBFS	(default)
0	1	ALC Output \geq -4.1dBFS	-4.1dBFS > ALC Output \geq -6.0dBFS	
1	0	ALC Output \geq -6.0dBFS	-6.0dBFS > ALC Output \geq -8.5dBFS	
1	1	ALC Output \geq -8.5dBFS	-8.5dBFS > ALC Output \geq -12dBFS	

Table 27. ALC Limiter Detection Level / Recovery Counter Reset Level

ZELMN	LMAT1	LMAT0	ALC Limiter ATT Step		
0	0	0	1 step	0.375dB	(default)
	0	1	2 step	0.750dB	
	1	0	4 step	1.500dB	
	1	1	8 step	3.000dB	
1	x	x	1step	0.375dB	

Table 28. ALC Limiter ATT Step (x: Don't care)

ZTM1	ZTM0	Zero Crossing Timeout Period				
			8kHz	16kHz	44.1kHz	
0	0	128/fs	16ms	8ms	2.9ms	(default)
0	1	256/fs	32ms	16ms	5.8ms	
1	0	512/fs	64ms	32ms	11.6ms	
1	1	1024/fs	128ms	64ms	23.2ms	

Table 29. ALC Zero Crossing Timeout Period

2. ALC Recovery Operation

The ALC recovery operation waits for the WTM2-0 bits (Table 30) to be set after completing the ALC limiter operation. If the input signal does not exceed “ALC recovery waiting counter reset level” (Table 27) during the wait time, the ALC recovery operation is done. The IVL and IVR values are automatically incremented by RGAIN1-0 bits (Table 31) up to the set reference level (Table 32) with zero crossing detection which timeout period is set by ZTM1-0 bits (Table 29). Then the IVL and IVR are set to the same value for both channels. The ALC recovery operation is done at a period set by WTM2-0 bits. When zero cross is detected at both channels during the wait period set by WTM2-0 bits, the ALC recovery operation waits until WTM2-0 period and the next recovery operation is done. If ZTM1-0 is longer than WTM2-0 and no zero crossing occurs, the ALC recovery operation is done at a period set by ZTM1-0 bits.

For example, when the current IVOL value is 30H and RGAIN1-0 bits are set to “01”, IVOL is changed to 32H by the auto limiter operation and then the input signal level is gained by 0.75dB (=0.375dB x 2). When the IVOL value exceeds the reference level (REF7-0), the IVOL values are not increased.

When

“ALC recovery waiting counter reset level (LMTH1-0) ≤ Output Signal < ALC limiter detection level (LMTH1-0)” during the ALC recovery operation, the waiting timer of ALC recovery operation is reset. When

“ALC recovery waiting counter reset level (LMTH1-0) > Output Signal”, the waiting timer of ALC recovery operation starts.

The ALC operation corresponds to the impulse noise. When the impulse noise is input, the ALC recovery operation becomes faster than a normal recovery operation (Fast Recovery Operation). When large noise is input to microphone instantaneously, the quality of small signal level in the large noise can be improved by this fast recovery operation. The speed of fast recovery operation is set by RFST1-0 bits (Table 33).

WTM2	WTM1	WTM0	ALC Recovery Operation Waiting Period				
			8kHz	16kHz	44.1kHz		
0	0	0	128/fs	16ms	8ms	2.9ms	(default)
0	0	1	256/fs	32ms	16ms	5.8ms	
0	1	0	512/fs	64ms	32ms	11.6ms	
0	1	1	1024/fs	128ms	64ms	23.2ms	
1	0	0	2048/fs	256ms	128ms	46.4ms	
1	0	1	4096/fs	512ms	256ms	92.9ms	
1	1	0	8192/fs	1024ms	512ms	185.8ms	
1	1	1	16384/fs	2048ms	1024ms	371.5ms	

Table 30. ALC Recovery Operation Waiting Period

RGAIN1	RGAIN0	GAIN STEP		
0	0	1 step	0.375dB	(default)
0	1	2 step	0.750dB	
1	0	3 step	1.125dB	
1	1	4 step	1.500dB	

Table 31. ALC Recovery GAIN Step

REF7-0	GAIN(dB)	Step
F1H	+36.0	0.375dB (default)
F0H	+35.625	
EFH	+35.25	
:	:	
E2H	+30.375	
E1H	+30.0	
E0H	+29.625	
:	:	
03H	-53.25	
02H	-53.625	
01H	-54.0	
00H	MUTE	

Table 32. Reference Level at ALC Recovery operation

RFST1 bit	RFST0 bit	Recovery Speed
0	0	4 times
0	1	8 times
1	0	16times
1	1	N/A

Table 33. Fast Recovery Speed Setting

3. Example of ALC Operation

Table 34 shows the examples of the ALC setting for MIC recording.

Register Name	Comment	fs=8kHz		fs=44.1kHz	
		Data	Operation	Data	Operation
LMTH1-0	Limiter detection Level	01	-4.1dBFS	01	-4.1dBFS
ZELMN	Limiter zero crossing detection	0	Enable	0	Enable
ZTM1-0	Zero crossing timeout period	01	32ms	11	23.2ms
WTM2-0	Recovery waiting period *WTM2-0 bits should be the same or longer data as ZTM1-0 bits.	001	32ms	011	23.2ms
REF7-0	Maximum gain at recovery operation	E1H	+30dB	E1H	+30dB
IVL7-0, IVR7-0	Gain of IVOL	E1H	+30dB	E1H	+30dB
LMAT1-0	Limiter ATT step	00	1 step	00	1 step
RGAIN1-0	Recovery GAIN step	00	1 step	00	1 step
RFST1-0	Fast Recovery Speed	00	4 times	00	4 times
ALC	ALC enable	1	Enable	1	Enable

Table 34. Example of the ALC setting

The following registers should not be changed during the ALC operation. These bits should be changed after the ALC operation is finished by ALC bit = "0" or PMADL=PMADR bits = "0".

- **LMTH1-0, LMAT1-0, WTM2-0, ZTM1-0, RGAIN1-0, REF7-0, ZELMN and RFST1-0 bits**

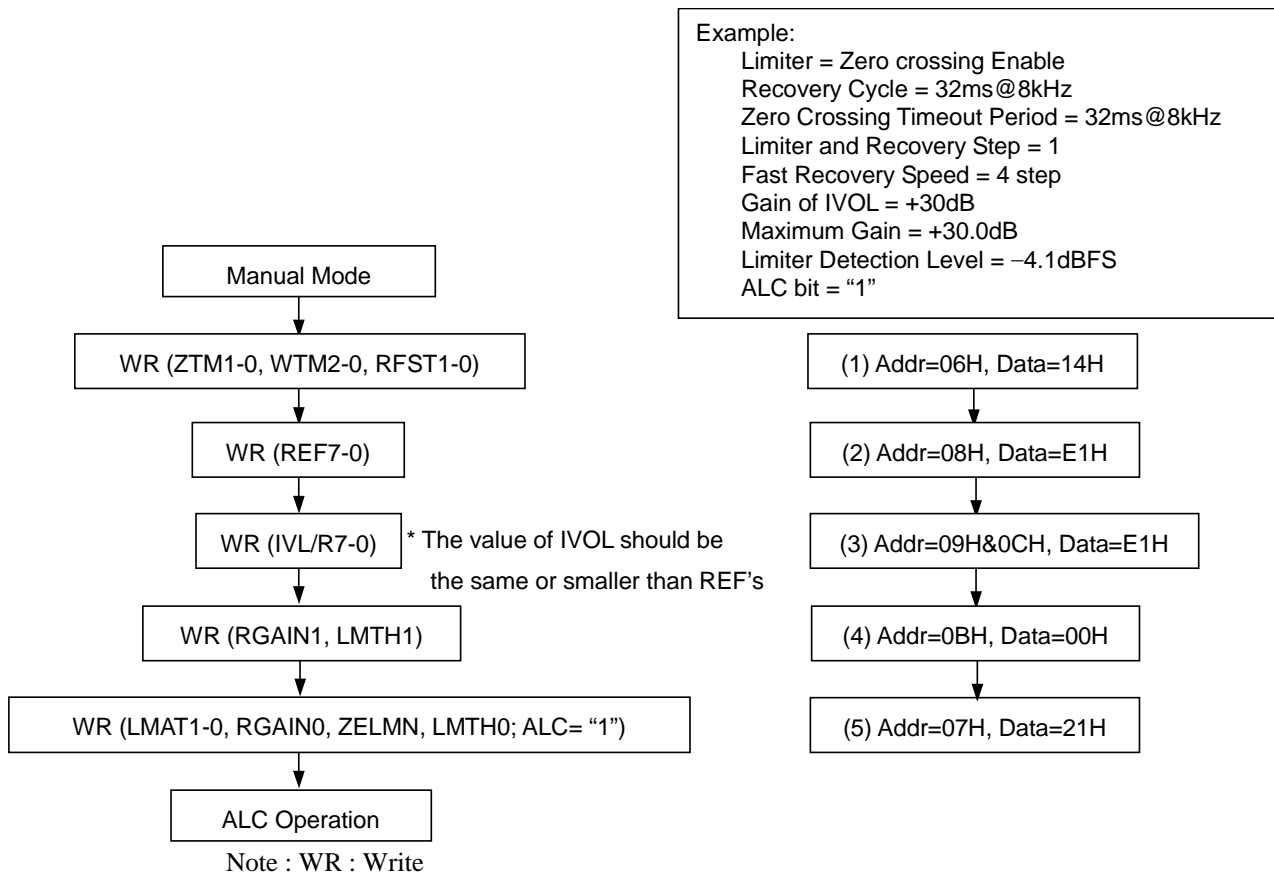

Figure 35. Registers set-up sequence at ALC operation

■ Input Digital Volume (Manual Mode)

The input digital volume becomes a manual mode when ALC bit is “0”. This mode is used in the case shown below.

1. After exiting reset state, set-up the registers for the ALC operation (ZTM1-0, LMTH1-0 and etc)
2. When the registers for the ALC operation (Limiter period, Recovery period and etc) are changed.
For example; when the change of the sampling frequency.
3. When IVOL is used as a manual volume.

IVL7-0 and IVR7-0 bits set the gain of the volume control (Table 35). The IVOL value is changed at zero crossing or timeout. Zero crossing timeout period is set by ZTM1-0 bits. If IVL7-0 or IVR7-0 bits are written during PMADL=PMADR bits = “0”, IVOL operation starts with the written values at the end of the ADC initialization cycle after PMADL or PMADR bit is changed to “1”.

Even if the path is switched from recording to playback, the register setting of IVOL remains. Therefore, IVL7-0 and IVR7-0 bits should be set to “91H” (0dB).

IVL7-0 IVR7-0	GAIN (dB)	Step
F1H	+36.0	0.375dB (default)
F0H	+35.625	
EFH	+35.25	
:	:	
E2H	+30.375	
E1H	+30.0	
E0H	+29.625	
:	:	
03H	-53.25	
02H	-53.625	
01H	-54	
00H	MUTE	

Table 35. Input Digital Volume Setting

When writing to the IVL7-0 and IVR7-0 bits continuously, the control register should be written with an interval more than zero crossing timeout. If not, IVL and IVR are not changed since zero crossing counter is reset at every write operation. If the same register value as the previous write operation is written to IVL and IVR, this write operation is ignored and zero crossing counter is not reset. Therefore, IVL and IVR can be written with an interval less than zero crossing timeout.

ALC bit			
ALC Status	Disable	Enable	Disable
IVL7-0 bits	E1H(+30dB)		
IVR7-0 bits	C6H(+20dB)		
Internal IVL	E1H(+30dB)	E1(+30dB) --> F1(+36dB)	E1(+30dB)
Internal IVR	C6H(+20dB)	E1(+30dB) --> F1(+36dB)	C6H(+20dB)

Figure 36. IVOL value during ALC operation

- (1) The IVL value becomes the start value if the IVL and IVR are different when the ALC starts.
- (2) Writing to IVL and IVR registers (09H and 0CH) is ignored during ALC operation. After ALC is disabled, the IVOL changes to the last written data by zero crossing or timeout. When ALC is enabled again, ALC bit should be set to "1" by an interval more than zero crossing timeout period after ALC bit = "0".

■ De-emphasis Filter

The AK4648 includes the digital de-emphasis filter ($t_c = 50/15\mu s$) by IIR filter. Setting the DEM1-0 bits enables the de-emphasis filter (Table 36).

DEM1	DEM0	Mode
0	0	44.1kHz
0	1	OFF
1	0	48kHz
1	1	32kHz

(default)

Table 36. De-emphasis Control

■ 5 Band Equalizer

The AK4648 has 5 Band Equalizer on DAC block. The center frequencies and cut/boost amount are selected by FBEQx3-0 bits (Table 37).

- Center frequency: 100Hz, 250Hz, 1kHz, 3.5kHz, and 10kHz (Note 56, Note 57)
- Cut/Boost amount: Minimum -10.5dB , Maximum $+12\text{dB}$, Step 1.5dB

Note 56: These are the frequencies when the sampling frequency is 44.1kHz. These frequencies are proportional to the sampling frequency.

Note 57: 100Hz is not center frequency but the frequency component lower than 100Hz is controlled.

Note 58: 10kHz is not center frequency but the frequency component higher than 10kHz is controlled.

FBEQ bit controls ON/OFF of this Equalizer.

- FBEQA3-0: Select the boost level of 100Hz
- FBEQB3-0: Select the boost level of 250Hz
- FBEQC3-0: Select the boost level of 1kHz
- FBEQD3-0: Select the boost level of 3.5kHz
- FBEQE3-0: Select the boost level of 10kHz

FBEQx3-0	Boost amount
0H	+12.0dB
1H	+10.5dB
2H	+9.0dB
3H	+7.5dB
:	:
8H	0dB
:	:
DH	-7.5dB
EH	-9.0dB
FH	-10.5dB

(default)

Table 37. Boost amount of 5 Band Equalizer

■ Digital Output Volume

The AK4648 has a digital output volume (256 levels, 0.5dB step, Mute). The volume can be set by the DVL7-0 and DVR7-0 bits. The volume is included in front of a DAC block. The input data of DAC is changed from +12 to -115dB or MUTE. When the DVOLC bit = "1", the DVL7-0 bits control both Lch and Rch attenuation levels. When the DVOLC bit = "0", the DVL7-0 bits control Lch level and DVR7-0 bits control Rch level. This volume has a soft transition function. The DVTM bit sets the transition time between set values of DVL/R7-0 bits as either 1061/fs or 256/fs (Table 39). When DVTM bit = "0", a soft transition between the set values occurs (1062 levels). It takes 1061/fs (=24ms@fs=44.1kHz) from 00H (+12dB) to FFH (MUTE).

DVL/R7-0	Gain	Step
00H	+12.0dB	0.5dB (default)
01H	+11.5dB	
02H	+11.0dB	
:	:	
18H	0dB	
:	:	
FDH	-114.5dB	
FEH	-115.0dB	
FFH	MUTE ($-\infty$)	

Table 38. Digital Volume Code Table

DVTM bit	Transition time between DVL/R7-0 bits = 00H and FFH		
	Setting	fs=8kHz	fs=44.1kHz
0	1061/fs	133ms	24ms
1	256/fs	32ms	6ms

Table 39. Transition Time Setting of Digital Output Volume

■ Soft Mute

Soft mute operation is performed in the digital domain. When the SMUTE bit goes to “1”, the output signal is attenuated by $-\infty$ (“0”) during the cycle set by the DVTM bit. When the SMUTE bit is returned to “0”, the mute is cancelled and the output attenuation gradually changes to the value set by the DVL/R7-0 bits during the cycle set of the DVTM bit. If the soft mute is cancelled within the cycle set by the DVTM bit after starting the operation, the attenuation is discontinued and returned to the value set by the DVL/R7-0 bits. The soft mute is effective for changing the signal source without stopping the signal transmission (Figure 37).

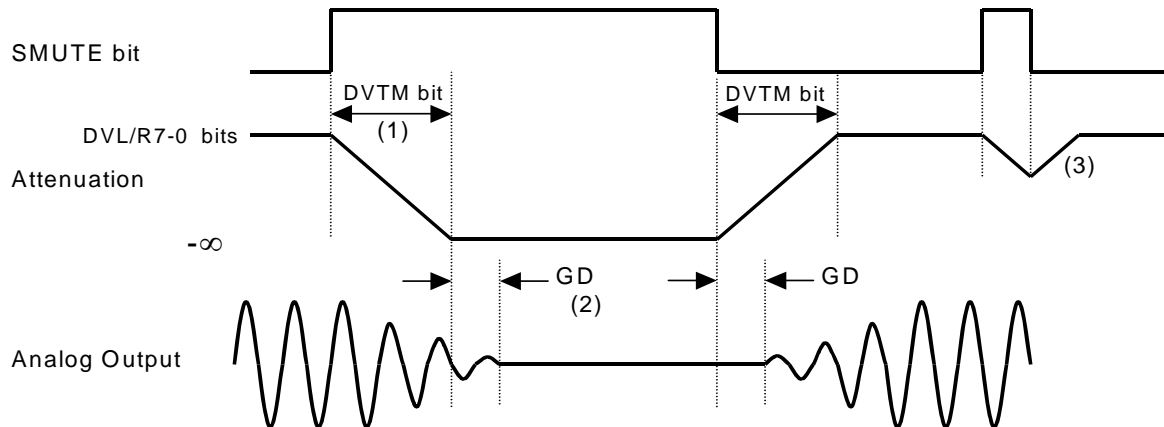

Figure 37. Soft Mute Function

- (1) The output signal is attenuated until $-\infty$ (“0”) by the cycle set by the DVTM bit.
- (2) Analog output corresponding to digital input has the group delay (GD).
- (3) If the soft mute is cancelled within the cycle set by the DVTM bit, the attenuation is discontinued and returned to the value set by the DVL/R7-0 bits.

■ Analog Mixing: Stereo Input (LIN2/RIN2/LIN4/RIN4, AIN3 bit = “1”: LIN3/RIN3 pins)

When PMAINL2=PMAINR2 bits = “1”, LIN2 and RIN2 pins can be used as stereo line input for analog mixing. When the LINS2 and RINS2 bits are set to “1”, the input signal from the LIN2/RIN2 pins is output from Speaker-Amp. When the LINH2 and RINH2 bits are set to “1”, the input signal from the LIN2/RIN2 pins is output from Headphone-Amp. When the LINL2/RINR2 bits are set to “1”, the input signal from the LIN2/RIN2 pins is output from the stereo line output amplifier.

When PMAINL4=PMAINR4 bits = “1”, LIN4 and RIN4 pins can be used as stereo line input for analog mixing. When the LINS4 and RINS4 bits are set to “1”, the input signal from the LIN4/RIN4 pins is output from Speaker-Amp. When the LINH4 and RINH4 bits are set to “1”, the input signal from the LIN4/RIN4 pins is output from Headphone-Amp. When the LINL4/RINR4 bits are set to “1”, the input signal from the LIN4/RIN4 pins is output from the stereo line output amplifier.

When the analog mixing is used, A/D converter is also available if PMADL or PMADR bit is “1”. In this case, the input resistance of LIN2/RIN2/LIN4/RIN4 pins becomes 30kΩ (typ.) at MGAIN1-0 bits = “00” and 20kΩ (typ.) at MGAIN1-0 bits = “01”, “10” or “11”, respectively.

Pin	bit			MGAIN1-0 bits	Input Impedance (typ.)
	LIN2/RIN2	PMAINL2/PMAINR2	PMMICL/PMICR or PMADL/PMADR		
/	0	1		00	60k
				01, 10 or 11	30k
	1	0	0	00	60k
				01, 10 or 11	30k
		1	1	00	30k
				01, 10 or 11	20k

Table 40. Input Impedance of LIN2/RIN2/LIN4/RIN4 pins

When AIN3 bit = “1”, MIN and VCOC pins become LIN3 and RIN3 pins, respectively. In this case, PLL is not available. When PMAINL3=PMAINR3 bits = “1”, LIN3 and RIN3 pins can be used as stereo line input for analog mixing. When PMMICL=PMMICR=MICL3=MICR3 bits = “1”, analog mixing source is changed from LIN3/RIN3 input to MIC-Amp output signal. When the LINS3 and RINS3 bits are set to “1”, the input signal from the LIN3/RIN3 pins is output from Speaker-Amp. When the LINH3 and RINH3 bits are set to “1”, the input signal from the LIN3/RIN3 pins is output from Headphone-Amp. When the LINL3/RINR3 bits are set to “1”, the input signal from the LIN3/RIN3 pins is output from the stereo line output amplifier.

When the analog mixing is used, A/D converter is also available if PMADL or PMADR bit is “1”. When the analog mixing is used at MICL3=MICR3 bits = “0”, the input resistance of LIN3/RIN3 pins becomes 30kΩ (typ.) at MGAIN1-0 bits = “00” and 20kΩ (typ.) at MGAIN1-0 bits = “01”, “10” or “11”, respectively. When the analog mixing is used at MICL3=MICR3 bits = “1”, the input resistance of LIN3/RIN3 pins becomes 60kΩ (typ.) at MGAIN1-0 bits = “00” and 30kΩ (typ.) at MGAIN1-0 bits = “01”, “10” or “11”, respectively.

Pin	bit				MGAIN1-0 bits	Input Impedance (typ.)
	LIN3/RIN3	PMAINL3/PMAINR3	PMMICL/PMICR or PMADL/PMADR	MICL3/MICR3		
/	0	1		x	00	60k
					01, 10 or 11	30k
	1	0		0	00	60k
					01, 10 or 11	30k
		1	1		0	30k
					01, 10 or 11	20k
				1	00	60k
					01, 10 or 11	30k

Table 41. Input Impedance of LIN3/RIN3 pins (AIN3 bit = “1”; x: Don't care)

Table 42, Table 43, Table 44, and Table 45 show the typical gain.

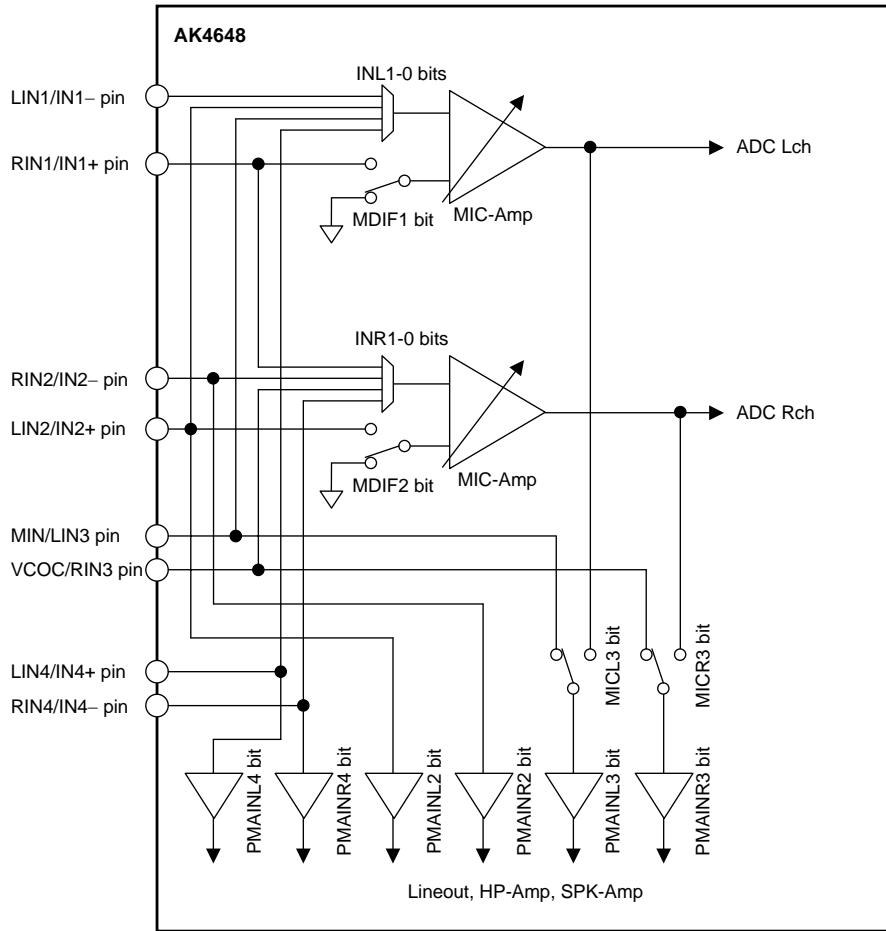

Figure 38. Analog Mixing Circuit (Stereo Input)

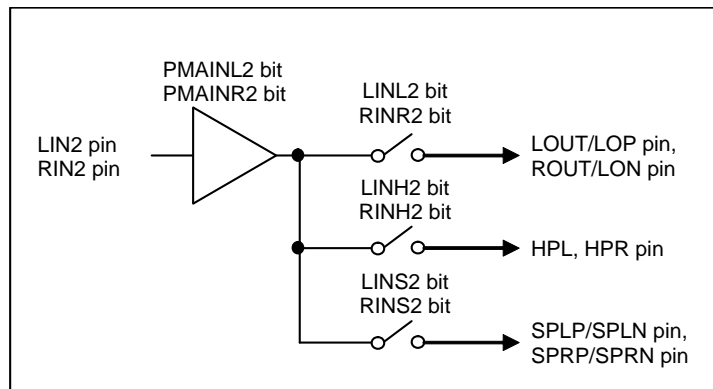

Figure 39. Analog Mixing Circuit (LIN2/RIN2)

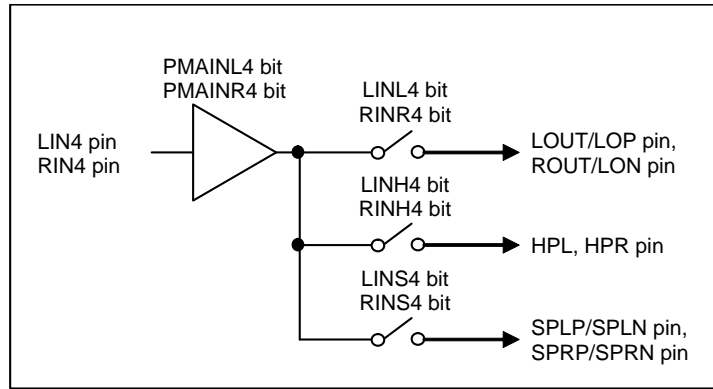

Figure 40. Analog Mixing Circuit (LIN4/RIN4)

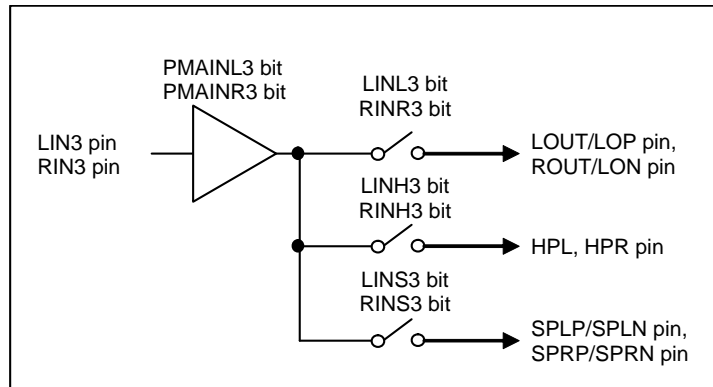

Figure 41. Analog Mixing Circuit (LIN3/RIN3: PLL is not available.)

LOVL bit	LIN2/RIN2/LIN3/RIN3/LIN4/RIN4 → LOUT/ROUT	(default)
0	0dB	
1	+2dB	

Table 42. LIN2/RIN2/LIN3/RIN3/LIN4/RIN4 Input → LOUT/ROUT Output Gain (typ.)

LOVL bit	LIN2/RIN2/LIN3/RIN3/LIN4/RIN4 → LOP/LON	(default)
0	0dB	
1	+2dB	

Table 43. LIN2/RIN2/LIN3/RIN3/LIN4/RIN4 Input → LOP/LON Output Gain (typ.)

HPG bit Setting	LIN2/RIN2/LIN3/RIN3/LIN4/RIN4 → HPL/HPR	(default)
0dB	0dB	

Table 44. LIN2/RIN2/LIN3/RIN3/LIN4/RIN4 Input → Headphone-Amp Output Gain (typ.)

SPKG2-0 bits	LIN2/RIN2/LIN3/RIN3/LIN4/RIN4 → SPLP/SPLN or SPRP/SPRN			
	ALC bit = "0"		ALC bit = "1"	
	SPKMN bit = "1"	SPKMN bit = "0"	SPKMN bit = "1"	SPKMN bit = "0"
000	-1.59dB	+4.41dB	+0.41dB	+6.41dB
001	+0.41dB	+6.41dB	+2.41dB	+8.41dB
010	+4.63dB	+10.63dB	+6.63dB	+12.63dB
011	+6.63dB	+12.63dB	+8.63dB	+14.63dB
100	-6dB	0dB	-4dB	+2dB
101	-12dB	-6dB	-10dB	-4dB
110	N/A	N/A	N/A	N/A
111	N/A	N/A	N/A	N/A

Table 45. LIN2/RIN2/LIN3/RIN3/LIN4/RIN4 Input → Speaker-Amp Output Gain (typ.), N/A: Not available

■ Analog Mixing: Full-differential Mono Input (L4DIF bit = "1": IN4+/IN4- pins)

When L4DIF bit = "1", LIN4 and RIN4 pins become IN4+ and IN4- pins, respectively.

When PMAINL4 bit = "1", IN4+ and IN4- pins can be used as full-differential mono line input for analog mixing. When the LINS4 and RINS4 bits are set to "1", the input signal from the IN4+/IN4- pins is output to Speaker-Amp. When the LINH4 and RINH4 bits are set to "1", the input signal from the IN4+/IN4- pins is output to Headphone-Amp. When the LINL4/RINR4 bits are set to "1", the input signal from the IN4+/IN4- pins is output to the stereo line output amplifier.

Table 46, Table 47, Table 48, and Table 49 show the typical gain. Input signal amplitude is defined as (IN4+) – (IN4-).

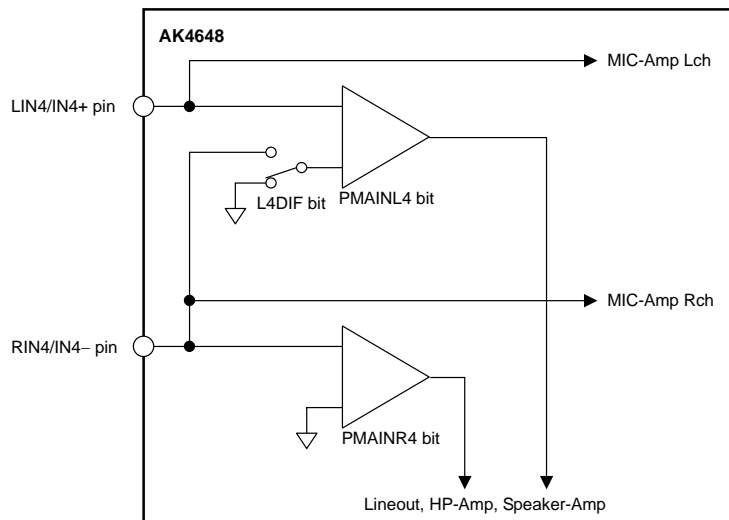

Figure 42. Full-differential Mono Analog Mixing Circuit

LOVL bit	IN4+/IN4- → LOU/ROU
0	-6dB
1	-4dB

Table 46. IN4+/IN4- Input → LOU/ROU Output Gain (typ.)

LOVL bit	IN4+/IN4- → LOP/LON
0	0dB
1	+2dB

Table 47. IN4+/IN4- Input → LOP/LON Output Gain (typ.)

HPG bit Setting	IN4+/IN4- → HPL/HPR
0dB	-6dB

(default)

Table 48. IN4+/IN4- Input → Headphone-Amp Output Gain (typ.)

SPKG2-0 bits	IN4+/IN4- → SPLP/SPLN or SPRP/SPRN	
	ALC bit = "0"	ALC bit = "1"
000	-1.59dB	+0.41dB
001	+0.41dB	+2.41dB
010	+4.63dB	+6.63dB
011	+6.63dB	+8.63dB
100	-6dB	-4dB
101	-12dB	-10dB
110	N/A	N/A
111	N/A	N/A

(default)

Table 49. IN4+/IN4- Input → Speaker-Amp Output Gain (typ.), N/A: Not available

■ Analog Mixing: Mono Input (AIN3 bit = "0": MIN pin)

When AIN3 bit = "0", MIN pin is used as mono input for analog mixing. When the PMMIN bit is set to "1", the mono input is powered-up. When the MINS bit is set to "1", the input signal from the MIN pin is output to Speaker-Amp. When the MINH bit is set to "1", the input signal from the MIN pin is output from Headphone-Amp. When the MINL bit is set to "1", the input signal from the MIN pin is output from the stereo line output amplifier. The external resistor R_i adjusts the signal level of MIN input. Table 50, Table 51, Table 52, and Table 53 show the typical gain example at $R_i = 20k\Omega$. This gain is in inverse proportion to R_i .

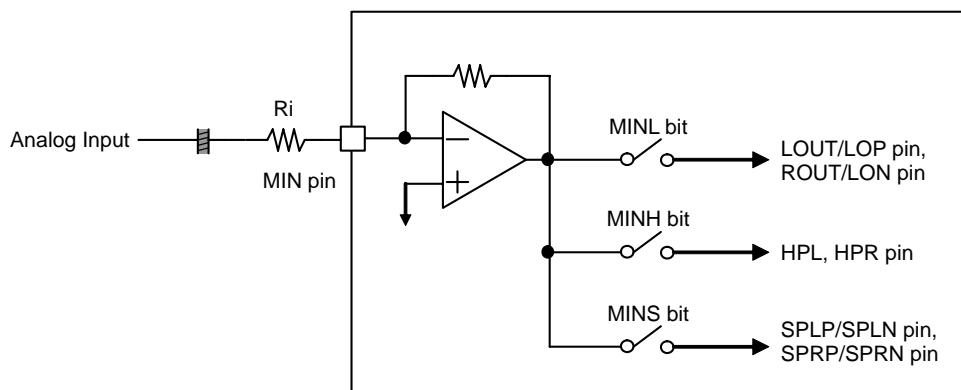

Figure 43. Block Diagram of MIN pin

LOVL bit	MIN → LOUT/ROUT
0	0dB
1	+2dB

(default)

 Table 50. MIN Input → LOUT/ROUT Output Gain (typ.) at $R_i = 20k\Omega$

LOVL bit	MIN → LOP/LON
0	+6dB
1	+8dB

(default)

 Table 51. MIN Input → LON/LOP Output Gain (typ.) at $R_i = 20k\Omega$

HPG bit Setting	MIN → HPL/HPR
0dB	-20dB

 Table 52. MIN Input → Headphone-Amp Output Gain (typ.) at $R_i = 20k\Omega$

SPKG2-0 bits	MIN → SPLP/SPLN or SPRP/SPRN		(default)
	ALC bit = "0"	ALC bit = "1"	
000	+4.43dB	+6.43dB	
001	+6.43dB	+8.43dB	
010	+10.65dB	+12.65dB	
011	+12.65dB	+14.65dB	
100	0dB	+2dB	
101	-6dB	-4dB	
110	N/A	N/A	
111	N/A	N/A	

 Table 53. MIN Input → Speaker-Amp Output Gain (typ.) at $R_i = 20k\Omega$; N/A: Not available

■ Stereo Line Output (LOUT/ROUT pins)

When the LODIF bit is set to "0", the LOUT/ROUT pins become stereo line mode. When DACL bit is "1", Lch/Rch signal of DAC is output from the LOUT/ROUT pins which is single-ended. When DACL bit is "0", output signal is muted and LOUT/ROUT pins output VCOM voltage. The load impedance is $10k\Omega$ (min.). When the PMLO=LOPS bits = "0", the stereo line output enters power-down mode and the output is pulled-down to VSS1 by $100k\Omega$ (typ.). When the LOPS bit is "1", stereo line output enters power-save mode. Pop noise at power-up/down can be reduced by changing PMLO bit at LOPS bit = "1". In this case, output signal line should be pulled-down to VSS1 by $20k\Omega$ after AC coupled as Figure 45. Rise/Fall time is 300ms(max.) at $C=1\mu F$ and $AVDD=3.3V$. When PMLO bit = "1" and LOPS bits = "0", stereo line output is in normal operation.

LOVL bit set the gain of stereo line output.

When LOM bit = "1", DAC output signal is output to LOUT and ROUT pins as (L+R)/2 mono signal.

When LOM3 bit = "1", the signal selected by MICL3 and MICR3 bits (LIN3/RIN3 inputs or MIC-Amp outputs) to LOUT and ROUT pins as (L+R)/2 mono signal.

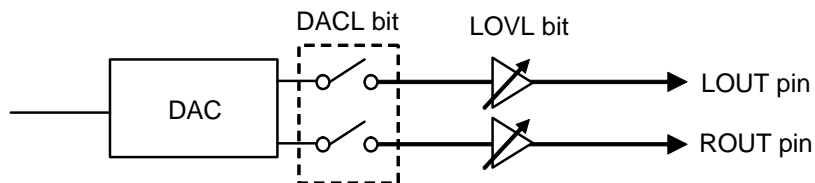

Figure 44. Stereo Line Output

LOPS	PMLO	Mode	LOUT/ROUT pin	(default)
0	0	Power-down	Pull-down to VSS1	
	1	Normal Operation	Normal Operation	
1	0	Power-save	Fall down to VSS1	
	1	Power-save	Rise up to VCOM	

Table 54. Stereo Line Output Mode Select

LOVL	Gain	Output Voltage (typ.)	(default)
0	0dB	$0.6 \times AVDD$	
1	+2dB	$0.757 \times AVDD$	

Table 55. Stereo Line Output Volume Setting

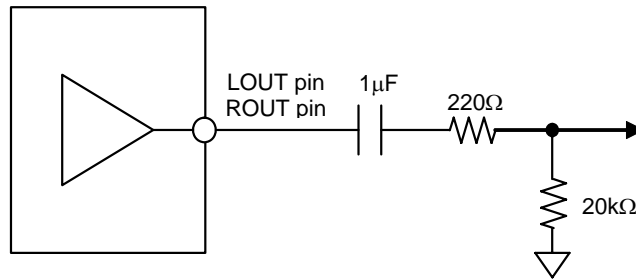

Figure 45. External Circuit for Stereo Line Output (in case of using Pop Reduction Circuit)

<Stereo Line Output Control Sequence (in case of using Pop Reduction Circuit)>

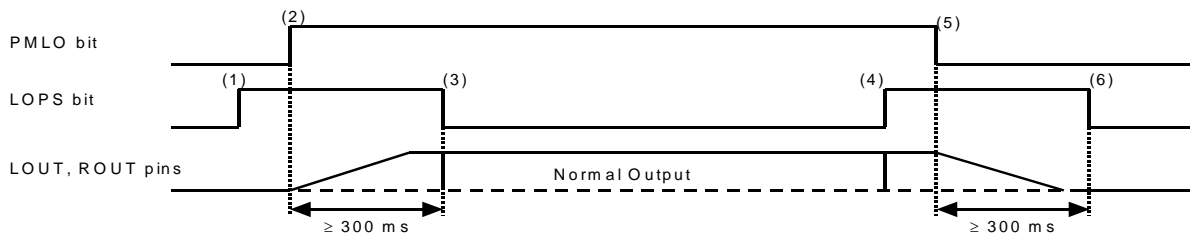
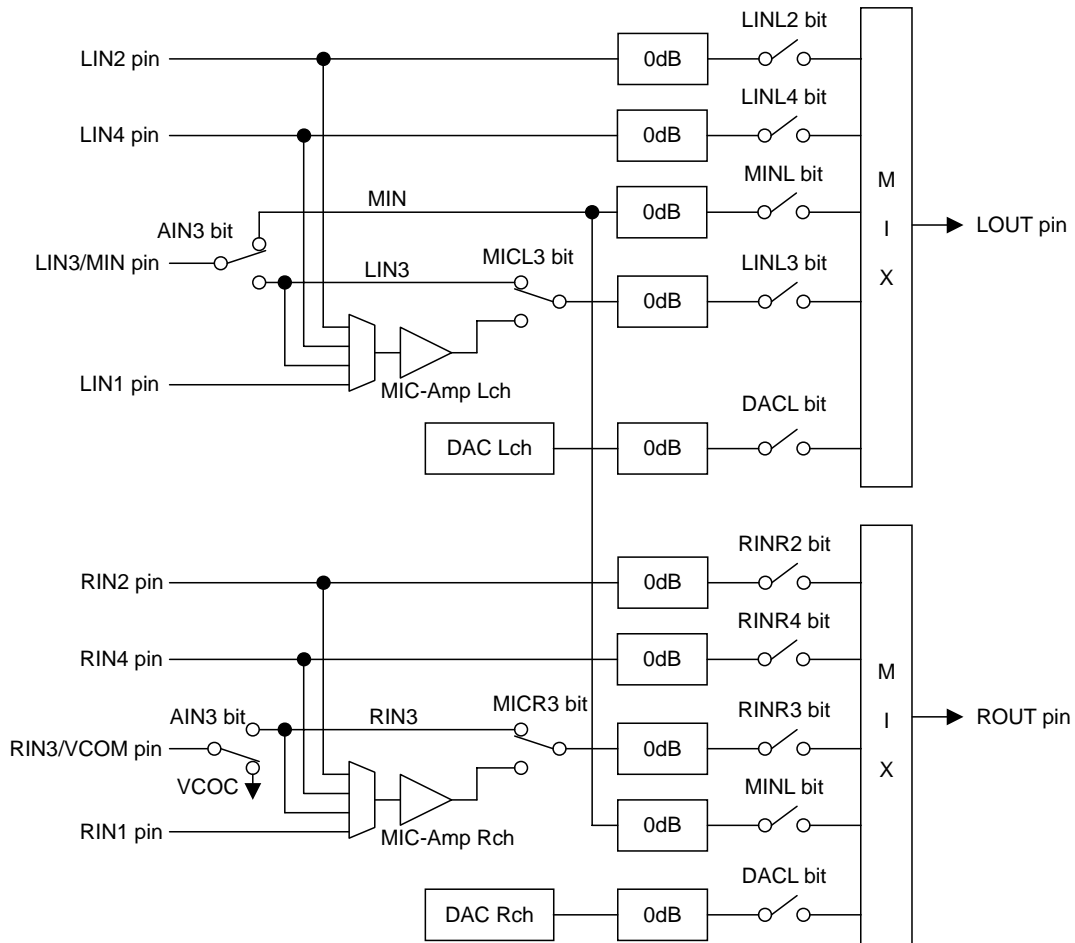

Figure 46. Stereo Line Output Control Sequence (in case of using Pop Reduction Circuit)

- (1) Set LOPS bit = "1". Stereo line output enters the power-save mode.
- (2) Set PMLO bit = "1". Stereo line output exits the power-down mode.
LOUT and ROUT pins rise up to VCOM voltage. Rise time is 200ms (max. 300ms) at $C=1\mu\text{F}$ and $\text{AVDD}=3.3\text{V}$.
- (3) Set LOPS bit = "0" after LOUT and ROUT pins rise up. Stereo line output exits the power-save mode.
Stereo line output is enabled.
- (4) Set LOPS bit = "1". Stereo line output enters power-save mode.
- (5) Set PMLO bit = "0". Stereo line output enters power-down mode.
LOUT and ROUT pins fall down to VSS1. Fall time is 200ms (max. 300ms) at $C=1\mu\text{F}$ and $\text{AVDD}=3.3\text{V}$.
- (6) Set LOPS bit = "0" after LOUT and ROUT pins fall down. Stereo line output exits the power-save mode.

<Analog Mixing Circuit for Stereo Line Output>

DACL, MINL, LINL2, RINR2, LINL3, RINR3, LINL4, RINR4, MICL3, and MICR3 bits control each path switch. MIN path mixing gain is 0dB(typ.)@LOVL bit = "0" when AIN3 bit is "0" and the external input resistance is 20kΩ. LIN2, RIN2, LIN3, RIN3, LIN4, RIN4 and DAC paths mixing gain is 0dB(typ.)@LOVL bit = "0".



Note: When MICL3 bit is set to "1", MIN path is not available.
 Figure 47. Stereo line output Mixing Circuit (LOVL bit = "0")

■ Full-differential Mono Line Output (LOP/LON pins)

When LODIF bit = “1”, LOUT/ROUT pins become LOP/LON pins, respectively. Lch/Rch signal of DAC or LIN2/RIN2/LIN3/RIN3/LIN4/RIN4 is output from the LOP/LON pins which is full-differential as $(L+R)/2$ signal. The load impedance is 10kΩ (min.) for LOP and LON pins, respectively. When the PMLO bit = “0”, the mono line output enters power-down mode and the output is Hi-Z. When the PMLO bit is “1” and LOPS bit is “1”, mono line output enters power-save mode. Pop noise at power-up/down can be reduced by changing PMLO bit at LOPS bit = “0”. When PMLO bit = “1” and LOPS bit = “0”, mono line output enters in normal operation. LOVL bit set the gain of mono line output.

When L4DIF=LODIF bits = “1”, full-differential output signal is as follows: $(LOP) - (LON) = (IN4+) - (IN4-)$.

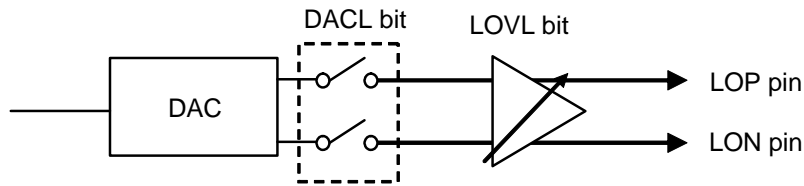

Figure 48. Mono Line Output

PMLO	LOPS	Mode	LOP	LON	
0	x	Power-down	Hi-Z	Hi-Z	(default)
1	1	Power-save	Hi-Z	VCOM	
	0	Normal Operation	Normal Operation	Normal Operation	

Table 56. Mono Line Output Mode Setting (x: Don't care)

LOVL	Gain	Output Voltage (typ.)	
0	+6dB	1.2 x AVDD	(default)
1	+8dB	1.5 x AVDD	

Table 57. Mono Line Output Volume Setting

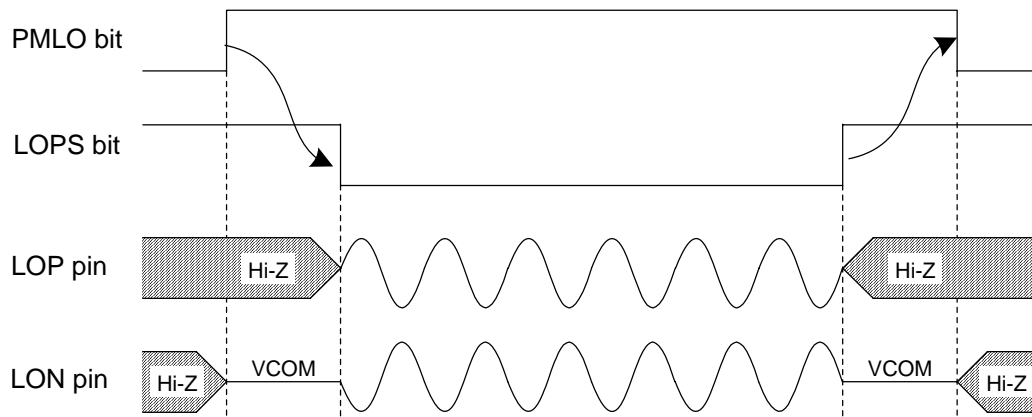
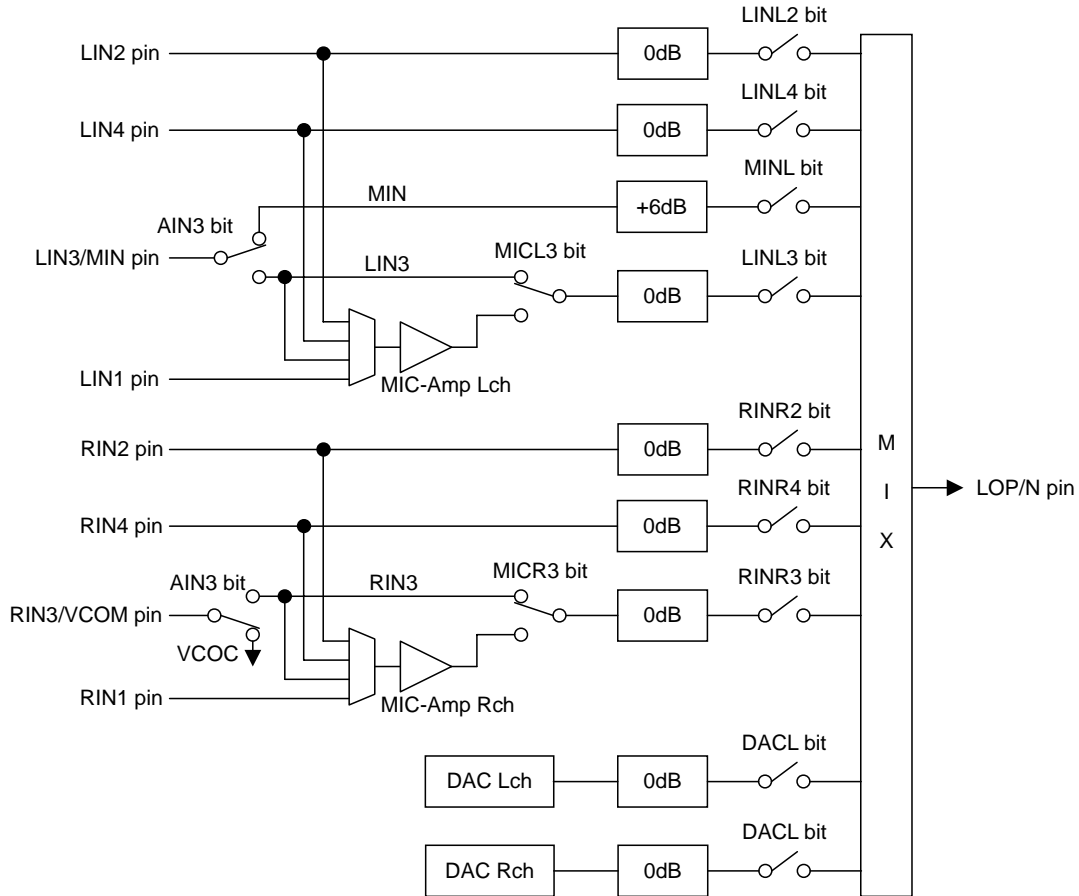

Figure 49. Power-up/Power-down Timing for Mono Line Output

<Analog Mixing Circuit for Mono Line Output>

DACL, MINL, LINL2, RINR2, LINL3, RINR3, LINL4, RINR4, MICL3, and MICR3 bits control each path switch. MIN path mixing gain is +6dB(typ.)@LOVL bit = "0" when AIN3 bit is "0" and the external input resistance is 20kΩ. LIN2, RIN2, LIN3, RIN3, LIN4, RIN4 and DAC paths mixing gain is 0dB(typ.)@LOVL bit = "0".



Note: When MICL3 bit is set to "1", MIN path is not available.
 Figure 50. Mono Line Output Mixing Circuit (LOVL bit = "0")

■ Headphone-Amp

Power supply voltage for the Headphone-Amp is supplied from the HVDD pin and centered on the HVDD/2 voltage at VBAT bit = "0". The load resistance is 16Ω (min.). HPG3-0 bits select the output voltage (Table 58).

When HPM bit = "1", DAC output signal is output to HPL and HPR pins as (L+R)/2 mono signal.

When HPM3 bit = "1", the signal selected by MICL3 and MICR3 bits (LIN3/RIN3 inputs or MIC-Amp outputs) to HPL and HPR pins as (L+R)/2 mono signal.

HPG3-0 bits	Volume [dB]
FH-DH	N/A
CH	+3dB
BH	0dB
AH	-3dB
9H	-6dB
8H	-9dB
7H	-12dB
6H	-15dB
5H	-18dB
4H	-21dB
3H	-24dB
2H	-27dB
1H	-30dB
0H	-33dB

(default)

Table 58. Headphone-Amp volume setting (N/A: Not available)

<Connection with Headphone>

The AK4648 can be connected with the headphone as follows.

1. Single-ended Mode (In case of not using common buffer for Headphone-Amp)

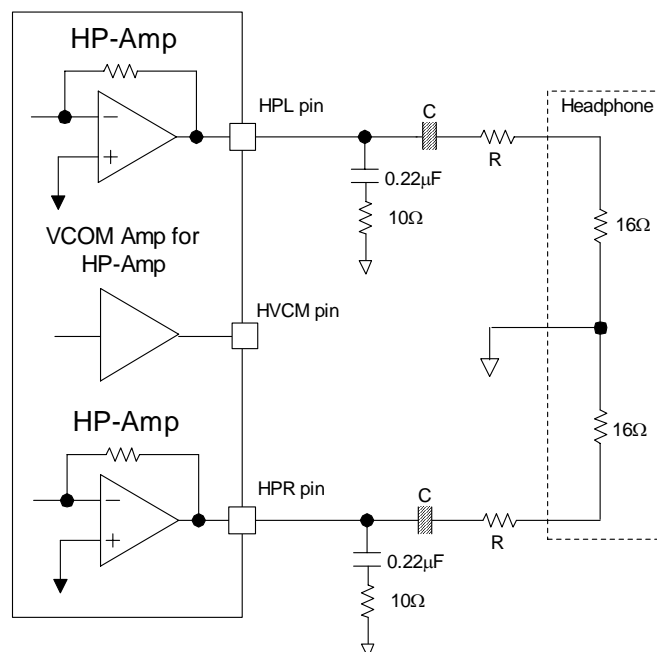

Figure 51. External circuit example of HP-Amp (Single-ended Mode)

When an external resistor R is smaller than 12Ω, put an oscillation prevention circuit (0.22μF±20% capacitor and 10Ω±20% resistor) because it has the possibility that Headphone-Amp oscillates.

The cut-off frequency (fc) of Headphone-Amp depends on the external resistor and capacitor. This fc can be shifted to lower frequency by using 5-band equalizer function. Table 59 shows the cut off frequency and the output power for various resistor/capacitor combinations. The headphone impedance R_L is 16Ω. The output voltage of headphone is typ. (0.6 x AVDD) V_{pp} @HPG = 0dB.

R [Ω]	C [μF]	fc [Hz] 5-band EQ = OFF	fc [Hz] 5-band EQ = ON (+6dB/100Hz @ fs=44.1kHz)	Output Power [mW]@0dBFS		
				HVDD=3.0V AVDD=3.0V	HVDD=3.3V AVDD=3.3V	HVDD=5V AVDD=3.3V
0	220	45	17	25.3	30.6	30.6
	100	100	43			
6.8	100	70	28	12.5	15.1	15.1
	47	149	78			
16	100	50	19	6.3	7.7	7.7
	47	106	47			
	10	137	69			

Note 59. Output power at 16Ω load.

Table 59. External Circuit Example

When the HPMTN bit is “0”, the common voltage of Headphone-Amp falls and the outputs (HPL and HPR pins) go to “L” (VSS2). When the HPMTN bit is “1”, the common voltage rises to HVDD/2 at VBAT bit = “0”. A capacitor between the MUTET pin and ground reduces pop noise at power-up. Rise/Fall time constant is in proportional to HVDD voltage and the capacitor at MUTET pin.

HVDD	Capacitor value of MUTET pin	HPMTN bit= “0” → “1” (Note 60)		HPMTN bit = “1” → “0” (Note 61)	
		typ.	max	typ.	max.
3.6V	1μF±30%	120ms	210ms	140ms	260ms
4.2V		-	230ms	-	270ms
5.0V		-	260ms	-	290ms
3.6V	2.2μF±30%	260ms	460ms	310ms	560ms
4.2V		-	500ms	-	570ms
5.0V		-	550ms	-	590ms

Note 60. Rising time of HP-Amp (0.8 x HVDD/2)

Note 61. Time until the common voltage goes to VSS2.

Table 60. Relationship between capacitor value of MUTET pin and MUTE ON/OFF time (VBAT bit = “0”)

When PMHPL and PMHPR bits are “0”, the Headphone-Amp is powered-down, and HPL and HPR pins go to “L” (VSS2).

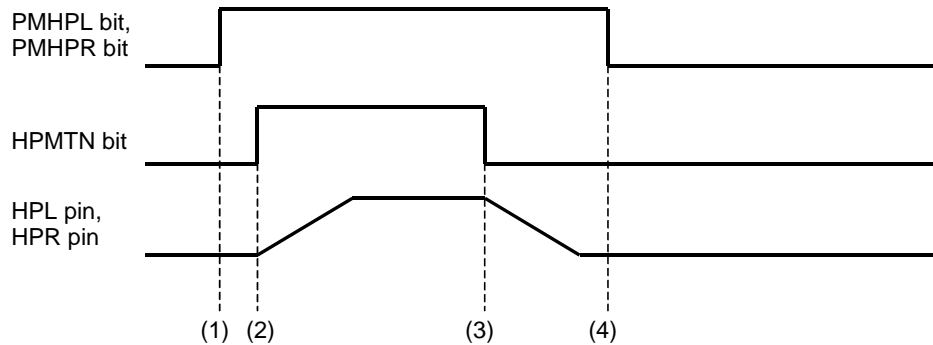

Figure 52. Power-up/down sequence for Headphone-Amp (Single-ended Mode)

- (1) Headphone-Amp power-up (PMHPL, PMHPR bit = “1”). The outputs are still VSS2.
- (2) Headphone-Amp common voltage rises up (HPMTN bit = “1”). Common voltage of Headphone-Amp is rising.
- (3) Headphone-Amp common voltage falls down (HPMTN bit = “0”). Common voltage of Headphone-Amp is falling.
- (4) Headphone-Amp power-down (PMHPL, PMHPR bit = “0”). The outputs are VSS2. If the power supply is switched off or Headphone-Amp is powered-down before the common voltage goes to VSS2, some POP noise occurs.

2. Pseudo Cap-less Mode (In case of using common buffer for Headphone-Amp)

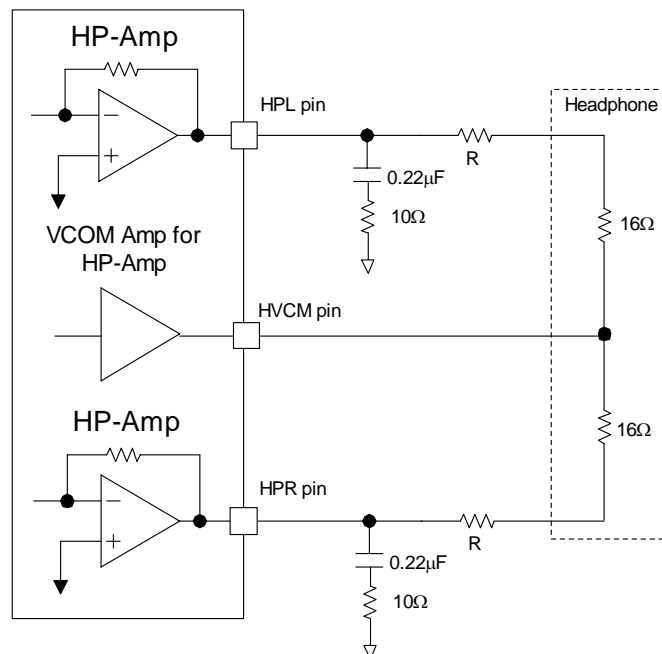

Figure 53. External circuit example for Headphone-Amp (Pseudo Cap-less Mode)

When an external resistor R is smaller than 12Ω, put an oscillation prevention circuit (0.22µF±20% capacitor and 10Ω±20% resistor) because it has the possibility that Headphone-Amp oscillates.

When the HPMTN bit is “0”, common voltages of Headphone-Amp and common buffer for Headphone-Amp fall and HPL, HPR and HVCM pins go to “L” (VSS2). When the HPMTN bit is “1”, the common voltages rises to HVDD/2 at VBAT bit = “0”. A capacitor between the MUTET pin and ground reduces pop noise at power-up. Rise/Fall time constant is in proportional to HVDD voltage and the capacitor at MUTET pin.

HVDD	Capacitor value of MUTET pin	HPMTN bit= “0” → “1” (Note 62)		HPMTN bit = “1” → “0” (Note 63)	
		typ.	max	typ.	max.
3.6V	1μF±30%	120ms	210ms	140ms	260ms
4.2V		-	230ms	-	270ms
5.0V		-	260ms	-	290ms
3.6V	2.2μF±30%	260ms	460ms	310ms	560ms
4.2V		-	500ms	-	570ms
5.0V		-	550ms	-	590ms

Note 62. Rising time of HP-Amp ($0.8 \times HVDD/2$)

Note 63. Time until the common voltage goes to VSS2.

Table 61. Relationship between capacitor value of MUTET pin and MUTE ON/OFF time (VBAT bit = “0”)

When PMHPL, PMHPR, and PMHPC bits are “0”, the Headphone-Amp is powered-down, and HPL, HPR, HVCM pins go to “L” (VSS2).

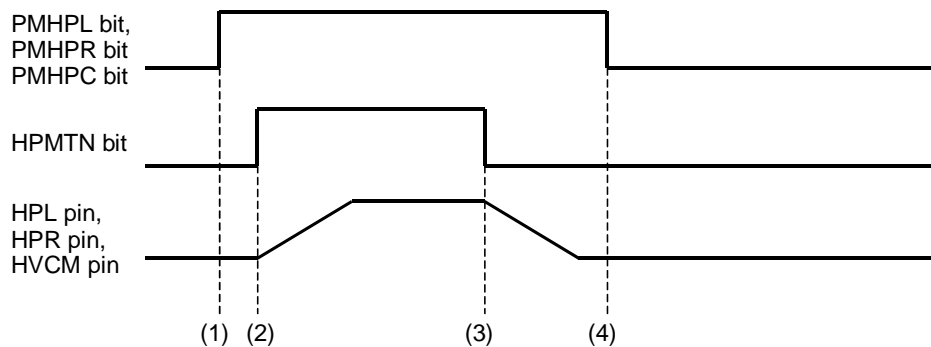

Figure 54. Power-up/down sequence for Headphone-Amp (Pseudo Cap-less Mode)

- (1) Headphone-Amp power-up (PMHPL=PMHPR=PMHPC bits = “1”). Outputs are still VSS2.
- (2) Headphone-Amp common voltage rises up (HPMTN bit = “1”). Common voltage of Headphone-Amp is rising.
- (3) Headphone-Amp common voltage falls down (HPMTN bit = “0”). Common voltage of Headphone-Amp is falling.
- (4) Headphone-Amp power-down (PMHPL=PMHPR=PMHPC bits = “0”). Outputs become VSS2. If the power supply is switched off or Headphone-Amp is powered-down before the common voltage goes to VSS2, some POP noise occurs.

<Headphone-Amp PSRR>

When HVDD is directly supplied from the battery in the mobile phone system, RF noise may influences headphone output performance. When VBAT bit is set to “1”, HP-Amp PSRR for the noise applied to HVDD is improved. In this case, HP-Amp common voltage is $0.64 \times AVDD$ (typ.). When AVDD is 3.3V, common voltage is 2.1V. Therefore, when HVDD voltage becomes lower than 4.2V, the output signal will be clipped.

VBAT bit	0	1
Common Voltage [V]	$0.5 \times HVDD$	$0.64 \times AVDD$

Table 62. HP-Amp Common Voltage

<Wired OR with External Headphone-Amp>

When PMVCM=PMHPL=PMHPR bits = “0” and HPZ bit = “1”, Headphone-Amp is powered-down and HPL/R pins are pulled-down to VSS2 by 200kΩ (typ.). In this setting, it is available to connect Headphone-Amp of the AK4648 and external single supply Headphone-Amp by “wired OR” and the output level of external HP-Amp should be from “-0.3V” to “HVDD+0.3V”. In this mode, power supply current is 20μA(typ.). This function is not supported in Pseudo Cap-less Mode.

PMVCM	PMHPL/R	HPMTN	HPZ	Mode	HPL/R pins
x	0	x	0	Power-down & Mute	VSS2
0	0	x	1	Power-down	Pull-down by 200kΩ
1	1	0	x	Mute	VSS2
1	1	1	x	Normal Operation	Normal Operation

(default)

Table 63. HP-Amp Mode Setting (x: Don't care)

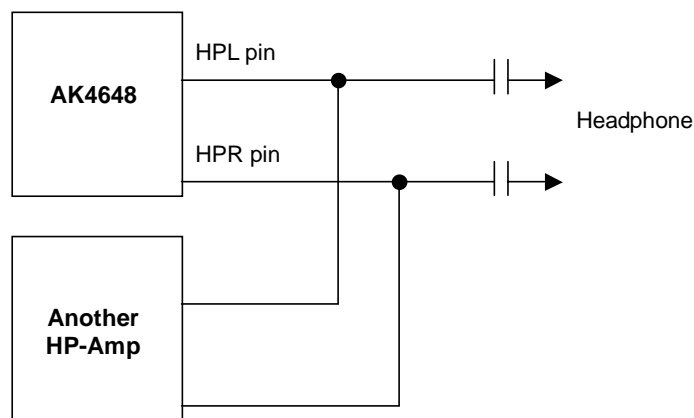

Figure 55. Wired OR with External Headphone-Amp

<Connection with mono headphone>

The AK4648 can be connected with mono headphone by using Headphone-Amp power management bit and HPZ bit. As right channel of mono headphone is usually connected to GND, the right channel of Headphone-Amp must be Hi-Z. Here are the power up sequence in Single-ended Mode and Pseudo Cap-less Mode.

1. Single-ended Mode

- (1) Power-down Headphone-amp: PMHPL=PMHPR=HPZ bits = "0"
HPL/HPR pins output VSS2.
- (2) Power-up left channel of Headphone-amp: PMHPL = "1"
Left channel of Headphone-amp is powered-up and HPL pin outputs VSS2.
- (3) Change pull-down resistor of right channel of Headphone-amp: HPZ bit = "1"
HPR pin is pulled-down by 200k Ω (typ.) to VSS2.
- (4) Release mute of Headphone-amp: HPMTN bit: "0" \rightarrow 1
HPL pin outputs the signal and HPR pin is pulled-down by 200k Ω (typ.) to VSS2.

2. Pseudo Cap-less Mode

- (1) Power-down of Headphone-amp: PMHPL=PMHPR=PMHPC=HPZ bits = "0"
HPL/HPR/HVCM pins output VSS2.
- (2) Power-up left channel and common buffer of Headphone-amp: PMHPL = PMHPC bits = "1"
Left channel and common buffer of Headphone-amp are powered-up and they output VSS2.
- (3) Change pull-down resistor of right channel of Headphone-amp: HPZ bit = "1"
HPR pin is pulled-down by 200k Ω (typ.) to VSS2.
- (4) Release mute of Headphone-amp: HPMTN bit: "0" \rightarrow 1
HPL pin outputs the signal. HPR pin is pulled-down by 200k Ω (typ.) to VSS2 and outputs HVCM voltage.

<Analog Mixing Circuit for Headphone Output>

DACH, MINH, LINH2, RINH2, LINH3, RINH3, LINH4, RINH4, MICL3, and MICR3 bits control each path switch. MIN path mixing gain is $-20\text{dB}(\text{typ.})$ @ $\text{HPG} = 0\text{dB}$ when AIN3 bit is "0" and the external input resistance is $20\text{k}\Omega$. DACH, LIN2, RIN2, LIN3, RIN3, LIN4, RIN4 and DAC paths mixing gain is $0\text{dB}(\text{typ.})$ @ $\text{HPG} = 0\text{dB}$.

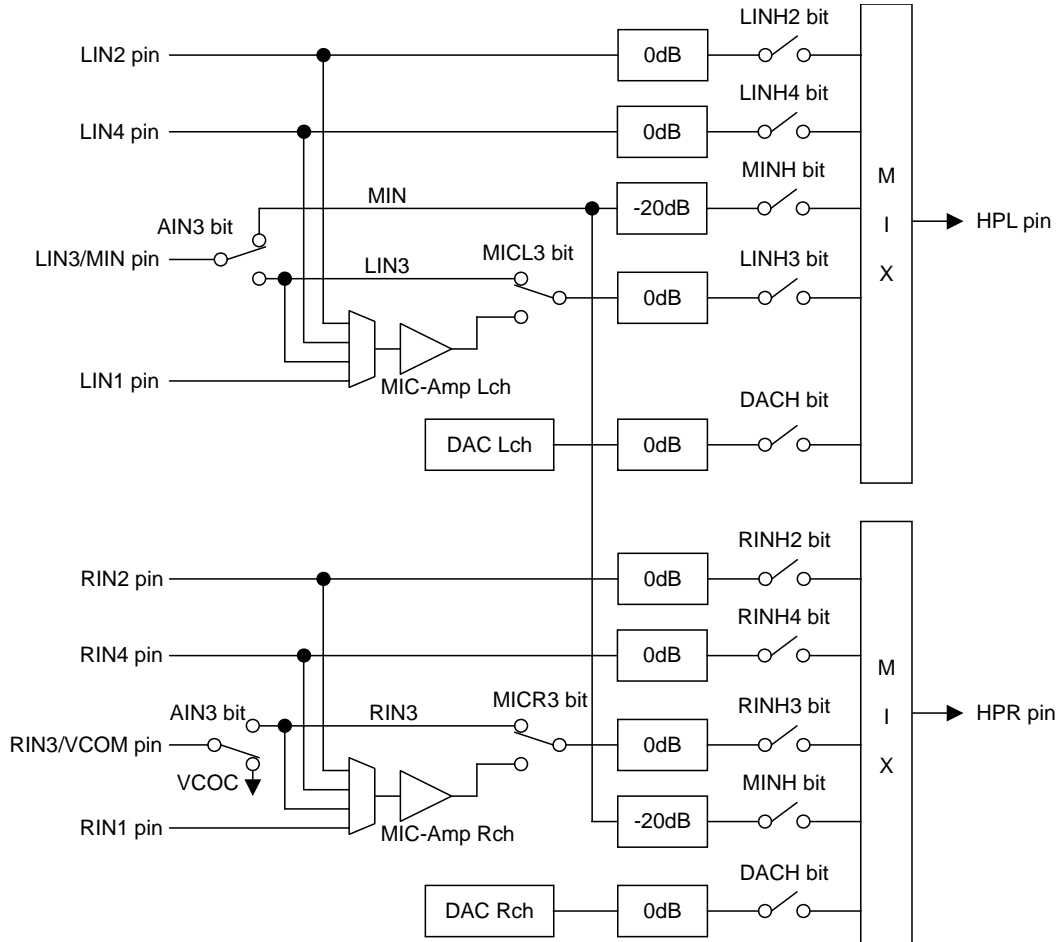

Note: When MICL3 bit is set to "1", MIN path is not available.
 Figure 56. Headphone Output Mixing Circuit (HPG = 0dB)

■ Speaker-Amp

Speaker output mode is selected by SPKMN bit and Power ON/OFF of Speaker-Amp is controlled by PMSPL and PMSPR bits. In Stereo SPK Mode (SPKMN bit = "1", PMSPL=PMSPR bits = "1") and Mono SPK Mode (SPKMN bit = "0", PMSPL bit = "1" or PMSPR bit = "1"), the output power is 640mW/ch at HVDD=3.6V, 8Ω. In High Power Mono SPK Mode (SPKMN bit = "0", PMSPL=PMSPR bit = "1"), the output power is 820mW at HVDD=3.6V, 8Ω. When using High Power Mono SPK mode, SPLP pin should be connected to SPRP pin and SPLN pin should be connected to SPRN pin. When SPKMN bit is changed, PMSPL and PMSPR bits should be set to "0". Power-Save mode is controlled by SPPSN bit.

Mode	SPKMN bit	PMSPL bit	PMSPR bit	SPLP/SPLN pin	SPRP/SPRN pin
Mono SPK	0	0	0	PD	PD
	0	1	0	PU (*1)	PD
	0	0	1	PD	PU (*1)
High Power Mono SPK	0	1	1	PU (*2)	-
Stereo SPK	1	0	0	PD	PD
	1	0	1	PD	PU: Rch
	1	1	0	PU: Lch	PD
	1	1	1	PU: Lch	PU: Rch

*1: The output signal is Mono Mixing [(L+R)/2]. The output power is 640mW at HVDD=3.6V, 8Ω.

*2: The output signal is Mono Mixing [(L+R)/2]. The output power is 820mW at HVDD=3.6V, 8Ω.

Table 64. Speaker Output Mode Setting (PD: Power-Down, PU: Power-Up)

Power supply for Speaker-Amp (HVDD) is 2.6V to 5.0V. The DAC or LIN2/RIN2/LIN3/RIN3/LIN4/RIN4 signal is input to the Speaker-amp as Mono: [(L+R)/2] or stereo signal. The input signal selects Mono or Stereo by using SPKMN bit. The Speaker-amp is mono/stereo with BTL output. The gain is set by SPKG2-0 bits. Output level depends on AVDD voltage and SPKG2-0 bits.

SPKG2-0 bits	Gain		(default)
	ALC bit = "0"	ALC bit = "1"	
000	+4.43dB	+6.43dB	(default)
001	+6.43dB	+8.43dB	
010	+10.65dB	+12.65dB	
011	+12.65dB	+14.65dB	
100	0dB	+2dB	
101	-6dB	-4dB	
110	N/A	N/A	
111	N/A	N/A	

Table 65. SPK-Amp Internal gain (Gain of mono mixing is not included.), N/A: Not available

AVDD	HVDD	SPKG2-0 bits	SPK-Amp Output (DAC Input = 0dBFS)	
			ALC bit = "0"	ALC bit = "1" (LMTH1-0 bits = "00"; -2.5dBFS)
3.3V	3.6V	000	3.30Vpp	3.11Vpp
		001	4.15Vpp	3.92Vpp
		010	5.2Vpp (Note 64)	5.2Vpp (Note 64)
		011	5.2Vpp (Note 64)	5.2Vpp (Note 64)
	4.5V	000	3.30Vpp	3.11Vpp
		001	4.15Vpp	3.92Vpp
		010	6.75Vpp	6.37Vpp
		011	7.0Vpp (Note 64)	7.0Vpp (Note 64)

Note 64. The output level is calculated assuming that output signal is not clipped. In actual case, output signal may be clipped when DAC outputs 0dBFS signal. DAC output level should be set to lower level by setting digital volume so that Speaker-Amp output level is 5.2Vpp (HVDD=3.6V) or 7.0Vpp (HVDD=4.5V) or less and output signal is not clipped.

Table 66. SPK-Amp Output Level

<ALC Operation Example of Speaker Playback>

Register Name	Comment	fs=44.1kHz	
		Data	Operation
LMTH1-0	Limiter detection Level	00	-2.5dBFS
ZELMN	Limiter zero crossing detection	0	Enable
ZTM1-0	Zero crossing timeout period	10	11.6ms
WTM2-0	Recovery waiting period *WTM2-0 bits should be the same data as ZTM1-0 bits	011	23.2ms
REF7-0	Maximum gain at recovery operation	C1H	+18dB
IVL7-0, IVR7-0	Gain of IVOL	91H	0dB
LMAT1-0	Limiter ATT step	00	1 step
RGAIN1-0	Recovery GAIN step	00	1 step
ALC	ALC enable	1	Enable

Table 67. ALC Operation Example of Speaker Playback

<Speaker-Amp Control Sequence>

Lch Speaker-Amp is powered-up/down by PMSPL bit and Rch Speaker-Amp is powered-up/down by PMSPR bit. **Power-save mode of both Lch and Rch Speaker-Amps are controlled by SPPSN bit.**

When PMSPL (PMSPR) bit is “0”, both SPLP (SPRP) and SPLN (SPRN) pin are in Hi-Z state. When PMSPL (PMSPR) bit is “1” and SPPSN bit is “0”, the Speaker-Amp enters power-save mode. In this mode, SPLP (SPRP) pin is placed in Hi-Z state and SPLN (SPRN) pin goes to HVDD/2 voltage. Power-save mode can reduce the pop noise at power-up and power-down.

When The PDN pin is changed from “L” to “H” after power-up and PMSPL (PMSPR) bit is set to “1”, SPLP (SPRP) and SPLN (SPRN) pins are in power-save mode. When changing the output mode of Speaker-Amp, PMSPL and PMSPR bits should be set to “0”.

PMSPL bit PMSPR bit	SPPSN bit	Mode	SPLP pin SPRP pin	SPLN pin SPRN pin	
0	x	Power-down	Hi-Z	Hi-Z	(default)
1	0	Power-Save	Hi-Z	HVDD/2	
	1	Normal Operation	Normal Operation	Normal Operation	

Table 68. Setting of Speaker-Amp Mode (x: Don't care)

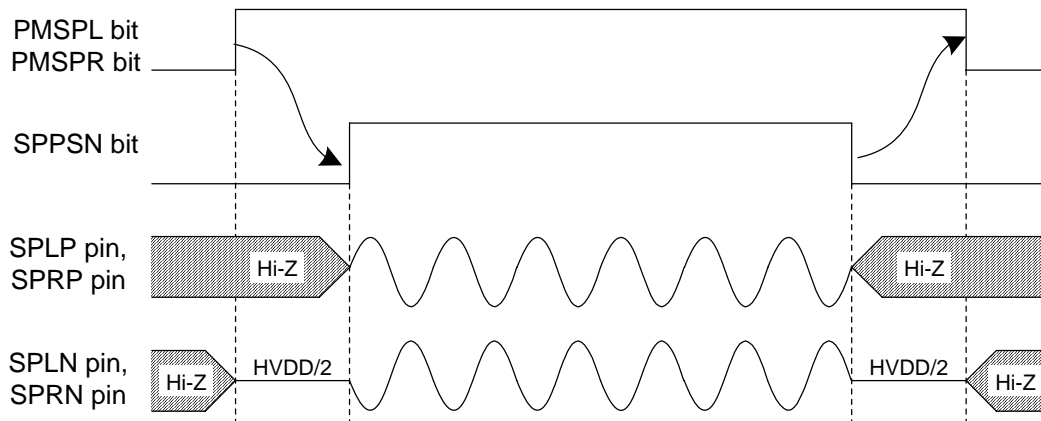
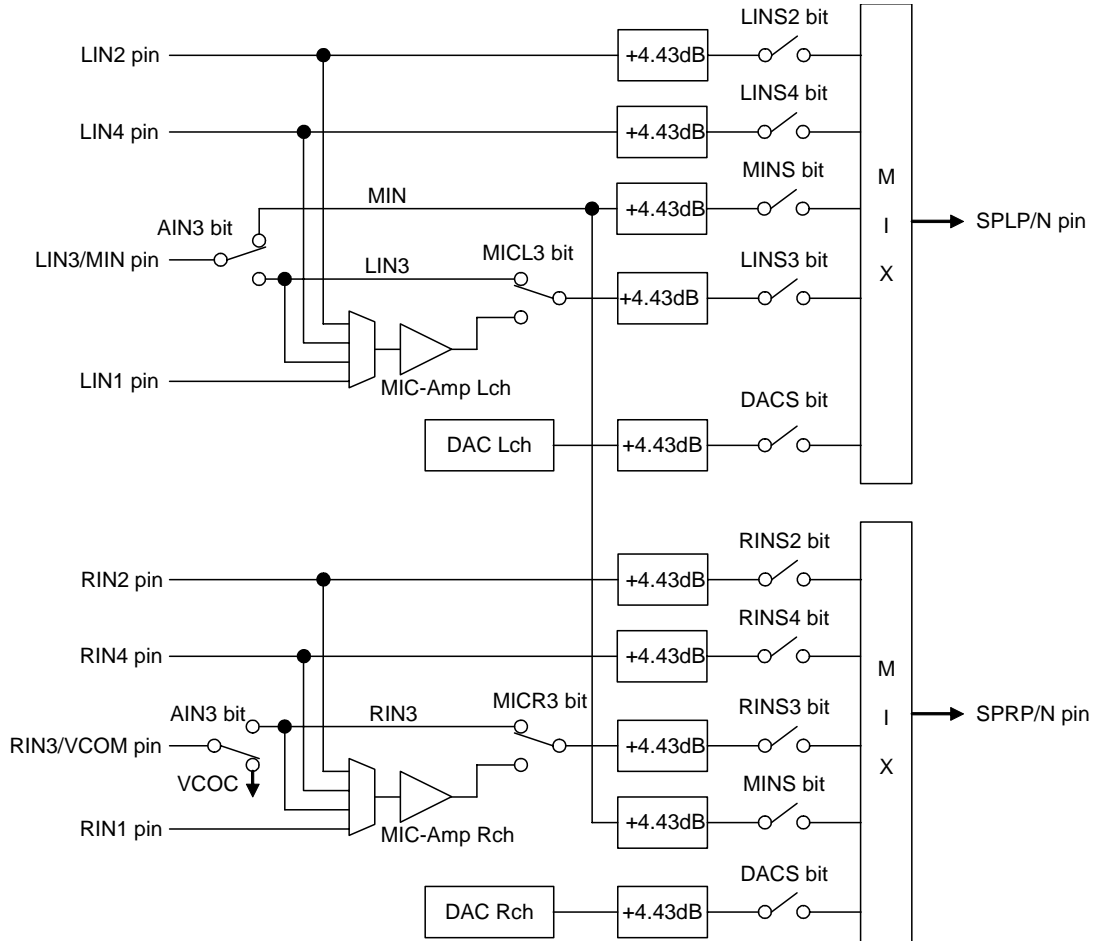

Figure 57. Power-up/Power-down Timing for Speaker-Amp

<Analog Mixing Circuit for Speaker Output>

1. Stereo SPK Mode (SPKMN bit = "1")

DACS, MINS, LINS2, RINS2, LINS3, RINS3, LINS4, RINS4, MICL3, and MICR3 bits control each path switch. MIN path mixing gain is +4.43dB(typ.) @ SPKG2-0 bits = "000" & ALC bit = "0" when AIN3 bit is "0" and the external input resistance is 20kΩ. DACS, LINS2, RINS2, LINS3, RINS3, LINS4, and RINS4 paths mixing gain is +4.43(typ.) @ SPKG2-0 bits = "000" & ALC bit = "0".



Note: When MICL3 bit is set to "1", MIN path is not available.

Figure 58. Speaker Mixing Circuit (SPKMN bit = "1", SPKG2-0 bits = "000", ALC bit = "0")

2. Mono SPK Mode & High Power Mono SPK Mode (SPKMN bit = "0")

DACS, MINS, LINS2, RINS2, LINS3, RINS3, LINS4, RINS4, MICL3, and MICR3 bits control each path switch. MIN path mixing gain is +4.43dB(typ.)@SPKG2-0 bits = "000" & ALC bit = "0" when AIN3 bit is "0" and the external input resistance is 20kΩ. DACS, LINS2, RINS2, LINS3, RINS3, LINS4, RINS4, MICL3, and MICR3 paths mixing gain is -1.59dB(typ.) @ SPKG2-0 bits = "000" & ALC bit = "0".

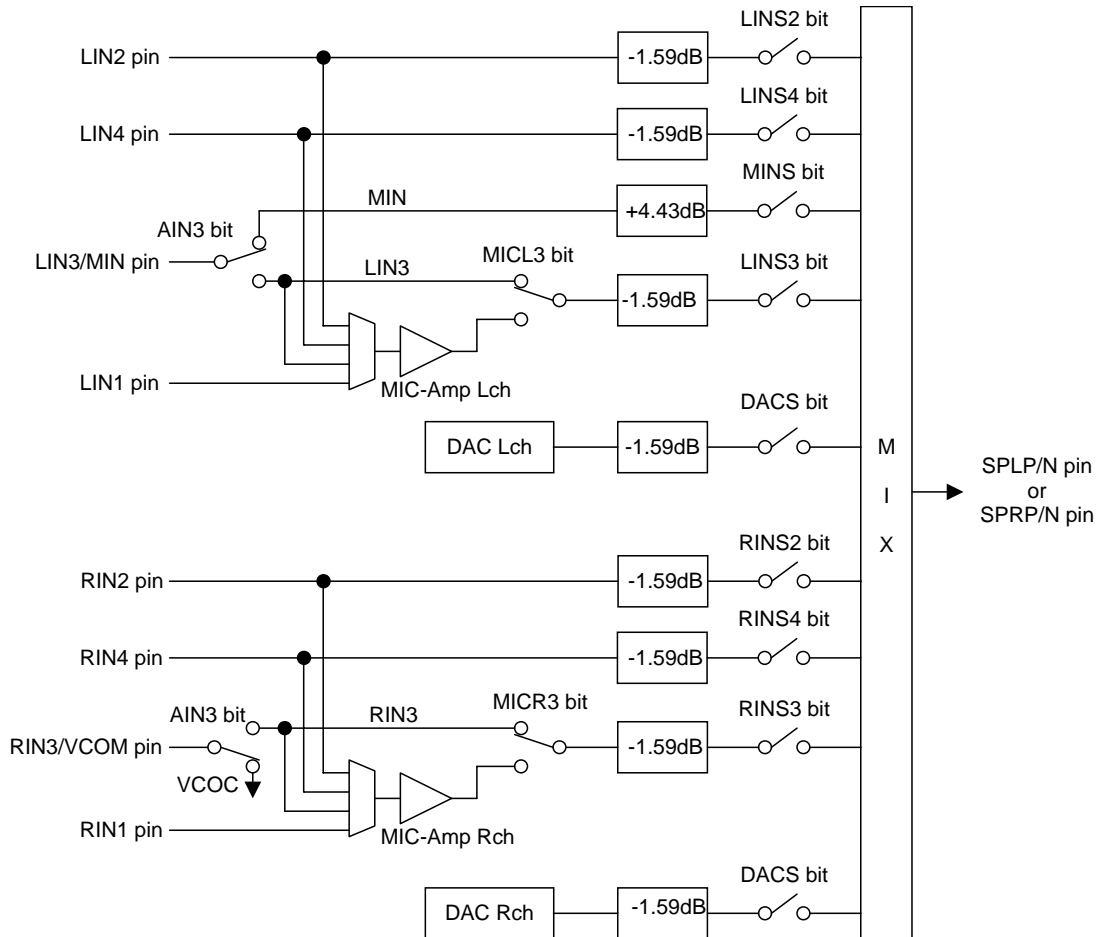

Note: When MICL3 bit is set to "1", MIN path is not available.

Figure 59. Speaker Mixing Circuit (SPKMN bit = "0", SPKG2-0 bits = "000", ALC bit = "0")

Serial Control Interface

The AK4648 supports the fast-mode I²C-bus (max.: 400kHz). Pull-up resistors at SDA and SCL pins should be connected to (TVDD+0.3) V or less voltage.

1. WRITE Operations

Figure 60 shows the data transfer sequence for the I²C-bus mode. All commands are preceded by a START condition. A HIGH to LOW transition on the SDA line while SCL is HIGH indicates a START condition (Figure 66). After the START condition, a slave address is sent. This address is 7 bits long followed by the eighth bit that is a data direction bit (R/W). The most significant six bits of the slave address are fixed as “001001”. The next bit is CAD0 (device address bit). This bit identifies the specific device on the bus. The hard-wired input pin (CAD0 pin) sets these device address bits (Figure 61). If the slave address matches that of the AK4648, the AK4648 generates an acknowledge and the operation is executed. The master must generate the acknowledge-related clock pulse and release the SDA line (HIGH) during the acknowledge clock pulse (Figure 67). A R/W bit value of “1” indicates that the read operation is to be executed. A “0” indicates that the write operation is to be executed.

The second byte consists of the control register address of the AK4648. The format is MSB first, and those most significant 2-bits are fixed to zeros (Figure 62). The data after the second byte contains control data. The format is MSB first, 8bits (Figure 63). The AK4648 generates an acknowledge after each byte has been received. A data transfer is always terminated by a STOP condition generated by the master. A LOW to HIGH transition on the SDA line while SCL is HIGH defines a STOP condition (Figure 66).

The AK4648 can perform more than one byte write operation per sequence. After receiving the third byte the AK4648 generates an acknowledge and awaits the next data. The master can transmit more than one byte instead of terminating the write cycle after the first data byte is transferred. After receiving each data packet the internal 6-bit address counter is incremented by one, and the next data is automatically taken into the next address. If the address exceeds 27H prior to generating a stop condition, the address counter will “roll over” to 00H and the previous data will be overwritten.

The data on the SDA line must remain stable during the HIGH period of the clock. The HIGH or LOW state of the data line can only change when the clock signal on the SCL line is LOW (Figure 68) except for the START and STOP conditions.

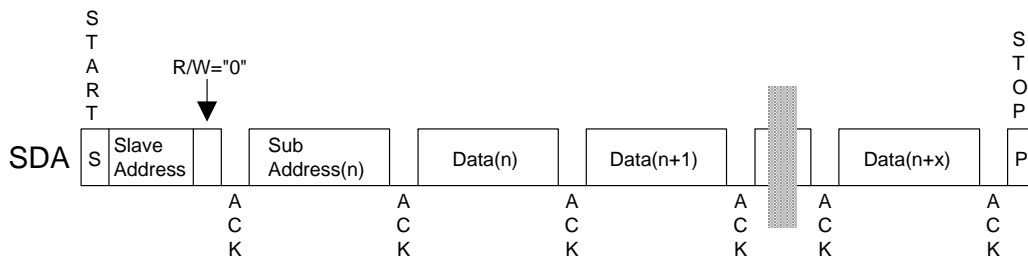
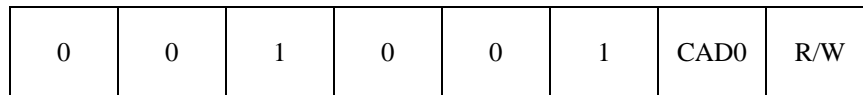

Figure 60. Data Transfer Sequence at the I²C-Bus Mode



(The CAD0 should match with CAD0 pin)

Figure 61. The First Byte

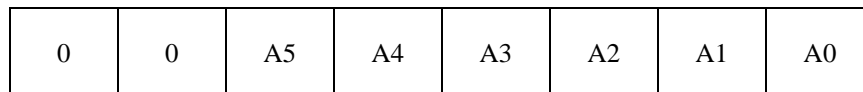

Figure 62. The Second Byte

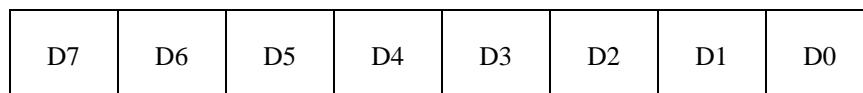

Figure 63. Byte Structure after the second byte

2. READ Operations

Set the R/W bit = "1" for the READ operation of the AK4648. After transmission of data, the master can read the next address's data by generating an acknowledge instead of terminating the write cycle after receiving the first data word. After receiving each data packet the internal 6-bit address counter is incremented, and the next data is automatically taken into the next address. If the address exceeds 27H prior to generating a stop condition, the address counter will "roll over" to 00H and the data of 00H will be read out.

The AK4648 supports two basic read operations: CURRENT ADDRESS READ and RANDOM ADDRESS READ.

2-1. CURRENT ADDRESS READ

The AK4648 contains an internal address counter that maintains the address of the last word accessed, incremented by one. Therefore, if the last access (either a read or write) were to address n, the next CURRENT READ operation would access data from the address n+1. After receiving the slave address with R/W bit set to "1", the AK4648 generates an acknowledge, transmits 1-byte of data to the address set by the internal address counter and increments the internal address counter by 1. If the master does not generate an acknowledge but instead generates a stop condition, the AK4648 ceases transmission.

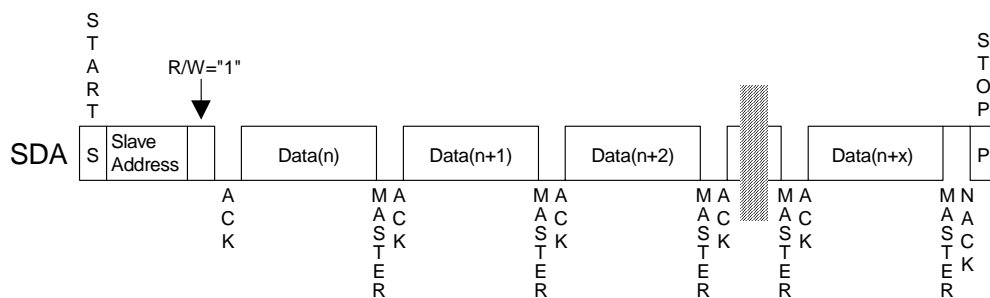

Figure 64. CURRENT ADDRESS READ

2-2. RANDOM ADDRESS READ

The random read operation allows the master to access any memory location at random. Prior to issuing the slave address with the R/W bit set to "1", the master must first perform a "dummy" write operation. The master issues a start request, a slave address (R/W bit = "0") and then the register address to read. After the register address is acknowledged, the master immediately reissues the start request and the slave address with the R/W bit set to "1". The AK4648 then generates an acknowledge, 1 byte of data and increments the internal address counter by 1. If the master does not generate an acknowledge to the data but instead generates a stop condition, the AK4648 ceases transmission.

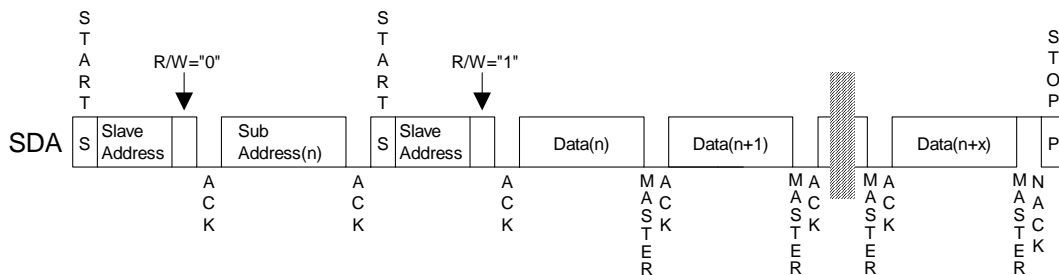

Figure 65. RANDOM ADDRESS READ

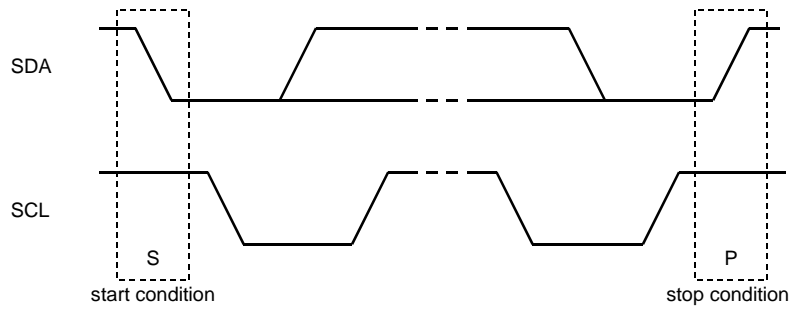

Figure 66. START and STOP Conditions

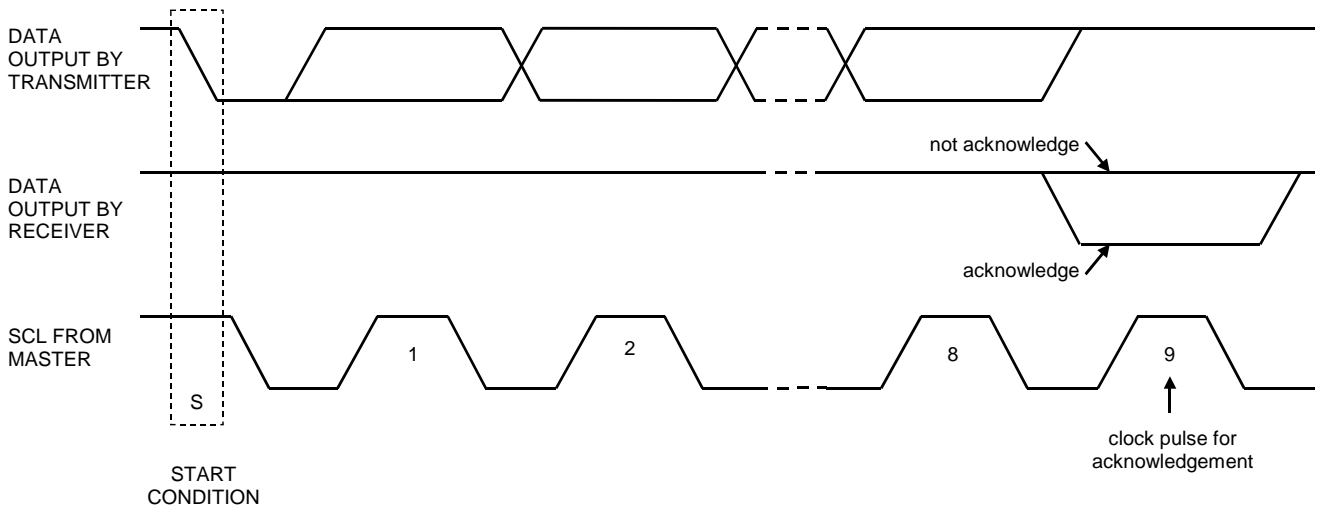

Figure 67. Acknowledge on the I²C-Bus

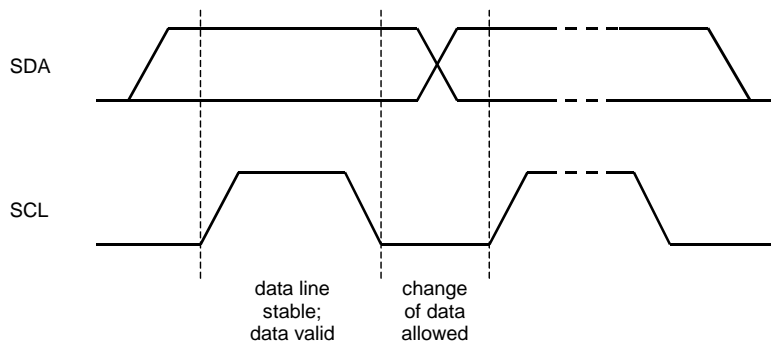

Figure 68. Bit Transfer on the I²C-Bus

■ Register Map

Addr	Register Name	D7	D6	D5	D4	D3	D2	D1	D0
00H	Power Management 1	PMSPR	PMVCM	PMMIN	PMSPL	PMLO	PMDAC	0	PMADL
01H	Power Management 2	HPZ	HPMTN	PMHPL	PMHPR	M/S	PMHPC	MCKO	PMPLL
02H	Signal Select 1	SPPSN	MINS	DACS	DACL	0	PMMP	0	MGAIN0
03H	Signal Select 2	LOVL	LOPS	MGAIN1	SPKG1	SPKG0	MINL	SPKG2	0
04H	Mode Control 1	PLL3	PLL2	PLL1	PLL0	BCKO	0	DIF1	DIF0
05H	Mode Control 2	PS1	PS0	FS3	MSBS	BCKP	FS2	FS1	FS0
06H	Timer Select	DVTM	WTM2	ZTM1	ZTM0	WTM1	WTM0	RFST1	RFST0
07H	ALC Mode Control 1	0	0	ALC	ZELMN	LMAT1	LMAT0	RGAIN0	LMTH0
08H	ALC Mode Control 2	REF7	REF6	REF5	REF4	REF3	REF2	REF1	REF0
09H	Lch Input Volume Control	IVL7	IVL6	IVL5	IVL4	IVL3	IVL2	IVL1	IVL0
0AH	Lch Digital Volume Control	DVL7	DVL6	DVL5	DVL4	DVL3	DVL2	DVL1	DVL0
0BH	ALC Mode Control 3	RGAIN1	LMTH1	0	0	0	0	VBAT	0
0CH	Rch Input Volume Control	IVR7	IVR6	IVR5	IVR4	IVR3	IVR2	IVR1	IVR0
0DH	Rch Digital Volume Control	DVR7	DVR6	DVR5	DVR4	DVR3	DVR2	DVR1	DVR0
0EH	Mode Control 3	0	LOOP	SMUTE	DVOLC	0	FBEQ	DEM1	DEM0
0FH	Mode Control 4	HPG3	HPG2	HPG1	HPG0	IVOLC	HPM	MINH	DACH
10H	Power Management 3	INR1	INL1	0	MDIF2	MDIF1	INR0	INL0	PMADR
11H	Digital Filter Select	GN1	GN0	0	FIL1	EQ	FIL3	0	0
12H	FIL3 Co-efficient 0	F3A7	F3A6	F3A5	F3A4	F3A3	F3A2	F3A1	F3A0
13H	FIL3 Co-efficient 1	F3AS	0	F3A13	F3A12	F3A11	F3A10	F3A9	F3A8
14H	FIL3 Co-efficient 2	F3B7	F3B6	F3B5	F3B4	F3B3	F3B2	F3B1	F3B0
15H	FIL3 Co-efficient 3	0	0	F3B13	F3B12	F3B11	F3B10	F3B9	F3B8
16H	EQ Co-efficient 0	EQA7	EQA6	EQA5	EQA4	EQA3	EQA2	EQA1	EQA0
17H	EQ Co-efficient 1	EQA15	EQA14	EQA13	EQA12	EQA11	EQA10	EQA9	EQA8
18H	EQ Co-efficient 2	EQB7	EQB6	EQB5	EQB4	EQB3	EQB2	EQB1	EQB0
19H	EQ Co-efficient 3	0	0	EQB13	EQB12	EQB11	EQB10	EQB9	EQB8
1AH	EQ Co-efficient 4	EQC7	EQC6	EQC5	EQC4	EQC3	EQC2	EQC1	EQC0
1BH	EQ Co-efficient 5	EQC15	EQC14	EQC13	EQC12	EQC11	EQC10	EQC9	EQC8
1CH	FIL1 Co-efficient 0	F1A7	F1A6	F1A5	F1A4	F1A3	F1A2	F1A1	F1A0
1DH	FIL1 Co-efficient 1	F1AS	0	F1A13	F1A12	F1A11	F1A10	F1A9	F1A8
1EH	FIL1 Co-efficient 2	F1B7	F1B6	F1B5	F1B4	F1B3	F1B2	F1B1	F1B0
1FH	FIL1 Co-efficient 3	0	0	F1B13	F1B12	F1B11	F1B10	F1B9	F1B8
20H	Power Management 4	PMAINR4	PMAINL4	PMAINR3	PMAINL3	PMAINR2	PMAINL2	PMMICR	PMMICL
21H	Mode Control 5	0	SPKMN	MICR3	MICL3	L4DIF	MIX	AIN3	LODIF
22H	Lineout Mixing Select	LOM	LOM3	RINR4	LINL4	RINR3	LINL3	RINR2	LINL2
23H	HP Mixing Select	0	HPM3	RINH4	LINH4	RINH3	LINH3	RINH2	LINH2
24H	SPK Mixing Select	0	0	RINS4	LINS4	RINS3	LINS3	RINS2	LINS2
25H	EQ Control 250Hz/100Hz	FBEQB3	FBEQB2	FBEQB1	FBEQB0	FBEQA3	FBEQA2	FBEQA1	FBEQA0
26H	EQ Control 3.5kHz/1kHz	FBEQD3	FBEQD2	FBEQD1	FBEQD0	FBEQC3	FBEQC2	FBEQC1	FBEQC0
27H	EQ Control 10kHz	0	0	0	0	FBEQE3	FBEQE2	FBEQE1	FBEQE0

Note 65. PDN pin = "L" resets the registers to their default values.

Note 66. Unused bits must contain "0" value.

■ Register Definitions

Addr	Register Name	D7	D6	D5	D4	D3	D2	D1	D0
00H	Power Management 1	PMSPR	PMVCM	PMMIN	PMSPL	PMLO	PMDAC	0	PMADL
	R/W	R/W	R/W	R/W	R/W	R/W	R/W	RD	R/W
	Default	0	0	0	0	0	0	0	0

PMADL: MIC-Amp Lch and ADC Lch Power Management

0: Power down (default)

1: Power up

When the PMADL or PMADR bit is changed from “0” to “1”, the initialization cycle ($1059/f_s=24\text{ms}$ @44.1kHz) starts. After initializing, digital data of the ADC is output.

PMDAC: DAC Power Management

0: Power down (default)

1: Power up

PMLO: Stereo Line Out Power Management

0: Power down (default)

1: Power up

PMSPL: Speaker-Amp Lch Power Management

0: Power down (default)

1: Power up

PMMIN: MIN Input Power Management

0: Power down (default)

1: Power up

PMMIN or PMAINL3 bit should be set to “1” for playback.

PMVCM: VCOM Power Management

0: Power down (default)

1: Power up

When any blocks are powered-up, the PMVCM bit must be set to “1”. PMVCM bit can be set to “0” only when all power management bits of 00H, 01H, 02H, 10H, 20H and MCKO bits are “0”.

PMSPR: Speaker-Amp Rch Power Management

0: Power down (default)

1: Power up

Each block can be powered-down respectively by writing “0” to each bit of this address. When the PDN pin is “L”, all blocks are powered-down regardless as setting of this address. In this case, register is initialized to the default value.

When all power management bits are “0” in the 00H, 01H, 02H, 10H and 20H addresses and MCKO bit is “0”, all blocks are powered-down. The register values remain unchanged.

When neither ADC nor DAC are powered-up, external clocks may not be present. When ADC or DAC is powered-up, external clocks must always be present.

Addr	Register Name	D7	D6	D5	D4	D3	D2	D1	D0
01H	Power Management 2	HPZ	HPMTN	PMHPL	PMHPR	M/S	PMHPC	MCKO	PMPLL
	R/W	R/W	R/W	R/W	R/W	R/W	R/W	R/W	R/W
	Default	0	0	0	0	0	0	0	0

PMPLL: PLL Power Management

0: EXT Mode and Power-Down (default)

1: PLL Mode and Power-up

MCKO: Master Clock Output Enable

0: Disable: MCKO pin = "L" (default)

1: Enable: Output frequency is selected by PS1-0 bits.

PMHPC: Headphone-Amp's Common Buffer Power Management

0: Power-down (default)

1: Power-up

M/S: Master / Slave Mode Select

0: Slave Mode (default)

1: Master Mode

PMHPR: Headphone-Amp Rch Power Management

0: Power-down (default)

1: Power-up

PMHPL: Headphone-Amp Lch Power Management

0: Power-down (default)

1: Power-up

HPMTN: Headphone-Amp Mute Control

0: Mute (default)

1: Normal operation

HPZ: Headphone-Amp Pull-down Control

0: Shorted to GND (default)

1: Pulled-down by 200kΩ (typ.)

This bit is enabled when Lch or Rch of Headphone-amp is powered-down.

Addr	Register Name	D7	D6	D5	D4	D3	D2	D1	D0
02H	Signal Select 1	SPPSN	MINS	DACS	DACL	0	PMMP	0	MGAIN0
	R/W	R/W	R/W	R/W	R/W	RD	R/W	RD	R/W
	Default	0	0	0	0	0	0	0	1

MGAIN1-0: MIC-Amp Gain Control (Table 22)

MGAIN1 bit is D5 bit of 03H.

PMMP: MPWR pin Power Management

0: Power down: Hi-Z (default)

1: Power up

DACL: Switch Control from DAC to Line Output

0: OFF (default)

1: ON

When PMLO bit is "1", DACL bit is enabled. When PMLO bit is "0", the LOUT/ROUT pins go to VSS1.

DACS: Switch Control from DAC to Speaker-Amp

0: OFF (default)

1: ON

When DACS bit is "1", DAC output signal is input to Speaker-Amp.

MINS: Switch Control from MIN pin to Speaker-Amp

0: OFF (default)

1: ON

When MINS bit is "1", mono signal is input to Speaker-Amp.

SPPSN: Speaker-Amp Power-Save Mode

0: Power Save Mode (default)

1: Normal Operation

When SPPSN bit is "0", Speaker-Amp is in power-save mode. In this mode, SPLP/SPRP pins go to Hi-Z and SPLN/SPRN pins output HVDD/2 voltage. When PMSPL or PMSPR bit is "1", SPPSN bit is enabled.

Addr	Register Name	D7	D6	D5	D4	D3	D2	D1	D0
03H	Signal Select 2	LOVL	LOPS	MGAIN1	SPKG1	SPKG	MINL	SPKG2	0
	R/W	R/W	R/W	R/W	R/W	R/W	R/W	R/W	RD
	Default	0	0	0	0	0	0	0	0

MINL: Switch Control from MIN pin to Stereo Line Output

0: OFF (default)

1: ON

When PMLO bit is “1”, MINL bit is enabled. When PMLO bit is “0”, the LOUT/ROUT pins go to VSS1.

SPKG2-0: Speaker-Amp Output Gain Select (Table 65)

MGAIN1: MIC-Amp Gain Control (Table 22)

LOPS: Stereo Line Output Power-Save Mode

0: Normal Operation (default)

1: Power Save Mode

LOVL: Stereo Line Output Gain Select (Table 55, Table 57)

0: 0dB/+6dB (default)

1: +2dB/+8dB

Addr	Register Name	D7	D6	D5	D4	D3	D2	D1	D0
04H	Mode Control 1	PLL3	PLL2	PLL1	PLL0	BCKO	0	DIF1	DIF0
	R/W	R/W	R/W	R/W	R/W	R/W	RD	R/W	R/W
	Default	0	0	0	0	0	0	1	0

DIF1-0: Audio Interface Format (Table 17)

Default: “10” (Left justified)

BCKO: BICK Output Frequency Select at Master Mode (Table 11)

PLL3-0: PLL Reference Clock Select (Table 5)

Default: “0000”(LRCK pin)

Addr	Register Name	D7	D6	D5	D4	D3	D2	D1	D0
05H	Mode Control 2	PS1	PS0	FS3	MSBS	BCKP	FS2	FS1	FS0
	R/W	R/W	R/W	R/W	R/W	R/W	R/W	R/W	R/W
	Default	0	0	0	0	0	0	0	0

FS3-0: Sampling Frequency Select (Table 6 and Table 7) and MCKI Frequency Select (Table 12)

FS3-0 bits select sampling frequency at PLL mode and MCKI frequency at EXT mode.

BCKP: BICK Polarity at DSP Mode (Table 18)

0: SDTO is output by the rising edge (“↑”) of BICK and SDTI is latched by the falling edge (“↓”). (Default)

1: SDTO is output by the falling edge (“↓”) of BICK and SDTI is latched by the rising edge (“↑”).

MSBS: LRCK Polarity at DSP Mode (Table 18)

0: The rising edge (“↑”) of LRCK is half clock of BICK before the channel change. (Default)

1: The rising edge (“↑”) of LRCK is one clock of BICK before the channel change.

PS1-0: MCKO Output Frequency Select (Table 10)

Default: “00” (256fs)

Addr	Register Name	D7	D6	D5	D4	D3	D2	D1	D0
06H	Timer Select	DVTM	WTM2	ZTM1	ZTM0	WTM1	WTM0	RFST1	RFST0
	R/W	R/W	R/W	R/W	R/W	R/W	R/W	R/W	R/W
	Default	0	0	0	0	0	0	0	0

RFST1-0: ALC First recovery Speed (Table 33)

Default: “00” (4 times)

WTM2-0: ALC Recovery Waiting Period (Table 30)

Default: “000” (128/fs)

ZTM1-0: ALC Limiter/Recovery Operation Zero Crossing Timeout Period (Table 29)

Default: “00” (128/fs)

DVTM: Digital Volume Transition Time Setting

0: 1061/fs (default)

1: 256/fs

This is the transition time between DVL/R7-0 bits = 00H and FFH.

Addr	Register Name	D7	D6	D5	D4	D3	D2	D1	D0
07H	ALC Mode Control 1	0	0	ALC	ZELMN	LMAT1	LMAT0	RGAIN0	LMTH0
	R/W	RD	RD	R/W	R/W	R/W	R/W	R/W	R/W
	Default	0	0	0	0	0	0	0	0

LMTH1-0: ALC Limiter Detection Level / Recovery Counter Reset Level (Table 27)

Default: "00"

LMTH1 bit is D6 bit of 0BH.

RGAIN1-0: ALC ALC Recovery GAIN Step (Table 31)

Default: "00"

RGAIN1 bit is D7 bit of 0BH.

LMAT1-0: ALC Limiter ATT Step (Table 28)

Default: "00"

ZELMN: Zero Crossing Detection Enable at ALC Limiter Operation

0: Enable (default)

1: Disable

ALC: ALC Enable

0: ALC Disable (default)

1: ALC Enable

Addr	Register Name	D7	D6	D5	D4	D3	D2	D1	D0
08H	ALC Mode Control 2	REF7	REF6	REF5	REF4	REF3	REF2	REF1	REF0
	R/W	R/W	R/W	R/W	R/W	R/W	R/W	R/W	R/W
	Default	1	1	1	0	0	0	0	1

REF7-0: Reference Value at ALC Recovery Operation. 0.375dB step, 242 Level (Table 32)

Default: "E1H" (+30.0dB)

Addr	Register Name	D7	D6	D5	D4	D3	D2	D1	D0
09H	Lch Input Volume Control	IVL7	IVL6	IVL5	IVL4	IVL3	IVL2	IVL1	IVL0
0CH	Rch Input Volume Control	IVR7	IVR6	IVR5	IVR4	IVR3	IVR2	IVR1	IVR0
	R/W	R/W	R/W	R/W	R/W	R/W	R/W	R/W	R/W
	Default	1	1	1	0	0	0	0	1

IVL7-0, IVR7-0: Input Volume; 0.375dB step, 242 Level (Table 35)

Default: "E1H" (+30.0dB)

Addr	Register Name	D7	D6	D5	D4	D3	D2	D1	D0
0AH	Lch Digital Volume Control	DVL7	DVL6	DVL5	DVL4	DVL3	DVL2	DVL1	DVL0
0DH	Rch Digital Volume Control	DVR7	DVR6	DVR5	DVR4	DVR3	DVR2	DVR1	DVR0
	R/W	R/W	R/W	R/W	R/W	R/W	R/W	R/W	R/W
	Default	0	0	0	1	1	0	0	0

DVL7-0, DVR7-0: Output Digital Volume (Table 38)

Default: "18H" (0dB)

Addr	Register Name	D7	D6	D5	D4	D3	D2	D1	D0
0BH	ALC Mode Control 3	RGAIN1	LMTH1	0	0	0	0	VBAT	0
	R/W	R/W	R/W	RD	RD	RD	RD	R/W	RD
	Default	0	0	0	0	0	0	0	0

VBAT: HP-Amp Common Voltage (Table 62)

0: 0.5 x HVDD (default)

1: 0.64 x AVDD

LMTH1: ALC Limiter Detection Level / Recovery Counter Reset Level (Table 27)

RGAIN1: ALC Recovery GAIN Step (Table 31)

Addr	Register Name	D7	D6	D5	D4	D3	D2	D1	D0
0EH	Mode Control 3	0	LOOP	SMUTE	DVOLC	0	FBEQ	DEM1	DEM0
	R/W	RD	R/W	R/W	R/W	RD	R/W	R/W	R/W
	Default	0	0	0	1	0	0	0	1

DEM1-0: De-emphasis Frequency Select (Table 36)

Default: "01" (OFF)

FBEQ: 5-Band Equalizer Enable

0: Disable (default)

1: Enable

DVOLC: Output Digital Volume Control Mode Select

0: Independent

1: Dependent (default)

When DVOLC bit = "1", DVL7-0 bits control both Lch and Rch volume level, while register values of DVL7-0 bits are not written to DVR7-0 bits. When DVOLC bit = "0", DVL7-0 bits control Lch level and DVR7-0 bits control Rch level, respectively.

SMUTE: Soft Mute Control

0: Normal Operation (default)

1: DAC outputs soft-muted

LOOP: Digital Loopback Mode

0: SDTI → DAC (default)

1: SDTO → DAC

Addr	Register Name	D7	D6	D5	D4	D3	D2	D1	D0
0FH	Mode Control 4	HPG3	HPG2	HPG1	HPG0	IVOLC	HPM	MINH	DACH
	R/W	R/W	R/W	R/W	R/W	R/W	R/W	R/W	R/W
	Default	1	0	1	1	1	0	0	0

DACH: Switch Control from DAC to Headphone-Amp

- 0: OFF (default)
- 1: ON

MINH: Switch Control from MIN pin to Headphone-Amp

- 0: OFF (default)
- 1: ON

HPM: Headphone-Amp Mono Output Select

- 0: Stereo (default)
- 1: Mono

When the HPM bit = "1", DAC output signal is output to Lch and Rch of the Headphone-Amp as (L+R)/2.

IVOLC: Input Digital Volume Control Mode Select

- 0: Independent
- 1: Dependent (default)

When IVOLC bit = "1", IVL7-0 bits control both Lch and Rch volume level, while register values of IVL7-0 bits are not written to IVR7-0 bits. When IVOLC bit = "0", IVL7-0 bits control Lch level and IVR7-0 bits control Rch level, respectively.

HPG3-0: Headphone-Amp Volume Control

Default: 0dB (Table 58)

Addr	Register Name	D7	D6	D5	D4	D3	D2	D1	D0
10H	Power Management 3	INR1	INL1	0	MDIF2	MDIF1	INR0	INL0	PMADR
	R/W	R/W	R/W	RD	R/W	R/W	R/W	R/W	R/W
	Default	0	0	0	0	0	0	0	0

PMADR: MIC-Amp Lch and ADC Rch Power Management

- 0: Power-down (default)
- 1: Power-up

INL1-0: ADC Lch Input Source Select (Table 20)

Default: 00 (LIN1 pin)

INR1-0: ADC Rch Input Source Select (Table 20)

Default: 00 (RIN1 pin)

MDIF1: Single-ended / Full-differential Input Select 1

- 0: Single-ended input (LIN1/RIN1 pins: Default)
 - 1: Full-differential input (IN1+/IN1- pins)
- MDIF1 bit selects the input type of pins D7 and F5.

MDIF2: Single-ended / Full-differential Input Select 2

- 0: Single-ended input (LIN2/RIN2 pins: Default)
 - 1: Full-differential input (IN2+/IN2- pins)
- MDIF2 bit selects the input type of pins C5 and B6.

Addr	Register Name	D7	D6	D5	D4	D3	D2	D1	D0
11H	Digital Filter Select	GN1	GN0	0	FIL1	EQ	FIL3	0	0
	R/W	R/W	R/W	RD	R/W	R/W	R/W	RD	RD
	Default	0	0	0	0	0	0	0	0

GN1-0: : Gain Select at GAIN block (Table 25)
 Default: "00" (0dB)

FIL3: FIL3 (Stereo Separation Emphasis Filter) Coefficient Setting Enable

0: Disable (default)

1: Enable

When FIL3 bit is "1", the settings of F3A13-0 and F3B13-0 bits are enabled. When FIL3 bit is "0", FIL3 block is OFF (MUTE).

EQ: EQ (Gain Compensation Filter) Coefficient Setting Enable

0: Disable (default)

1: Enable

When EQ bit is "1", the settings of EQA15-0, EQB13-0 and EQC15-0 bits are enabled. When EQ bit is "0", EQ block is through (0dB).

FIL1: FIL1 (Wind-noise Reduction Filter) Coefficient Setting Enable

0: Disable (default)

1: Enable

When FIL1 bit is "1", the settings of F1A13-0 and F1B13-0 bits are enabled. When FIL1 bit is "0", FIL1 block is through (0dB).

Addr	Register Name	D7	D6	D5	D4	D3	D2	D1	D0
12H	FIL3 Co-efficient 0	F3A7	F3A6	F3A5	F3A4	F3A3	F3A2	F3A1	F3A0
13H	FIL3 Co-efficient 1	F3AS	0	F3A13	F3A12	F3A11	F3A10	F3A9	F3A8
14H	FIL3 Co-efficient 2	F3B7	F3B6	F3B5	F3B4	F3B3	F3B2	F3B1	F3B0
15H	FIL3 Co-efficient 3	0	0	F3B13	F3B12	F3B11	F3B10	F3B9	F3B8
16H	EQ Co-efficient 0	EQA7	EQA6	EQA5	EQA4	EQA3	EQA2	EQA1	EQA0
17H	EQ Co-efficient 1	EQA15	EQA14	EQA13	EQA12	EQA11	EQA10	EQA9	EQA8
18H	EQ Co-efficient 2	EQB7	EQB6	EQB5	EQB4	EQB3	EQB2	EQB1	EQB0
19H	EQ Co-efficient 3	0	0	EQB13	EQB12	EQB11	EQB10	EQB9	EQB8
1AH	EQ Co-efficient 4	EQC7	EQC6	EQC5	EQC4	EQC3	EQC2	EQC1	EQC0
1BH	EQ Co-efficient 5	EQC15	EQC14	EQC13	EQC12	EQC11	EQC10	EQC9	EQC8
1CH	FIL1 Co-efficient 0	F1A7	F1A6	F1A5	F1A4	F1A3	F1A2	F1A1	F1A0
1DH	FIL1 Co-efficient 1	F1AS	0	F1A13	F1A12	F1A11	F1A10	F1A9	F1A8
1EH	FIL1 Co-efficient 2	F1B7	F1B6	F1B5	F1B4	F1B3	F1B2	F1B1	F1B0
1FH	FIL1 Co-efficient 3	0	0	F1B13	F1B12	F1B11	F1B10	F1B9	F1B8
R/W		R/W	R/W	R/W	R/W	R/W	R/W	R/W	R/W
Default		0	0	0	0	0	0	0	0

F3A13-0, F3B13-0: FIL3 (Stereo Separation Emphasis Filter) Coefficient (14bit x 2)
 Default: "0000H"

F3AS: FIL3 (Stereo Separation Emphasis Filter) Select
 0: HPF (default)
 1: LPF

EQA15-0, EQB13-0, EQC15-C0: EQ (Gain Compensation Filter) Coefficient (14bit x 2 + 16bit x 1)
 Default: "0000H"

F1A13-0, F1B13-B0: FIL1 (Wind-noise Reduction Filter) Coefficient (14bit x 2)
 Default: "0000H"

F1AS: FIL1 (Wind-noise Reduction Filter) Select
 0: HPF (default)
 1: LPF

Addr	Register Name	D7	D6	D5	D4	D3	D2	D1	D0
20H	Power Management 4	PMAINR4	PMAINL4	PMAINR3	PMAINL3	PMAINR2	PMAINL2	PMMICR	PMMICL
	R/W	R/W	R/W	R/W	R/W	R/W	R/W	R/W	R/W
	Default	0	0	0	0	0	0	0	0

PMMICL: MIC-Amp Lch Power Management

0: Power down (default)

1: Power up

PMMICR: MIC-Amp Rch Power Management

0: Power down (default)

1: Power up

PMAINL2: LIN2 Mixing Circuit Power Management

0: Power down (default)

1: Power up

PMAINR2: RIN2 Mixing Circuit Power Management

0: Power down (default)

1: Power up

PMAINL3: LIN3 Mixing Circuit Power Management

0: Power down (default)

1: Power up

PMMIN or PMAINL3 bit should be set to "1" for playback.

PMAINR3: RIN3 Mixing Circuit Power Management

0: Power down (default)

1: Power up

PMAINL4: LIN4 Mixing Circuit Power Management

0: Power down (default)

1: Power up

PMAINR4: RIN4 Mixing Circuit Power Management

0: Power down (default)

1: Power up

Addr	Register Name	D7	D6	D5	D4	D3	D2	D1	D0
21H	Mode Control 5	0	SPKMN	MICR3	MICL3	L4DIF	MIX	AIN3	LODIF
	R/W	RD	R/W	R/W	R/W	R/W	R/W	R/W	R/W
	Default	0	0	0	0	0	0	0	0

LODIF: Lineout Select

- 0: Single-ended Stereo Line Output (LOUT/ROUT pins) (default)
- 1: Full-differential Mono Line Output (LOP/LON pins)

AIN3: Analog Mixing Select

- 0: Mono Input (MIN pin) (default)
- 1: Stereo Input (LIN3/RIN3 pins): PLL is not available.

MIX: Mono Recording

- 0: Stereo (default)
- 1: Mono: (L+R)/2

L4DIF: Line Input Type Select

- 0: Stereo Single-ended Input: LIN4/RIN4 pins (default)
- 1: Mono Full-differential Input: IN4+/- pins

MICL3: Switch Control from MIC-Amp Lch to Analog Output

- 0: LIN3 input signal is selected. (default)
- 1: MIC-Amp Lch output signal is selected.

MICR3: Switch Control from MIC-Amp Rch to Analog Output

- 0: RIN3 input signal is selected. (default)
- 1: MIC-Amp Rch output signal is selected.

SPKMN: Speaker-Amp Output Mode Select (Table 68)

- 0: Mono SPK Mode or High Power Mono SPK Mode (default)
- 1: Stereo SPK Mode

Addr	Register Name	D7	D6	D5	D4	D3	D2	D1	D0
22H	Lineout Mixing Select	LOM	LOM3	RINR4	LINL4	RINR3	LINL3	RINR2	LINL2
	R/W	R/W	R/W	R/W	R/W	R/W	R/W	R/W	R/W
	Default	0	0	0	0	0	0	0	0

LINL2: Switch Control from LIN2 pin to Stereo Line Output (without MIC-Amp)

0: OFF (default)

1: ON

RINR2: Switch Control from RIN2 pin to Stereo Line Output (without MIC-Amp)

0: OFF (default)

1: ON

LINL3: Switch Control from LIN3 pin (or MIC-Amp Lch) to Stereo Line Output

0: OFF (default)

1: ON

RINR3: Switch Control from RIN3 pin (or MIC-Amp Rch) to Stereo Line Output

0: OFF (default)

1: ON

LINL4: Switch Control from LIN4 pin to Stereo Line Output (without MIC-Amp)

0: OFF (default)

1: ON

RINR4: Switch Control from RIN4 pin to Stereo Line Output (without MIC-Amp)

0: OFF (default)

1: ON

LOM3: Mono Mixing from MIC-Amp (or LIN3/RIN3) to Stereo Line Output

0: Stereo Mixing (default)

1: Mono Mixing

LOM: Mono Mixing from DAC to Stereo Line Output

0: Stereo Mixing (default)

1: Mono Mixing

Addr	Register Name	D7	D6	D5	D4	D3	D2	D1	D0
23H	HP Mixing Select	0	HPM3	RINH4	LINH4	RINH3	LINH3	RINH2	LINH2
	R/W	RD	R/W	R/W	R/W	R/W	R/W	R/W	R/W
	Default	0	0	0	0	0	0	0	0

LINH2: Switch Control from LIN2 pin to Headphone Output (without MIC-Amp)

0: OFF (default)

1: ON

RINH2: Switch Control from RIN2 pin to Headphone Output (without MIC-Amp)

0: OFF (default)

1: ON

LINH3: Switch Control from LIN3 pin (or MIC-Amp Lch) to Headphone Output

0: OFF (default)

1: ON

RINH3: Switch Control from RIN3 pin (or MIC-Amp Rch) to Headphone Output

0: OFF (default)

1: ON

LINH4: Switch Control from LIN4 pin to Headphone Output (without MIC-Amp)

0: OFF (default)

1: ON

RINH4: Switch Control from RIN4 pin to Headphone Output (without MIC-Amp)

0: OFF (default)

1: ON

HPM3: Mono Mixing from MIC-Amp (or LIN3/RIN3) to Headphone Output

0: Stereo Mixing (default)

1: Mono Mixing

Addr	Register Name	D7	D6	D5	D4	D3	D2	D1	D0
24H	SPK Mixing Select	0	0	RINS4	LINS4	RINS3	LINS3	RINS2	LINS2
	R/W	RD	RD	R/W	R/W	R/W	R/W	R/W	R/W
	Default	0	0	0	0	0	0	0	0

LINS2: Switch Control from LIN2 pin to Speaker Output

0: OFF (default)

1: ON

RINS2: Switch Control from RIN2 pin to Speaker Output

0: OFF (default)

1: ON

LINS3: Switch Control from LIN3 pin to Speaker Output

0: OFF (default)

1: ON

RINS3: Switch Control from RIN3 pin to Speaker Output

0: OFF (default)

1: ON

LINS4: Switch Control from LIN4 pin to Speaker Output

0: OFF (default)

1: ON

RINS4: Switch Control from RIN4 pin to Speaker Output

0: OFF (default)

1: ON

Addr	Register Name	D7	D6	D5	D4	D3	D2	D1	D0
25H	EQ Control of 250Hz/100Hz	FBEQB3	FBEQB2	FBEQB1	FBEQB0	FBEQA3	FBEQA2	FBEQA1	FBEQA0
26H	EQ Control of 3.5kHz/1kHz	FBEQD3	FBEQD2	FBEQD1	FBEQD0	FBEQC3	FBEQC2	FBEQC1	FBEQC0
	R/W	R/W	R/W	R/W	R/W	R/W	R/W	R/W	R/W
	Default	1	0	0	0	1	0	0	0

Addr	Register Name	D7	D6	D5	D4	D3	D2	D1	D0
27H	EQ Control of 10kHz	0	0	0	0	FBEQE3	FBEQE2	FBEQE1	FBEQE0
	R/W	RD	RD	RD	RD	R/W	R/W	R/W	R/W
	Default	0	0	0	0	1	0	0	0

Select boost amount of 5-Band Equalizer (Table 37). When FBEQ bit is set to “1”, the 5-Band Equalize function is enabled.

FBEQA3-0: Select the boost level of 100Hz (Default: 0dB)

FBEQB3-0: Select the boost level of 250Hz (Default: 0dB)

FBEQC3-0: Select the boost level of 1kHz (Default: 0dB)

FBEQD3-0: Select the boost level of 3.5kHz (Default: 0dB)

FBEQE3-0: Select the boost level of 10kHz (Default: 0dB)

SYSTEM DESIGN

Figure 69 and Figure 70 show the system connection diagram of the AK4648. The evaluation board [AKD4648] demonstrates the optimum layout, power supply arrangements and measurement results.

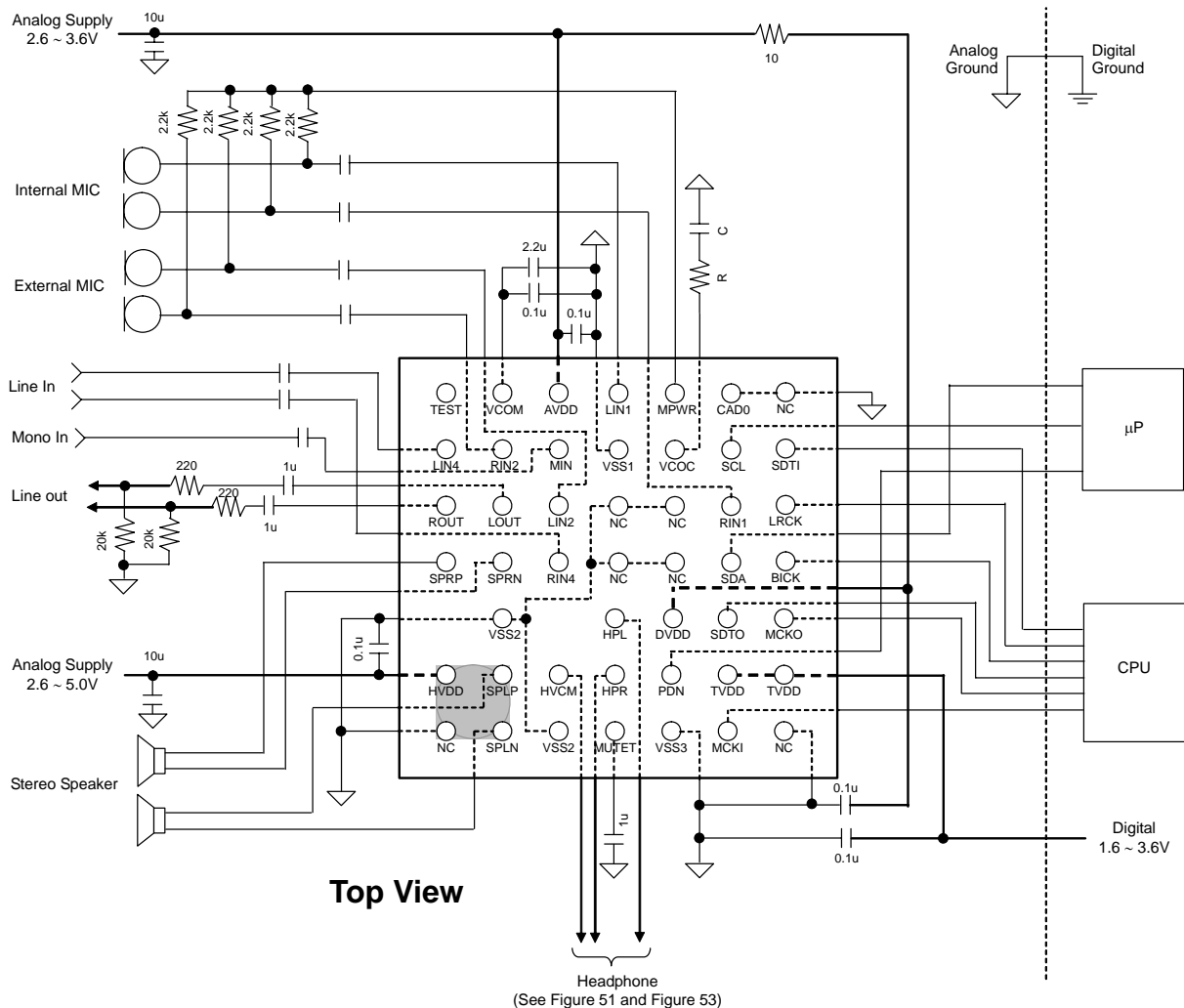

Notes:

- VSS1, VSS2, and VSS3 of the AK4648 should be distributed separately from the ground of external controllers.
- All digital input pins should not be left floating.
- When the AK4648 is EXT mode (PMPLL bit = "0"), a resistor and capacitor of VCOG/RIN3 pin is not needed.
- When the AK4648 is PLL mode (PMPLL bit = "1"), a resistor and capacitor of VCOG/RIN3 pin is should be connected as shown in Table 5.
- When the AK4648 is used in master mode, LRCK and BICK pins are floating before M/S bit is changed to "1". Therefore, 100kΩ around pull-up resistor should be connected to LRCK and BICK pins of the AK4648.
- When DVDD is supplied from AVDD via 10Ω resistor, a capacitor should be 0.1μF or less.

Figure 69. Typical Connection Diagram (AIN3 bit = "0", CAD0 = "0", MIC Input, Stereo SPK Mode)

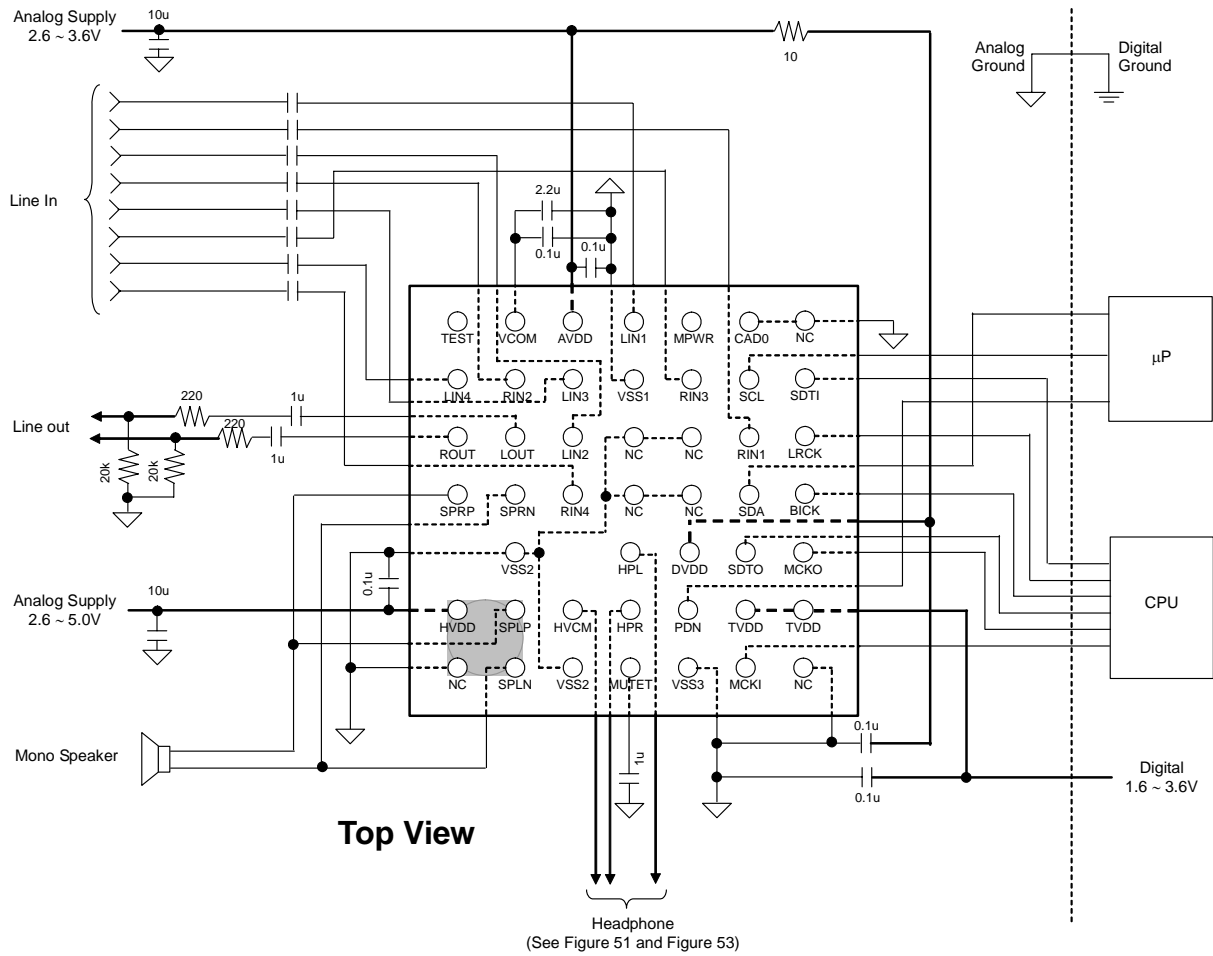

Notes:

- VSS1, VSS2, and VSS3 of the AK4648 should be distributed separately from the ground of external controllers.
- All digital input pins should not be left floating.
- When AIN3 bit = "1", PLL is not available.
- When the AK4648 is used in master mode, LRCK and BICK pins are floating before M/S bit is changed to "1". Therefore, 100kΩ around pull-up resistor should be connected to LRCK and BICK pins of the AK4648.
- When DVDD is supplied from AVDD via 10Ω resistor, a capacitor should be 0.1µF or less.

Figure 70. Typical Connection Diagram
 (AIN3 bit = "1": PLL is not available, CAD0 = "0", Line Input, High Power Mono SPK Mode)

1. Grounding and Power Supply Decoupling

The AK4648 requires careful attention to power supply and grounding arrangements. AVDD, DVDD, TVDD and HVDD are usually supplied from the system's analog supply. If AVDD, DVDD, TVDD and HVDD are supplied separately, the power-up sequence is not critical.

PDN pin should be held to "L" upon power-up. PDN pin should be set to "H" after all power supplies are powered-up. In case that the pop noise should be avoided at speaker output, line output, and headphone output, the AK4648 should be operated by the following recommended power-up/down sequence.

- 1) Power-up
 - PDN pin should be held to "L" upon power-up. The AK4648 should be reset by bringing PDN pin "L" for 150ns or more.
 - In case that the power supplies are separated in two or more groups, the power supply including TVDD should be powered ON at first. Regarding the relationship between DVDD and HVDD, the power supply including DVDD should be powered ON prior to the power supply including HVDD.
- 2) Power-down
 - Each power supplies should be powered OFF after PDN pin is set to "L".
 - In case that the power supplies are separated in two or more groups, the power supply including TVDD should be powered OFF at last. Regarding the relationship between DVDD and HVDD, the power supply including HVDD should be powered OFF prior to the power supply including DVDD.

VSS1, VSS2, and VSS3 of the AK4648 should be connected to the analog ground plane. System analog ground and digital ground should be connected together near to where the supplies are brought onto the printed circuit board. Decoupling capacitors should be as near to the AK4648 as possible, with the small value ceramic capacitor being the nearest.

2. Voltage Reference

VCOM is a signal ground of this chip. A 2.2 μ F electrolytic capacitor in parallel with a 0.1 μ F ceramic capacitor attached to the VCOM pin eliminates the effects of high frequency noise. No load current may be drawn from the VCOM pin. All signals, especially clocks, should be kept away from the VCOM pin in order to avoid unwanted coupling into the AK4648.

3. Analog Inputs

The Mic, Line and MIN inputs are single-ended. The input signal range scales with nominally at 0.06 x AVDD Vpp(typ.) @MGAIN1-0 bits = "01", 0.03 x AVDD Vpp(typ.) @MGAIN1-0 bits = "10", 0.015 x AVDD Vpp(typ.) @MGAIN1-0 bits = "11" or 0.6 x AVDD Vpp(typ.) @MGAIN1-0 bits = "00" for the Mic/Line input and 0.6 x AVDD Vpp (typ.) for the MIN input, centered around the internal common voltage (0.45 x AVDD). Usually the input signal is AC coupled using a capacitor. The cut-off frequency is $f_c = 1 / (2\pi RC)$. The AK4648 can accept input voltages from VSS1 to AVDD.

4. Analog Outputs

The input data format for the DAC is 2's complement. The output voltage is a positive full scale for 7FFFH(@16bit) and a negative full scale for 8000H(@16bit). The ideal output is VCOM voltage for 0000H(@16bit). Stereo Line Output is centered at 0.45 x AVDD. Headphone-Amp and Speaker-Amp outputs are centered at HVDD/2.

CONTROL SEQUENCE

■ Clock Set up

When ADC or DAC is powered-up, the clocks must be supplied.

1. PLL Master Mode.

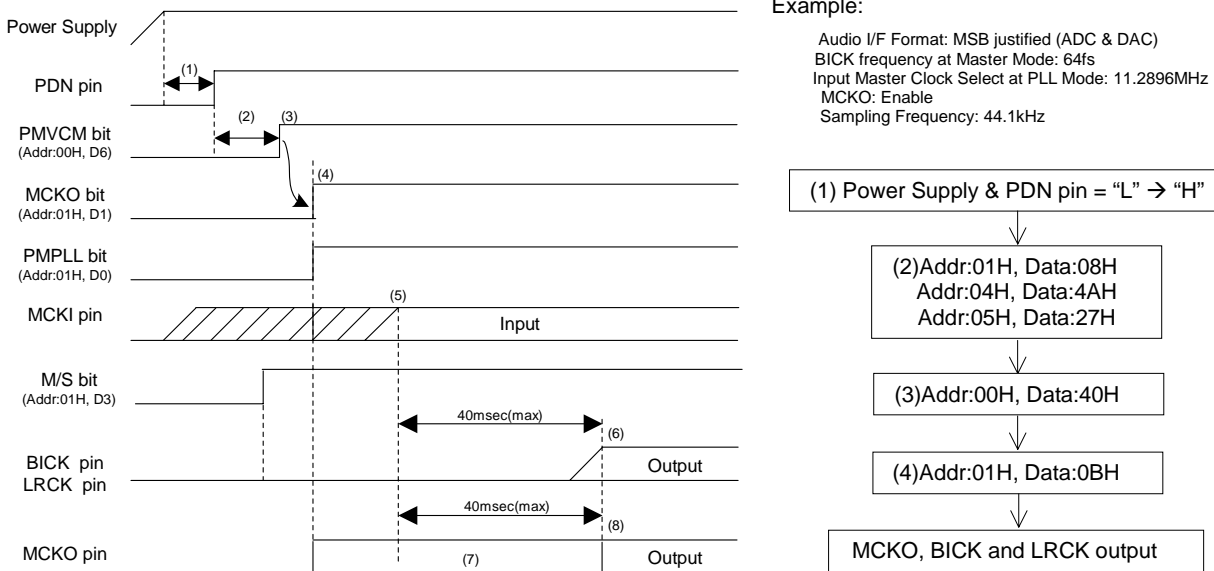

Figure 71. Clock Set Up Sequence (1)

<Example>

- (1) After Power Up, PDN pin = "L" → "H". "L" time of 150ns or more is needed to reset the AK4648.
The AK4648 should be operated as the recommended power-up/down sequence shown in "System Design (Grounding and Power Supply Decoupling)" to avoid the pop noise at the speaker output, lineout output, and headphone output.
- (2) DIF1-0, PLL3-0, FS3-0, BCKO and M/S bits should be set during this period.
- (3) Power Up VCOM: PMVCM bit = "0" → "1"
VCOM should first be powered-up before the other block operates.
- (4) In case of using MCKO output: MCKO bit = "1"
In case of not using MCKO output: MCKO bit = "0"
- (5) PLL lock time is 40ms(max.) after PMPLL bit changes from "0" to "1" and MCKI is supplied from an external source.
- (6) The AK4648 starts to output the LRCK and BICK clocks after the PLL becomes stable. Then normal operation starts.
- (7) The invalid frequency is output from MCKO pin during this period if MCKO bit = "1".
- (8) The normal clock is output from MCKO pin after the PLL is locked if MCKO bit = "1".

2. PLL Slave Mode (LRCK or BICK pin)

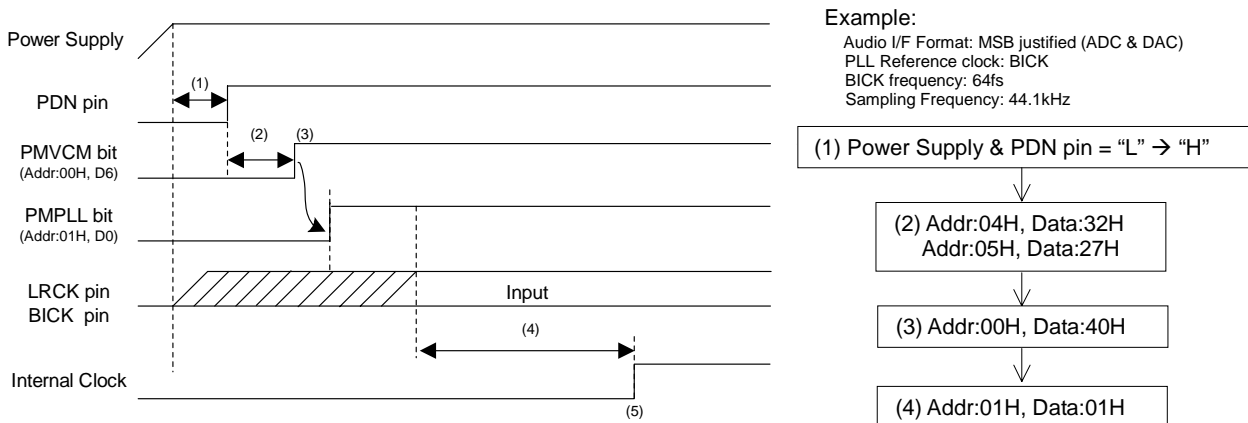

Figure 72. Clock Set Up Sequence (2)

<Example>

- (1) After Power Up, PDN pin = "L" → "H". "L" time of 150ns or more is needed to reset the AK4648. The AK4648 should be operated as the recommended power-up/down sequence shown in "System Design (Grounding and Power Supply Decoupling)" to avoid the pop noise at the speaker output, lineout output, and headphone output.
- (2) DIF1-0, FS3-0 and PLL3-0 bits should be set during this period.
- (3) Power Up VCOM: PMVCM bit = "0" → "1"
 VCOM should first be powered up before the other block operates.
- (4) PLL starts after the PMPLL bit changes from "0" to "1" and PLL reference clock (LRCK or BICK pin) is supplied. PLL lock time is 160ms(max.) when LRCK is a PLL reference clock. And PLL lock time is 2ms(max.) when BICK is a PLL reference clock.
- (5) Normal operation starts after that the PLL is locked.

3. PLL Slave Mode (MCKI pin)

Example:

Audio I/F Format: MSB justified (ADC & DAC)
 BICK frequency at Master Mode: 64fs
 Input Master Clock Select at PLL Mode: 11.2896MHz
 MCKO: Enable
 Sampling Frequency: 44.1kHz

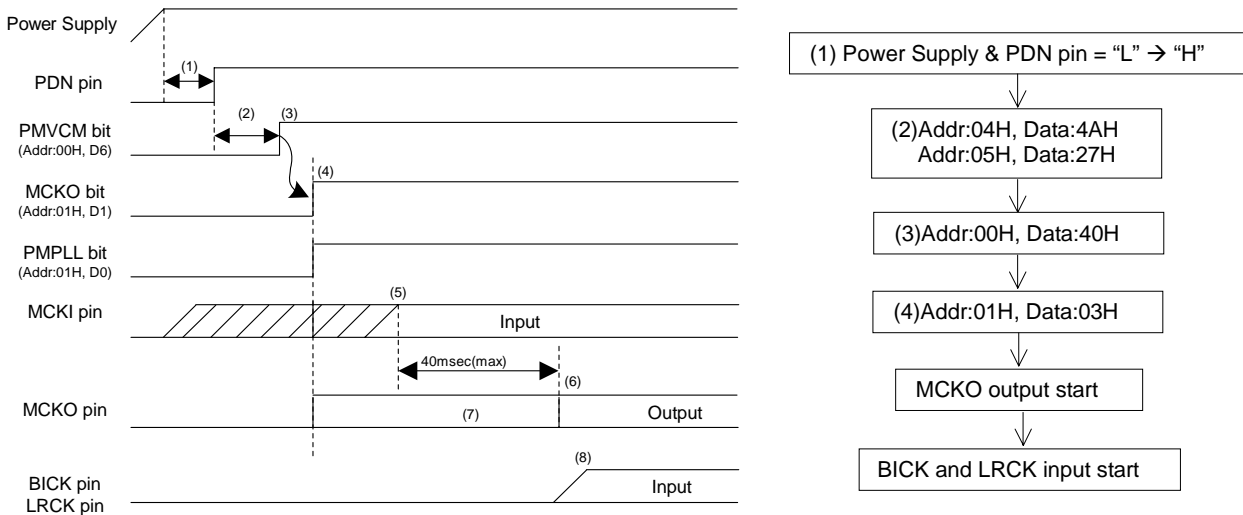

Figure 73. Clock Set Up Sequence (3)

<Example>

- (1) After Power Up, PDN pin = "L" → "H". "L" time of 150ns or more is needed to reset the AK4648. The AK4648 should be operated as the recommended power-up/down sequence shown in "System Design (Grounding and Power Supply Decoupling)" to avoid the pop noise at the speaker output, lineout output, and headphone output.
- (2) DIF1-0, PLL3-0 and FS3-0 bits should be set during this period.
- (3) Power Up VCOM: PMVCM bit = "0" → "1"
VCOM should first be powered up before the other block operates.
- (4) Enable MCKO output: MCKO bit = "1"
- (5) PLL starts after that the PMPLL bit changes from "0" to "1" and PLL reference clock (MCKI pin) is supplied. PLL lock time is 40ms(max.).
- (6) The normal clock is output from MCKO during this period.
- (7) The invalid frequency is output from MCKO after PLL is locked.
- (8) BICK and LRCK clocks should be synchronized with MCKO clock.

4. EXT Slave Mode

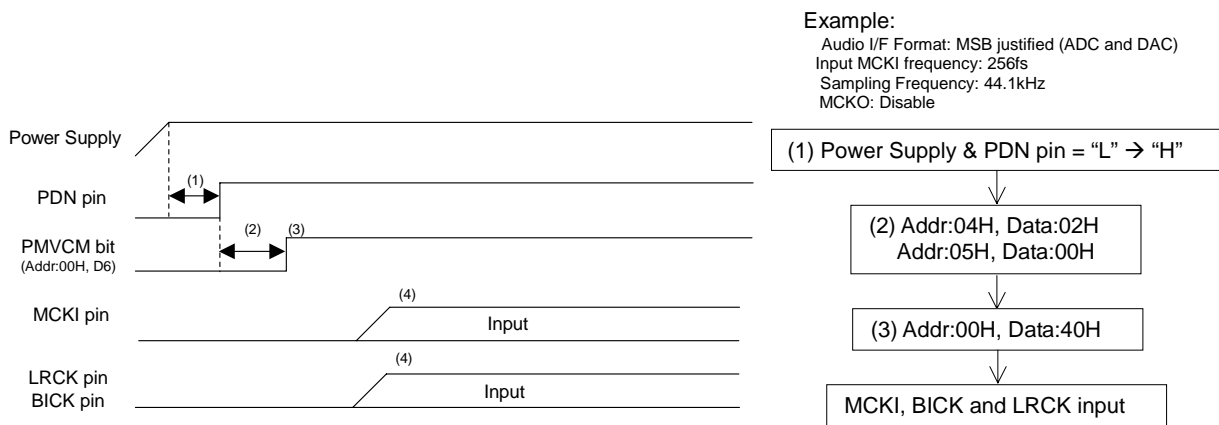

Figure 74. Clock Set Up Sequence (4)

<Example>

- (1) After Power Up, PDN pin = "L" → "H". "L" time of 150ns or more is needed to reset the AK4648.
 The AK4648 should be operated as the recommended power-up/down sequence shown in "System Design (Grounding and Power Supply Decoupling)" to avoid the pop noise at the speaker output, lineout output, and headphone output.
- (2) DIF1-0 and FS1-0 bits should be set during this period.
- (3) Power Up VCOM: PMVCM bit = "0" → "1"
 VCOM should first be powered up before the other block operates.
- (4) Normal operation starts after the MCKI, LRCK and BICK are supplied.

5. EXT Master Mode

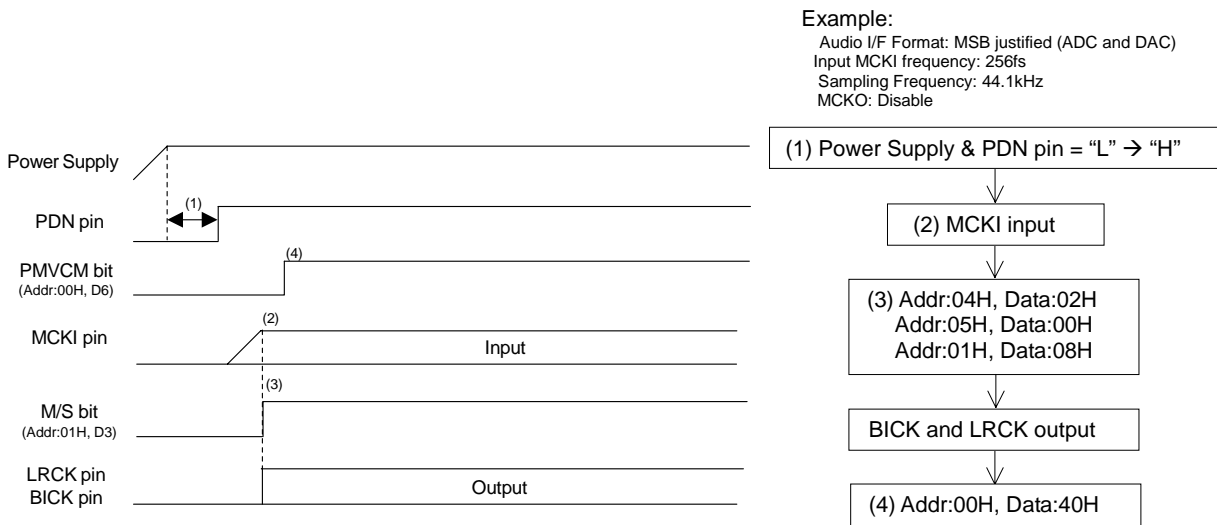

Figure 75. Clock Set Up Sequence (5)

<Example>

- (1) After Power Up, PDN pin = "L" → "H". "L" time of 150ns or more is needed to reset the AK4648.
 The AK4648 should be operated as the recommended power-up/down sequence shown in "System Design (Grounding and Power Supply Decoupling)" to avoid the pop noise at the speaker output, lineout output, and headphone output.
- (2) MCKI should be input.
- (3) After DIF1-0 and FS1-0 bits are set, M/S bit should be set to "1". Then LRCK and BICK are output.
- (4) Power Up VCOM: PMVCM bit = "0" → "1"
 VCOM should first be powered up before the other block operates.

■ MIC Input Recording (Stereo)

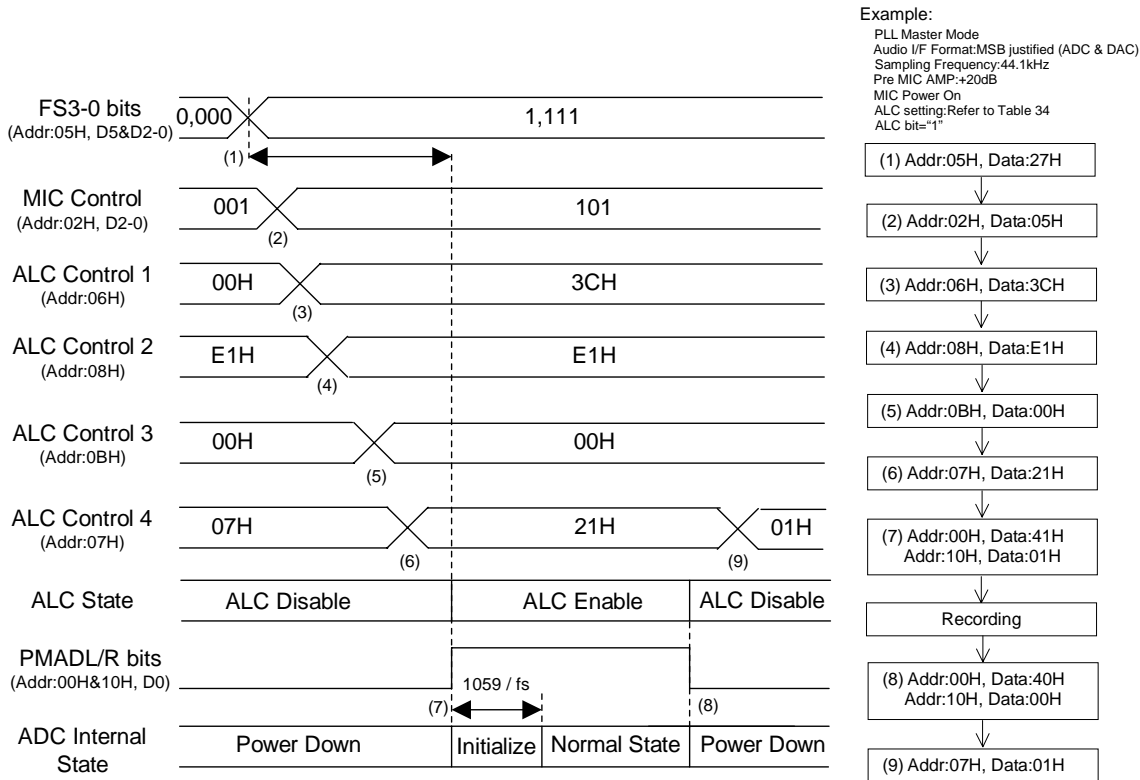

Figure 76. MIC Input Recording Sequence

<Example>

This sequence is an example of ALC setting at $f_s=44.1\text{kHz}$. If the parameter of the ALC is changed, please refer to "Figure 35."

At first, clocks should be supplied according to "Clock Set Up" sequence.

- (1) Set up a sampling frequency (FS3-0 bit). When the AK4648 is PLL mode, MIC and ADC should be powered-up in consideration of PLL lock time after a sampling frequency is changed.
- (2) Set up MIC input (Addr: 02H)
- (3) Set up Timer Select for ALC (Addr: 06H)
- (4) Set up REF value for ALC (Addr: 08H)
- (5) Set up LMTH1 and RGAIN1 bits (Addr: 0BH)
- (6) Set up LMTH0, RGAIN0, LMAT1-0 and ALC bits (Addr: 07H)
- (7) Power Up MIC and ADC: PMADL = PMADR bits = "0" → "1"

The initialization cycle time of ADC is $1059/f_s=24\text{ms}@f_s=44.1\text{kHz}$.

After the ALC bit is set to "1" and MIC&ADC block is powered-up, the ALC operation starts from IVOL default value (+30dB).

The time of offset voltage going to "0" after the ADC initialization cycle depends on both the time of analog input pin going to the common voltage and the time constant of the offset cancel digital HPF. This time can be shorter by using the following sequence:

At first, PMVCM and PMMP bits should set to "1". Then, the ADC should be powered-up. The wait time to power-up the ADC should be longer than 4 times of the time constant that is determined by the AC coupling capacitor at analog input pin and the internal input resistance 60k(typ.).

- (8) Power Down MIC and ADC: PMADL = PMADR bits = "1" → "0"
 When the registers for the ALC operation are not changed, ALC bit may be keeping "1". The ALC operation is disabled because the MIC&ADC block is powered-down. If the registers for the ALC operation are also changed when the sampling frequency is changed, it should be done after the AK4648 goes to the manual mode (ALC bit = "0") or MIC&ADC block is powered-down (PMADL=PMADR bits = "0"). IVOL gain is not reset when PMADL=PMADR bits = "0", and then IVOL operation starts from the setting value when PMADL or PMADR bit is changed to "1". ALC Disable: ALC bit = "1" → "0"
- (9) ALC Disable: ALC bit = "1" → "0"

Speaker-amp Output

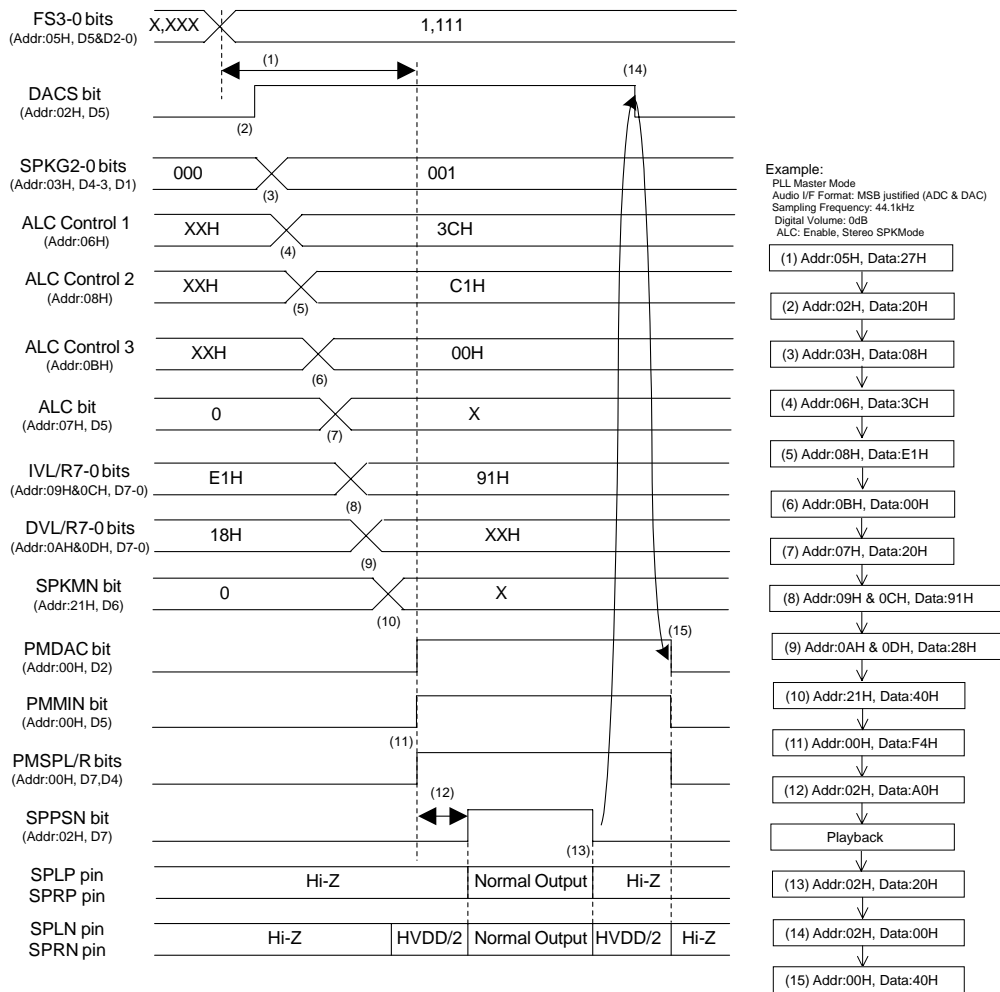

Figure 77. Speaker-Amp Output Sequence

<Example>

At first, clocks should be supplied according to “Clock Set Up” sequence.

- (1) Set up a sampling frequency (FS3-0 bits). When the AK4648 is PLL mode, DAC and Speaker-Amp should be powered-up in consideration of PLL lock time after a sampling frequency is changed.
- (2) Set up the path of “DAC → SPK-Amp”: DACS bit = “0” → “1”
- (3) SPK-Amp gain setting: SPKG2-0 bits = “000” → “001”
- (4) Set up Timer Select for ALC (Addr: 06H)
- (5) Set up REF value for ALC (Addr: 08H)
- (6) Set up LMTH1 and RGAIN1 bits (Addr: 0BH)
- (7) Set up LMTH0, RGAIN0, LMAT1-0 and ALC bits (Addr: 07H)
 When PMADL or PMADR bit is “1”, ALC for DAC path is disabled.
- (8) Set up the input digital volume (Addr: 09H and 0CH)
 When PMADL = PMADR bits = “0”, IVL7-0 and IVR7-0 bits should be set to “91H”(0dB).
- (9) Set up the output digital volume (Addr: 0AH and 0DH).
 When DVOLC bit is “1” (default), DVL7-0 bits (Addr=0AH) set the volume of both channels. After DAC is powered-up, the digital volume changes from default value (0dB) to the register setting value by the soft transition.
- (10) Set up Speaker Output Mode: SPKMN bit: “0” → “1” (Stereo SPK Mode)
 SPKMN bit should be set to “0” in Mono SPK Mode or High Power Mono SPK Mode.

(11) Power Up of DAC, MIN-Amp and Speaker-Amp:

- a. Mono SPK Mode (When Lch Speaker-Amp, SPLP/SPLN pins are used.): PMDAC = PMMIN = PMSPL bits = "0" → "1"
- b. Stereo SPK Mode or High Power Mono SPK Mode: PMDAC = PMMIN = PMSPL = PMSPR bits = "0" → "1"

The DAC enters an initialization cycle when the PMDAC bit is changed from "0" to "1" at PMADL and PMADR bits are "0". The initialization cycle time is $1059/f_s=24\text{ms}@f_s=44.1\text{kHz}$. During the initialization cycle, the DAC input digital data of both channels are internally forced to a 2's complement, "0". The DAC output reflects the digital input data after the initialization cycle is complete. When PMADL or PMADR bit is "1", the DAC does not require an initialization cycle. When ALC bit is "1", ALC is disable (ALC gain is set by IVL/R7-0 bits) during an initialization cycle ($1059/f_s=24\text{ms}@f_s=44.1\text{kHz}$). After the initialization cycle, ALC operation starts from the gain set by IVL/R7-0 bits.

(12) Exit the power-save-mode of Speaker-Amp: SPPSN bit = "0" → "1"

The powered-down channel is Hi-Z in Mono SPK Mode.

(13) Enter the power-save-mode of Speaker-Amp : SPPSN bit = "1" → "0"

(14) Disable the path of "DAC → SPK-Amp": DACS bit = "1" → "0"

(15) Power Down DAC, MIN-Amp and Speaker-Amp: PMDAC = PMMIN = PMSPL = PMSPR bits = "1" → "0"

■ Mono signal output from Speaker-Amp

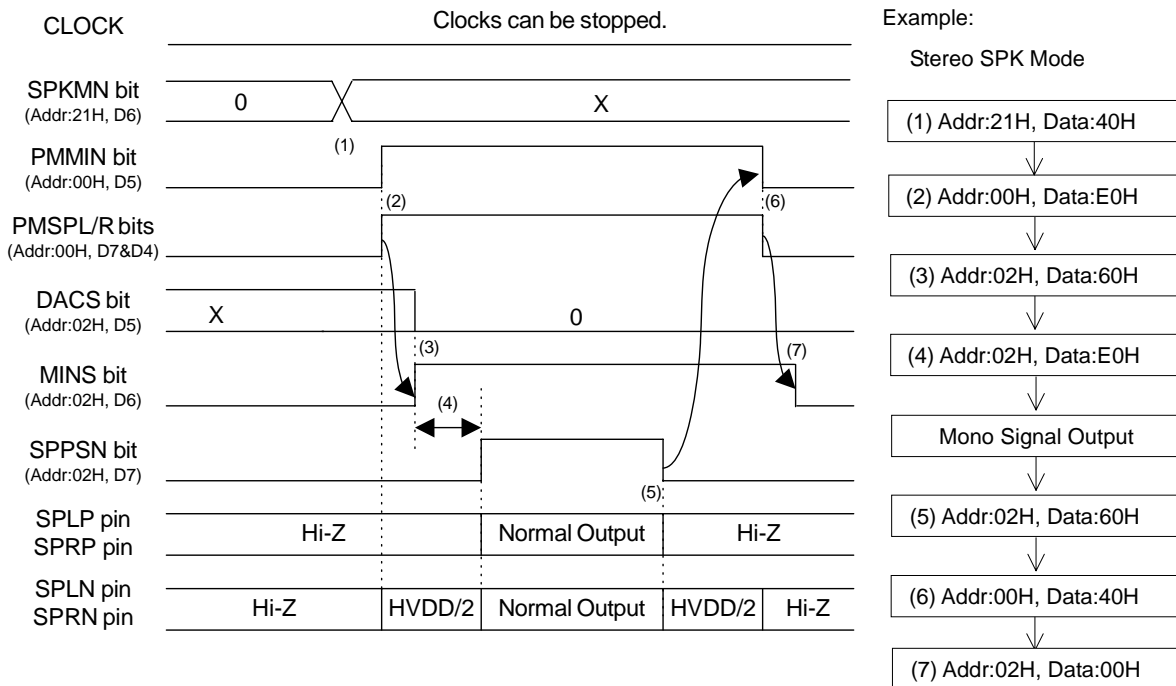

Figure 78. “MIN-Amp → Speaker-Amp” Output Sequence

<Example>

The clocks can be stopped when only MIN-Amp and Speaker-Amp are operating.

- (1) Set up speaker output mode
 - a. Mono SPK Mode & High Power Mono SPK Mode: SPKMN bit = “0”
 - b. Stereo SPK Mode: SPKMN bit = “1”
- (2) Power Up MIN-Amp and Speaker-Amp:
 - a. Mono SPK Mode (When Lch Speaker-Amp, SPLP/SPLN pins are used.): PMMIN = PMSPL bits = “0” → “1”
 - b. Stereo SPK Mode or High Power Mono SPK Mode: PMMIN = PMSPL = PMSPR bits = “0” → “1”
- (3) Disable the path of “DAC → SPK-Amp”: DACS bit = “0”
Enable the path of “MIN → SPK-Amp”: MINS bit = “0” → “1”
- (4) Exit the power-save-mode of Speaker-Amp: SPPSN bit = “0” → “1”
- (5) Enter the power-save-mode of Speaker-Amp: SPPSN bit = “1” → “0”
- (6) Power Down MIN-Amp and Speaker-Amp: PMMIN = PMSPK bits = “1” → “0”
- (7) Disable the path of “MIN → SPK-Amp”: MINS bit = “1” → “0”

Headphone-amp Output

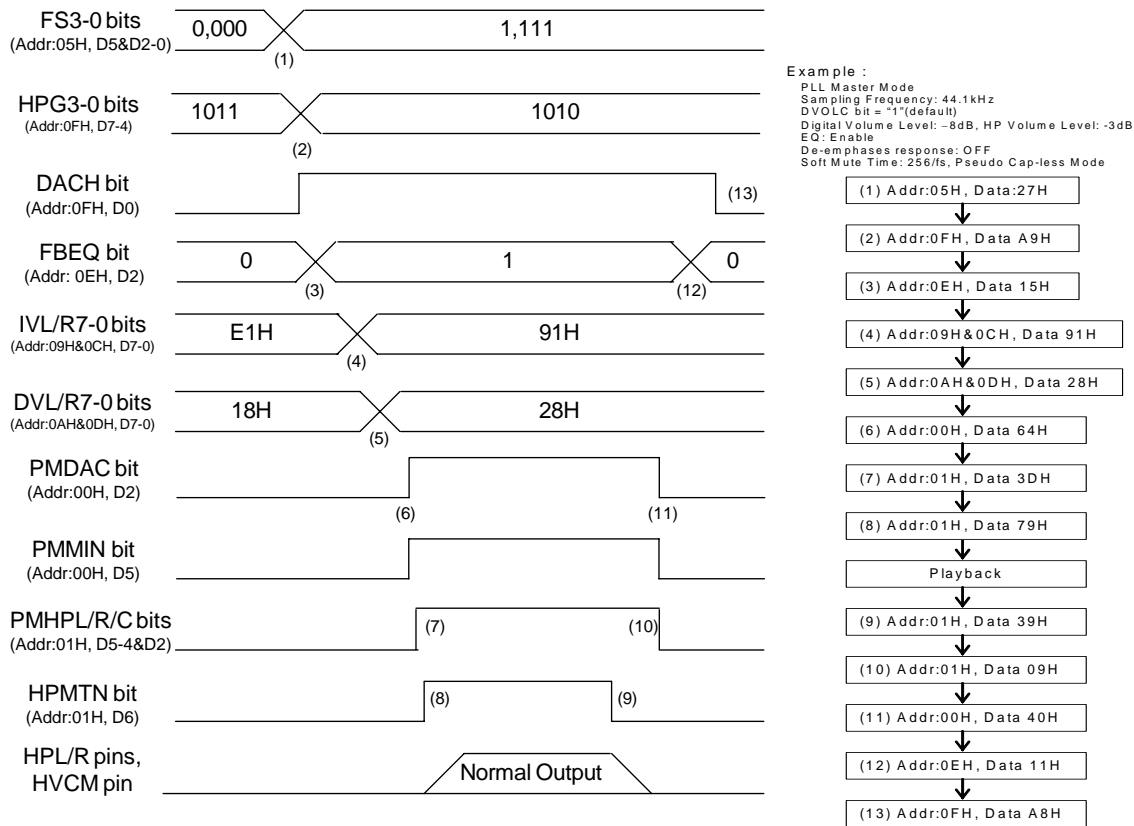

Figure 79. Headphone-Amp Output Sequence

<Example>

At first, clocks should be supplied according to “Clock Set Up” sequence.

- (1) Set up a sampling frequency (FS3-0 bits). When the AK4648 is PLL mode, DAC and Speaker-Amp should be powered-up in consideration of PLL lock time after a sampling frequency is changed.
- (2) Set up the path of “DAC → HP-Amp”: DACH bit = “0” → “1”
Set up analog volume for HP-Amp (Addr: 0F, HPG3-0 bits)
- (3) Enable 5-band Equalizer. (Boost amount is selected by Addr=25H-27H.): FBEQ bit = “0” → “1”
- (4) Set up input volume (Addr: 09H and 0CH)
When PMADL = PMADR bits = “0”, IVL7-0 and IVR7-0 bits should be set to “91H”(0dB).
- (5) Set up the output digital volume (Addr: 0AH and 0DH)
When DVOLC bit is “1” (default), DVL7-0 bits set the volume of both channels. After DAC is powered-up, the digital volume changes from default value (0dB) to the register setting value by the soft transition.
- (6) Power up DAC and MIN-Amp: PMDAC = PMMIN bits = “0” → “1”
The DAC enters an initialization cycle that starts when the PMDAC bit is changed from “0” to “1” at PMADL and PMADR bits are “0”. The initialization cycle time is $1059/fs=24ms@fs=44.1kHz$. During the initialization cycle, the DAC input digital data of both channels are internally forced to a 2's complement, “0”. The DAC output reflects the digital input data after the initialization cycle is complete. When PMADL or PMADR bit is “1”, the DAC does not require an initialization cycle. When ALC bit is “1”, ALC is disable (ALC gain is set by IVL/R7-0 bits) during an initialization cycle ($1059/fs=24ms@fs=44.1kHz$). After the initialization cycle, ALC operation starts from the gain set by IVL/R7-0 bits.
- (7) Power up headphone-amp:
 - a. Pseudo Cap-less Mode: PMHPL = PMHPR = PMHPC bits = “0” → “1”
 - b. Single-ended Mode: PMHPL=PMHPR bits = “0” → “1”
 Output voltages of headphone-amp are still VSS2.
- (8) Rise up the common voltage of headphone-amp: HPMTN bit = “0” → “1”
The rise time depends on HVDD and the capacitor value connected with the MUTET pin. When HVDD=3.3V and the capacitor value is $1.0\mu F \pm 30\%$, the time constant ($0.8 \times HVDD/2$) is $\tau_r = 120ms(\text{typ.}), 210ms(\text{max.})$. In Single-ended Mode, HVCM pin still outputs VSS2.

- (9) Fall down the common voltage of headphone-amp: HPMTN bit = "1" → "0"
The fall time depends on HVDD and the capacitor value connected with the MUTET pin. When HVDD=3.3V and the capacitor value is $1.0\mu\text{F}\pm 30\%$, the time constant is $\tau_f = 260\text{ms}(\text{max.})$.
If the power supply is powered-off or headphone-Amp is powered-down before the common voltage goes to VSS2, the pop noise occurs. It takes twice of τ_f that the common voltage goes to VSS2.
- (10) Power down headphone-amp: PMHPL = PMHPR bits = "1" → "0"
- (11) Power down DAC and MIN-Amp: PMDAC = PMMIN bits = "1" → "0"
- (12) Disable 5-band Equalizer: FB EQ bit = "1" → "0"
- (13) Disable the path of "DAC → HP-Amp": DACH bit = "1" → "0"

■ Stereo Line Output

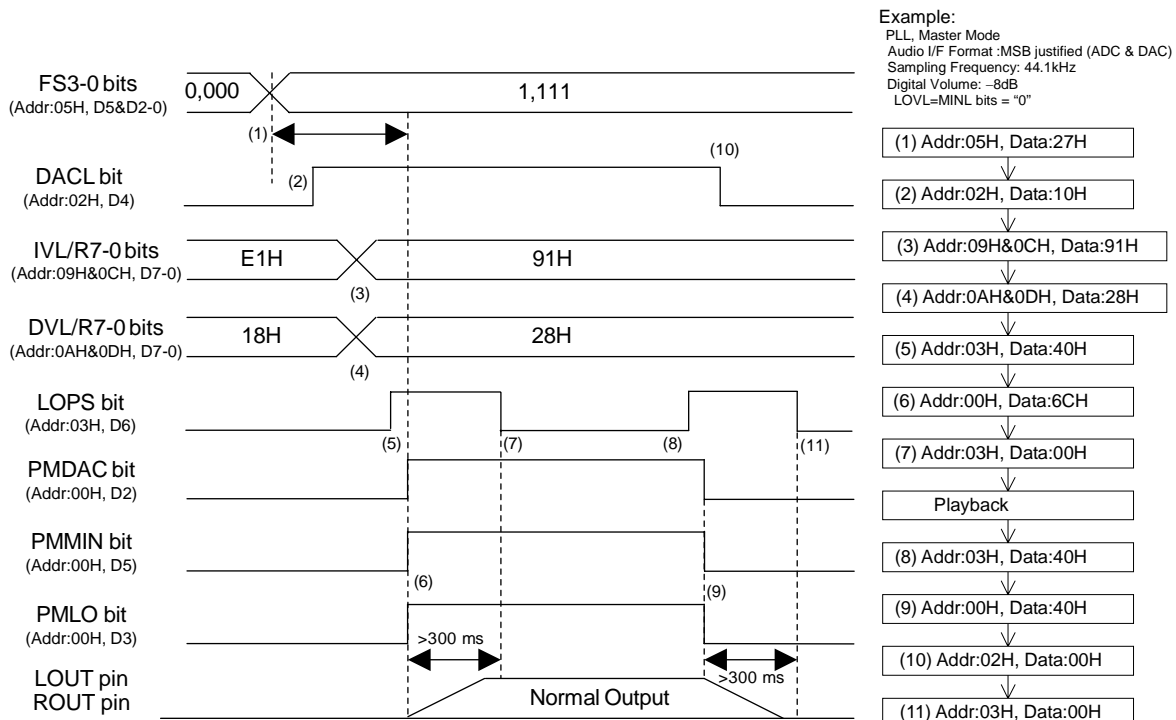

Figure 80. Stereo Lineout Sequence

<Example>

At first, clocks should be supplied according to “Clock Set Up” sequence.

- (1) Set up the sampling frequency (FS3-0 bits). When the AK4648 is PLL mode, DAC and Stereo Line-Amp should be powered-up in consideration of PLL lock time after the sampling frequency is changed.
- (2) Set up the path of “DAC → Stereo Line Amp”: DACL bit = “0” → “1”
- (3) Set up the input digital volume (Addr: 09H and 0CH)
When PMADL = PMADR bits = “0”, IVL7-0 and IVR7-0 bits should be set to “91H”(0dB).
- (4) Set up the output digital volume (Addr: 0AH and 0DH)
When DVOLC bit is “1” (default), DVL7-0 bits set the volume of both channels. After DAC is powered-up, the digital volume changes from default value (0dB) to the register setting value by the soft transition.
- (5) Enter power-save mode of Stereo Line Amp: LOPS bit = “0” → “1”
- (6) Power-up DAC, MIN-Amp and Stereo Line-Amp: PMDAC = PMMIN = PMLO bits = “0” → “1”
The DAC enters an initialization cycle that starts when the PMDAC bit is changed from “0” to “1” at PMADL and PMADR bits are “0”. The initialization cycle time is $1059/fs=24ms@fs=44.1kHz$. During the initialization cycle, the DAC input digital data of both channels are internally forced to a 2's complement, “0”. The DAC output reflects the digital input data after the initialization cycle is complete. When PMADL or PMADR bit is “1”, the DAC does not require an initialization cycle. When ALC bit is “1”, ALC is disable (ALC gain is set by IVL/R7-0 bits) during an initialization cycle ($1059/fs=24ms@fs=44.1kHz$). After the initialization cycle, ALC operation starts from the gain set by IVL/R7-0 bits.
LOUT and ROUT pins rise up to VCOM voltage after PMLO bit is changed to “1”. Rise time is 300ms(max.) at $C=1\mu F$ and $AVDD=3.3V$.
- (7) Exit power-save mode of Stereo Line-Amp: LOPS bit = “1” → “0”
LOPS bit should be set to “0” after LOUT and ROUT pins rise up. Stereo Line-Amp goes to normal operation by setting LOPS bit to “0”.
- (8) Enter power-save mode of Stereo Line-Amp: LOPS bit: “0” → “1”
- (9) Power-down DAC, MIN-Amp and Stereo Line-Amp: PMDAC = PMMIN = PMLO bits = “1” → “0”
LOUT and ROUT pins fall down to VSS1. Fall time is 300ms(max.) at $C=1\mu F$ and $AVDD=3.3V$.
- (10) Disable the path of “DAC → Stereo Line Amp”: DACL bit = “1” → “0”
- (11) Exit power-save mode of Stereo Line-Amp: LOPS bit = “1” → “0”
LOPS bit should be set to “0” after LOUT and ROUT pins fall down.

■ Stop of Clock

Master clock can be stopped when ADC and DAC are not used.

1. PLL Master Mode

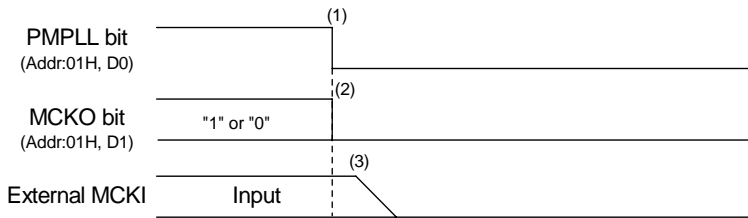

Example:

Audio I/F Format: MSB justified (ADC & DAC)
 BICK frequency at Master Mode: 64fs
 Input Master Clock Select at PLL Mode: 11.2896MHz
 Sampling Frequency: 44.1kHz

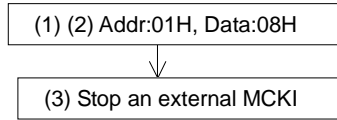
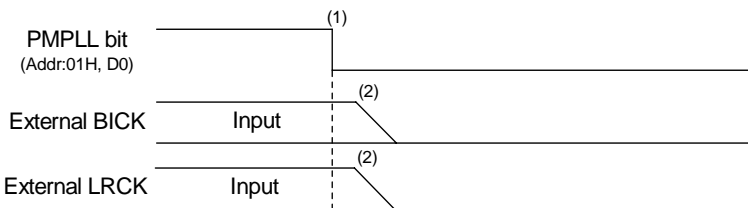

Figure 81. Clock Stopping Sequence (1)

<Example>

- (1) Power down PLL: PMPLL bit = "1" → "0"
- (2) Stop MCKO clock: MCKO bit = "1" → "0"
- (3) Stop an external master clock.

2. PLL Slave Mode (LRCK or BICK pin)



Example

Audio I/F Format: MSB justified (ADC & DAC)
 PLL Reference clock: BICK
 BICK frequency: 64fs
 Sampling Frequency: 44.1kHz

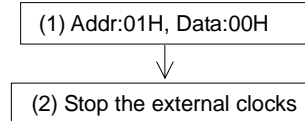
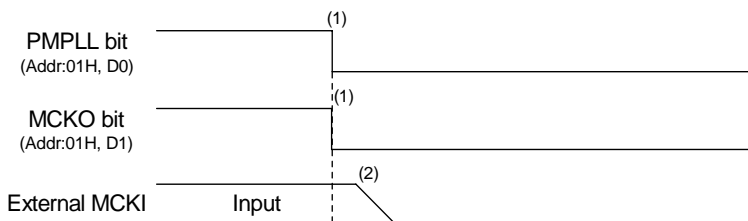

Figure 82. Clock Stopping Sequence (2)

<Example>

- (1) Power down PLL: PMPLL bit = "1" → "0"
- (2) Stop the external BICK and LRCK clocks

3. PLL Slave (MCKI pin)



Example

Audio I/F Format: MSB justified (ADC & DAC)
 PLL Reference clock: MCKI
 BICK frequency: 64fs
 Sampling Frequency: 44.1kHz

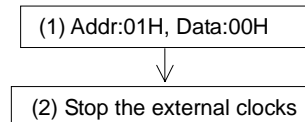

Figure 83. Clock Stopping Sequence (3)

<Example>

- (1) Power down PLL: PMPLL bit = "1" → "0"
 Stop MCKO output: MCKO bit = "1" → "0"
- (2) Stop the external master clock.

4. EXT Slave Mode

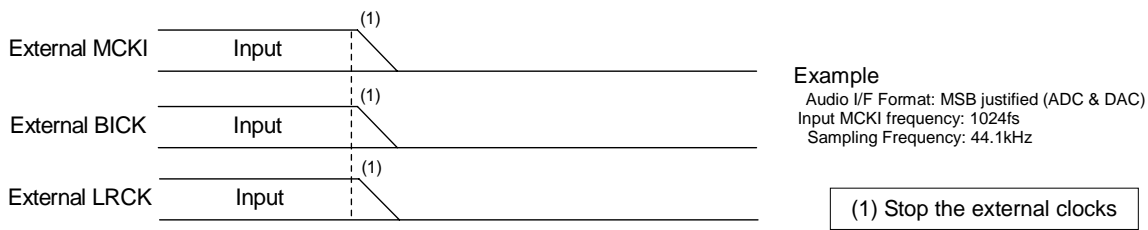

Figure 84. Clock Stopping Sequence (4)

<Example>

(1) Stop the external MCKI, BICK and LRCK clocks.

5. EXT Master Mode

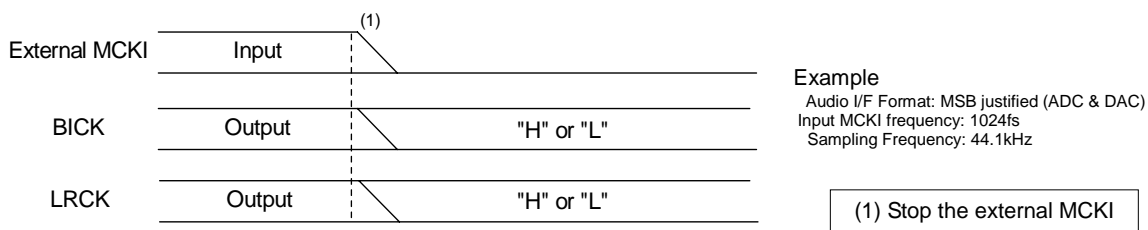

Figure 85. Clock Stopping Sequence (5)

<Example>

(1) Stop MCKI clock. BICK and LRCK are fixed to "H" or "L".

■ Power down

Power supply current can be shut down (typ. 1 μ A) by stopping clocks and setting PMVCM bit = "0" after all blocks except for VCOM are powered-down. Power supply current can be also shut down (typ. 1 μ A) by stopping clocks and setting PDN pin = "L". When PDN pin = "L", the registers are initialized.

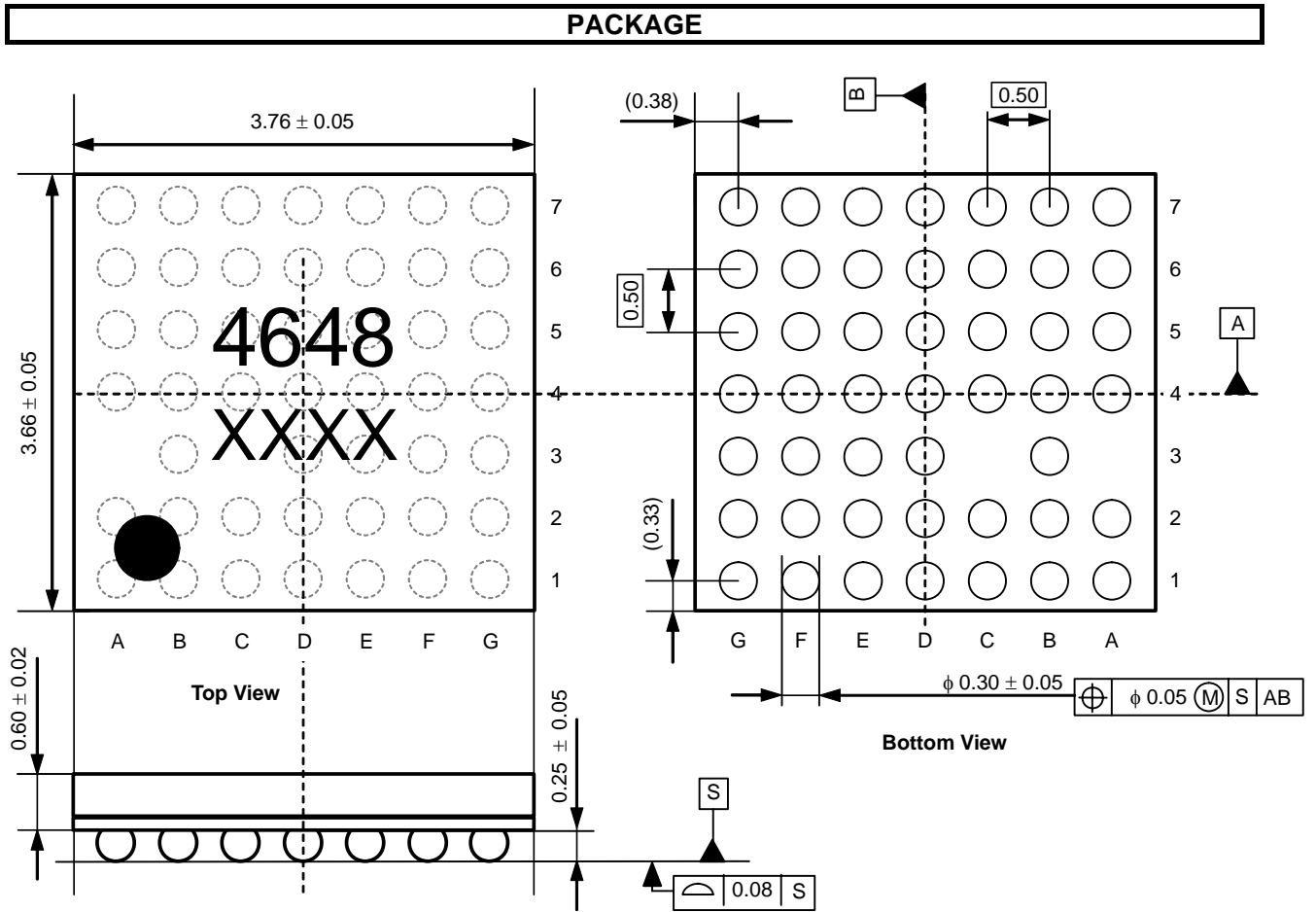

MARKING

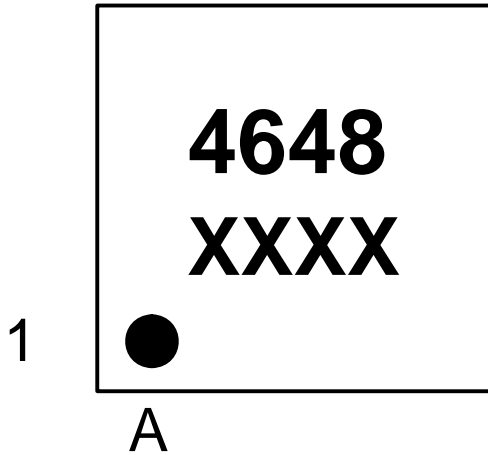

XXXX: Date code (4 digits)
Pin #A1 indication

REVISION HISTORY

Date (YY/MM/DD)	Revision	Reason	Page	Contents
07/05/25	00	First Edition		
07/06/07	01	Error Correct	1	Features: Stereo Spekaer-Amp, Output Power "1.3W @ 8Ω, HVDD=5V, Stereo SPK & Mono SPK Mode" → "1.3W @ 8Ω, HVDD=5V, Mono SPK Mode" "1.0W @ 8Ω, HVDD=4.5V, Mono SPK Mode" was added.
			15	Speaker-Amp Characteristics: S/(N+D), Po=1.3W: "Stereo SPK Mode" was deleted.

IMPORTANT NOTICE

- These products and their specifications are subject to change without notice.
When you consider any use or application of these products, please make inquiries the sales office of Asahi Kasei EMD Corporation (AKEMD) or authorized distributors as to current status of the products.
- AKEMD assumes no liability for infringement of any patent, intellectual property, or other rights in the application or use of any information contained herein.
- Any export of these products, or devices or systems containing them, may require an export license or other official approval under the law and regulations of the country of export pertaining to customs and tariffs, currency exchange, or strategic materials.
- AKEMD products are neither intended nor authorized for use as critical components_{Note1)} in any safety, life support, or other hazard related device or system_{Note2)}, and AKEMD assumes no responsibility for such use, except for the use approved with the express written consent by Representative Director of AKEMD. As used here:
 - Note1) A critical component is one whose failure to function or perform may reasonably be expected to result, whether directly or indirectly, in the loss of the safety or effectiveness of the device or system containing it, and which must therefore meet very high standards of performance and reliability.
 - Note2) A hazard related device or system is one designed or intended for life support or maintenance of safety or for applications in medicine, aerospace, nuclear energy, or other fields, in which its failure to function or perform may reasonably be expected to result in loss of life or in significant injury or damage to person or property.
- It is the responsibility of the buyer or distributor of AKEMD products, who distributes, disposes of, or otherwise places the product with a third party, to notify such third party in advance of the above content and conditions, and the buyer or distributor agrees to assume any and all responsibility and liability for and hold AKEMD harmless from any and all claims arising from the use of said product in the absence of such notification.