



AK4636

16-Bit Mono CODEC with ALC & MIC/SPK/Video-AMP

GENERAL DESCRIPTION

The AK4636 is a 16-bit mono CODEC with Microphone-Amplifier, Speaker-Amplifier and Video-Amplifier. Input circuits include a Microphone-Amplifier and an ALC (Automatic Level Control) circuit. Output circuits include a Speaker-Amplifier and Mono Line Output. Video circuits include a LPF and Video-Amplifier. The AK4636 suits a video recording/playback system of Digital Still Cameras. The AK4636 is housed in a space-saving 29-pin CSP 2.5mm x 3.0mm package (AK4636ECB) or a 32pin QFN 4.0mm x 4.0mm package (AK4636EN).

FEATURE

1. 16-Bit Delta-Sigma Mono CODEC
2. Recording Function
 - 1ch Mono Input
 - MIC Amplifier: (0dB/+3dB/+6dB/+10dB/ +17dB/+20dB/+23dB/+26dB/+29dB/+32dB)
 - Digital ALC (Automatic Level Control)
 - Output Noise Suppression
 - Setting Rate (+36dB ~ -54dB, 0.375dB Step, Mute)
 - ADC Performance (MIC-Amp=+20dB)
 - S/(N+D): 83dB
 - DR, S/N: 85dB
 - Wind-noise Reduction Filter
 - 5 band notch Filter
 - Digital Microphone Interface
3. Playback Function
 - Digital ALC (Automatic Level Control)
 - Output Noise Suppression
 - Setting Rate (+36dB ~ -54dB, 0.375dB Step, Mute)
 - Mono Line Output:
 - S/(N+D): 84dB
 - S/N: 90dB
 - Mono Speaker-Amp
 - S/(N+D): 60dB (150mW @ 8Ω)
 - BTL Output
 - Output Power: 400mW @ 8Ω (SVDD=3.3V)
 - Beep Generator
4. Video Function
 - A Composite Video Input
 - Gain Control (-1.0dB ~ +10.5dB, 0.5dB Step)
 - Low Pass Filter
 - A Video-Amp for Composite Video Signal
 - DC Direct Output
5. Power Management
6. PLL Mode:
 - Frequencies:
 - 11.2896MHz, 12MHz, 13.5MHz, 24MHz, 27MHz (MCKI pin)
 - 1fs (FCK pin)
 - 16fs, 32fs or 64fs (BICK pin)
7. EXT Mode:

- Frequencies: 256fs, 512fs or 1024fs (MCKI pin)
- 8. Sampling Rate:
 - PLL Slave Mode (FCK pin): 7.35kHz ~ 48kHz
 - PLL Slave Mode (BICK pin): 7.35kHz ~ 48kHz
 - PLL Slave Mode (MCKI pin):
 - 8kHz, 11.025kHz, 12kHz, 16kHz, 22.05kHz, 24kHz, 32kHz, 44.1kHz, 48kHz
 - PLL Master Mode:
 - 8kHz, 11.025kHz, 12kHz, 16kHz, 22.05kHz, 24kHz, 32kHz, 44.1kHz, 48kHz
 - EXT Slave Mode / EXT Master Mode:
 - 7.35kHz ~ 48kHz (256fs), 7.35kHz ~ 26kHz (512fs), 7.35kHz ~ 13kHz (1024fs)
- 9. Output Master Clock Frequency: 256fs
- 10. Serial μ P Interface: 3-wire, I²C Bus (Ver 1.0, 400kHz High Speed Mode)
- 11. Master / Slave Mode
- 12. Audio Interface Format: MSB First, 2's complement
 - ADC: DSP Mode, 16bit MSB justified, I²S
 - DAC: DSP Mode, 16bit MSB justified, 16bit LSB justified, I²S
- 13. Ta = - 30 ~ 85°C
- 14. Power Supply
 - Analog Supply (AVDD): 2.6 ~ 3.6V
 - Digital Supply (DVDD): 1.6 ~ 3.6V
 - Speaker Supply (SVDD): 2.6 ~ 3.6V
 - Video Supply (VVDD): 2.8 ~ 3.6V
- 15. Package: AK4636ECB \rightarrow 29pin CSP (2.5mm x 3.0mm, 0.5mm pitch)
 AK4636EN \rightarrow 32pin QFN (4.0mm x 4.0mm, 0.4mm pitch)

■ Block Diagram

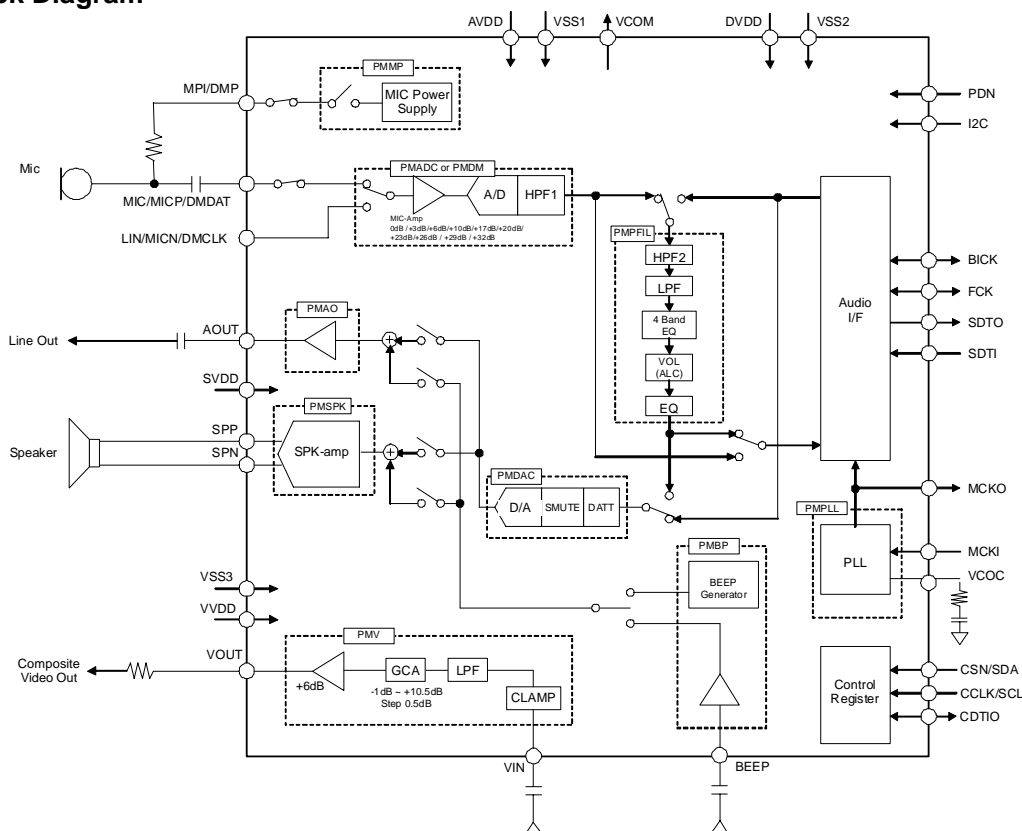

Figure 1. AK4636 Block Diagram

■ **Ordering Guide**

AK4636ECB	-30 ~ +85°C	29pin CSP (2.5mmx3.0mm 0.5mm pitch)
AK4636EN	-30 ~ +85°C	32pin QFN (4.0mmx4.0mm 0.4mm pitch)
AKD4636	AK4636ECB Evaluation Board	

■ **Pin Layout**

AK4636ECB

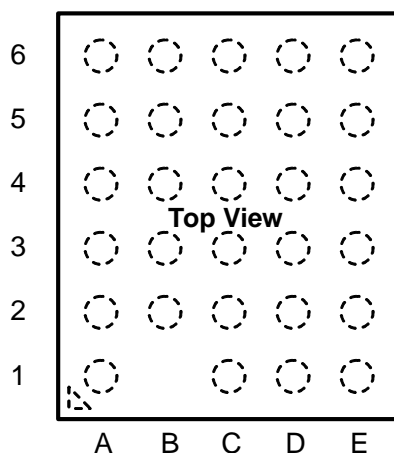

6	PDN	DVDD	VSS2	SPP	SVDD
5	SDTO	MCKO	SDTI	VSS3	SPN
4	BICK	MCKI	FCK	AOUT	BEEP
3	CCLK/SCL	CDTIO	I2C	MIC/MICP/ DMDAT	LIN/MICN/ DMCLK
2	CSN/SDA	VOUT	VVDD	VCOM	MPI/DMP
1	VIN		VSS1	AVDD	VCOC
	A	B	C	D	E

Top View

AK4636EN

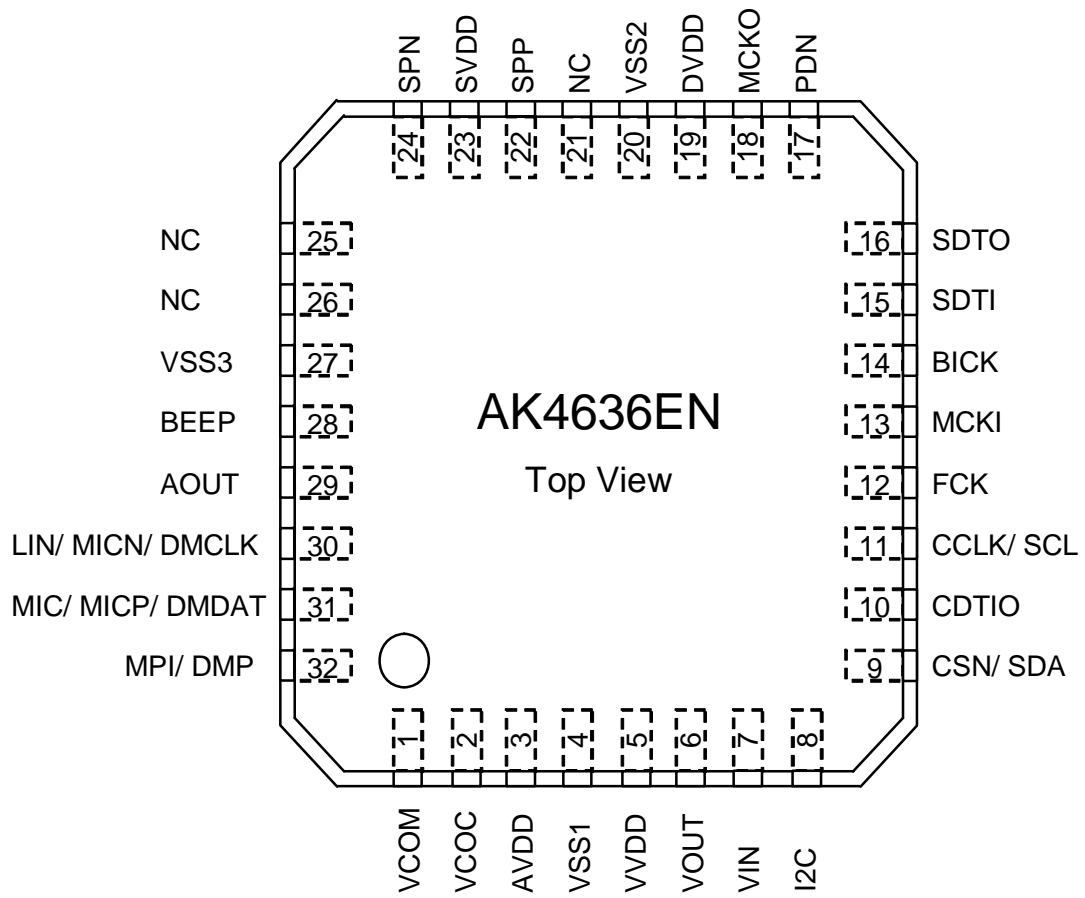

PIN/FUNCTION			
AK4636ECB			
No.	Pin Name	I/O	Function
D2	VCOM	O	Common Voltage Output Pin = 1.15V(typ) Bias voltage of ADC inputs and DAC outputs.
E1	VCOG	O	Output Pin for Loop Filter of PLL Circuit This pin must be connected to VSS1 with one resistor and capacitor in series.
D1	AVDD	-	Analog Power Supply Pin
C1	VSS1	-	Ground Pin
C2	VVDD	-	Video Amp Power Supply Pin
B2	VOU	O	Composite Video Signal Driver Pin
A1	VIN	I	Composite Video Signal Input Pin
C3	I2C	I	Control Mode Select Pin "H": I ² C Bus, "L": 3-wire Serial
A2	CSN	I	Chip Select Pin (I2C pin = "L")
	SDA	I/O	Control Data Input/Output Pin (I2C pin = "H")
B3	CDTIO	I/O	Control Data Input/Output Pin (I2C pin = "L") This pin must be connected to the ground. (I2C pin = "H")
	CCLK	I	Control Data Clock Pin (I2C pin = "L")
A3	SCL	I	Control Data Clock Pin (I2C pin = "H")
	FCK	I/O	Frame Clock Pin
B4	MCKI	I	External Master Clock Input Pin
A4	BICK	I/O	Audio Serial Data Clock Pin
C5	SDTI	I	Audio Serial Data Input Pin
A5	SDTO	O	Audio Serial Data Output Pin
A6	PDN	I	Power-down & Reset When "L", the AK4636 is in power-down mode and is held in reset. The AK4636 must be always reset upon power-up.
B5	MCKO	O	Master Clock Output Pin
B6	DVDD	-	Digital Power Supply Pin
C6	VSS2	-	Ground Pin.
D6	SPP	O	Speaker Amp Positive Output Pin
E6	SVDD	-	Speaker Amp Power Supply Pin
E5	SPN	O	Speaker Amp Negative Output Pin
E4	BEEP	I	Beep Signal Input Pin
D5	VSS3	-	Ground Pin
D4	AOUT	O	Mono Line Output Pin
E3	LIN	I	Line Input Pin for Single Ended Input (MDIF bit = "0", DMIC bit = "0")
	MICN	I	Microphone Negative Input Pin for Differential Input (MDIF bit = "1", DMIC bit = "0")
	DMCLK	I	Digital Microphon Clock pin (DMIC bit = "1")
D3	MIC	I	Microphone Input Pin for Single Ended Input (MDIF bit = "0", DMIC bit = "0")
	MICP	I	Microphone Positive Input Pin for Differential Input (MDIF bit = "1" DMIC bit = "0")
	DMDAT	O	Digital Microphone Data Input pin (DMIC bit = "1")
E2	MPI	O	MIC Power Supply Pin for Microphone (DMPE bit = "0")
	DMP	O	MIC Power Supply pin for Digital Microphone (DMPE bit = "1")

AK4636EN

No.	Pin Name	I/O	Function
1	VCOM	O	Common Voltage Output Pin = 1.15V(typ) Bias voltage of ADC inputs and DAC outputs.
2	VCOC	O	Output Pin for Loop Filter of PLL Circuit This pin must be connected to VSS1 with one resistor and capacitor in series.
3	AVDD	-	Analog Power Supply Pin
4	VSS1	-	Ground Pin
5	VVDD	-	Video Amp Power Supply Pin
6	VOUT	O	Composite Video Signal Driver Pin
7	VIN	I	Composite Video Signal Input Pin
8	I2C	I	Control Mode Select Pin "H": I ² C Bus, "L": 3-wire Serial
9	CSN	I	Chip Select Pin (I2C pin = "L")
	SDA	I/O	Control Data Input/Output Pin (I2C pin = "H")
10	CDTIO	I/O	Control Data Input/Output Pin (I2C pin = "L")
			This pin must be connected to the ground. (I2C pin = "H")
11	CCLK	I	Control Data Clock Pin (I2C pin = "L")
	SCL	I	Control Data Clock Pin (I2C pin = "H")
12	FCK	I/O	Frame Clock Pin
13	MCKI	I	External Master Clock Input Pin
14	BICK	I/O	Audio Serial Data Clock Pin
15	SDTI	I	Audio Serial Data Input Pin
16	SDTO	O	Audio Serial Data Output Pin
17	PDN	I	Power-down & Reset When "L", the AK4636EN is in power-down mode and is held in reset. The AK4636EN must always be reset upon power-up.
18	MCKO	O	Master Clock Output Pin
19	DVDD	-	Digital Power Supply Pin
20	VSS2	-	Ground Pin.
21	NC	-	No Connection. No internal bonding. This pin must be connected to the ground.
22	SPP	O	Speaker Amp Positive Output Pin
23	SVDD	-	Speaker Amp Power Supply Pin
24	SPN	O	Speaker Amp Negative Output Pin
25	NC	-	No Connection. No internal bonding. This pin must be connected to the ground.
26	NC	-	No Connection. No internal bonding. This pin must be connected to the ground.
27	VSS3	-	Ground Pin
28	BEEP	I	Beep Signal Input Pin
29	AOUT	O	Mono Line Output Pin
30	LIN	I	Line Input Pin for Single Ended Input (MDIF bit = "0", DMIC bit = "0")
	MICN	I	Microphone Negative Input Pin for Differential Input (MDIF bit = "1", DMIC bit = "0")
	DMCLK	O	Digital Microphone Clock pin (DMIC bit = "1")
31	MIC	I	Microphone Input Pin for Single Ended Input (MDIF bit = "0", DMIC bit = "0")
	MICP	I	Microphone Positive Input Pin for Differential Input (MDIF bit = "1", DMIC bit = "0")
	DMDAT	I	Digital Microphon Data Input pin (DMIC bit = "1")
32	MPI	O	MIC Power Supply Pin for Microphone (DMPE bit = "0")
	DMP	O	MIC Power Supply pin for Digital Microphone (DMPE bit = "1")

Note: All input pins except analog input pins (MIC/MICP/DMDAT, LIN/MICN/DMCLK, VIN, BEEP pins) must not be left floating.

■ Handling of Unused Pin

The unused I/O pins must be processed appropriately as below.

Classification	Pin Name	Setting
Analog	MIC/MICP, LIN/MICN, MPI, AOUT, SPP, SPN, VCOC, VIN, VOUT	These pins must be open.
Digital	MCKI, SDTI	These pins must be connected to VSS2.
	CDTIO	When I2C pin = "H", These pins should be connected to VSS2.
	MCKO, SDTO	These pins must be open.

ABSOLUTE MAXIMUM RATINGS

(VSS=VSS2=VSS3=0V; Note 1)

Parameter	Symbol	min	max	Units	
Power Supplies:	Analog	AVDD	-0.3	4.6	V
	Digital	DVDD	-0.3	4.6	V
	Speaker-Amp	SVDD	-0.3	4.6	V
	Video-Amp	VVDD	-0.3	4.6	V
Input Current, Any Pin Except Supplies	IIN	-	±10	mA	
Analog Input Voltage (Note 2)	VINA	-0.3	AVDD+0.3	V	
Digital Input Voltage (Note 3)	VIND	-0.3	DVDD+0.3	V	
Video-amp Input Voltage (Note 4)	VINV	-0.3	VVDD+0.3	V	
Ambient Temperature (powered applied)	Ta	-30	85	°C	
Storage Temperature	Tstg	-65	150	°C	
Maximum Power Dissipation (Note 5)	Pd	-	450	mW	

Note 1. All voltages with respect to ground. VSS21, VSS2 and VSS3 must be connected to the same analog ground plane.

Note 2. LIN/MICN/DMCLK, MIC/MICP/DMDAT, BEEP pins

Note 3. PDN, I2C, CSN/SDA, CCLK/SCL, CDTIO, SDTI, FCK, BICK, MCKI pins

Pull-up resistors at SDA and SCL pins should be connected to (DVDD+0.3)V or less voltage.

Note 4. VIN pin

Note 5. AK4636ECB: When PCB wiring density is more than 200% and superficial layer wiring density is more than 50%. AK4636EN: When PCB wiring density is more than 100%.

This power is the AK4636 internal dissipation that does not include power of externally connected speakers.

WARNING: Operation at or beyond these limits may result in permanent damage to the device.

Normal operation is not guaranteed at these extremes.

RECOMMENDED OPERATING CONDITIONS

(VSS=VSS2=VSS3=0V; [Note 1](#))

Parameter		Symbol	min	typ	max	Units
Power Supplies (Note 6)	Analog	AVDD	2.6	3.3	3.6	V
	Digital	DVDD	1.6	3.3	3.6	V
	Speaker-Amp	SVDD	2.6	3.3	3.6	V
	Video-Amp	VVDD	2.8	3.3	3.6	V

Note 1. All voltages with respect to ground.

Note 6. The power up sequence between AVDD, DVDD, SVDD and VVDD is not critical. The internal circuit is invalid when power up the AK4636 at the PDN pin = "H". Set the PDN pin to "L" to reset the internal circuit after power up. To avoid an internal circuit error, the PDN pin must be "L" upon power up, and changed to "H" after all power supplies are supplied. The AK4636 can not be partially powered-off, all powers must be ON.

(Power-off state is identified as when the power supplies are floating or short to ground.) When connecting the AK4636 to the I2C bus, do not turn the AK4636 off unless other external devices are off.

* AKM assumes no responsibility for the usage beyond the conditions in this datasheet.

ANALOG CHARACTERISTICS

(Ta=25°C; AVDD=DVDD=SVDD = 3.3V, VVDD = 3.3V, VSS1=VSS2=VSS3 = 0V; fs = 8kHz; LP bit = "1"
BICK = 64fs; Signal Frequency = 1kHz; 16bit Data; Measurement frequency = 20Hz ~ 3.4kHz; EXT Slave Mode; unless otherwise specified)

Parameter		min	typ	max	Units
MIC Amplifier: MIC, LIN pins ; MDIF bit = "0"; (Single-ended input)					
Input Resistance		20	30	40	kΩ
Gain	(MGAIN3-0 bits = "0000")	-	0	-	dB
	(MGAIN3-0 bits = "0001")	19	20	21	dB
	(MGAIN3-0 bits = "0010")	25	26	27	dB
	(MGAIN3-0 bits = "0011")	31	32	33	dB
	(MGAIN3-0 bits = "0100")	9	10	11	dB
	(MGAIN3-0 bits = "0101")	16	17	18	dB
	(MGAIN3-0 bits = "0110")	22	23	24	dB
	(MGAIN3-0 bits = "0111")	28	29	30	dB
	(MGAIN3-0 bits = "1000")	2	3	4	dB
(MGAIN3-0 bits = "1001")	5	6	7	dB	
MIC Amplifier: MICP, MICN pins ; MDIF bit = "1"; (Full-differential input)					
Input Voltage (Note 7)	(MGAIN3-0 bits = "0001")	0.128	0.150	0.173	Vpp
	(MGAIN3-0 bits = "0010")	0.064	0.075	0.086	Vpp
	(MGAIN3-0 bits = "0011")	0.032	0.038	0.044	Vpp
	(MGAIN3-0 bits = "0100")	0.403	0.474	0.545	Vpp
	(MGAIN3-0 bits = "0101")	0.180	0.212	0.244	Vpp
	(MGAIN3-0 bits = "0110")	0.090	0.106	0.122	Vpp
	(MGAIN3-0 bits = "0111")	0.045	0.053	0.061	Vpp
	(MGAIN3-0 bits = "1001")	0.639	0.752	0.864	Vpp
MIC Power Supply: MPI pin					
Output Voltage		2.1	2.3	2.5	V
Load Resistance		2	-	-	kΩ
Load Capacitance		-	-	30	pF
ADC Analog Input Characteristics: MIC/LIN → ADC, MIC Gain = +20dB, IVOL = 0dB, ALC1bit = "0"					
Resolution		-	-	16	Bits
Input Voltage (MIC Gain=20dB)		0.128	0.150	0.173	Vpp
S/(N+D) (-1dBFS) (Note 8)		73	83	-	dB
D-Range (-60dBFS)		74	85	-	dB
S/N		74	85	-	dB
ADC Analog Input Characteristics: MIC/LIN → ADC, MIC Gain = 0dB, IVOL = 0dB, ALC1bit = "0"					
Resolution		-	-	16	Bits
Input Voltage (MIC Gain=0dB)		1.28	1.50	1.73	Vpp
S/(N+D) (-1dBFS) (Note 8)		73	83	-	dB
D-Range (-60dBFS)		78	89	-	dB
S/N		78	89	-	dB
DAC Characteristics:					
Resolution				16	Bits
Mono Line Output Characteristics: AOUT pin, DAC → AOUT, RL = 10kΩ, LOVL bit = "0"					
Output Voltage	LOVL bit = "0"	1.28	1.50	1.73	Vpp
	LOVL bit = "1"(Note 9)	-	2.12	-	Vpp
S/(N+D) (0dBFS) (Note 8)		74	84	-	dB
D-Range (-60dBFS)		80	90	-	dB
S/N		80	90	-	dB
Load Resistance		10	-	-	kΩ
Load Capacitance		-	-	30	pF

Parameter		min	typ	max	Units
Speaker-Amp Characteristics: DAC → SPP/SPN pins, ALC2 bit = "0", $R_L=8\Omega$, BTL, SVDD=3.3V					
Output Voltage (Note 10)	SPKG1-0 bits = "00" (-4.1dBFS)	2.54	3.17	3.80	Vpp
	SPKG1-0 bits = "01" (-4.1dBFS)	3.20	4.00	4.80	Vpp
S/(N+D)	When output 150mW	40	60	-	dB
	When output 400mW	-	20	-	dB
Output Noise Level	SPKG1-0 bits = "00"	-	-84	-	dBV
	SPKG1-0 bits = "01"	-	-82	-72	dBV
	SPKG1-0 bits = "10"	-	-80	-	dBV
Load Resistance		8	-	-	Ω
Load Capacitance		-	-	30	pF
BEEP Input: BEEP pin, Internal Resistance mode (BPM1-0 bits = "01")					
Input Resistance		23	33	43	k Ω
Maximum Input Voltage		-	1.50	-	Vpp
Output Voltage (Input Voltage=0.5Vpp)					
BEEP → SPP/SPN (BPLVL 2-0 bits = 0H) (SPKG1-0 bits = "00")		1.35	1.69	2.03	Vpp
	BEEP → AOUT (BPLVL 2-0 bits = 0H) (LOVL bit = "0")	0.40	0.50	0.60	Vpp
BEEP Input: BEEP pin, External Resistance mode (BPM1-0 bits = "10") Input Resistance= 33k Ω					
Maximum Input Voltage (Note 11)		-	1.50	-	Vpp
Output Voltage (Input Voltage=0.5Vpp)					
BEEP → SPP/SPN (BPLVL 2-0 bits = 0H) (SPKG1-0 bits = "00")		-	1.69	-	Vpp
	BEEP → AOUT (BPLVL 2-0 bits = 0H) (LOVL bit = "0")	-	0.50	-	Vpp
Video Signal Input:					
Maximum Input Voltage (Note 12), (GCA = 0dB)		-	1.2	-	Vpp
Pull Down Current		-	1	-	μ A
Video Signal Output:					
Output Gain (Note 13) VIN=100kHz (GCA = 0dB)		5.3	6.0	6.7	dB
Maximum Output Voltage (Note 13)		2.4	-	-	Vpp
Output Clamp Voltage (Note 13)		-	50	100	mV
S/N (Note 13) 100kHz ~ 6MHz (GCA = 0dB)		-	66	-	dB
Secondary harmonic distortion (Note 13, Note 14) VIN = 3.58MHz, 0.2Vpp (GCA = 0dB, Sin Wave)		-	-42	-	dB
Load Resistance		140	150	-	Ω
Load Capacitance	C _{L1} (Figure 3)	-	-	15	pF
	C _{L2} (Figure 3)	-	-	400	pF
LPF: (Note 13, Note 14)					
Frequency Response Input=0.2Vpp, Sin Wave (0dB at 100kHz)	Response at 6.75MHz	-3.0	-0.5	-	dB
	Response at 27MHz	-	-40	-20	dB
Frequency Response Input=0.2Vpp, Sin Wave (+6dB at 100kHz)	Response at 6.75MHz	-	-0.5	-	dB
	Response at 27MHz	-	-40	-	dB
Group Delay	GD3MHz-GD6MHz	-	10	100	ns
GCA Characteristics:					
Step Width GCA = -1.0dB ~ +10.5dB		0.1	0.5	0.9	dB

Parameter	min	typ	max	Units	
Power Supplies					
Power Up (PDN = "H")					
All Circuit Power-up: (Note 15)					
AVDD+DVDD	fs=8kHz (LP bit = "1") (Note 17)	-	7	-	mA
	fs=48kHz(LP bit = "0") (Note 17)	-	11	17	mA
SVDD: Speaker-Amp Normal Operation (SPPSN bit = "1", No Output)					
		-	4	12	mA
VVDD (Note 16)					
		-	8	12	mA
Power Down (PDN = "L") (Note 18)					
AVDD+DVDD+SVDD+VVDD					
		-	1	5	μA

Note 7. The voltage difference between MICP and MICN pins. AC coupling capacitor should be inserted in series at each input pin. Full-differential microphone input is not available at MGAIN3-0 bits = "1000" or "0000". If the input signal over those maximum voltages are input, the ADC does not operate properly.

Note 8. When a PLL reference clock is input to the FCK pin in PLL Slave Mode, S/ (N+D) of MIC→ADC is 75dB (typ), S/ (N+D) of DAC→AOUT is 75dB (typ).

Note 9. When LOVL bit = "1", large-amplitude output may have clip noise.

Note 10. When SPGK1-0 bits = "01" or "10", large-amplitude output may have clip noise if the SVDD is low.

Note 11. The maximum input voltage is inversely proportional to the external input resistance (Rin). $V_{out} = V_{in} \times R_{in}/33k\Omega(\max)$. The volume can not be changed by BPLVL 7-0 bits in "BEEP pin External Input Resistance Mode" (BPM1-0 bits = "10"). BPLVL 7-0 bits should be fixed "00H" to change the gain by the external resistance (Rin).

Note 12. Input Voltage does not depend on VVDD voltage.

Note 13. Measurement point is A of Figure 2.

Note 14. This is the value when the lowest input signal level is more than -20IRE.

Note 15. When PLL Master Mode (MCKI=12MHz), and PMV = PMMP = PMADC = PMDAC = PMPFIL = PMSPK = PMVCM = PMPLL = MCKO = PMAO = M/S = "1". The MPI pin outputs 0mA. In EXT mode, when PMPLL= MCKO= M/S= "0" and LP= "0", AVDD+ DVDD= 6mA (fs=8kHz, typ) or 9mA (fs=48kHz, typ), when LP= "1", AVDD+DVDD = 5mA (fs=8kHz, typ).

Note 16. When Black signal is input to the VIN pin, and the VOUT pin has no load resistance. If the resistance is 150Ω, it is 12.5mA(typ).

Note 17. Set LP bit = "1" when sampling frequency ≤ 22.05kHz, set LP bit = "0" when > 22.05kHz.

Note 18. All digital input pins are fixed to DVDD or VSS2.

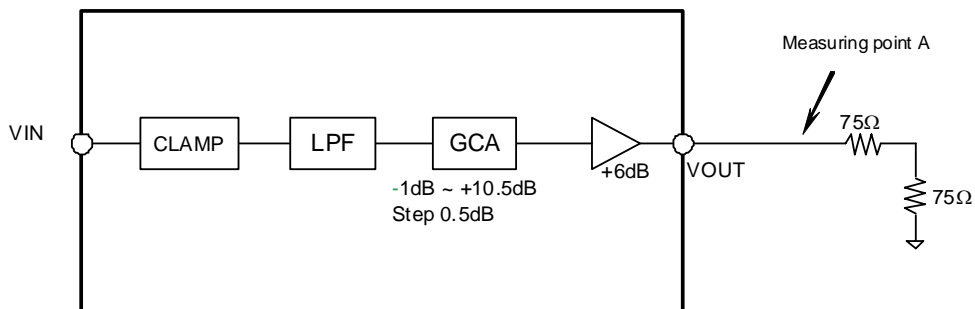

Figure 2. Measurement Point

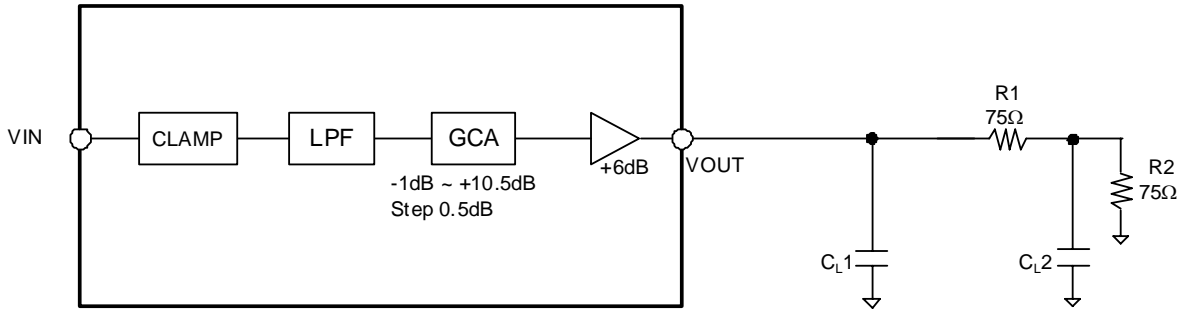

Figure 3. Load Capacitance C_{L1} and C_{L2}

FILTER CHARACTERISTICS							
(Ta = -30 ~ 85°C; AVDD = 2.6 ~ 3.6V, DVDD = 1.6 ~ 3.6V, SVDD = 2.6 ~ 3.6V, VVDD = 2.8 ~ 3.6V; fs = 8kHz)							
Parameter	Symbol	min	typ	max	Units		
ADC Digital Filter (Decimation LPF):							
Passband (Note 19)	±0.16dB	PB	0	-	3.0	kHz	
	-0.66dB		-	3.5	-	kHz	
	-1.1dB		-	3.6	-	kHz	
	-6.9dB		-	4.0	-	kHz	
Stopband (Note 19)	SB	4.7	-	-	kHz		
Passband Ripple	PR	-	-	±0.1	dB		
Stopband Attenuation	SA	73	-	-	dB		
Group Delay (Note 20)	GD	-	16	-	1/fs		
Group Delay Distortion	ΔGD	-	0	-	μs		
DAC Digital Filter (Decimation LPF):							
Passband (Note 19)	±0.16dB	PB	0	-	3.0	kHz	
	-0.54dB		-	3.5	-	kHz	
	-1.0dB		-	3.6	-	kHz	
	-6.7dB		-	4.0	-	kHz	
Stopband (Note 19)	SB	4.7	-	-	kHz		
Passband Ripple	PR	-	-	±0.1	dB		
Stopband Attenuation	SA	73	-	-	dB		
Group Delay (Note 20)	GD	-	16	-	1/fs		
Group Delay Distortion	ΔGD	-	0	-	μs		
DAC Digital Filter + Analog Filter:							
Frequency Response: 0 ~ 3.4kHz	FR	-	±1.0	-	dB		

Note 19. The passband and stopband frequencies are proportional to fs (system sampling rate).

For example, ADC of PB = 3.6kHz is 0.45*fs (@ -1.0dB). A reference of frequency response is 1kHz.

Note 20. The calculated delay time caused by digital filtering. This time is from the input of analog signal to setting of the 16-bit data of a channel from the input register to the output register of the ADC. For the DAC, this time is from setting the 16-bit data of a channel from the input register to the output of analog signal. When there is not a phase change with the IIR filter, group delay of the programmable filter (primary HPF + primary LPF + 4-band Equalizer + ALC) increases for 3/fs than a value above mentioned.

DC CHARACTERISTICS						
(Ta = -30 ~ 85°C; AVDD = 2.6 ~ 3.6V, DVDD = 1.6 ~ 3.6V, SVDD = 2.6 ~ 3.6V, VVDD = 2.8 ~ 3.6V)						
Parameter	Symbol	min	typ	max	Units	
Audio Interface & Serial μP Interface (CDTIO, CSN/SDA, CCLK/SCL, I2C, PDN, BICK, FCK, SDTI, MCKI pins Input)						
High-Level Input Voltage (DVDD \geq 2.2V)	V _{IH}	70% DVDD	-	-	V	
(DVDD < 2.2V)		80% DVDD	-	-	V	
Low-Level Input Voltage (DVDD \geq 2.2V)	V _{IL}	-	-	30% DVDD	V	
(DVDD < 2.2V)		-	-	20% DVDD	V	
Audio Interface & Serial μP Interface (CDTIO, SDA MCKO, BICK, FCK, SDTO pins Output)						
High-Level Output Voltage (I _{out} = -80 μ A)	V _{OH}	DVDD-0.2	-	-	V	
Low-Level Output Voltage (Except SDA pin : I _{out} = 80 μ A)	V _{OL1}	-	-	0.2	V	
(SDA pin, 2.0V \leq DVDD \leq 3.6V: I _{out} = 3mA)	V _{OL2}	-	-	0.4	V	
(SDA pin, 1.6V \leq DVDD < 2.0V: I _{out} = 3mA)	V _{OL2}	-	-	20% DVDD	V	
Input Leakage Current	I _{in}	-	-	\pm 10	μ A	
Digital MIC Interface (DMDAT pin Input ; DMIC bit = "1")						
High-Level Input Voltage	V _{IH2}	65% AVDD	-	-	V	
Low-Level Input Voltage	V _{IL2}	-	-	35% AVDD	V	
Digital MIC Interface (DMCLK pin Output ; DMIC bit = "1")						
High-Level Output Voltage (I _{out} = -80 μ A)	V _{OH3}	AVDD-0.4	-	-	V	
Low-Level Output Voltage (I _{out} = 80 μ A)	V _{OL3}	-	-	0.4	V	
Input Leakage Current	I _{in}	-	-	\pm 10	μ A	

SWITING CHARACTERISTICS						
(Ta = -30 ~ 85°C; AVDD = 2.6 ~ 3.6V, DVDD = 1.6 ~ 3.6V, SVDD = 2.6 ~ 3.6V, VVDD = 2.8 ~ 3.6V; C _L = 20pF)						
Parameter	Symbol	min	typ	max	Units	
PLL Master Mode (PLL Reference Clock = MCKI pin) (Figure 4)						
MCKI Input: Frequency	f _{CLK}	11.2896	-	27.0	MHz	
Pulse Width Low	t _{CLKL}	0.4/f _{CLK}	-	-	ns	
Pulse Width High	t _{CLKH}	0.4/f _{CLK}	-	-	ns	
MCKO Output:						
Frequency	f _{MCK}	-	256 x f _{FCK}	-	kHz	
Duty Cycle except f _s = 29.4kHz, 32kHz	d _{MCK}	40	50	60	%	
f _s = 29.4kHz, 32kHz (Note 22)	d _{MCK}	-	33	-	%	
FCK Output: Frequency	f _{FCK}	8	-	48	kHz	
Pulse width High (DIF1-0 bits = "00" and FCKO bit = "1")	t _{FCKH}	-	t _{BCK}	-	ns	
Duty Cycle (DIF1-0 bits = "00" or FCKO bit = "0")	d _{FCK}	-	50	-	%	
BICK: Period (BCKO1-0 bit = "00")	t _{BCK}	-	1/16f _{FCK}	-	ns	
(BCKO1-0 bit = "01")	t _{BCK}	-	1/32f _{FCK}	-	ns	
(BCKO1-0 bit = "10")	t _{BCK}	-	1/64f _{FCK}	-	ns	
Duty Cycle	d _{BCK}	-	50	-	%	

Parameter	Symbol	min	typ	max	Units
Audio Interface Timing					
DSP Mode: (Figure 5, Figure 6)					
FCK “↑” to BICK “↑” (Note 23)	tDBF	0.5 x tBCK -40	0.5 x tBCK	0.5 x tBCK + 40	ns
FCK “↑” to BICK “↓” (Note 24)	tDBF	0.5 x tBCK -40	0.5 x tBCK	0.5 x tBCK +40	ns
BICK “↑” to SDTO (BCKP bit = “0”)	tBSD	-70	-	70	ns
BICK “↓” to SDTO (BCKP bit = “1”)	tBSD	-70	-	70	ns
SDTI Hold Time	tSDH	50	-	-	ns
SDTI Setup Time	tSDS	50	-	-	ns
Except DSP Mode: (Figure 7)					
BICK “↓” to FCK Edge	tBFCK	-40	-	40	ns
FCK to SDTO (MSB) (Except I ² S mode)	tFSD	-70	-	70	ns
BICK “↓” to SDTO	tBSD	-70	-	70	ns
SDTI Hold Time	tSDH	50	-	-	ns
SDTI Setup Time	tSDS	50	-	-	ns
PLL Slave Mode (PLL Reference Clock: FCK pin) (Figure 8, Figure 9)					
FCK: Frequency	fFCK	7.35	8	48	kHz
DSP Mode: Pulse Width High	tFCKH	tBCK-60	-	1/fFCK-tBCK	ns
Except DSP Mode: Duty Cycle	duty	45	-	55	%
BICK: Period	tBCK	1/64fFCK	-	1/16fFCK	ns
Pulse Width Low	tBCKL	0.4 x tBCK	-	-	ns
Pulse Width High	tBCKH	0.4 x tBCK	-	-	ns
PLL Slave Mode (PLL Reference Clock: BICK pin) (Figure 8, Figure 9)					
FCK: Frequency	fFCK	7.35	8	48	kHz
DSP Mode: Pulse width High	tFCKH	tBCK-60	-	1/fFCK-tBCK	ns
Except DSP Mode: Duty Cycle	duty	45	-	55	%
BICK: Period (PLL3-0 bit = “0001”)	tBCK	-	1/16fFCK	-	ns
(PLL3-0 bit = “0010”)	tBCK	-	1/32fFCK	-	ns
(PLL3-0 bit = “0011”)	tBCK	-	1/64fFCK	-	ns
Pulse Width Low	tBCKL	0.4 x tBCK	-	-	ns
Pulse Width High	tBCKH	0.4 x tBCK	-	-	ns
PLL Slave Mode (PLL Reference Clock: MCKI pin) (Figure 10)					
MCKI Input: Frequency	fCLK	11.2896	-	27.0	MHz
Pulse Width Low	fCLKL	0.4/fCLK	-	-	ns
Pulse Width High	fCLKH	0.4/fCLK	-	-	ns
MCKO Output:					
Frequency	fMCK	-	256 x fFCK	-	kHz
Duty Cycle except fs=29.4kHz, 32kHz	dMCK	40	50	60	%
fs=29.4kHz, 32kHz (Note 22)	dMCK	-	33	-	%
FCK: Frequency	fFCK	8	-	48	kHz
DSP Mode: Pulse width High	tFCKH	tBCK-60	-	1/fFCK-tBCK	ns
Except DSP Mode: Duty Cycle	duty	45	-	55	%
BICK: Period	tBCK	1/64fFCK	-	1/16fFCK	ns
Pulse Width Low	tBCKL	0.4 x tBCK	-	-	ns
Pulse Width High	tBCKH	0.4 x tBCK	-	-	ns

Parameter	Symbol	min	typ	max	Units
Audio Interface Timing					
DSP Mode: (Figure 11, Figure 12)					
FCK “↑” to BICK “↑” (Note 23)	tFCKB	0.4 x tBCK	-	-	ns
FCK “↑” to BICK “↓” (Note 24)	tFCKB	0.4 x tBCK	-	-	ns
BICK “↑” to FCK “↑” (Note 23)	tBFCK	0.4 x tBCK	-	-	ns
BICK “↓” to FCK “↑” (Note 24)	tBFCK	0.4 x tBCK	-	-	ns
BICK “↑” to SDTO (BCKP bit = “0”)	tBSD	-	-	80	ns
BICK “↓” to SDTO (BCKP bit = “1”)	tBSD	-	-	80	ns
SDTI Hold Time	tSDH	50	-	-	ns
SDTI Setup Time	tSDS	50	-	-	ns
Except DSP Mode: (Figure 14)					
FCK Edge to BICK “↑” (Note 21)	tFCKB	50	-	-	ns
BICK “↑” to FCK Edge (Note 21)	tBFCK	50	-	-	ns
FCK to SDTO (MSB) (Except I ² S mode)	tFSD	-	-	80	ns
BICK “↓” to SDTO	tBSD	-	-	80	ns
SDTI Hold Time	tSDH	50	-	-	ns
SDTI Setup Time	tSDS	50	-	-	ns
EXT Slave Mode (Figure 13)					
MCKI Frequency: 256fs	fCLK	1.8816	2.048	12.288	MHz
512fs	fCLK	3.7632	4.096	13.312	MHz
1024fs	fCLK	7.5264	8.192	13.312	MHz
Pulse Width Low	tCLKL	0.4/fCLK	-	-	ns
Pulse Width High	tCLKH	0.4/fCLK	-	-	ns
FCK Frequency (MCKI = 256fs)	fFCK	7.35	8	48	kHz
(MCKI = 512fs)	fFCK	7.35	8	26	kHz
(MCKI = 1024fs)	fFCK	7.35	8	13	kHz
Duty Cycle	duty	45	-	55	%
BICK Period	tBCK	312.5	-	-	ns
BICK Pulse Width Low	tBCKL	130	-	-	ns
Pulse Width High	tBCKH	130	-	-	ns
Audio Interface Timing (Figure 14)					
FCK Edge to BICK “↑” (Note 21)	tFCKB	50	-	-	ns
BICK “↑” to FCK Edge (Note 21)	tBFCK	50	-	-	ns
FCK to SDTO (MSB) (Except I ² S mode)	tFSD	-	-	80	ns
BICK “↓” to SDTO	tBSD	-	-	80	ns
SDTI Hold Time	tSDH	50	-	-	ns
SDTI Setup Time	tSDS	50	-	-	ns

Parameter	Symbol	min	typ	max	Units
EXT Master Mode (Figure 4)					
MCKI Frequency: 256fs	fCLK	1.8816	2.048	12.288	MHz
512fs	fCLK	3.7632	4.096	13.312	MHz
1024fs	fCLK	7.5264	8.192	13.312	MHz
Pulse Width Low	tCLKL	0.4/fCLK	-	-	ns
Pulse Width High	tCLKH	0.4/fCLK	-	-	ns
FCK Frequency (MCKI = 256fs)	fFCK	7.35	8	48	kHz
(MCKI = 512fs)	fFCK	7.35	8	26	kHz
(MCKI = 1024fs)	fFCK	7.35	8	13	kHz
Duty Cycle	dFCK	-	50	-	%
BICK: Period (BCKO1-0 bit = "00")	tBCK	-	1/16fFCK	-	ns
(BCKO1-0 bit = "01")	tBCK	-	1/32fFCK	-	ns
(BCKO1-0 bit = "10")	tBCK	-	1/64fFCK	-	ns
Duty Cycle	dBCK	-	50	-	%
Audio Interface Timing					
DSP Mode: (Figure 5, Figure 6)					
FCK "↑" to BICK "↑" (Note 23)	tDBF	0.5 x tBCK-40	0.5 x tBCK	0.5 x tBCK+40	ns
FCK "↑" to BICK "↓" (Note 24)	tDBF	0.5 x tBCK-40	0.5 x tBCK	0.5 x tBCK+40	ns
BICK "↑" to SDTO (BCKP bit = "0")	tBSD	-70	-	70	ns
BICK "↓" to SDTO (BCKP bit = "1")	tBSD	-70	-	70	ns
SDTI Hold Time	tSDH	50	-	-	ns
SDTI Setup Time	tSDS	50	-	-	ns
Except DSP Mode: (Figure 7)					
BICK "↓" to FCK Edge	tBFCK	-40	-	40	ns
FCK to SDTO (MSB) (Except I ² S mode)	tFSD	-70	-	70	ns
BICK "↓" to SDTO	tBSD	-70	-	70	ns
SDTI Hold Time	tSDH	50	-	-	ns
SDTI Setup Time	tSDS	50	-	-	ns

Note 21. BICK rising edge must not occur at the same time as FCK edge.

Note 22. Duty Cycle = (the width of "L")/(the period of clock)*100

Note 23. MSBS, BCKP bits = "00" or "11"

Note 24. MSBS, BCKP bits = "01" or "10"

Parameter	Symbol	min	typ	max	Units
Control Interface Timing (3-wire Serial mode)					
CCLK Period	tCCK	200	-	-	ns
CCLK Pulse Width Low	tCCKL	80	-	-	ns
Pulse Width High	tCCKH	80	-	-	ns
CDTI Setup Time	tCDS	40	-	-	ns
CDTI Hold Time	tCDH	40	-	-	ns
CSN "H" Time	tCSW	150	-	-	ns
CSN edge to CCLK "↑" (Note 26)	tCSS	50	-	-	ns
CCLK "↑" to CSN edge (Note 26)	tCSH	50	-	-	ns
CCLK "↓" to CDTI (at Read Command)	tDCD	-	-	70	ns
CSN "↑" to CDTI (Hi-Z) (at Read Command) (Note 27)	tCCZ	-	-	70	ns
Control Interface Timing (I²C Bus mode):					
SCL Clock Frequency	fSCL	-	-	400	kHz
Bus Free Time Between Transmissions	tBUF	1.3	-	-	μs
Start Condition Hold Time (prior to first clock pulse)	tHD:STA	0.6	-	-	μs
Clock Low Time	tLOW	1.3	-	-	μs
Clock High Time	tHIGH	0.6	-	-	μs
Setup Time for Repeated Start Condition	tSU:STA	0.6	-	-	μs
SDA Hold Time from SCL Falling (Note 28)	tHD:DAT	0	-	-	μs
SDA Setup Time from SCL Rising	tSU:DAT	0.1	-	-	μs
Rise Time of Both SDA and SCL Lines	tR	-	-	0.3	μs
Fall Time of Both SDA and SCL Lines	tF	-	-	0.3	μs
Setup Time for Stop Condition	tSU:STO	0.6	-	-	μs
Capacitive Load on Bus	C _b	-	-	400	pF
Pulse Width of Spike Noise Suppressed by Input Filter	tSP	0	-	50	ns
Reset Timing					
PDN Pulse Width (Note 29)	tPD	150	-	-	ns
PMADC "↑" to SDTO valid (Note 30)					
ADRST bit = "0"	tPDV	-	1059	-	1/fs
ADRST bit = "1"	tPDV	-	291	-	1/fs
Digital MIC Interface					
DMCLK Output Timing ; C_L=100pF					
Period	tSCK	-	1/(64fs)	-	ns
Rise Time	tSRise	-	-	10	ns
Fall Time	tSFall	-	-	10	ns
Duty Cycle	dSCK	40	50	60	%
DMDAT Interface Timing					
DMDAT Setup Time	tSDS	50	-	-	ns
DMDAT Hold Time	tSDH	0	-	-	ns

Note 25. I²C-bus is a trademark of NXP B.V.

Note 26. CCLK rising edge must not occur at the same time as CSN edge.

Note 27. R_L = 1kΩ/10% change (Pull-up to DVDD)

Note 28. Data must be held long enough to bridge the 300ns-transition time of SCL.

Note 29. The AK4636 can be reset by the PDN pin = "L"

Note 30. This is the count of FCK "↑" from the PMADC = "1".

■ Timing Diagram

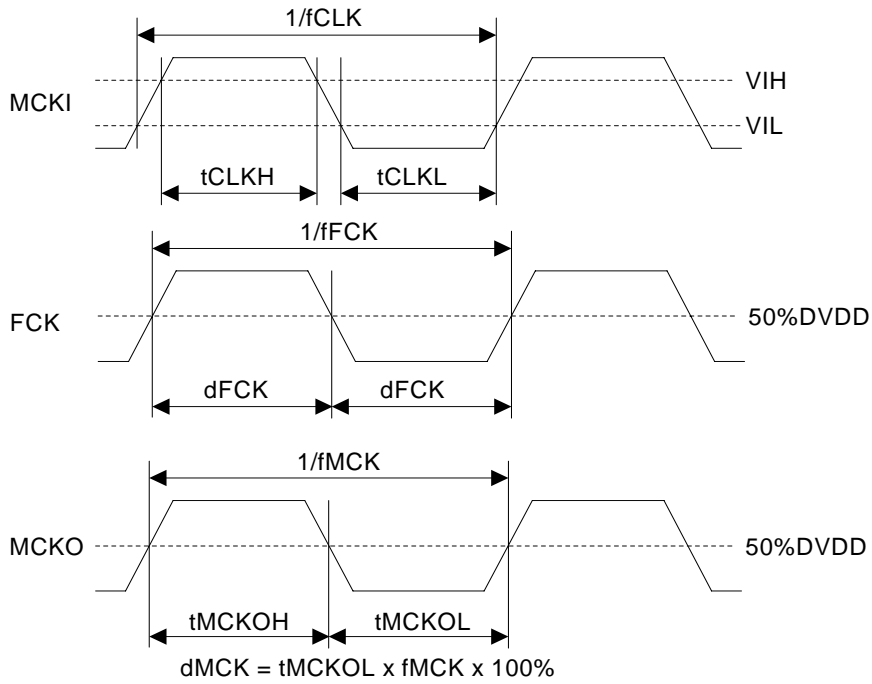

Figure 4. Clock Timing (PLL/EXT Master mode) (MCKO isn't available at EXT Master Mode)

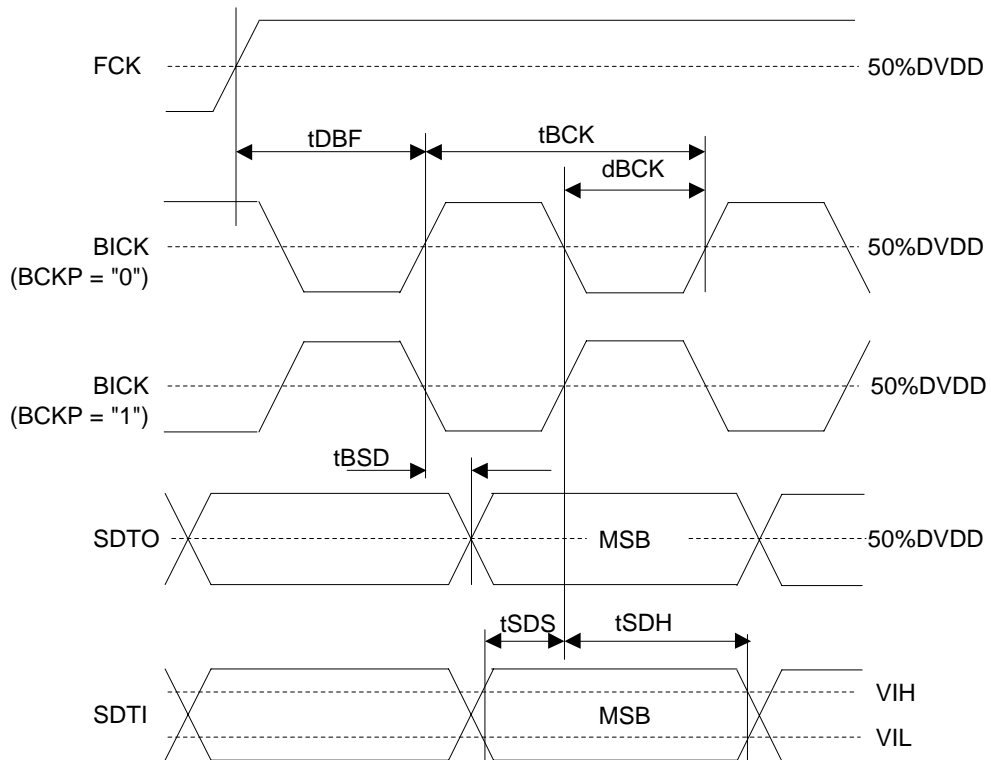

Figure 5. Audio Interface Timing (PLL/EXT Master mode & DSP mode: MSBS = "0")

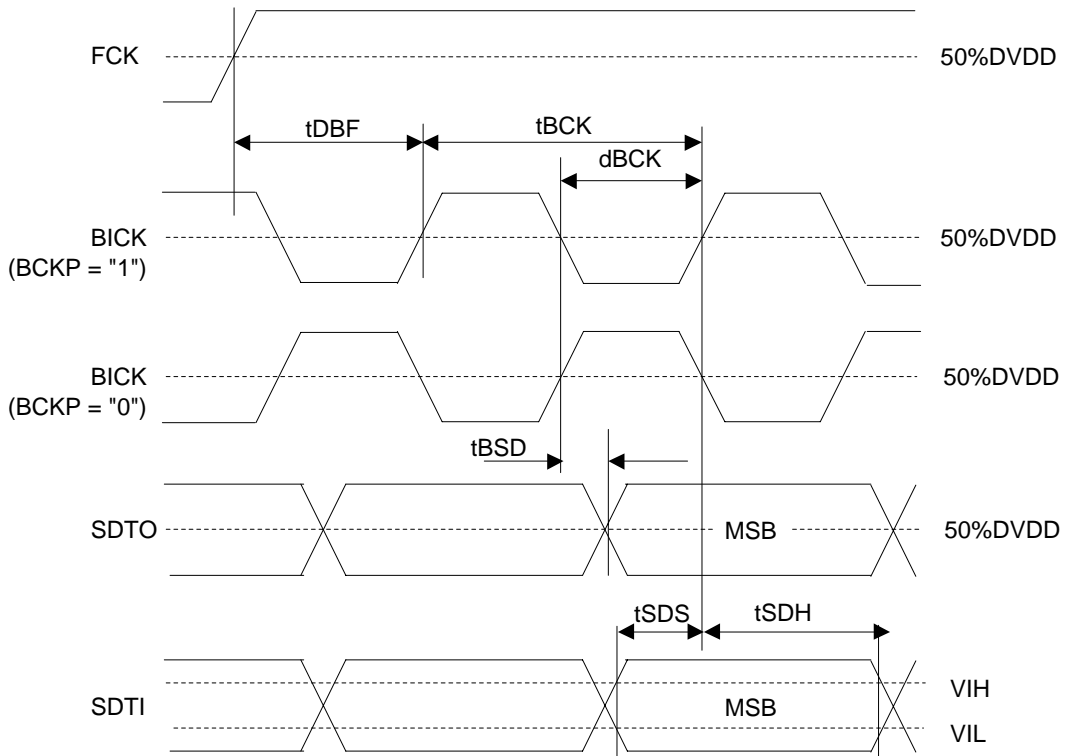

Figure 6. Audio Interface Timing (PLL/EXT Master mode & DSP mode: MSBS = "1")

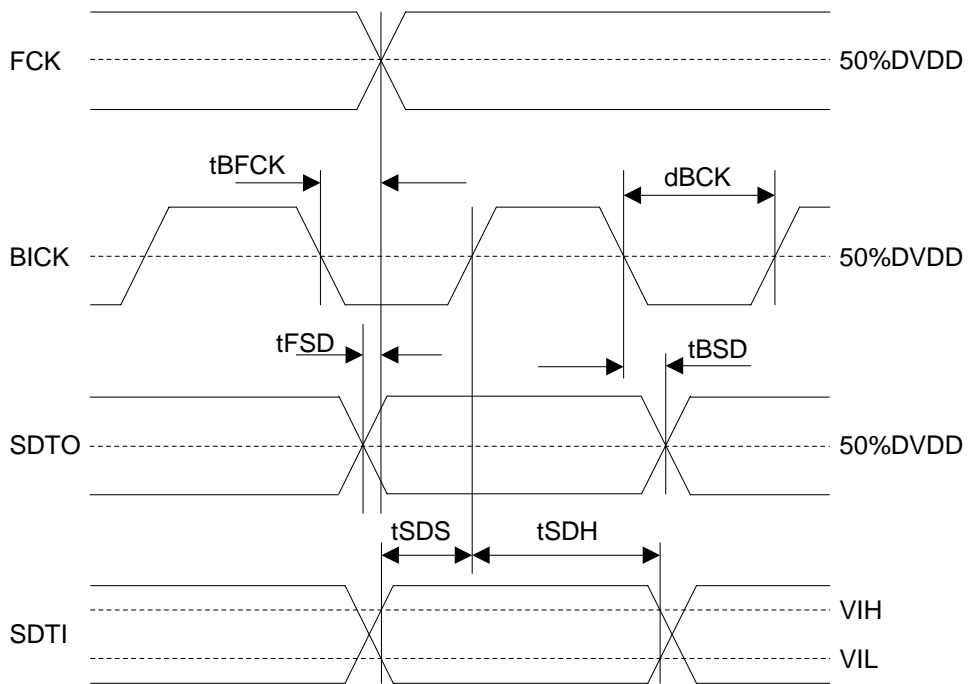

Figure 7. Audio Interface Timing (PLL/EXT Master mode & Except DSP mode)

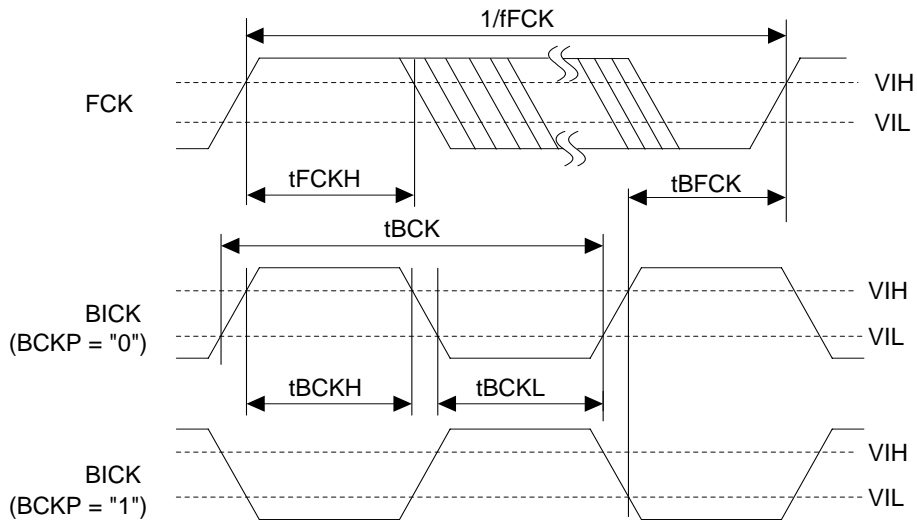

Figure 8. Clock Timing (PLL Slave mode; PLL Reference Clock = FCK or BICK pin & DSP mode; MSBS = 0)

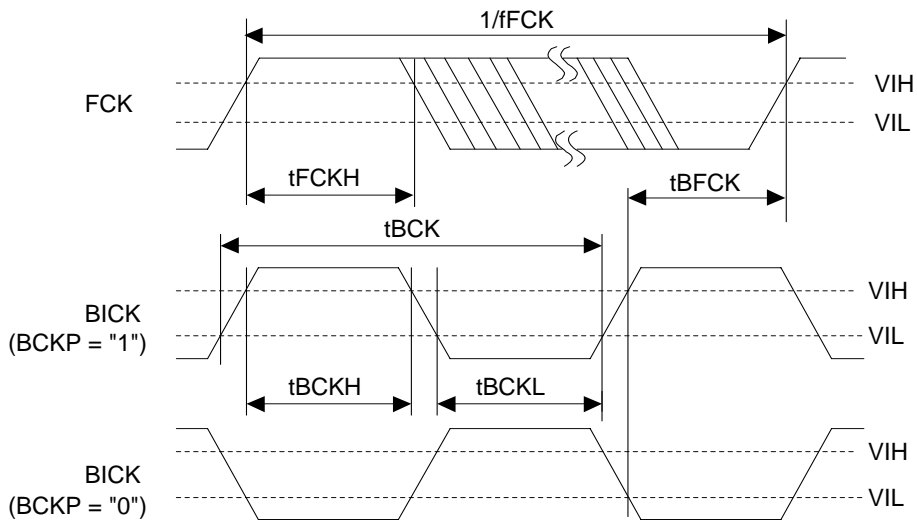

Figure 9. Clock Timing (PLL Slave mode; PLL Reference Clock = FCK or BICK pin & DSP mode; MSBS = 1)

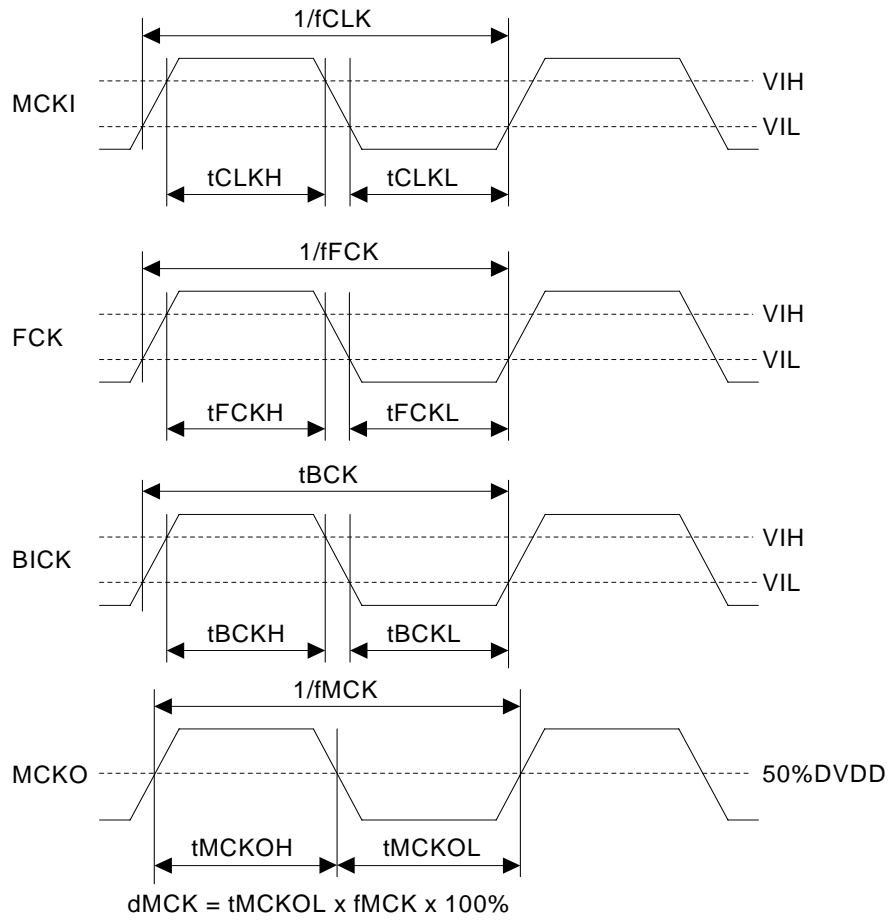

Figure 10. Clock Timing (PLL Slave mode; PLL Reference Clock = MCKI pin & Except DSP mode)

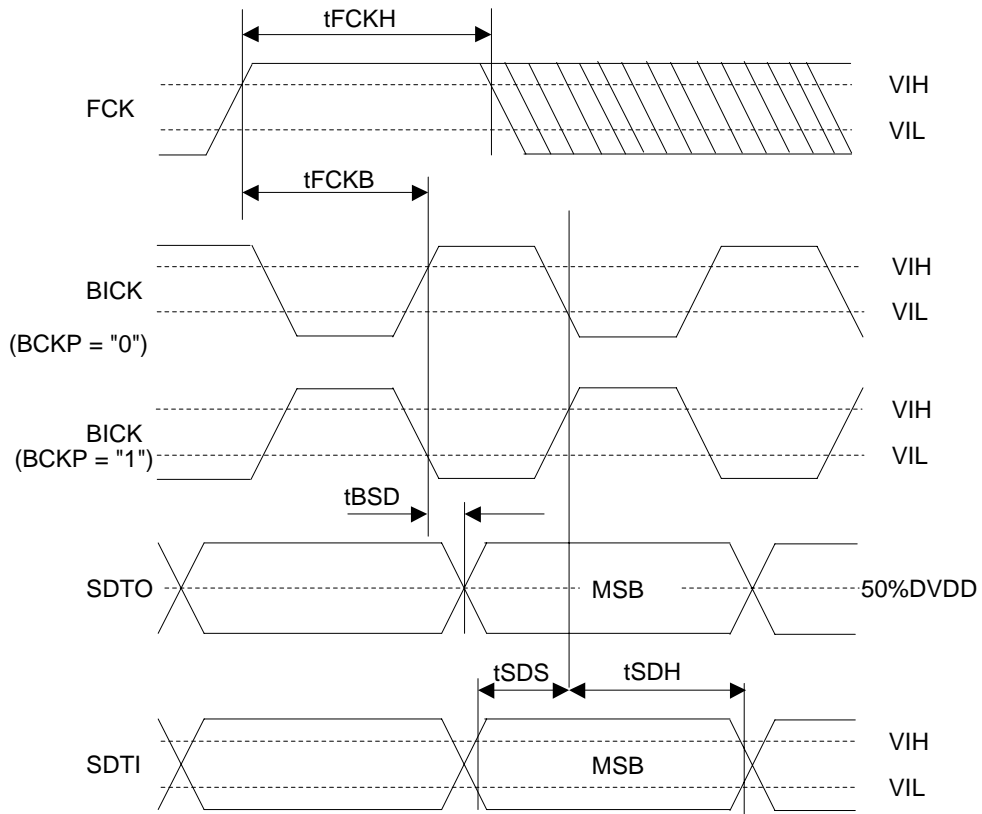

Figure 11. Audio Interface Timing (PLL Slave mode & DSP mode; MSBS = 0)

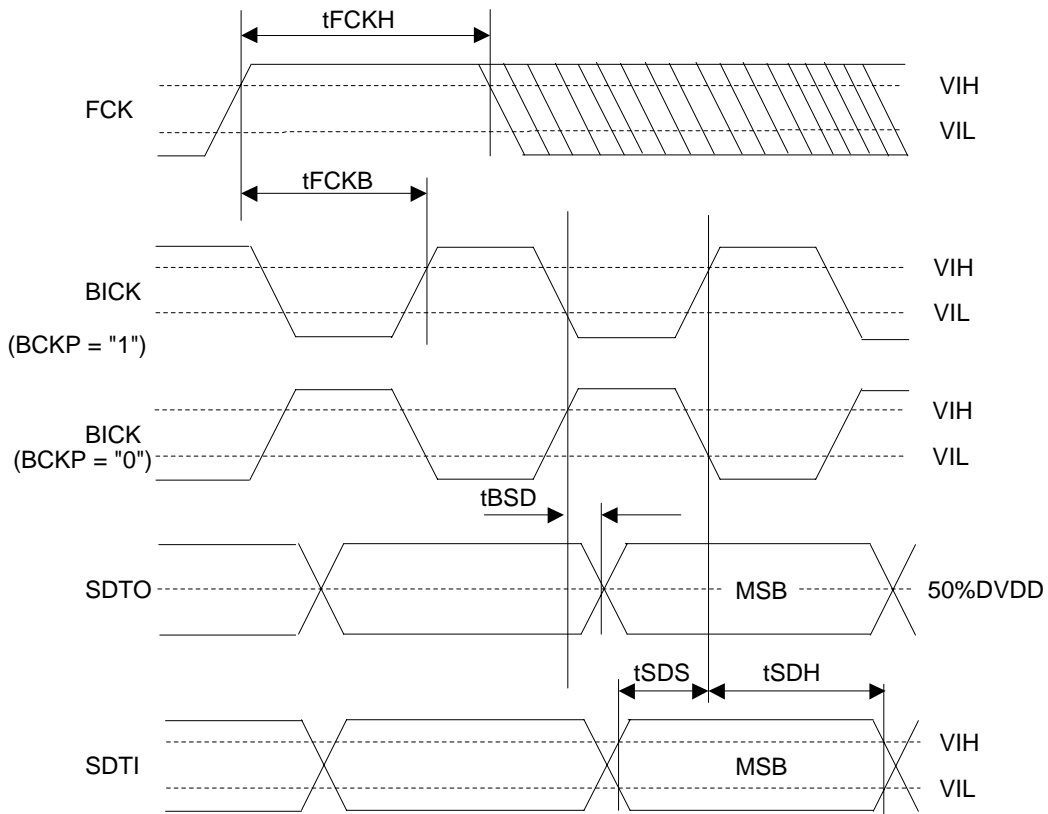
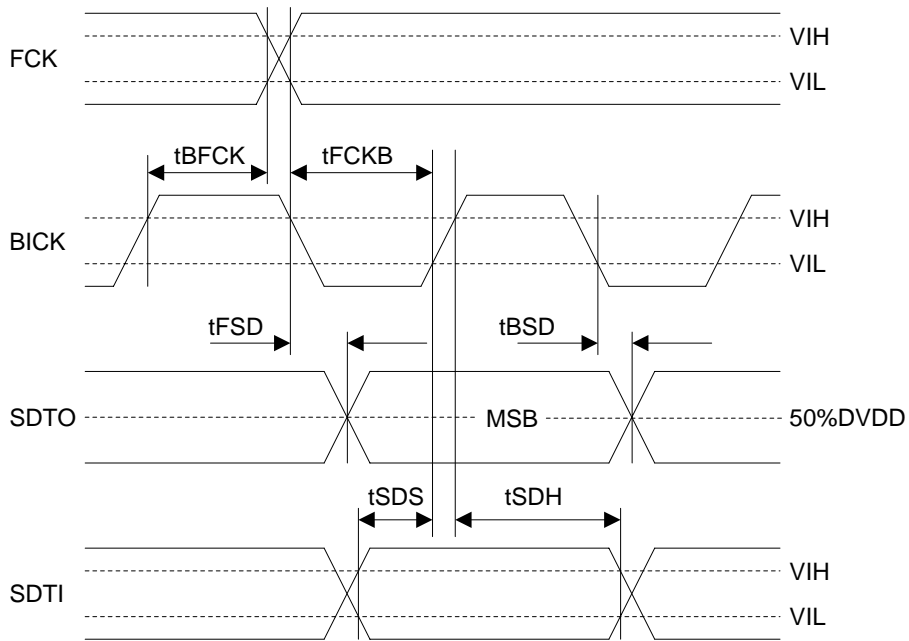
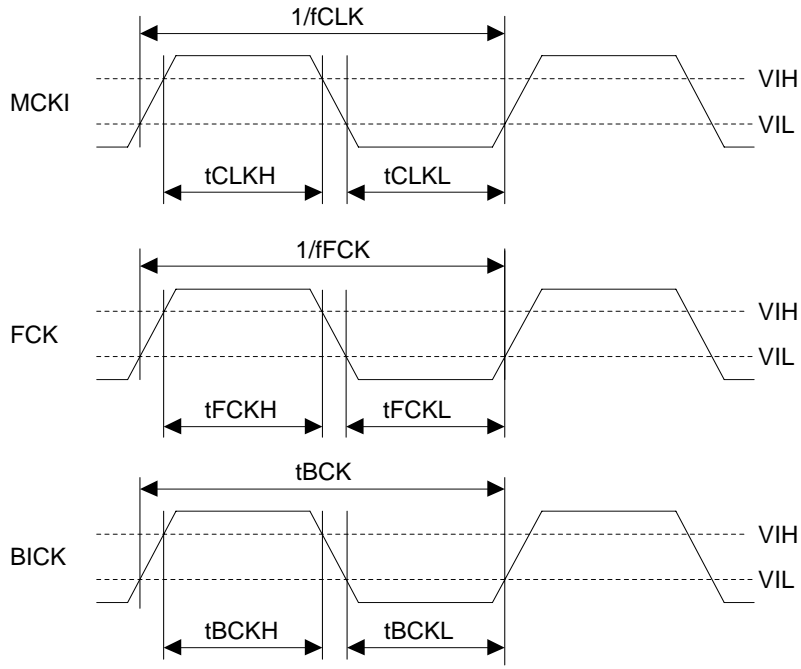

Figure 12. Audio Interface Timing (PLL Slave mode, DSP mode; MSBS = 1)



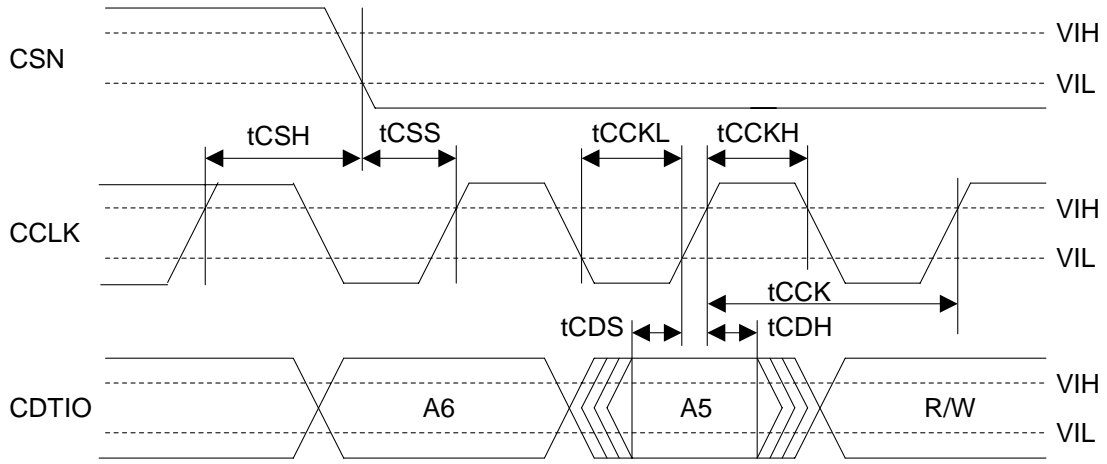

Figure 15. WRITE Command Input Timing

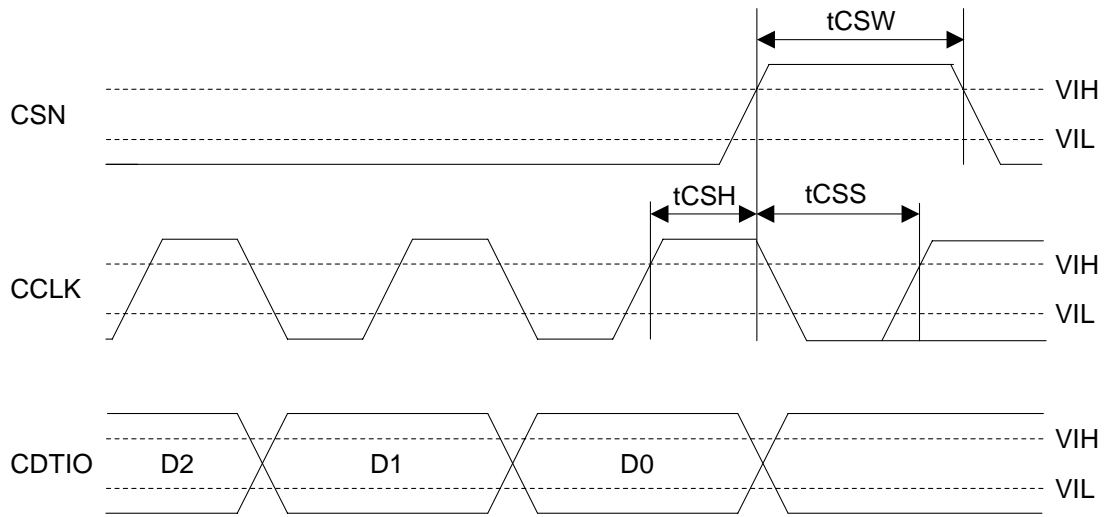

Figure 16. WRITE Data Input Timing

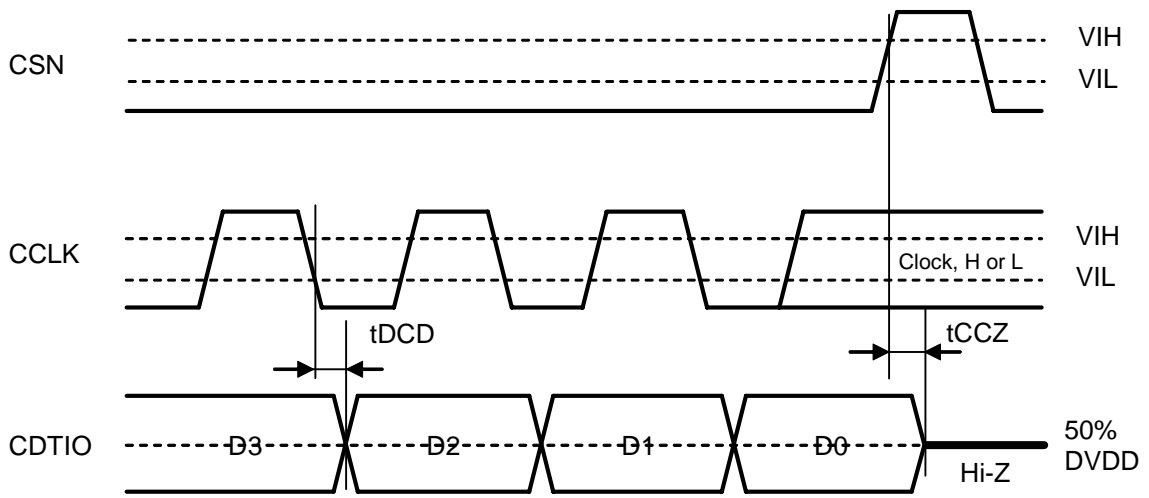

Figure 17. Read Data Output Timing

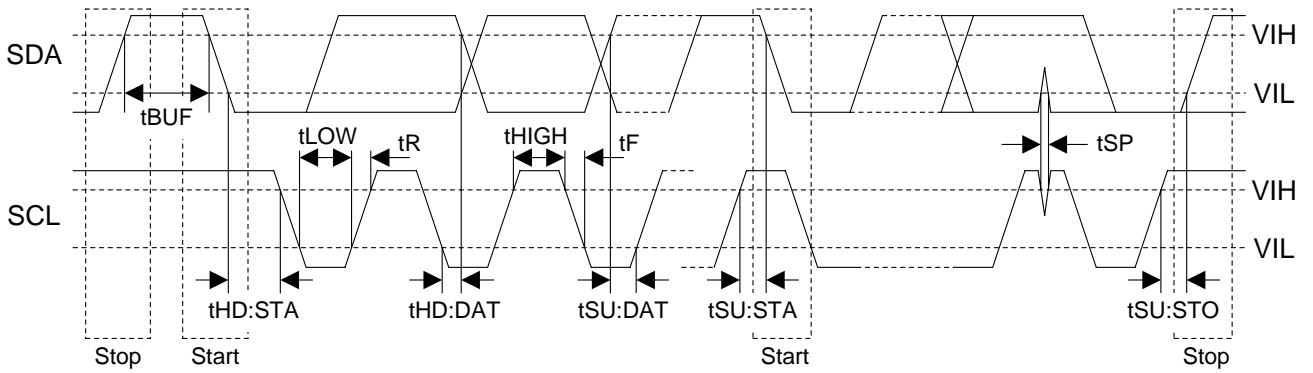

Figure 18. I²C Bus Mode Timing

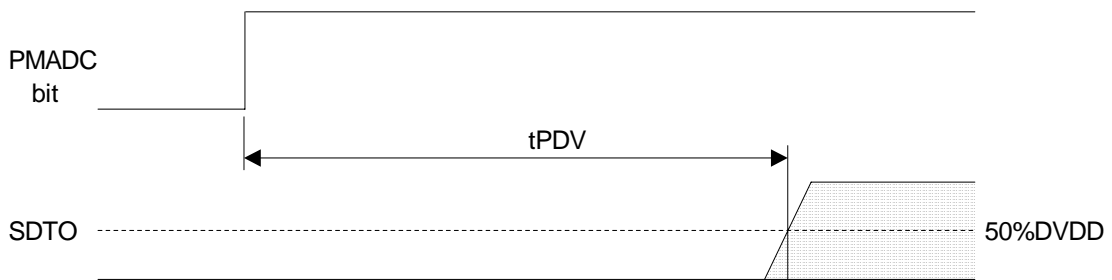

Figure 19. Power Down & Reset Timing 1

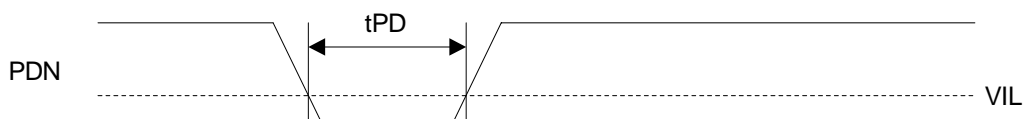

Figure 20. Power Down & Reset Timing 2

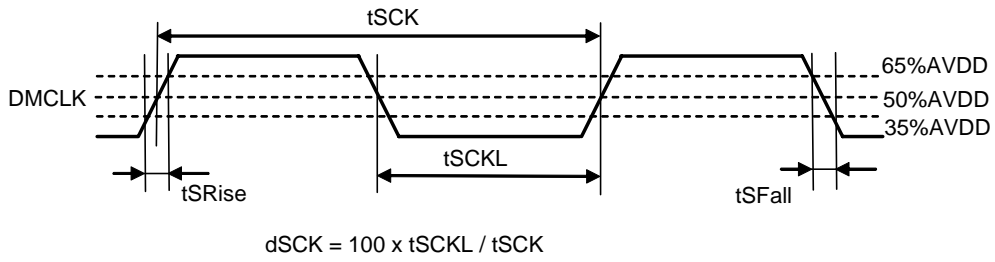

Figure 21. DMCLK Clock Timing

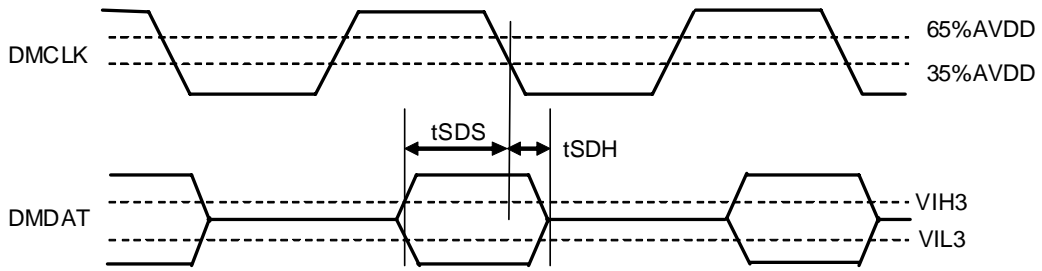

Figure 22. Audio Interface Timing (DCLKP bit = "1")

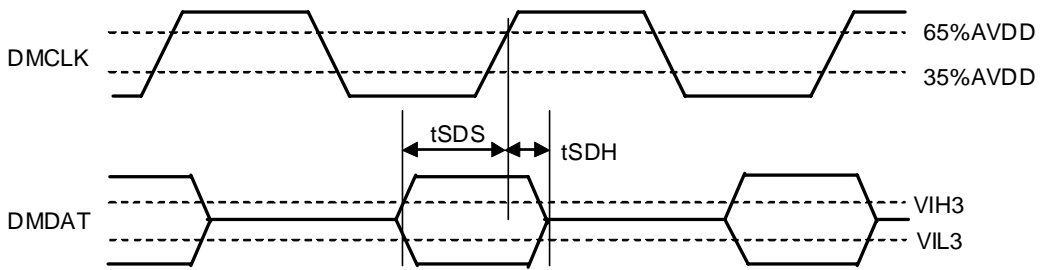

Figure 23. Audio Interface Timing (DCLKP bit = "0")

OPERATION OVERVIEW

■ System Clock

There are the following five clock modes to interface with external devices. (Table 1 and Table 2)

Mode	PMPLL bit	M/S bit	PLL3-0 bit	Figure
PLL Master Mode	1	1	Table 4	Figure 24
PLL Slave Mode 1 (PLL Reference Clock: MCKI pin)	1	0	Table 4	Figure 25
PLL Slave Mode 2 (PLL Reference Clock: FCK or BICK pin)	1	0	Table 4	Figure 26 Figure 27
EXT Slave Mode	0	0	x	Figure 28
EXT Master Mode	0	1	x	Figure 29

Table 1. Clock Mode Setting (x: Don't care)

Mode	MCKO bit	MCKO pin	MCKI pin	BICK pin	FCK pin
PLL Master Mode	0	“L” Output	Master Clock Input for PLL (Note 31)	16fs/32fs/64fs Output	1fs Output
	1	256fs Output			
PLL Slave Mode 1 (PLL Reference Clock: MCKI pin)	0	“L” Output	Master Clock Input for PLL (Note 31)	≥ 16fs Input	1fs Input
	1	256fs Output			
PLL Slave Mode 2 (PLL Reference Clock: FCK or BICK pin)	0	“L” Output	GND	16fs/32fs/64fs Input	1fs Input
EXT Slave Mode	0	“L” Output	256fs/ 512fs/ 1024fs Input	≥ 32fs Input	1fs Input
EXT Master Mode	0	“L” Output	256fs/ 512fs/ 1024fs Input	32fs/64fs Output	1fs Output

Note 31. 11.2896MHz/12MHz/13.5MHz/24MHz/27MHz

Table 2. Clock pins state in Clock Mode

■ Master Mode/Slave Mode

The M/S bit selects either master or slave modes. M/S bit = “1” selects master mode and “0” selects slave mode. When the AK4636 is power-down mode (PDN pin = “L”) and when exits reset state, the AK4636 is in slave mode. After exiting reset state, the AK4636 changes to master mode by bringing M/S bit = “1”.

When the AK4636 is in master mode, FCK and BICK pins are a floating state until M/S bit becomes “1”. The FCK and BICK pins of the AK4636 should be pulled-down or pulled-up by about 100kΩ resistor externally to avoid the floating state.

M/S bit	Mode
0	Slave Mode
1	Master Mode

(default)

Table 3. Select Master/Slave Mod

■ PLL Mode

When PMPLL bit is “1”, a fully integrated analog phase locked loop (PLL) generates a clock that is selected by the PLL3-0 and FS3-0 bits. The PLL lock time is shown in Table 4. Either when the AK4636 is supplied stable clocks after PLL is powered-up (PMPLL bit = “0” → “1”) or when the sampling frequency changes, the PLL lock time is the same.

1) Setting of PLL Mode

Mode	PLL3 bit	PLL2 bit	PLL1 bit	PLL0 bit	PLL Reference Clock Input Pin	Input Frequency	R and C of VCOC pin (Note 32)		PLL Lock Time (max)
							R[Ω]	C[F]	
0	0	0	0	0	FCK pin	1fs	6.8k	220n	160ms
1	0	0	0	1	BICK pin	16fs	10k	4.7n	2ms
2	0	0	1	0	BICK pin	32fs	10k	4.7n	2ms
3	0	0	1	1	BICK pin	64fs	10k	4.7n	2ms
4	0	1	0	0	MCKI pin	11.2896MHz	10k	4.7n	10ms
6	0	1	1	0	MCKI pin	12MHz	10k	4.7n	10ms
7	0	1	1	1	MCKI pin	24MHz	10k	4.7n	10ms
12	1	1	0	0	MCKI pin	13.5MHz	10k	10n	10ms
13	1	1	0	1	MCKI pin	27MHz	10k	10n	10ms
Others	Others				N/A				

(default)

Note 32. The tolerance of R is ±5%, the tolerance of C is ±30%

Table 4. Setting of PLL Mode (*fs: Sampling Frequency, N/A: Not available)

2) Setting of sampling frequency in PLL Mode.

When PLL2 bit is “1” (PLL reference clock input is the MCKI pin), the sampling frequency is selected by FS3-0 bits as defined in Table 5.

Mode	FS3 bit	FS2 bit	FS1 bit	FS0 bit	Sampling Frequency
0	0	0	0	0	8kHz
1	0	0	0	1	12kHz
2	0	0	1	0	16kHz
3	0	0	1	1	24kHz
4	0	1	0	0	7.35kHz
5	0	1	0	1	11.025kHz
6	0	1	1	0	14.7kHz
7	0	1	1	1	22.05kHz
10	1	0	1	0	32kHz
11	1	0	1	1	48kHz
14	1	1	1	0	29.4kHz
15	1	1	1	1	44.1kHz
Others	Others				N/A

(default)

Table 5. Setting of Sampling Frequency at PLL2 bit = “1” and PMPLL bit = “1” (N/A: Not available)

When PLL2 bit is “0” (PLL reference clock input is FCK or BICK pin), the sampling frequency is selected by FS3-2 bits. (Table 6)

Mode	FS3 bit	FS2 bit	FS1 bit	FS0 bit	Sampling Frequency Range
0	0	0	x	x	7.35kHz ≤ fs ≤ 12kHz
1	0	1	x	x	12kHz < fs ≤ 24kHz
2	1	0	x	x	24kHz < fs ≤ 48kHz
Others	Others				N/A

(default)

(x: Don't care, N/A: Not available)

Table 6. Setting of Sampling Frequency at PLL2 bit = “0” and PMPLL bit = “1”

■ PLL Unlock State

1) PLL Master Mode (PMPLL bit = “1”, M/S bit = “1”)

In this mode, after PMPLL bit = “0” → “1” until the PLL is locked, the BICK and FCK pins output “L” for a moment, and invalid frequency clock is output from the MCKO pin at MCKO bit = “1”. If the MCKO bit is “0”, the MCKO pin outputs “L”. (Table 7)

When sampling frequency is changed, BICK and FCK pins do not output irregular frequency clocks but go to “L” by setting PMPLL bit to “0”.

PLL State	MCKO pin		BICK pin	FCK pin
	MCKO bit = “0”	MCKO bit = “1”		
After that PMPLL bit “0” → “1”	“L” Output	Invalid	“L” Output	“L” Output
PLL Unlock	“L” Output	Invalid	Invalid	Invalid
PLL Lock	“L” Output	256fs Output	See Table 9	1fs Output

Table 7. Clock Operation at PLL Master Mode (PMPLL bit = “1”, M/S bit = “1”)

2) PLL Slave Mode (PMPLL bit = “1”, M/S bit = “0”)

In this mode, an invalid clock is output from the MCKO pin after PMPLL bit = “0” → “1” or sampling frequency is changed. 256fs is output from the MCKO pin when PLL is locked again. ADC and DAC output invalid data when the PLL is unlocked. For DAC, the output signal should be muted by writing “0” to DACA and DACS bits in Addr=02H.

PLL State	MCKO pin	
	MCKO bit = “0”	MCKO bit = “1”
After that PMPLL bit “0” → “1”	“L” Output	Invalid
PLL Unlock	“L” Output	Invalid
PLL Lock	“L” Output	Output

Table 8. Clock Operation at PLL Slave Mode (PMPLL bit = “1”, M/S bit = “0”)

■ PLL Master Mode (PMPLL bit = “1”, M/S bit = “1”)

When an external clock (11.2896MHz, 12MHz, 13.5MHz, 24MHz or 27MHz) is input to the MCKI pin, the MCKO, BICK and FCK clocks are generated by an internal PLL circuit. The MCKO output frequency is fixed to 256fs, the output is enabled by MCKO bit. The BICK is selected among 16fs, 32fs or 64fs, by BCKO1-0 bits. (Table 9)

In DSP mode, FCK output can select Duty 50% or High-output only during 1 BICK cycle (Table 10). Except DSP mode, FCKO bit should be set “0”.

When BICK output frequency is 16fs, the audio interface format supports Mode 0 only (DSP Mode).

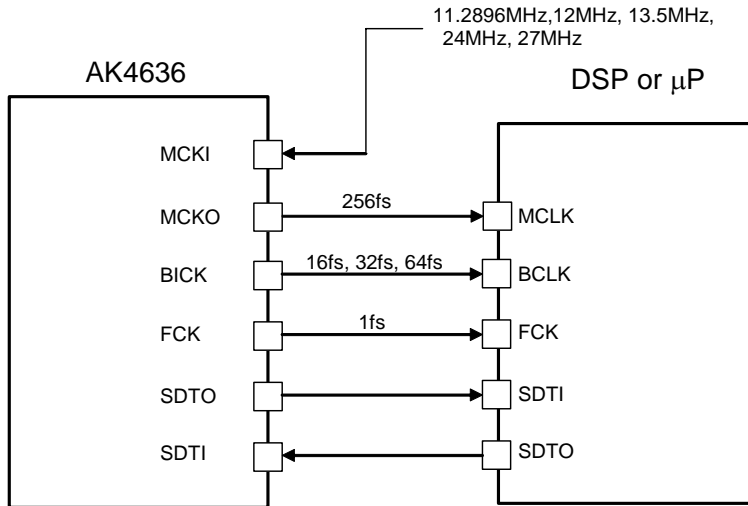

Figure 24. PLL Master Mode

Mode	BCKO1	BCKO0	BICK Output Frequency
0	0	0	16fs
1	0	1	32fs
2	1	0	64fs
3	1	1	N/A

(default)

Table 9. BICK Output Frequency at Master Mode

Mode	FCKO	FCK Output
0	0	Duty = 50%
1	1	High Width = 1/fBCK

(default)

fBCK is BICK Output Frequency.

Table 10. FCK Output at PLL Master Mode and DSP Mode

■ PLL Slave Mode (PMPLL bit = “1”, M/S bit = “0”)

A reference clock of PLL is selected among the input clocks to the MCKI, BICK or FCK pin. The required clock to the AK4636 is generated by an internal PLL circuit. Input frequency is selected by PLL3-0 bits. When BICK input frequency is 16fs, the audio interface format supports Mode 0 only (DSP Mode).

a) PLL reference clock: MCKI pin

BICK and FCK inputs should be synchronized with MCKO output. The phase between MCKO and FCK is not important. The MCKO pin outputs the frequency selected by FS3-0 bits (Note 5)

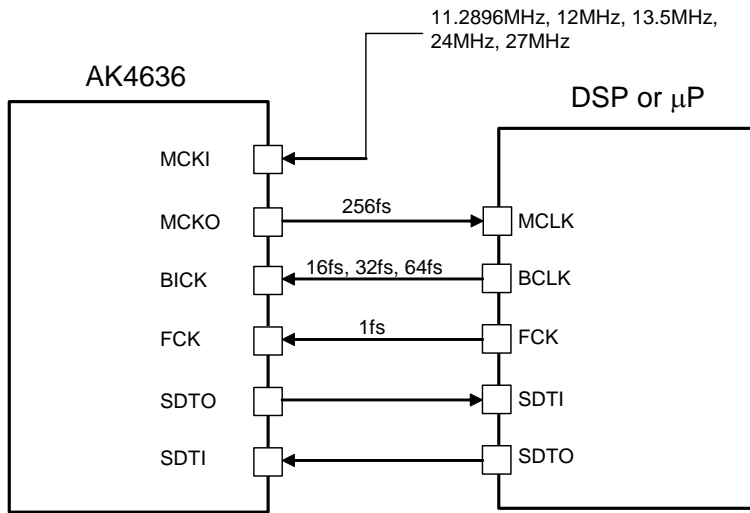

Figure 25. PLL Slave Mode 1 (PLL Reference Clock: MCKI pin)

b) PLL reference clock: BICK or LRCK pin

The sampling frequency corresponds to a range from 7.35kHz to 48kHz by changing FS3-0 bits. (Table 6)

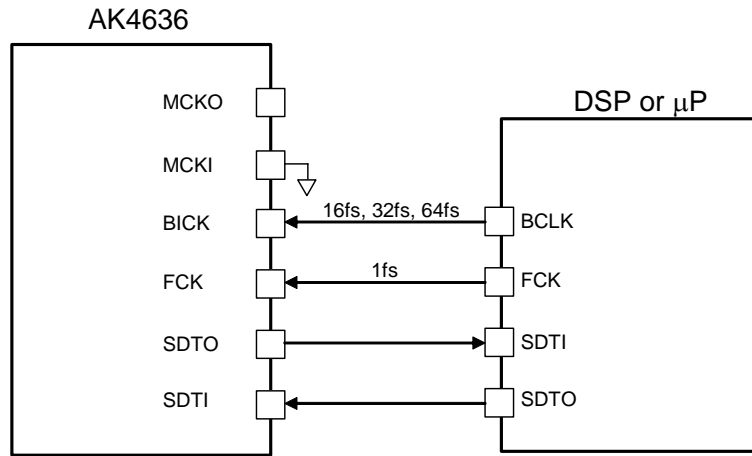

Figure 26 PLL Slave Mode 2 (PLL Reference Clock: BICK pin)

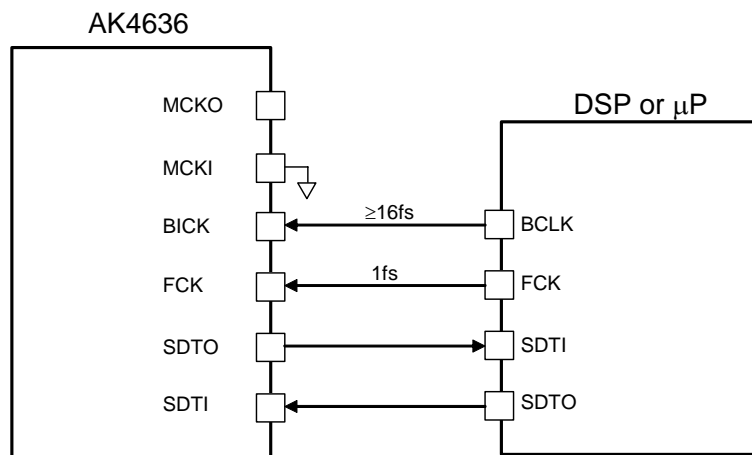

Figure 27. PLL Slave Mode 2 (PLL Reference Clock: FCK pin)

The external clocks (MCKI, BICK and FCK) should always be present whenever the ADC or DAC or Programmable Filter is in operation (PMADC bit = “1”, PMDM bit = “1”, PMDAC bit = “1” or PMPFIL bit = “1”). If these clocks are not provided, the AK4636 may draw excess current and it is not possible to operate properly because utilizes dynamic refreshed logic internally. If the external clocks are not present, the ADC, DAC and Programmable Filter should be in the power-down mode (PMADC bit = PMDM bit = PMDAC bit = PMPFIL bit = “0”).

■ EXT Slave Mode (PMPLL bit = “0”, M/S bit = “0”)

When PMPLL bit is “0”, the AK4636 becomes EXT Slave mode. Master clock is input from the MCKI pin, the internal PLL circuit is not operated. This mode is compatible with I/F of the normal audio CODEC. The clocks required to operate are MCKI (256fs, 512fs or 1024fs), FCK (fs) and BICK ($\geq 32fs$). The master clock (MCKI) should be synchronized with FCK. The phase between these clocks is not important. The input frequency of MCKI is selected by FS1-0 bits. (Table 11)

Mode	FS3-2 bits	FS1 bit	FS0 bit	MCKI Input Frequency	Sampling Frequency Range	
0	x	0	0	256fs	$7.35kHz \leq fs \leq 48kHz$	(default)
1	x	0	1	1024fs	$7.35kHz \leq fs \leq 13kHz$	
2	x	1	0	512fs	$7.35kHz \leq fs \leq 26kHz$	
3	x	1	1	256fs	$7.35kHz \leq fs \leq 48kHz$	

Table 11. MCKI Frequency at EXT Slave Mode (PMPLL bit = “0”, M/S bit = “0”) (x: Don’t care)

External Slave Mode does not support Mode 0 (DSP Mode) of Audio Interface Format.

The S/N of the DAC at low sampling frequencies is worse than at high sampling frequencies due to out-of-band noise. The out-of-band noise can be reduced by using higher frequency master clock. (Table 12, Table 13)

MCKI	S/N (fs = 8kHz, 20kHzLPF + A-weighted)
	DAC → AOUT
256fs	81dB
512fs	89dB
1024fs	89dB

Table 12. Relationship between MCKI and S/N of AOUT and SPK-Amp

MCKI	Output Noise Level (SVDD = 3.3V, fs = 8kHz, 20kHzLPF + A-weighted)
	SDTI → SPK-Amp
256fs	- 61dBV
512fs	- 75dBV
1024fs	- 83dBV

Table 13. Relationship between MCKI and Output Noise Level of SPK-Amp

The external clocks (MCKI, BICK and FCK) should always be present whenever the ADC or DAC or Programmable Filter is in operation (PMADC bit = “1”, PMDM bit = “1”, PMDAC bit = “1” or PMPFIL bit = “1”). If these clocks are not provided, the AK4636 may draw excess current and it is not possible to operate properly because utilizes dynamic refreshed logic internally. If the external clocks are not present, the ADC, DAC, SPK and Programmable Filter should be in the power-down mode (PMADC bit = PMDM bit = PMDAC bit = PMPFIL bit = “0”).

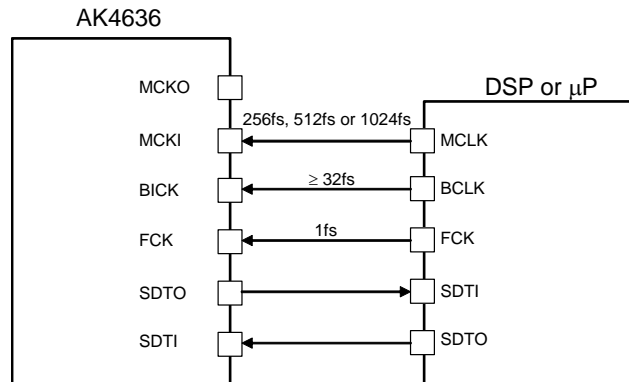

Figure 28. EXT Slave Mode

■ EXT Master Mode (PMPLL bit = “0”, M/S bit = “1”)

The AK4636 becomes EXT Master Mode by setting PMPLL bit = “0” and M/S bit = “1”. Master clock is input from the MCKI pin, the internal PLL circuit is not operated. The clock required to operate is MCKI (256fs, 512fs or 1024fs). The input frequency of MCKI is selected by FS1-0 bits (Table 14). The BICK is selected among 32fs or 64fs, by BCKO1-0 bits (Table 15). FCK bit should be set to “0”.

Mode	FS3-2 bits	FS1 bit	FS0 bit	MCKI Input Frequency	Sampling Frequency Range	
0	x	0	0	256fs	$7.35\text{kHz} \leq fs \leq 48\text{kHz}$	(default)
1	x	0	1	1024fs	$7.35\text{kHz} \leq fs \leq 13\text{kHz}$	
2	x	1	0	512fs	$7.35\text{kHz} \leq fs \leq 26\text{kHz}$	
3	x	1	1	256fs	$7.35\text{kHz} \leq fs \leq 48\text{kHz}$	

Table 14. MCKI Frequency at EXT Master Mode (PMPLL bit = “0”, M/S bit = “1”) (x: Don’t care)

External Master Mode does not support Mode 0 (DSP Mode) of Audio Interface Format.

MCKI should always be present whenever the ADC, DAC or Programmable Filter is in operation (PMADC bit = “1”, PMDM bit = “1”, PMDAC bit = “1” or PMPFIL bit = “1”). If MCKI is not provided, the AK4636 may draw excess current and it is not possible to operate properly because utilizes dynamic refreshed logic internally. If MCKI is not present, the ADC, DAC and Programmable Filter should be in the power-down mode (PMADC bit = PMDM bit = PMDAC bit = PMPFIL bit = “0”).

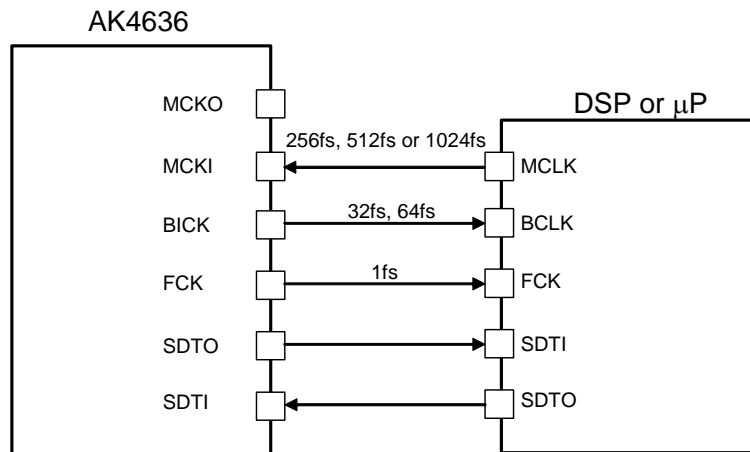

Figure 29. EXT Master Mode

Mode	BCKO1	BCKO0	BICK Output Frequency	
0	0	0	N/A	
1	0	1	32fs	(default)
2	1	0	64fs	
3	1	1	N/A	

Table 15. BICK Output Frequency at Master Mode (N/A: Not available)

■ Audio Interface Format

Four types of data formats are available and are selected by setting the DIF1-0 bits. (Table 16) In all modes, the serial data is MSB first, 2's complement format. Audio interface formats can be used in both master and slave modes. FCK and BICK pins are outputs in master mode, but must be inputs in slave mode.

In Mode 1-3, the SDTO is clocked out on the falling edge of BICK and the SDTI is latched on the rising edge.

Mode	DIF1	DIF0	SDTO (ADC)	SDTI (DAC)	BICK	Figure
0	0	0	DSP Mode	DSP Mode	$\geq 16fs$	Table 17
1	0	1	MSB justified	LSB justified	$\geq 32fs$	Figure 30
2	1	0	MSB justified	MSB justified	$\geq 32fs$	Figure 31 (default)
3	1	1	I ² S compatible	I ² S compatible	$\geq 32fs$	Figure 32

Table 16. Audio Interface Format

In Mode0 (DSP mode), the audio I/F timing is changed by BCKP and MSBS bits.

When BCKP bit is “0”, SDTO data is output on a rising edge of BICK, SDTI data is latched on a falling edge of BICK. When BCKP bit is “1”, SDTO data is output on a falling edge of BICK, SDTI data is latched on a rising edge of BICK.

MSB data position of SDTO and SDTI can be shifted for a half period of BICK by MSBS bit.

MSBS bit	BCKP bit	Audio Interface Format
0	0	Figure 33 (default)
0	1	Figure 34
1	0	Figure 35
1	1	Figure 36

Table 17. Audio Interface Format in Mode 0

If 16-bit data, the output of ADC, is converted to 8-bit data by removing LSB 8-bit, “-1” at 16bit data is converted to “-1” at 8-bit data. And when the DAC playbacks this 8-bit data, “-1” at 8-bit data will be converted to “-256” at 16-bit data and this is a large offset. This offset can be removed by adding the offset of “128” to 16-bit data before converting to 8-bit data.

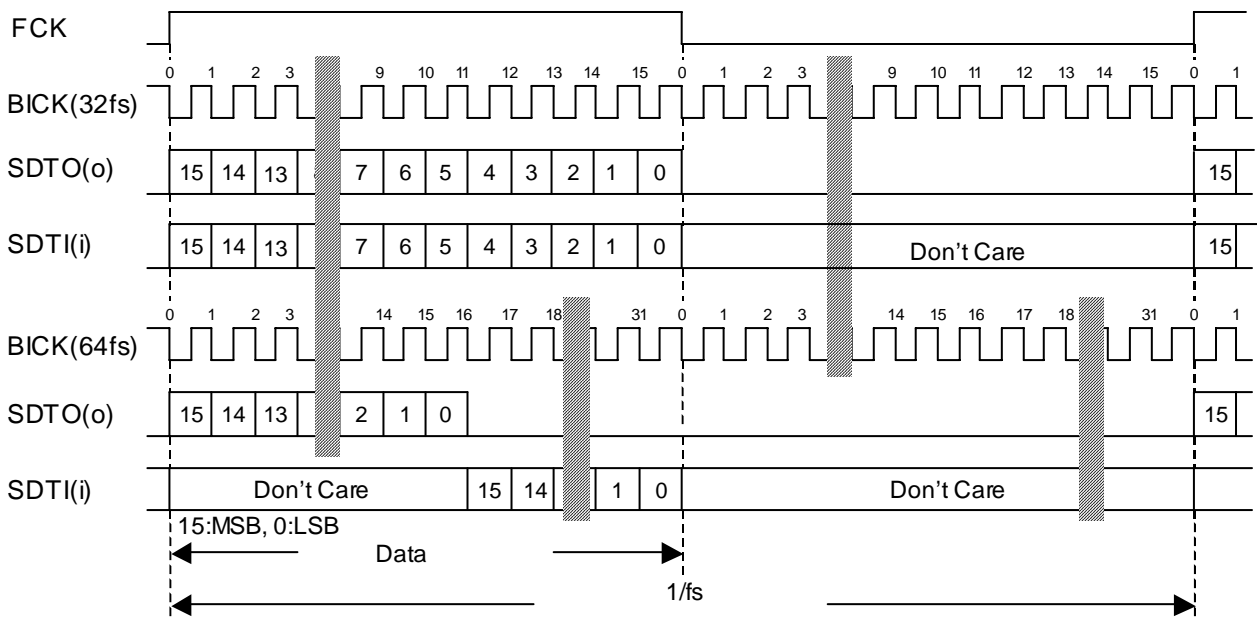

Figure 30. Mode 1 Timing

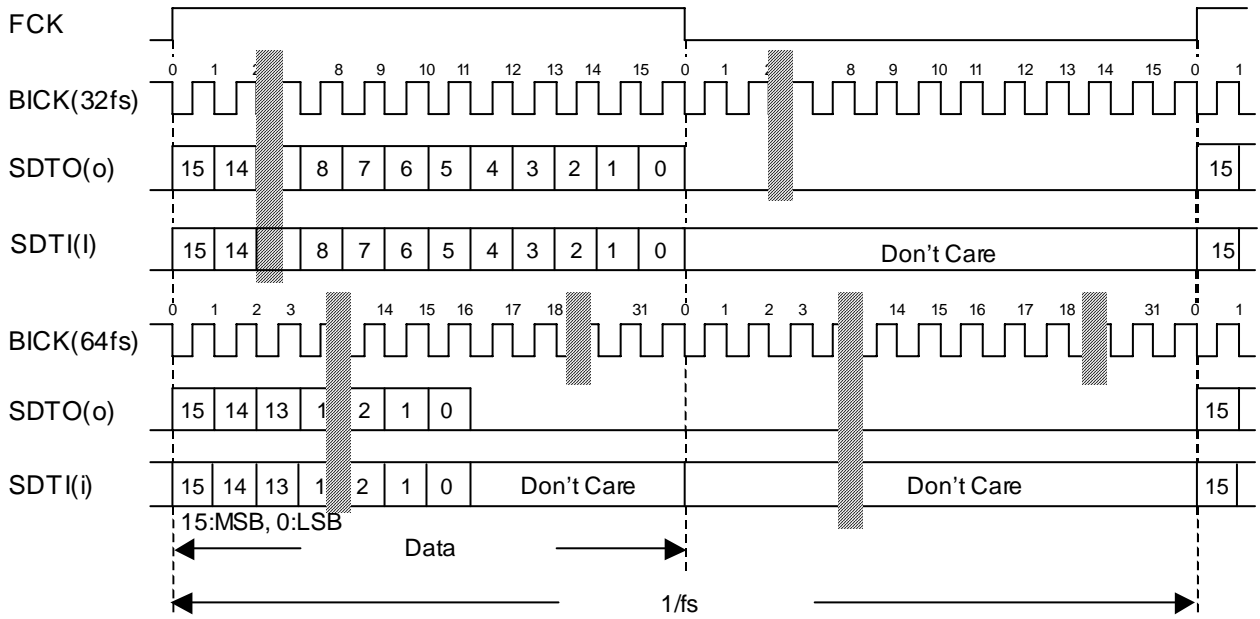

Figure 31. Mode 2 Timing

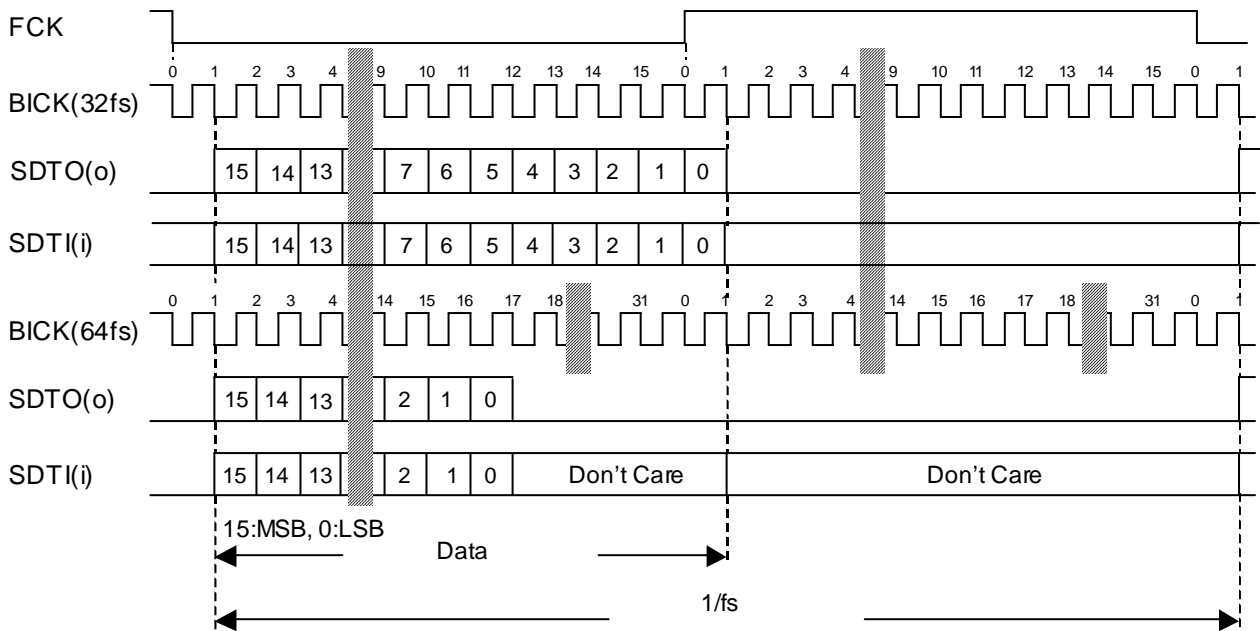

Figure 32. Mode 3 Timing

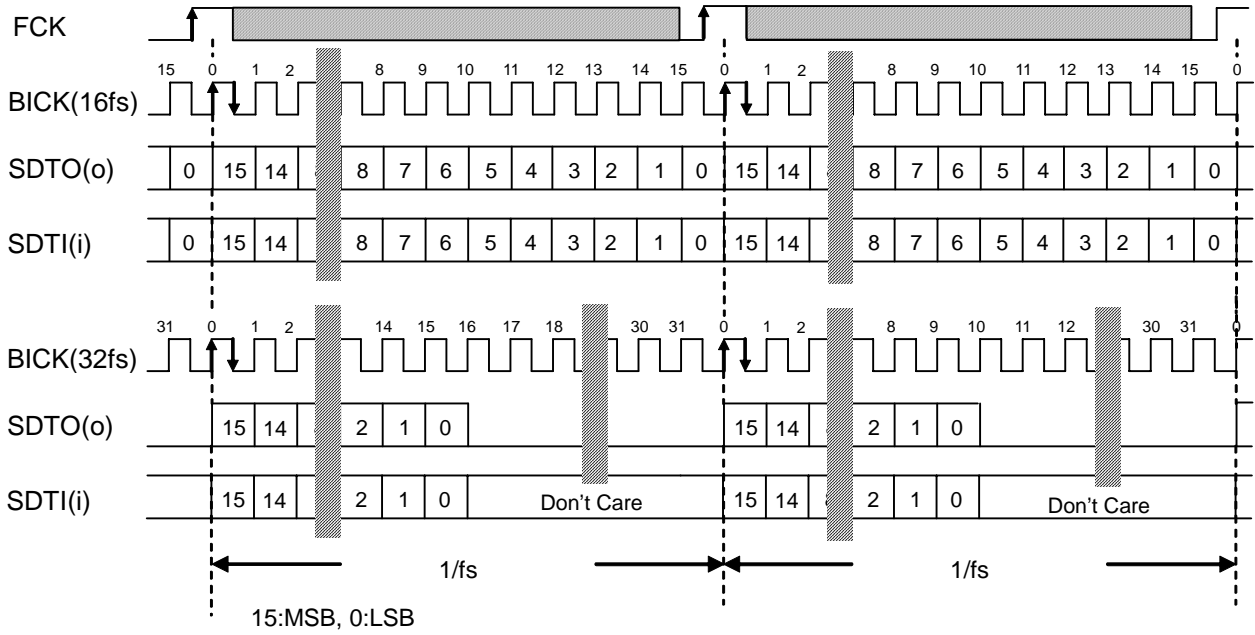

Figure 33. Mode 0 Timing (BCKP = "0", MSBS = "0")

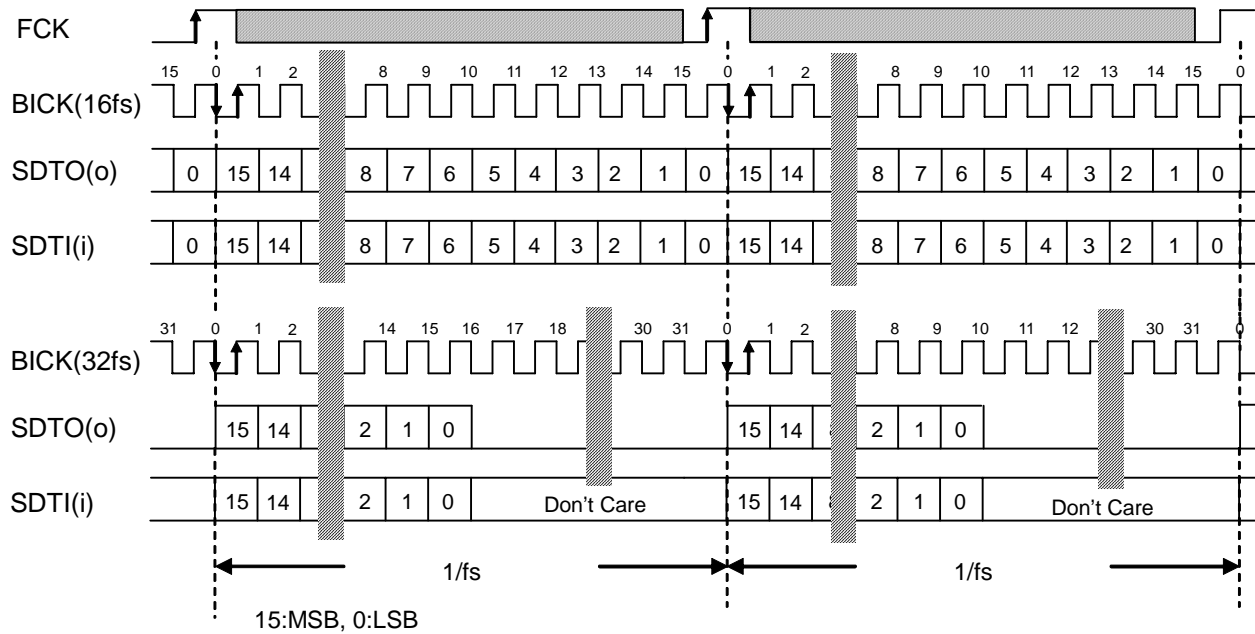

Figure 34. Mode 0 Timing (BCKP = "1", MSBS = "0")

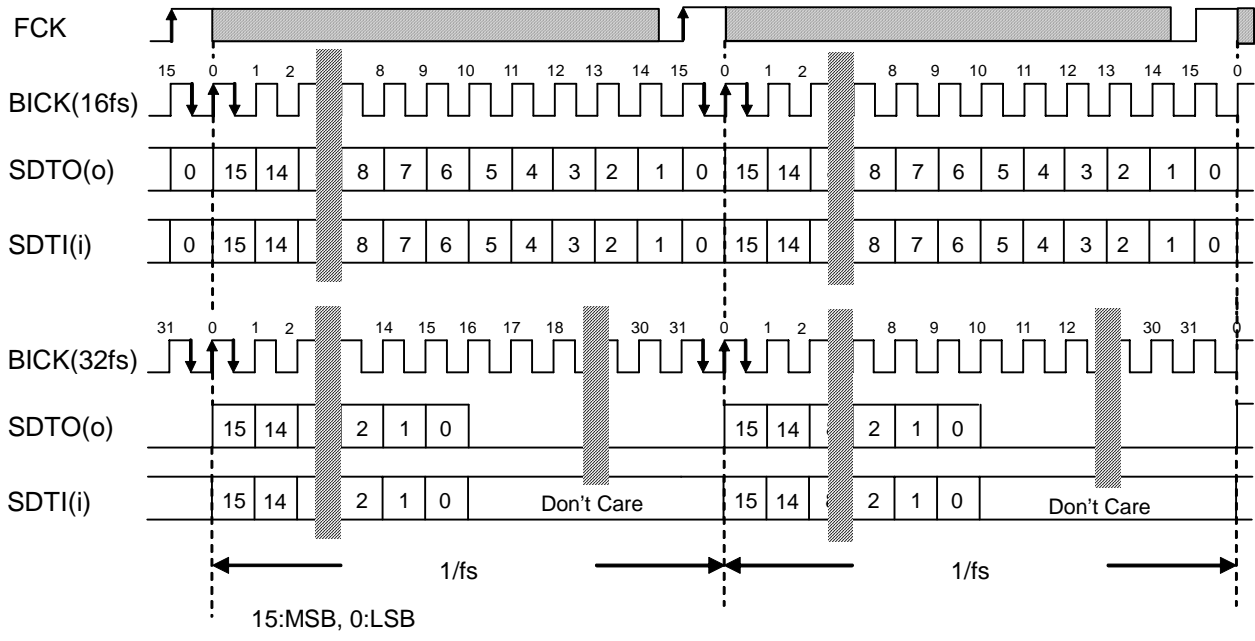

Figure 35. Mode 0 Timing (BCKP = "0", MSBS = "1")

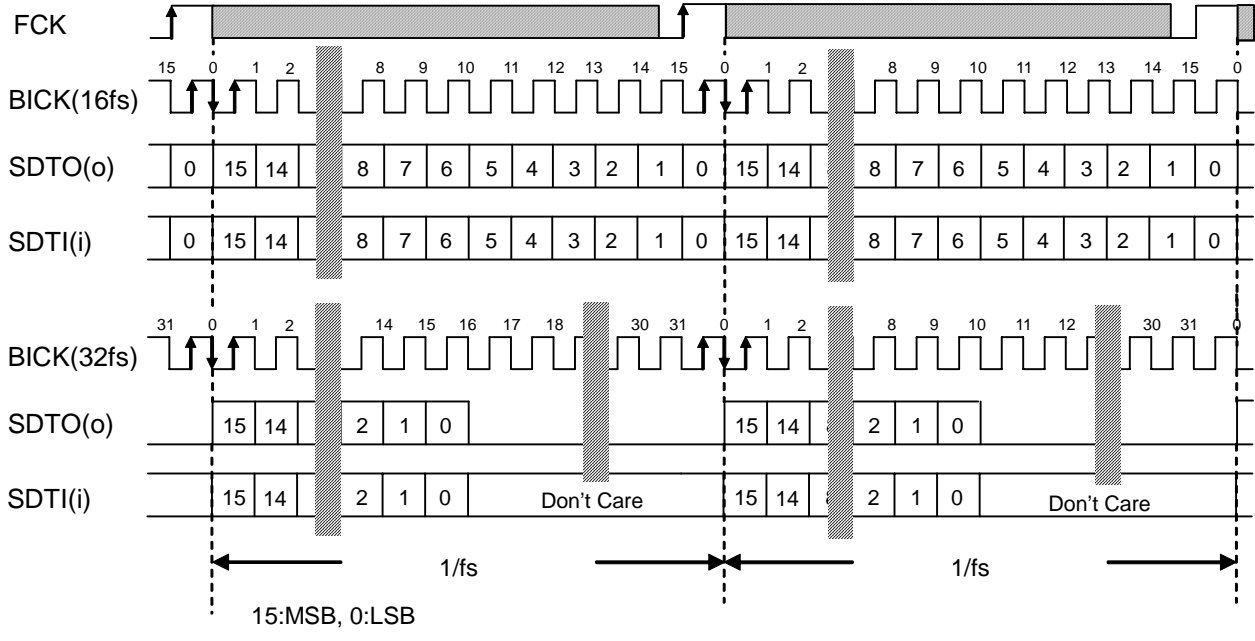

Figure 36. Mode 0 Timing (BCKP = "1", MSBS = "1")

■ System Reset

When power-up, the PDN pin should be “L” and change to “H” after all powers are supplied. “L” time of 150ns or more is needed to reset the AK4636.

The ADC enters an initialization cycle when the PMADC bit is changed from “0” to “1”. The initialization cycle time is set by ADRST bit (Table 18). During the initialization cycle, the ADC digital data outputs of both channels are forced to a 2's compliment, “0”. The ADC output reflects the analog input signal after the initialization cycle is complete. The same initializing cycle is occurred when using the digital microphone. The DAC does not require an initialization cycle.

(Note) Off-set occurs in the initial data depending on the conditions of a microphone and cut-off frequency of HPF.

When Off-set becomes a problem, lengthen initialization time of ADC by ADRST bit = “0” or do not use initial output data of ADC.

ADRST bit	Init Cycle			
	Cycle	fs = 8kHz	fs = 16kHz	fs = 48kHz
0	1059/fs	132.4ms	66.2ms	22.1ms
1	291/fs	36.4ms	18.2ms	6.1ms

Table 18 Initialization cycle of ADC

■ MIC/LINE/Digital MIC Selector

The AK4636 has an input selector. When MDIF bit is “0”, LIN bit selects the MIC pin or LIN pin. When MDIF bit is “1”, MIC/LIN pins become MICP/MICN pins, and full-differential input is available. When DMIC bit is “1”, MIC/LIN pins become DMCLC/ DMDAT pins, and they can be connected to digital microphone.

MDIF bit	LIN bit	DMIC bit	Input circuit	Input pin
0	0	0	Single-Ended	MIC pin
0	1	0	Single-Ended	LIN pin
1	x	0	Differential	MICP/MICN pin
x	x	1	Digital MIC	DMDAT/ DMCLK pin

(default)

Table 19. Input Select (x: Don't care)

■ MIC Gain Amplifier

The AK4636 has a Gain Amplifier for Microphone input. These gains are selected by the MGAIN3-0 bit. The typical input impedance is 30kΩ.

MGAIN3 bit	MGAIN2 bit	MGAIN1 bit	MGAIN0 bit	Input Gain
0	0	0	0	0dB
0	0	0	1	+20dB
0	0	1	0	+26dB
0	0	1	1	+32dB
0	1	0	0	+10dB
0	1	0	1	+17dB
0	1	1	0	+23dB
0	1	1	1	+29dB
1	0	0	0	+3dB
1	0	0	1	+6dB
Others				N/A

(default)

Table 20. Input Gain (N/A: Not available)

■ MIC Power (DMPE bit = “0”)

The MPI pin supplies power for the Microphone. This output voltage is 2.3V (typ) and the load resistance is minimum 2kΩ. Any capacitor must not be connected to the MPI pin directly.

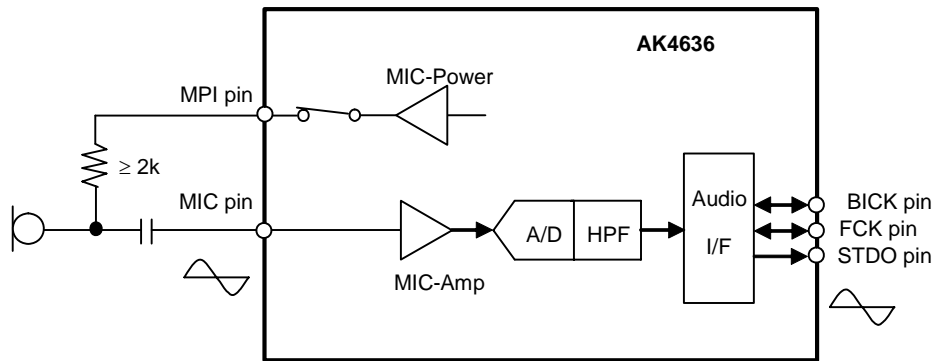

Figure 37. MIC Block Circuit

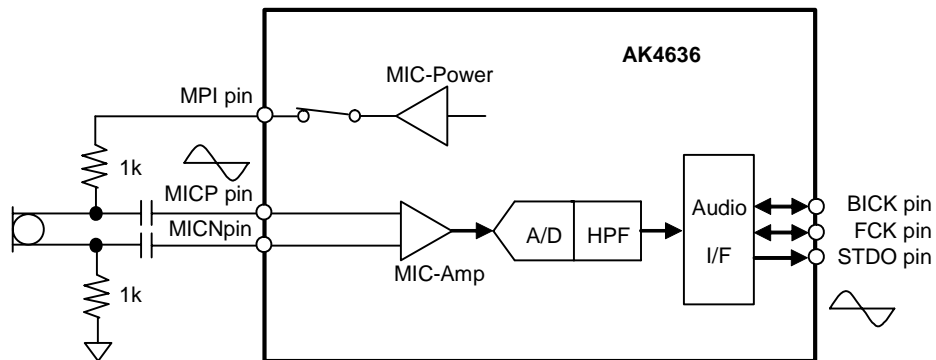

Figure 38. MIC Block Circuit (Differential; MDIF = “1”)

■ Digital MIC

1. Connection to Digital MIC

The AK4636 can be connected to digital microphone by setting DMIC bit = "1". When DMIC bit is set to "1", the MPI, LIN and MIC pins become DMP (digital microphone power supply), DMCLK (digital microphone clock supply) and DMDAT (digital microphone data input) pins respectively. By setting DMPE bit = "1", the DMP (digital microphone power supply) pin and can supply the power to the digital microphone (max. 2mA). When DMPE bit = "0", the same power supply as AVDD must be provided to the digital microphone. The Figure 39 and Figure 40 show connection examples. The DMCLK signal is output from the AK4636, and the digital microphone outputs 1bit data, which is generated by $\Delta\Sigma$ Modulator, from DMDAT. PMDML/R bits control power up/down of the digital block (Decimation Filter and Digital Filter). PMADL/PMADR bits settings do not affect the digital microphone power management. The DCLKE bit controls ON/OFF of the clock output from the DMCLK pin. When the AK4636 is powered down (PDN pin="L"), the DMCLK and DMDAT pin are floating state. Pull-down resistors must be connected to the DMCLK and DMDAT pin externally to avoid floating state.

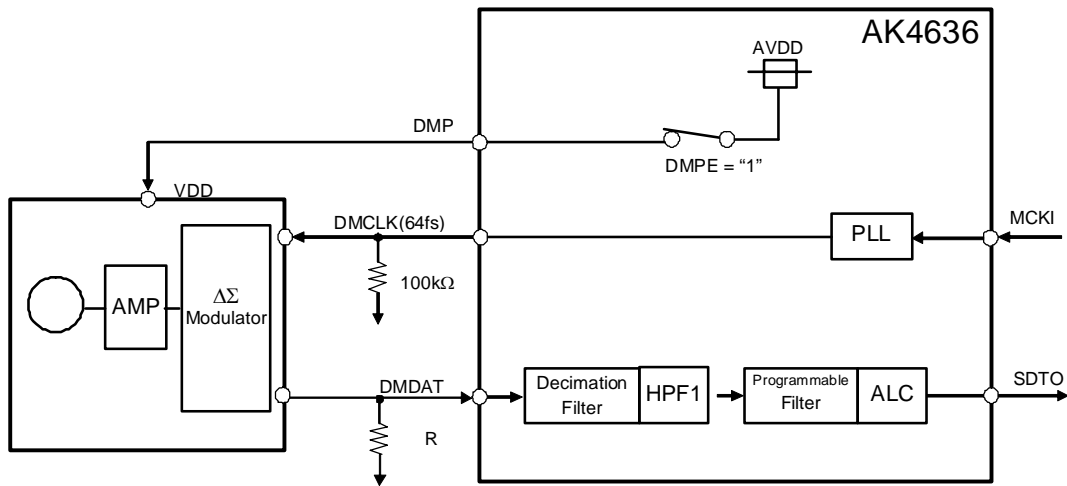

Figure 39. Connection Example of Digital MIC (DMPE bit = "1")

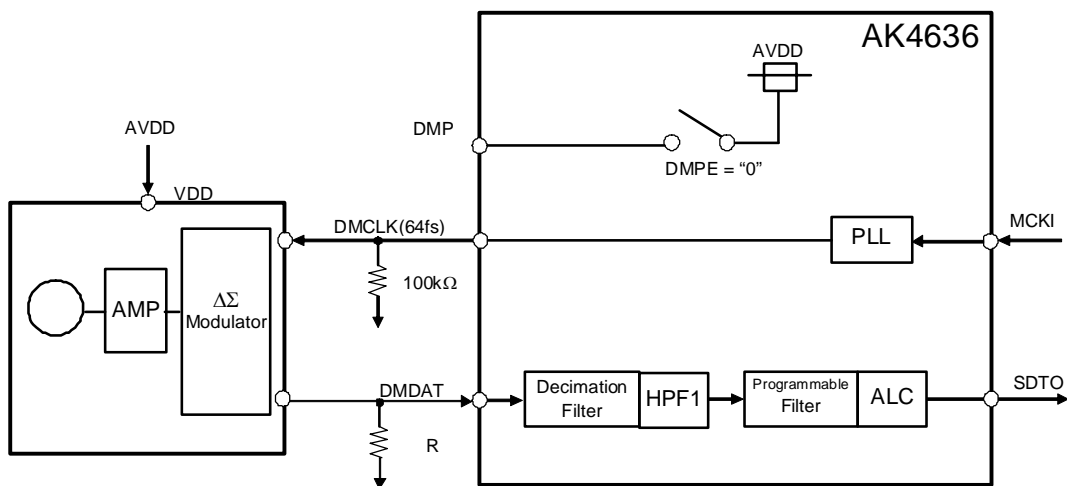

Figure 40. Connection Example of Digital MIC (DMPE bit = "0")

2. Interface

The digital microphone outputs data when DMCLK is “H” by setting DCLKP bit = “1”, and it outputs data when DMCLK is “L” by setting DCLKP bit = “0”. The DMCLK data only supports 64fs. The DMCLK pin outputs is 64fs when DCLKE bit = “1”. In this case, necessary clocks must be supplied to the AK4636 for ADC operation. The DMCLK outputs “L” when DCLKE bit = “0”. Figure 41 and Figure 42 show data input/output timings. When DCLKP bit = “1”, the digital microphone outputs data on the rising edge “↑” of DMCLK and the AK4636 latches data on the falling edge “↓” of DMCLK. When DCLKP bit = “0”, the digital microphone outputs data on the rising edge “↓” of DMCLK and the AK4636 latches data on the falling edge “↑” of DMCLK.

The PDM signal is defined as 0dB (full scale) when the 1 bit data density ranges ±50% from 50%.

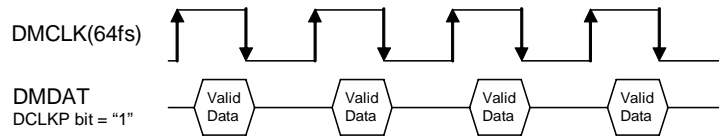

Figure 41. Data In/Output Timing with Digital MIC (DCLKP bit = “1”)

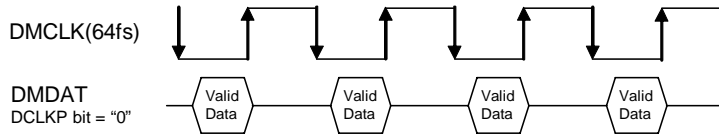
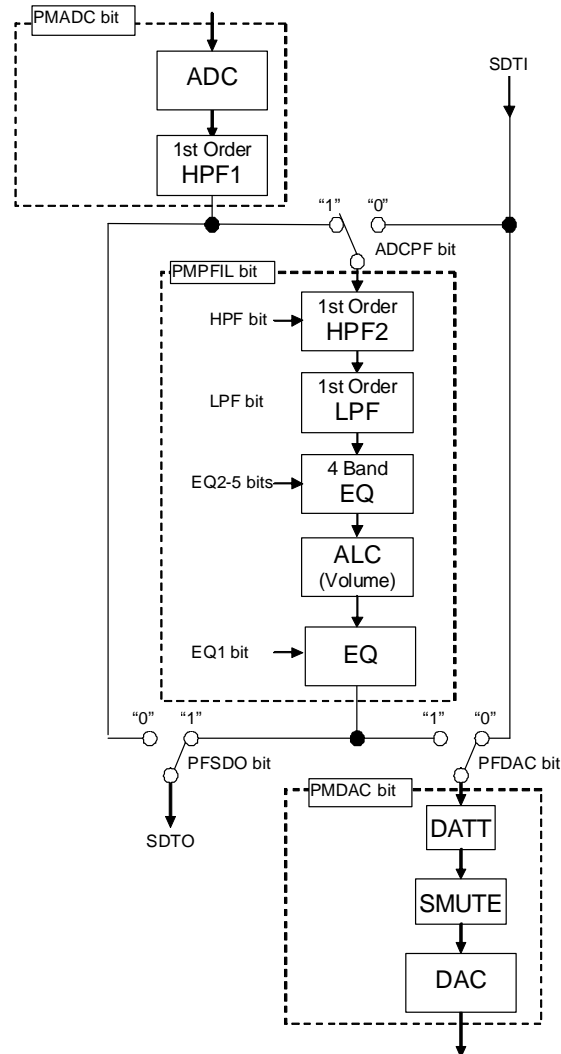

Figure 42. Data In/Output Timing with Digital MIC (DCLKP bit = “0”)

■ Digital Block

The digital block consists of block diagram as shown in Figure 43. The AK4636 can choose signal process path on a recording path or on a playback path by setting ADCPF bit, PFDAC bit and PFSDO bit. (Figure 43 ~ Figure 46, Table 21)



- (1) ADC: Include a Digital Filter (LPF) for ADC as shown in “FILTER CHARACTERISTICS”.
- (2) DAC: Include a Digital Filter (LPF) for DAC as shown in “FILTER CHARACTERISTICS”.
- (3) HPF1/2: High Pass Filter. Applicable to use as Wind-Noise Reduction Filter. (See “Programmable Filter”.)
- (4) LPF: Low Pass Filter (See “Digital Programmable Filter”.)
- (5) 4-Band EQ: Applicable to use as an Equalizer or Notch Filter. (See “Digital Programmable Filter”.)
- (6) ALC: Input Digital Volume with ALC function. (See “Input Digital Volume” and “ALC”.)
- (7) EQ: Applicable to use as an Equalizer or Notch Filter. (See “Digital Programmable Filter”.)
- (8) DATT: 4-step Digital Volume for playback path. (See “Digital Volume 2”)
- (9) SMUTE: Soft mute. (See “Soft Mute”.)

Figure 43. Digital Block Path Select

Mode	ADCPF bit	PFDAC bit	PFSDO bit	Figure
Recording Mode	1	0	1	Figure 44
Playback Mode	0	1	0	Figure 45
Loop Back Mode	1	1	1	Figure 46

(default)

Table 21 Recording Reproduction Mode

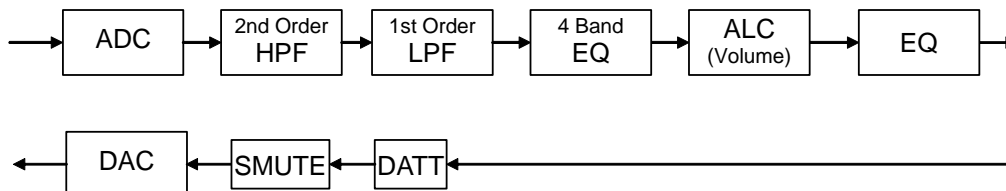

Figure 44. Path at Recording Mode (default)

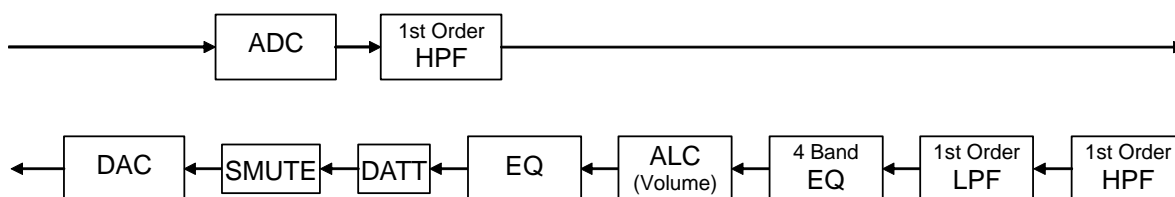

Figure 45. Path at Playback Mode

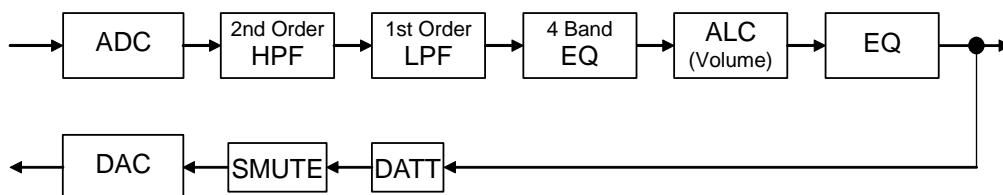

Figure 46. Path at Recording & Playback Mode

■ Digital Programmable Filter Circuit

The AK4636 has 2 steps of 1st order HPF, 1st order LPF and 5-band Equalizer built-in on recording/playback paths.

(1) High Pass Filter (HPF1/2)

Normally, this HPF is used as a Wind-Noise Reduction Filter. This is composed with 2 steps of 1st order HPF. The coefficient of both HPF is the same and set by F1A13-0 bits and F1B13-0 bits. HPF bit controls ON/OFF of the HPF2. When the HPF2 is OFF, the audio data passes this block by 0dB gain. The coefficient should be set when PMADC = PMPFIL bits = "0".

fs : Sampling frequency
fc : Cut-off frequency

Register setting (Note 33)

HPF: F1A[13:0] bits = A, F1B[13:0] bits = B
(MSB = F1A13, F1B13; LSB = F1A0, F1B0)

$$A = \frac{1}{1 + \tan(\pi fc/fs)}, \quad B = \frac{1 - \tan(\pi fc/fs)}{1 + \tan(\pi fc/fs)}$$

Transfer Function

$$H(z) = A \frac{1 - z^{-1}}{1 - Bz^{-1}}$$

The cut-off frequency should be set as below.
 $fc/fs \geq 0.0001$ (fc min = 1.6Hz at fs=16kHz)

(2) Low Pass Filter(LPF)

This is composed with 1st order LPF. F2A13-0 bits and F2B13-0 bits set the coefficient of LPF. LPF bit controls ON/OFF of the LPF. When the LPF is OFF, the audio data passes this block by 0dB gain. The coefficient should be set when LPF bit = "0" or PMPFIL bits = "0".

fs : Sampling frequency
fc : Cut-off frequency

Register setting (Note 33)

LPF: F2A[13:0] bits =A, F2B[13:0] bits =B
(MSB=F2A13, F1B13; LSB=F2A0, F2B0)

$$A = \frac{1}{1 + 1 / \tan(\pi fc/fs)}, \quad B = \frac{1 - 1 / \tan(\pi fc/fs)}{1 + 1 / \tan(\pi fc/fs)}$$

Transfer Function

$$H(z) = A \frac{1 + z^{-1}}{1 + Bz^{-1}}$$

The cut-off frequency should be set as below.
 $fc/fs \geq 0.05$ (fc min = 2205Hz at fs=44.1kHz)

(3) 4-band Equalizer and Equalizer after ALC

This block can be used as Equalizer or Notch Filter. ON/OFF 5-band Equalizer (EQ2, EQ3, EQ4 and EQ5) can be controlled independently by EQ2, EQ3, EQ4 and EQ5 bits. The Equalizer after ALC (EQ1) can be ON/OFF by EQ1 bit. When Equalizer is OFF, the audio data passes this block by 0dB gain. E1A15-0, E1B15-0 and E1C15-0 bits set the coefficient of EQ1. E2A15-0, E2B15-0 and E2C15-0 bits set the coefficient of EQ2. E3A15-0, E3B15-0 and E3C15-0 bits set the coefficient of EQ3. E4A15-0, E4B15-0 and E4C15-0 bits set the coefficient of EQ4. E5A15-0, E5B15-0 and E5C15-0 bits set the coefficient of EQ5. Each EQ coefficient setting should be made when the corresponding EQ bit is "0" or PMPFIL bit "0".

f_s : The Sampling frequency

$f_{o_1} \sim f_{o_5}$: The Center frequency

$f_{b_1} \sim f_{b_5}$: The Band width where the gain is 3dB different from center frequency

$K_1 \sim K_5$: The Gain ($-1 \leq K_n < 3$)

Register setting (Note 33)

EQ1: E1A[15:0] bits = A_1 , E1B[15:0] bits = B_1 , E1C[15:0] bits = C_1

EQ2: E2A[15:0] bits = A_2 , E2B[15:0] bits = B_2 , E2C[15:0] bits = C_2

EQ3: E3A[15:0] bits = A_3 , E3B[15:0] bits = B_3 , E3C[15:0] bits = C_3

EQ4: E4A[15:0] bits = A_4 , E4B[15:0] bits = B_4 , E4C[15:0] bits = C_4

EQ5: E5A[15:0] bits = A_5 , E5B[15:0] bits = B_5 , E5C[15:0] bits = C_5

(MSB=E1A15, E1B15, E1C15, E2A15, E2B15, E2C15, E3A15, E3B15, E3C15, E4A15, E4B15, E4C15, E5A15, E5B15, E5C15;

LSB=E1A0, E1B0, E1C0, E2A0, E2B0, E2C0, E3A0, E3B0, E3C0, E4A0, E4B0, E4C0, E5A0, E5B0, E5C0)

$$A_n = K_n \times \frac{\tan(\pi f_{b_n}/f_s)}{1 + \tan(\pi f_{b_n}/f_s)}, \quad B_n = \cos(2\pi f_{o_n}/f_s) \times \frac{2}{1 + \tan(\pi f_{b_n}/f_s)}, \quad C_n = -\frac{1 - \tan(\pi f_{b_n}/f_s)}{1 + \tan(\pi f_{b_n}/f_s)}$$

($n = 1, 2, 3, 4, 5$)

Transfer Function

$$H(z) = (1 + h_2(z) + h_3(z) + h_4(z) + h_5(z)) \times \{1 + h_1(z)\}$$

$$h_n(z) = A_n \frac{1 - z^{-2}}{1 - B_n z^{-1} - C_n z^{-2}}$$

($n = 1, 2, 3, 4, 5$)

The center frequency should be set as below

$$f_{o_n} / f_s < 0.497$$

When gain of K is set to "-1", the equalizer becomes notch filter. The central frequency of a real notch filter deviates from the above calculation, if the central frequency of each band is near. The control soft that is attached to the evaluation board has a function that revises a gap of frequency, and calculates the coefficient. When the central frequency of each band is near, revise the central frequency and confirm the frequency response.

Note 33.

[Translation the filter coefficient calculated by the equations above from real number to binary code (2's complement)]

$$X = (\text{Real number of filter coefficient calculated by the equations above}) \times 2^{13}$$

X should be rounded to integer, and then should be translated to binary code (2's complement).

MSB of each filter coefficient setting register is sine bit.

■ Input Digital Volume (Manual Mode)

When ADCPF bit = “1” and ALC1 bit = “0”, the ALC block becomes an input digital volume (manual mode). The digital volume’s gain is set by IVOL7-0 bits as shown in Table 22. The IVOL value is changed at zero cross or zero cross time out. The zero crossing timeout period is set by ZTM1-0 bits.

IVOL7-0 bits	GAIN(dB)	Step
F1H	+36.0	0.375dB (default)
F0H	+35.625	
EFH	+35.25	
⋮	⋮	
92H	+0.375	
91H	0.0	
90H	-0.375	
⋮	⋮	
2H	-53.625	
1H	-54.0	
0H	MUTE	

Table 22. Input Digital Volume Setting

When writing to the IVOL7-0 bits continually, the control register should be written in an interval more than zero crossing timeout. If not, a zero crossing counter is reset at each time and the volume will not be changed. However, it could be ignored when writing the same register value as the last time. At this time, zero crossing counter is not reset, so it can be written in an interval less than zero crossing timeout.

■ Output Digital volume (Manual mode)

When ADCPF bit = “0” and ALC2 bit = “0”, the ALC block becomes an output digital volume (manual mode). The digital volume’s gain is set by OVOL7-0 bits as shown in Table 23. The OVOL7-0 bits value are reflected to this output volume at zero cross or zero cross time out. The zero crossing timeout period is set by ZTM1-0 bits.

OVOL7-0 bits	GAIN(dB)	Step
F1H	+36.0	0.375dB (default)
F0H	+35.625	
EFH	+35.25	
:	:	
92H	+0.375	
91H	0.0	
90H	-0.375	
:	:	
2H	-53.625	
1H	-54.0	
0H	MUTE	

Table 23 Output Digital Volume Setting

When writing to the OVOL7-0 bits continually, the control register should be written by an interval more than zero crossing timeout. If not, a zero crossing counter is reset at each time and the volume will not be changed. However, It could be ignored when writing a same register value as the last time. At this time, zero crossing counter is not reset, so it can be written by an interval less than zero crossing timeout.

■ Output Digital Volume2

AK4636 has 4 steps output volume in addition to the volume setting by OVOL7-0 bits. This volume is set by DATT1-0 bits as shown in Table 24.

DATT1-0 bits	GAIN(dB)	Step
0H	0.0	6.0dB (default)
1H	-6.0	
2H	-12.0	
3H	-18.1	

Table 24. Output Digital Volume2 Setting

■ Output Digital Volume3

The AK4636 has a digital output volume (DVOL) with 256 levels in linear steps (Table 24). The volume can be set by the DVL7-0 and DVR7-0 bits. The volume is included in front of a DAC block. The input data of DAC is changed from +0.35 to -47.78dB or MUTE. The volume calculating formula is shown in Table 26.

DVOL7-0 bits	ATT_DATA	GAIN(dB)
FFH	255	+0.35
FEH	254	+0.31
:	:	:
F5H	245	0
:	:	:
02H	2	-41.76
01H	1	-47.78
00H	-	Mute

(default)

Table 25. Output Digital Volume3 Setting

DVOL7-0 bits	GAIN (dB)
FFH	$0.35 + 20 \log_{10} (\text{ATT_DATA} / 255)$
:	
01H	
00H	Mute

Table 26. Output Digital Volume3 Formula

■ ALC Operation

The ALC (Automatic Level Control) is operated by ALC block. When ADCPF bit = "1", ALC operation is enable at recording path. When ADCPF bit = "0", ALC operation is enable at playback path. ON/OFF switching of ALC operation is controlled by ALC1 bit for recording and ALC2 bit for playback.

1. ALC Limiter Operation

During the ALC limiter operation, if the output data exceeds the ALC limiter detection level (Table 27), the volume value is automatically attenuated by the amount defined in LMAT1-0 bits (Table 28).

When ZELMN bit = "0" (zero cross detection valid), the IVL and VOL value is changed by ALC limiter operation at the individual zero crossing points of Lch and Rch or at the zero crossing timeout. ZTM1-0 bits set the zero crossing timeout period of both ALC limiter and recovery operation (Table 29). When ALC output level exceeds full-scale at LFST bit = "1", VOL value is immediately (Period: 1/fs) changed in 1 step. When ALC output level is less than full-scale, VOL value is changed at the individual zero crossing point of each channels or at the zero crossing timeout.

When ZELMN bit = "1" (zero cross detection invalid), VOL value is immediately (period: 1/fs) changed by ALC limiter operation. Attenuation step is fixed to 1 step regardless of the setting of LMAT1-0 bits.

After completing the attenuate operation, unless ALC bit is changed to "0", the operation repeats when the input signal level exceeds the ALC limiter detection level.

LMTH1	LMTH0	ALC Limiter Detection Level	ALC Recovery Waiting Counter Reset Level
0	0	ALC Output $\geq -2.5\text{dBFS}$	$-2.5\text{dBFS} > \text{ALC Output} \geq -4.1\text{dBFS}$
0	1	ALC Output $\geq -4.1\text{dBFS}$	$-4.1\text{dBFS} > \text{ALC Output} \geq -6.0\text{dBFS}$
1	0	ALC Output $\geq -6.0\text{dBFS}$	$-6.0\text{dBFS} > \text{ALC Output} \geq -8.5\text{dBFS}$
1	1	ALC Output $\geq -8.5\text{dBFS}$	$-8.5\text{dBFS} > \text{ALC Output} \geq -12\text{dBFS}$

(default)

Table 27. ALC Limiter Detection Level / Recovery Waiting Counter Reset Level

LMAT1	LMAT0	ALC1 Limiter ATT Step			
		ALC1 Output $\geq \text{LMTH}$	ALC1 Output $\geq \text{FS}$	ALC1 Output $\geq \text{FS} + 6\text{dB}$	ALC1 Output $\geq \text{FS} + 12\text{dB}$
0	0	1	1	1	1
0	1	2	2	2	2
1	0	2	4	4	8
1	1	1	2	4	8

(default)

Table 28. ALC Limiter ATT Step Setting

ZTM1	ZTM0	Zero Crossing Timeout Period			
			8kHz	16kHz	44.1kHz
0	0	128/fs	16ms	8ms	2.9ms
0	1	256/fs	32ms	16ms	5.8ms
1	0	512/fs	64ms	32ms	11.6ms
1	1	1024/fs	128ms	64ms	23.2ms

(default)

Table 29. ALC Zero Crossing Timeout Period Setting

2. ALC Recovery Operation

The ALC recovery operation waits for the WTM2-0 bits (Table 30) to be set after completing the ALC limiter operation. If the input signal does not exceed “ALC recovery waiting counter reset level” (Table 27) during the wait time, the ALC recovery operation is executed. The VOL value is automatically incremented by RGAIN1-0 bits (Table 31) up to the set reference level (Table 32, Table 33) with zero crossing detection which timeout period is set by ZTM1-0 bits (Table 29). The ALC recovery operation is executed in a period set by WTM2-0 bits.

For example, when the current VOL value is 30H and RGAIN1-0 bits are set to “01”(2 steps), VOL is changed to 32H by the auto limiter operation and then the input signal level is gained by 0.75dB (=0.375dB x 2). When the VOL value exceeds the reference level (IREF7-0 or OREF5-0), the VOL values are not increased.

When

“ALC recovery waiting counter reset level (LMTH1-0) ≤ Output Signal < ALC limiter detection level (LMTH1-0)” during the ALC recovery operation, the waiting timer of ALC recovery operation is reset. When

“ALC recovery waiting counter reset level (LMTH1-0) > Output Signal”, the waiting timer of ALC recovery operation starts.

The ALC operation corresponds to the impulse noise. When the impulse noise is input, the ALC recovery operation becomes faster than a normal recovery operation. When large noise is input to microphone instantaneously, the quality of small level in the large noise can be improved by this fast recovery operation. The speed of first recovery operation is set by RFST1-0 bits (Table 34).

WTM2	WTM1	WTM0	ALC Recovery Operation Waiting Period			(default)
				8kHz	16kHz	
0	0	0	128/fs	16ms	8ms	2.9ms
0	0	1	256/fs	32ms	16ms	5.8ms
0	1	0	512/fs	64ms	32ms	11.6ms
0	1	1	1024/fs	128ms	64ms	23.2ms
1	0	0	2048/fs	256ms	128ms	46.4ms
1	0	1	4096/fs	512ms	256ms	92.9ms
1	1	0	8192/fs	1024ms	512ms	185.8ms
1	1	1	16384/fs	2048ms	1024ms	371.5ms

Table 30. ALC Recovery Operation Waiting Period

RGAIN1	RGAIN0	GAIN STEP		(default)
0	0	1	0.375dB	
0	1	2	0.750dB	
1	0	3	1.125dB	
1	1	4	1.500dB	

Table 31. ALC Recovery GAIN Step

IREF7-0 bits	GAIN(dB)	Step
F1H	+36.0	0.375dB (default)
F0H	+35.625	
EFH	+35.25	
:	:	
C5H	+19.5	
:	:	
92H	+0.375	
91H	0.0	
90H	-0.375	
:	:	
2H	-53.625	
1H	-54.0	
0H	MUTE	

Table 32. Reference Level at ALC Recovery operation for recoding

OREF5-0 bits	GAIN(dB)	Step
3CH	+36.0	1.5dB (default)
3BH	+34.5	
3AH	+33.0	
:	:	
28H	+6.0	
:	:	
25H	+1.5	
24H	0.0	
23H	-1.5	
:	:	
2H	-51.0	
1H	-52.5	
0H	-54.0	

Table 33. Reference Level at ALC Recovery operation for playback

RFST1 bit	RFST0 bit	Recovery Speed
0	0	4 times
0	1	8 times
1	0	16times
1	1	N/A

Table 34. First Recovery Speed Setting (N/A: Not available)

3. The Volume at the ALC Operation

The current volume value at the ALC operation is reflected in VOL7-0 bits. It is enable to check the current volume value by reading the register value of VOL7-0 bits. (Since data reading for I²C bus control mode is not supported, the register values are invalid when reading the VOL7-0 bits.)

VOL7-0 bits	GAIN(dB)
F1H	+36.0
F0H	+35.625
EFH	+35.25
:	:
C5H	+19.5
:	:
92H	+0.375
91H	0.0
90H	-0.375
:	:
2H	-53.625
1H	-54.0
0H	MUTE

Table 35. Value of VOL7-0 bits

4. Example of the ALC Operation for Recording

Table 36 shows the examples of the ALC setting for a microphone recording.

Register Name	Comment	fs=8kHz		fs=16kHz	
		Data	Operation	Data	Operation
LMTH1-0	Limiter detection Level	01	-4.1dBFS	01	-4.1dBFS
ZELM	Limiter zero crossing detection	0	Enable	0	Enable
ZTM1-0	Zero crossing timeout period	00	16ms	01	16ms
WTM2-0	Recovery waiting period *WTM1-0 bits should be more than or equal to ZTM1-0 bits	000	16ms	001	16ms
IREF7-0	Maximum gain at recovery operation	C5H	19.5dB	C5H	19.5dB
IVOL7-0	Gain of IVOL	C5H	19.5dB	C5H	19.5dB
LMAT1-0	Limiter ATT step	00	1step	00	1step
LFST	Fast Limiter Operation	1	ON	1	ON
RGAIN1-0	Recovery GAIN step	00	1 step	00	1 step
ALC1	ALC enable	1	Enable	1	Enable
FRSL1-0	Speed of Fast Recovery	00	4 times	00	4times

Table 36. Example of the ALC Setting (Recording)

5. Example of ALC for Playback Operation

Table 37 shows the example of the ALC setting for playback.

Register Name	Comment	fs=8kHz		fs=16kHz	
		Data	Operation	Data	Operation
LMTH1-0	Limiter detection Level	01	-4.1dBFS	01	-4.1dBFS
ZELM	Limiter zero crossing detection	0	Enable	0	Enable
ZTM1-0	Zero crossing timeout period	00	16ms	01	16ms
WTM2-0	Recovery waiting period *WTM1-0 bits should be more than or equal to ZTM1-0 bits	000	16ms	001	16ms
OREF5-0	Maximum gain at recovery operation	28	+6dB	28	+6dB
OVOL7-0	Gain of IVOL	91	0dB	91	0dB
LFST	Fast Limiter Operation	1	ON	1	ON
LMAT1-0	Limiter ATT step	00	1step	00	1step
RGAIN1-0	Recovery GAIN step	00	1 step	00	1 step
ALC2	ALC enable	1	Enable	1	Enable
FRSL1-0	Speed of Fast Recovery	00	4 times	00	4 times

Table 37. Examples of the ALC Setting (Playback)

6. Noise Suppression

The Noise Suppression is enabled when NSCE bit (Noise suppression enable bit) = “1” during ALC operation (ALC1 bit = “1”). This function attenuates output signal level automatically when minute amount of the signal is input.

NSCE bit: Noise Suppression Enable
 0: Disable (default)
 1: Enable

(1) Noise Level Suppressing Operation

The output signal (Note 34) is suppressed when the input peak level is lower than “Noise Suppression Threshold Low Level” set by NSTHL3-0 bits (Table 38) during the waiting time set by WTM2-0 bits (Table 30).

VOL value is changed by this noise suppressing operation only at the individual zero crossing points of Lch and Rch or at the zero crossing timeout. Noise level suppressing operation has common zero cross timeout period to ALC recovery operation which is set by ZTM1-0 bits. (Table 29)

This operation sets the volume automatically to the reference level (Table 42) with zero cross detection in the period which is set by ZTM1-0 bits (Table 29). It is executed in the cycle of WTM2-0 bits settings.

Note 34. When the input signal volume is smaller than the value set by NSREF7-0 bits, normal ALC recovery operation is executed.

NSTHL3	NSTHL2	NSTHL1	NSTHL0	Noise Suppression Threshold Low Level	Step
0	0	0	0	-81dB	3dB (default)
0	0	0	1	-78dB	
0	0	1	0	-75dB	
0	0	1	1	-72dB	
0	1	0	0	-69dB	
0	1	0	1	-66dB	
0	1	1	0	-63dB	
0	1	1	1	-60dB	
1	0	0	0	-57dB	
1	0	0	1	-54dB	
1	0	1	0	-51dB	

Table 38. Noise Suppression Threshold Low Level

NATT1 bit	NATT0 bit	ATT STEP
0	0	1/4 (Note 35)
0	1	1/2 (Note 36) (default)
1	0	1
1	1	2

Table 39. Noise ATT Settings

Note 35. 1step attenuated in 4 x “WTM cycles”.

Note 36. 1step attenuated in 2 x “WTM cycles”.

ZTM1 bit	ZTM0 bit	Zero Cross Timeout Period			
			8kHz	16kHz	44.1kHz
0	0	128/fs	16ms	8ms	2.9ms
0	1	256/fs	32ms	16ms	5.8ms
1	0	512/fs	64ms	32ms	11.6ms
1	1	1024/fs	128ms	64ms	23.2ms

(default)

Table 29. ALC Zero Cross Timeout Period Settings

(2) Noise Level Hold

During the waiting time set by WTM2-0 bits (Table 3), VOL values are kept when the input signal peak level is in between the set value of NSTHH1-0 (Note 37) and Noise Suppression Threshold Low Level (Noise Suppression High Level > input signal level ≥ Noise Suppression Threshold Low Level) therefore the output signal level does not change.

NSTHH1 bit	NSTHH0 bit	Noise Suppression High Level (Note 37)
0	0	NSTHL3-0bits + 3dB
0	1	NSTHL3-0bits + 6dB
1	0	NSTHL3-0bits + 9dB
1	1	NSTHL3-0bits + 12dB

(default)

Note 37. Noise Suppression Threshold Low Level (NSTHL3-0 bits) + Gain (NSTHH1-0 bits) = Noise Suppression High Level

Table 40. Noise Suppression High Level Settings

(3) Noise Suppression → Normal ALC Operation

During noise suppressing operation, if the input signal level exceeds Noise Suppression High Level, the operation switches to normal ALC operation from noise suppressing or noise level hold operation. In this case, recovery speed is faster than the normal recovery. (Table 41)

When the internal volume level is lower than noise suppressing operation reference level (set by NSREF7-0 bits), the recovery speed to ALC operation from noise suppressing operation is the same as normal ALC recovery speed.

NSGAIN1 bit	NSGAIN0 bit	Recovery Speed
0	0	8 step
0	1	12 step
1	0	16 step
1	1	28 step

(default)

Table 41. Fast Recovery Speed Setting from Noise Suppression to ALC Operation

NSREF7-0 bits	GAIN[dB]	Step
F1H	+36.0	0.375dB (default)
F0H	+35.625	
EFH	+35.25	
:	:	
C5H	+19.5	
:	:	
92H	+0.375	
91H	0.0	
90H	-0.375	
:	:	
2H	-53.625	
1H	-54.0	
0H	MUTE	

Table 42. Reference Value Setting when Noise Suppression is ON

7. Example of ALC Operation

The following registers must not be changed during the ALC operation. These bits should be changed, after the ALC operation is finished by ALC1 bit = ALC2 bit = "0" or PMPFIL bit = "0". When ALC is restarted, after ALC1 bit and ALC2 bit set to "0" or PMPFIL bit sets to "0", the waiting time of zero crossing timeout is not needed.

LMTH1-0, LMAT1-0, WTM2-0, ZTM1-0, RGAIN1-0, IREF7-0/OREF5-0, ZELM, RFST1-0, LFST, NSCE, NSTHL3-0, NSTHH1-0, NSGAIN1-0, NSREF7-0 bits

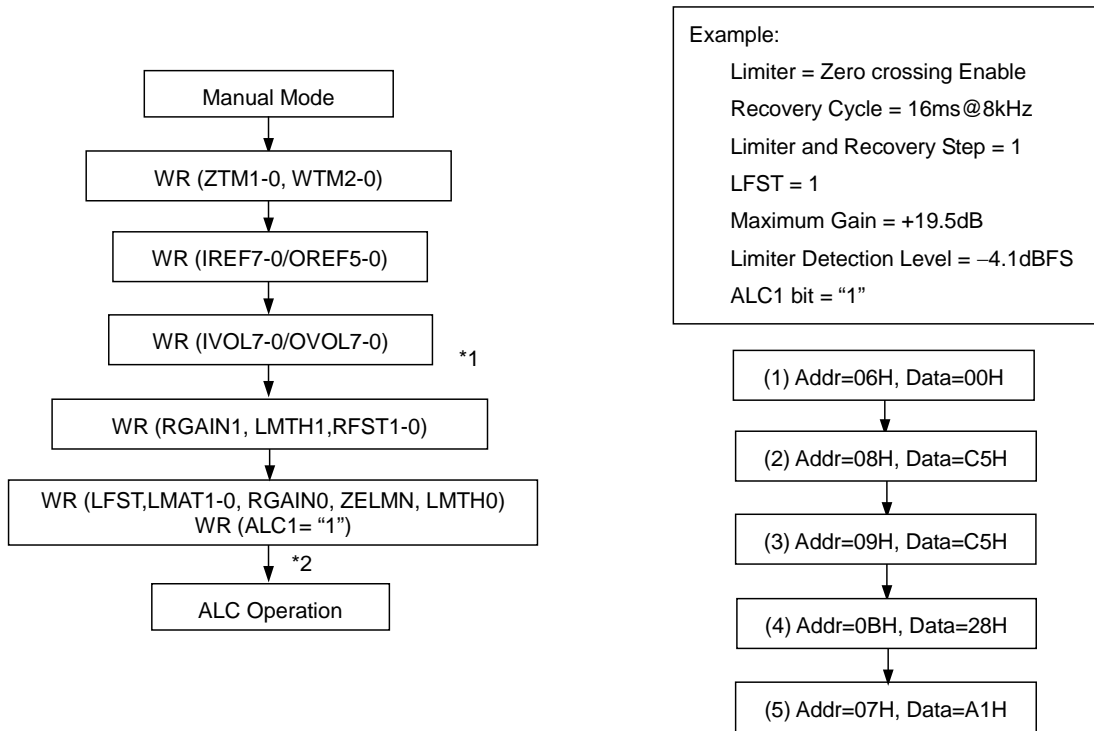

Note. WR: Write

*1: The value of volume at starting should be the same or smaller than REF's.

*2: When setting ALC1 bit or ALC2 bit to "0", the operation is shifted to manual mode after passing the zero crossing time set by ZTM1-0 bits.

Figure 47. Registers set-up sequence at the ALC operation

■ SOFTMUTE

Soft mute operation is performed in the digital input domain. When the SMUTE bit changes to “1”, the input signal is attenuated by $-\infty$ (“0”) in $245/f_s$ cycles ($31\text{msec}@f_s=8\text{kHz}$, DVOL bits = F5H). When the SMUTE bit is returned to “0”, the mute is cancelled and the input attenuation gradually changes to 0dB in $245/f_s$ cycles ($31\text{msec}@f_s=8\text{kHz}$, DVOL bits = F5H). If the soft mute is cancelled within the $245/f_s$ cycles ($31\text{msec}@f_s=8\text{kHz}$, DVOL bits = F5H), the attenuation is discontinued and returned to 0dB. The soft mute for Playback operation is effective for changing the signal source without stopping the signal transmission.

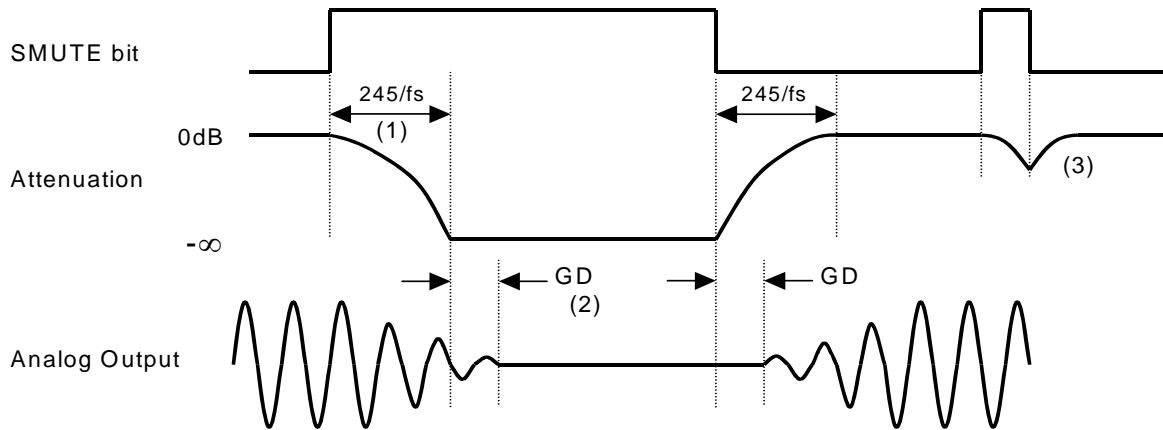

Figure 48. Soft Mute Function

- (1) The input signal is attenuated by $-\infty$ (“0”) in $245/f_s$ cycles ($31\text{msec}@f_s=8\text{kHz}$, DVOL bits = F5H).
- (2) Analog output corresponding to digital input has group delay (GD).
- (3) If the soft mute is cancelled within the $245/f_s$ cycles ($31\text{msec}@f_s=8\text{kHz}$, DVOL bits = F5H), the attenuation is discontinued and returned to 0dB within the same cycle.

■ BEEP input and Generating Circuit

The AK4636 has the BEEP pin (external signal input pin) and BEEP generating circuit. BEEP Mode can be set by BPM1-0 bits.

BPM1 bit	BPM0 bit	BEEP Mode
0	0	Disable
0	1	BEEP pin (Internal Resisitance mode)
1	0	BEEP pin (External Resisitance mode)
1	1	BEEP Generator mode

(default)

Table 43. BEEP Mode Settings

1. BEEP input pin (BPM1-0 bits = “01” or “10”)

When BMP1-0 bits = “01” or “10”, the input signal to BEEP pin is output from the speaker amplifier by setting BEEPS bits to “1”, and it is output from Mono lineout amplifier by setting BEEPA bit to “1”.

BPM1-0 bits = “10”

R_i can control the BEEP signal gain which is in invert proportional to R_i resistor value (Figure 49). The gain setting can not be made by BPLVL2-0 bits.

BPM1-0 bits = “01”

The BEEP signal gain is controlled by BPLVL2-0 bits (Table 46). R_i is not necessary.

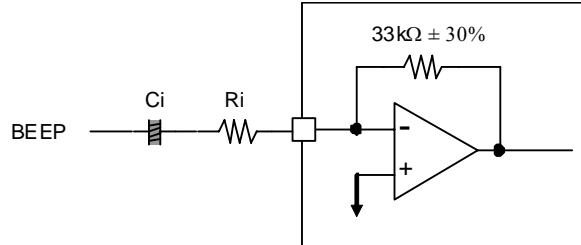

Figure 49. Block Diagram of BEEP pin (BPM1-0 bits = “10”)

SPKG1-0 bits	BEEP → SPP/SPN Gain
00	+10.6dB
01	+12.6dB
10	+14.6dB
11	+16.6dB

Table 44. BEEP → SPK Output Gain

LOVL bit	BEEP → AOUT Gain
0	0dB
1	+3dB

Table 45. BEEP → AOUT Output Gain

BPLVL2	BPLVL1	BPLVL0	BEEP Gain	AOUT (LOVL bit="0")	SPK (SPKG1-0 bits = "00")
0	0	0	0dB	1.5Vpp	5.08Vpp
0	0	1	-3dB	1.06Vpp	3.60Vpp
0	1	0	-6dB	0.75Vpp	2.55Vpp
0	1	1	-12dB	0.38Vpp	1.28Vpp
1	0	0	-18dB	0.19Vpp	0.64Vpp
1	0	1	-23dB	0.10Vpp	0.36Vpp
1	1	0	-29dB	0.05Vpp	0.18Vpp
1	1	1	-34dB	0.03Vpp	0.10Vpp

Table 46. BEEP Output Gain Setting when BPM 1-0 bits = "01" (BEEP input =1.5Vpp)

2. BEEP Signal Generating Circuit

The AK4636 integrates a BEPP signal generating circuit. When BPM 1-0 bits = "11", the speaker amplifier outputs BEEP signal by setting BEEPS bit = "1", and the Mono lineout amplifier outputs BEEP signal by setting BEEPA bit = "1".

After outputting the signal during the time set by BPON7-0 bits, the AK4636 stops the output signal during the time set by BPOFF7-0 bits (Figure 50). The repeat count is set by BPTM6-0 bit, and the output level is set by BPLVL2-0 bits. When BPCNT bit is "0", if BPOUT bit is written "1", the AK4636 outputs the beep for the times of repeat count. When the output is finished, BPOUT bit is set to "0" automatically. When BPCNT bit is set to "1", it outputs the beep in succession regardless of repeat count, on-time and off-time. The output frequency is set by BPFR1-0 bits.

< Setting parameter >

- 1) Output Frequency (Table 47 ~ Table 49)
- 2) ON Time (Table 50)
- 3) OFF Time (Table 51)
- 4) Repeat Count (Table 52)
- 5) Output Level (Table 53)

- * **BPFR1-0, BPON7-0, BPOFF7-0, BPTM6-0 and BPLVL3-0 bits should be set when BPOUT =BPCNT = "0".**
- * **BPCNT bit is given priority in BPOUT bit. When BPOUT bit be set to "1", if BPCNT bit is set to "0", BPOUT bit is set to "0" forcibly.**
- * **When stopping the BEEP outputs by changing BPCNT bit to "0" from "1", writing to BPOUT bit and BPCNT bit are inhibited for 10ms.**

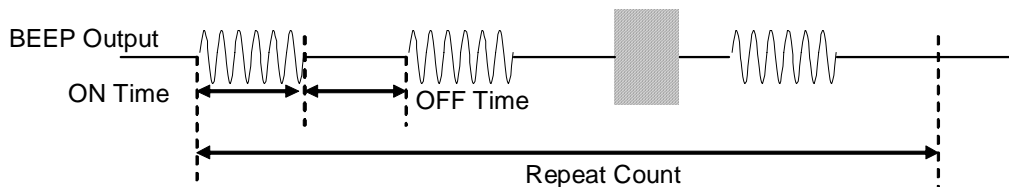

Figure 50. BEEP Signal Output

BPFR1-0 bit	Output frequency of BEEP Generator [Hz]	
	fs = 48kHz system (Note 38)	fs = 44.1kHz system (Note 39)
00	4000	4009
01	2000	2005
10	1000	1002
11	N/A	

(default)

Note 38. Sampling frequency is 8kHz, 16kHz, 32kHz or 48kHz.

Note 39. Sampling frequency is 11.025kHz, 22.05kHz or 44.1kHz.

Table 47. Beep signal frequency (PLL Master/Slave Mode: reference clock: MCKI) (N/A: Not available)

BPFR1-0 bit	Output frequency of BEEP Generator [Hz]		
	FS3-2 bits = "00"	FS3-2 bits = "01"	FS3-2 bits = "10"
00	fs/2.75	fs/5.5	fs/11
01	fs/5.5	fs/11	fs/22
10	fs/11	fs/22	fs/44
11	N/A		

(default)

Table 48. Beep signal frequency (PLL Slave Mode: reference clock : FCK/BICK) (N/A: Not available)

BPFR1-0 bit	Output frequency of BEEP Generator [Hz]			
	FS1-0 bits = "00"	FS1-0 bits = "01"	FS1-0 bits = "10"	FS1-0 bits = "11"
00	fs/11	fs/2.75	fs/55	fs/11
01	fs/22	fs/5.5	fs/11	fs/22
10	fs/44	fs/11	fs/22	fs/44
11	N/A			

(default)

Table 49. Beep signal frequency (EXT Slave/Master Mode) (N/A: Not available)

BPON7-0 bit	ON Time of BEEP Generator [msec]		Step [msec]	
	fs = 48kHz system (Note 38)	fs = 44.1kHz system (Note 39)	fs = 48kHz system (Note 38)	fs = 44.1kHz system (Note 39)
0H	8.0	7.98	8.0	7.98
1H	16.0	15.86		
2H	24.0	23.95		
3H	32.0	31.93		
4H	40.0	39.9		
:	:			
FDH	2032	2027.3		
FEH	2040	2035.3		
FFH	2048	2043.4		

(default)

Note 38. Sampling frequency is 8kHz, 16kHz, 32kHz or 48kHz.

Note 39. Sampling frequency is 11.025kHz, 22.05kHz or 44.1kHz.

Table 50. Beep output ON-time (PLL Master/Slave Mode reference clock: MCKI)

BPOFF7-0 bit	OFF Time of BEEP Generator [msec]		Step [msec]		(default)
	fs = 48kHz system (Note 38)	fs = 44.1kHz system (Note 39)	fs = 48kHz system (Note 38)	fs = 44.1kHz system (Note 39)	
0H	8.0	7.98	8.0	7.98	
1H	16.0	15.86			
2H	24.0	23.95			
3H	32.0	31.93			
4H	40.0	39.9			
:	:	:			
FDH	2032	2027.3			
FEH	2040	2035.3			
FFH	2048	2043.4			

Note 38. Sampling frequency is 8kHz, 16kHz, 32kHz or 48kHz.

Note 39. Sampling frequency is 11.025kHz, 22.05kHz or 44.1kHz.

Table 51. Beep output OFF-time (PLL Master/Slave Mode reference clock: MCKI)

BPTM6-0 bit	Repeat Count	(default)
0H	1	
1H	2	
2H	3	
3H	4	
:	:	
7DH	126	
7EH	127	
7FH	128	

Table 52. Beep output Repeat Count

BPLVL2-0 bits	Beep Output Level	STEP	(default)
0H	0dB	3dB	
1H	-3dB		
2H	-6dB		
3H	-12dB	6dB	
4H	-18dB		
5H	-23dB	5dB	
6H	-29dB	6dB	
7H	-34dB	5dB	

Note 40. Beep output amplitude in 0dB setting is 1.5Vpp (LOVL bit = "0") from AOUT, and 5.08Vpp @8Ω (SPKG1-0 bits = "00") from the speaker amplifier.

Table 53. Beep Output Level

■ MONO LINE OUTPUT (AOUT pin)

A signal of DAC is output from the AOUT pin. When the DACA bit is “0”, this output is OFF. When the LOVL bit is “1”, this gain changes to +3dB (large amplitude outputs may clip). The load resistance is 10kΩ(min). When PMAO bit is “0” and AOPS bit is “0”, the mono line output enters power-down state and it is pulled down by 100Ω(typ). If PMAO bit is controlled when AOPS bit = “1”, POP noise will be reduced at power-up and down. Then, this line should be pulled down by 20kΩ of resistor after C-coupling shown in Figure 51. This rising and falling time is max 300 ms at C = 1.0μF. When PMAO bit is “1” and AOPS bit is “0”, the mono line output enters power-up state.

DAC	AOUT		
Input Level	LOVL bit	Gain	OUT
0dBFS	0	0dB	1.5Vpp (default)
	1	+3dB	2.12Vpp

Table 54. Mono Line Output Volume Setting

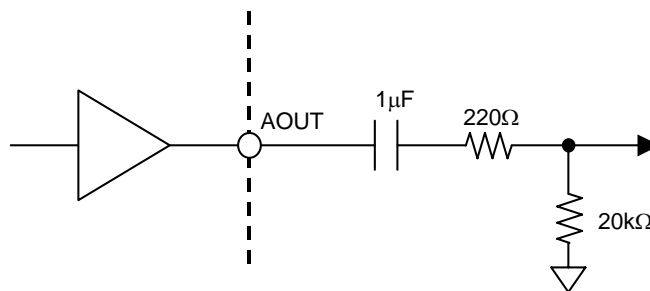

Figure 51. AOUT External Circuit when Using POP Reduction Function

AOUT Control Sequence in case of using POP Reduction Circuit

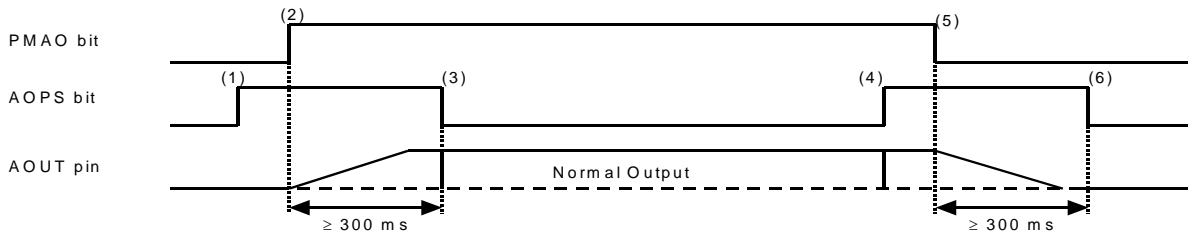

Figure 52. Mono Line Output Control Sequence when using POP Reduction Function

- (1) Set AOPS bit = “1”. Mono line output enters the power-save mode.
- (2) Set PMAO bit = “1”. Mono line output exits the power-down mode.
AOUT pin rises up to VCOM voltage. Rise time is 200ms (max 300ms) at C=1μF.
- (3) Set AOPS bit = “0” after AOUT pin rises up. Mono line output exits the power-save mode.
Mono line output is enabled.
- (4) Set AOPS bit = “1”. Mono line output enters power-save mode.
- (5) Set PMAO bit = “1”. Mono line output enters power-down mode.
AOUT pin falls down to VSS1. Fall time is 200ms (max 300ms) at C=1μF.
- (6) Set AOPS bit = “0” after AOUT pin falls down. Mono line output exits the power-save mode.

■ Speaker Output

AK4636 has a Mono Class-D Speaker-Amp. Power supply for Speaker-Amp can be set from 2.6V up to 3.6V.

The output signal from DAC is input to the Speaker-amp. This Speaker-amp is a mono output controlled by BTL and the gain of Speaker-Amp is set by SPKG1-0 bits. The output voltage is depend on SPKG1-0 bits.

DAC		SPK-amp			(default)
Output Level		SPKG1-0 bits	Gain	OUT (R=8Ω)	
-4.1dBFS	0.94Vpp	00	10.6dB	3.17Vpp	157mW
		01	12.6dB	4.00Vpp	250mW
		10	14.6dB	5.03Vpp	395mW
		11	N/A	N/A	N/A

Note 41. The setting of SPKG1-0 bits = "01" is recommended when 8Ω dynamic speaker is connected. The SPK-Amp Power is 250mW at 8Ω Load Resistance and 4.0Vpp output level.

Table 55. SPK- Amp Gain

< Speaker-Amp Control Sequence >

Speaker-Amp is powered-up/down by PMSPK bit. When PMSPK bit is "0", both SPP and SPN pins are in Hi-Z state. When PMSPK bit is "1" and SPPSN bit is "0", the Speaker-Amp enters power-save mode. In this mode, the SPP pin is placed in Hi-Z state and the SPN pin outputs SVDD/2 voltage.

When the PMSPK bit is "1" after the PDN pin is changed from "L" to "H", the SPP and SPN pins are powered-up in power-save-mode. In this mode, the SPP pin is placed in a Hi-Z state and the SPN pin goes to SVDD/2 voltage and pop noise can be reduced. When the AK4646 is powered-down, pop noise can be also reduced by first entering power-save-mode.

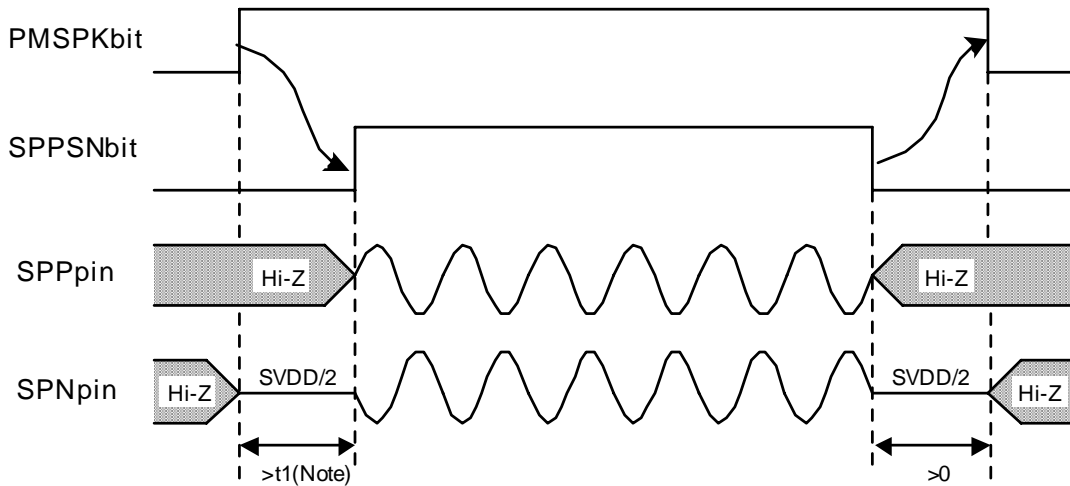

(Note)

SPPSN bit should be set to "1" at more than 1ms after PMSPK bit is set to "1". When BEEP Input Amp and Speaker Amp are powered-up at the same time, SPPSN bit should be set to "1" after BEEP Input become stable. When the resistance and capacitance of BEEP pin are R=33kΩ and C=0.1μF, 16.5ms(=5τ) is required for BEEP Input to become stable.

Figure 53. Power-up/Power-down Timing for Speaker-Amp

■ Video Block

The AK4636 has a Video-Amp with drivability for a load resistance of 150Ω. It has a composite input and output. A Low Pass Filter (LPF) and Gain Control Amp (GCA) are integrated and DC output is supported as shown in Figure 54. The output clamp voltage is 50 mV(typ) at DC output. The gain control and the step are shown in Table 56. The gain can be set by VGCA4-0 bits. PMV bit controls the power up and down of the video block. The VOUT pin outputs 0V at PMV bit = “0”. When no data is input to the VIN pin, PMV bit must be “0”.

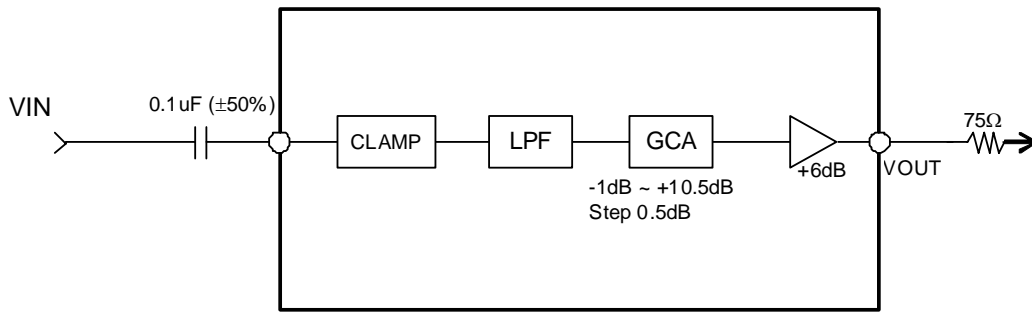

Figure 54. Video Block

VGCA4-0 bits	GAIN(dB)	STEP
17H	+10.5dB	0.5dB (default)
16H	+10.0dB	
15H	+9.5dB	
⋮	⋮	
04H	+1.0dB	
03H	+0.5dB	
02H	0.0dB	
01H	-0.5dB	
00H	-1.0dB	

Table 56. Recommended Value of Video Input Resistance

■ Video Input

The video input signals must be C coupled by a 0.1μF (±50%) capacitor. The output impedance of video input signal source should be 30Ω~390Ω(±5%).

■ Serial Control Interface

(1) 3-wire Serial Control Mode

Internal registers may be written and read by the 3-wire μ P interface pins (CSN, CCLK and CDTIO). The data on this interface consists of Read/Write, Register address (MSB first, 7bits) and Control data (MSB first, 8bits). Address and data is clocked in on the rising edge of CCLK and data is clocked out on the falling edge. Data writing is valid on the rising edge of the 16th CCLK after the falling edge of CSN. In reading operation, the CDTIO pin changes to output mode at the falling edge of 8th CCLK and outputs D7-D0. The output finishes on the rising edge of CSN. However this reading function is available only at READ bit = "1". When READ bit = "0", the CDTIO pin stays as Hi-Z even after the falling edge of 8th CCLK. The CDTIO pin is placed in a Hi-Z state except outputting data at read operation mode. The clock speed of CCLK is 5MHz (max). The value of internal registers is initialized at the PDN pin = "L".

Note 42. A read operation is available at 00H ~ 11H, 1CH ~ 24H and 27H~30H addresses. When reading the address 12H ~ 1BH, 25H ~ 26H and 31H ~ 4FH, the register values are invalid.

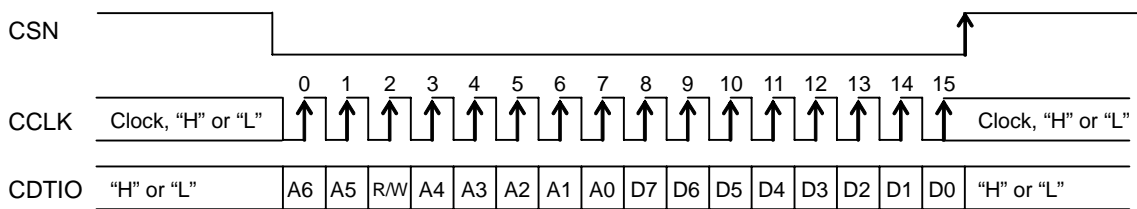

R/W: READ/WRITE ("1": WRITE, "0": READ)
 A6-A0: Register Address
 D7-D0: Control data

Figure 55. Serial Control I/F Timing

(2) I²C-bus Control Mode (I2C pin = "H")

The AK4636 supports the fast-mode I²C-bus (max: 400kHz). Pull-up resistors at SDA and SCL pins should be connected to (DVDD+0.3)V or less voltage.

(2)-1. WRITE Operations

Figure 56 shows the data transfer sequence for I²C-bus mode. All commands are preceded by START condition. A HIGH to LOW transition on the SDA line while SCL is HIGH indicates START condition (Figure 62). After the START condition, a slave address is sent. This address is 7 bits long followed by the eighth bit that is a data direction bit (R/W). The most significant seven bits of the slave address are fixed as "0010010" (Figure 57). If the slave address matches that of the AK4636, the AK4636 generates an acknowledge and the operation is executed. The master must generate the acknowledge-related clock pulse and release the SDA line (HIGH) during the acknowledge clock pulse (Figure 63). A R/W bit value of "1" indicates that the read operation is to be executed. A "0" indicates that the write operation is to be executed.

The second byte consists of the control register address of the AK4636. The format is MSB first, and those most significant 1-bits are fixed to zeros (Figure 58). The data after the second byte contains control data. The format is MSB first, 8bits (Figure 59). The AK4636 generates an acknowledge after each byte is received. A data transfer is always terminated by STOP condition generated by the master. A LOW to HIGH transition on the SDA line while SCL is HIGH defines STOP condition (Figure 62).

The AK4636 can perform more than one byte write operation per sequence. After receipt of the third byte the AK4636 generates an acknowledge and awaits the next data. The master can transmit more than one byte instead of terminating the write cycle after the first data byte is transferred. After receiving each data packet the internal 6-bit address counter is incremented by one, and the next data is automatically taken into the next address. If the address exceeds 4FH prior to generating stop condition, the address counter will "roll over" to 00H and the previous data will be overwritten.

The data on the SDA line must remain stable during the HIGH period of the clock. The HIGH or LOW state of the data line can only change when the clock signal on the SCL line is LOW (Figure 64) except for the START and STOP conditions.

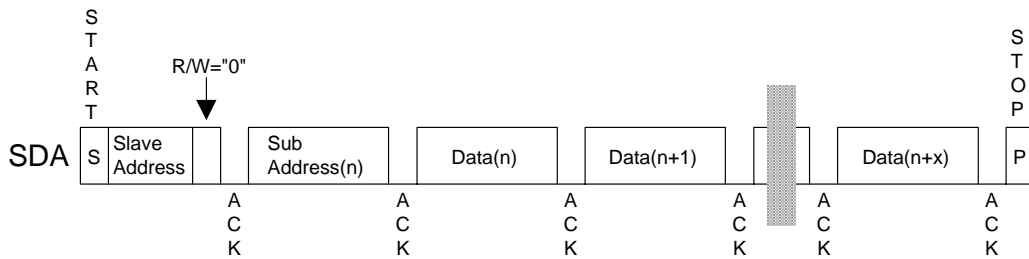

Figure 56. Data Transfer Sequence at the I²C-Bus Mode

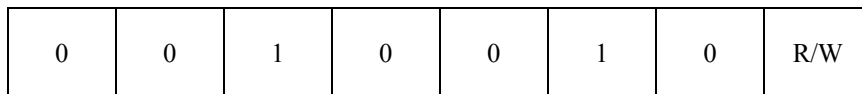

Figure 57. The First Byte

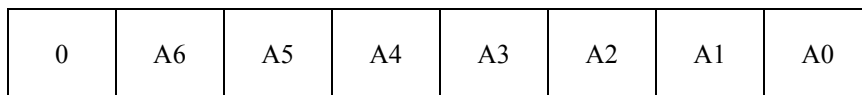

Figure 58. The Second Byte

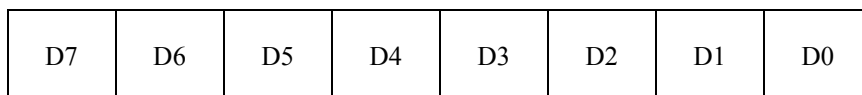

Figure 59. Byte Structure after the second byte

(2)-2. READ Operations

Set the R/W bit = "1" for READ operation of the AK4636. After a transmission of data, if the master generates an acknowledge instead of terminating a write cycle, the internal 7-bit address counter of the AK4636 is incremented by one, and the next data is automatically taken into the next address so that the data can be read from the AK4636. If the address exceeds 4FH prior to generating a stop condition, the address counter will "roll over" to 00H and the data of 00H will be read out.

Note 43. A read operation is available at 00H ~ 0CH, 0EH ~ 11H, 1CH ~ 24H and 27H~30H addresses. When reading the address 0DH, 12H ~ 1BH, 25H ~ 26H and 31H ~ 4FH, the register values are invalid.

The AK4636 supports two basic read operations: CURRENT ADDRESS READ and RANDOM ADDRESS READ.

(2)-2-1. CURRENT ADDRESS READ

The AK4636 contains an internal address counter that maintains the address of the last word accessed, incremented by one. Therefore, if the last access (either a read or write) were to address "n", the next CURRENT READ operation would access data from the address "n+1". After receipt of the slave address with R/W bit "1", the AK4636 generates an acknowledge, transmits 1-byte of data to the address set by the internal address counter and increments the internal address counter by 1. If the master does not generate an acknowledge but instead generates a stop condition, the AK4636 ceases transmission.

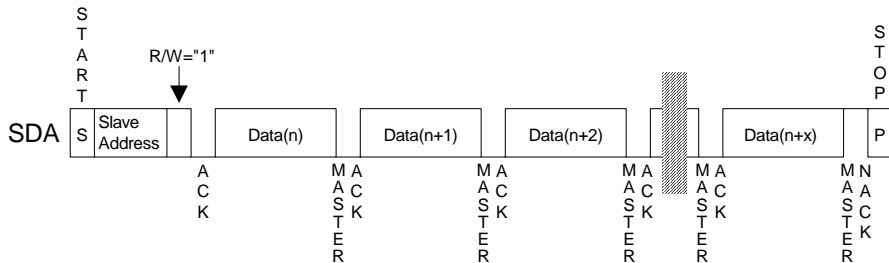

Figure 60. CURRENT ADDRESS READ

(2)-2-2. RANDOM ADDRESS READ

The random read operation allows the master to access any memory location at random. Prior to issuing the slave address with the R/W bit "1", the master must first perform a "dummy" write operation. The master issues a start request, a slave address (R/W bit = "0") and then the register address to read. After the register address is acknowledged, the master immediately reissues the start request and the slave address with the R/W bit set to "1". The AK4636 then generates an acknowledge, 1 byte of data and increments the internal address counter by 1. If the master does not generate an acknowledge but instead generates a stop condition, the AK4636 ceases transmission.

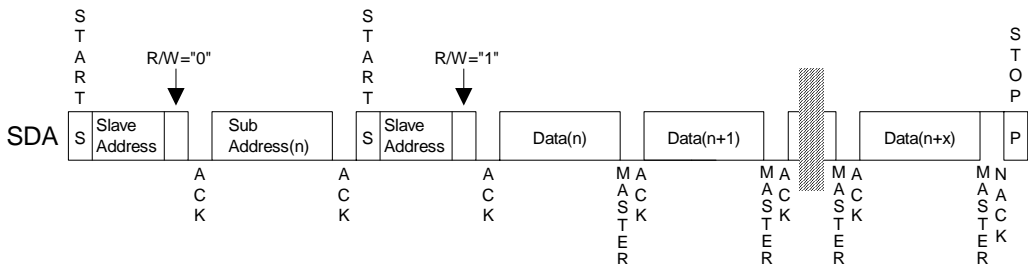

Figure 61. RANDOM ADDRESS READ

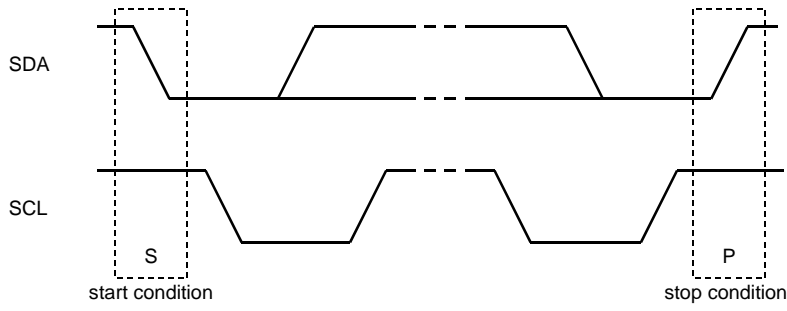

Figure 62. START and STOP Conditions

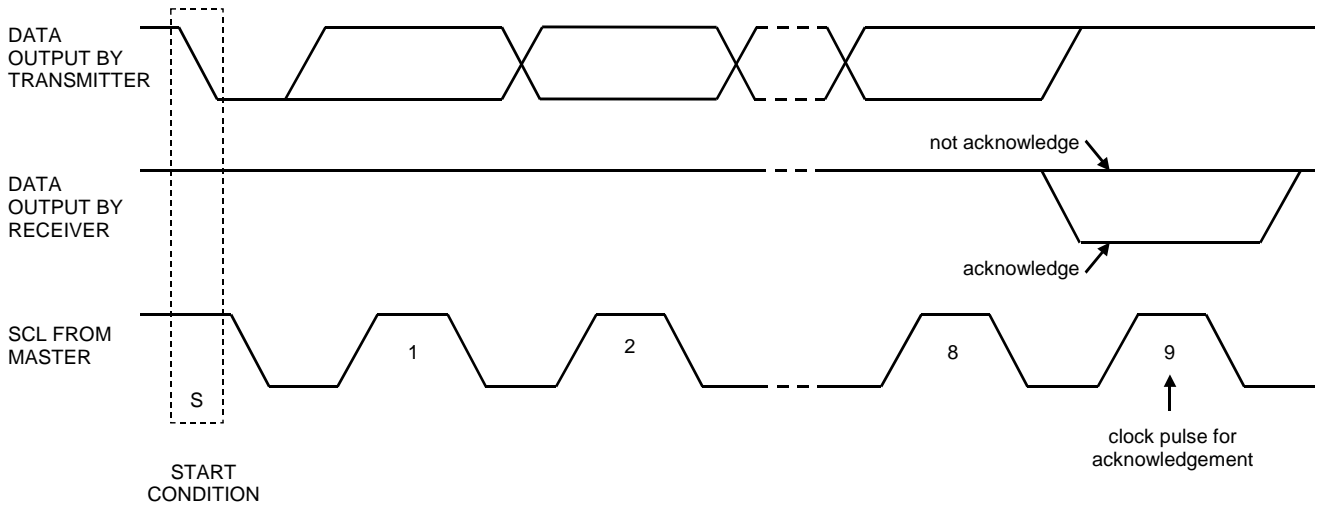

Figure 63. Acknowledge on the I²C-Bus

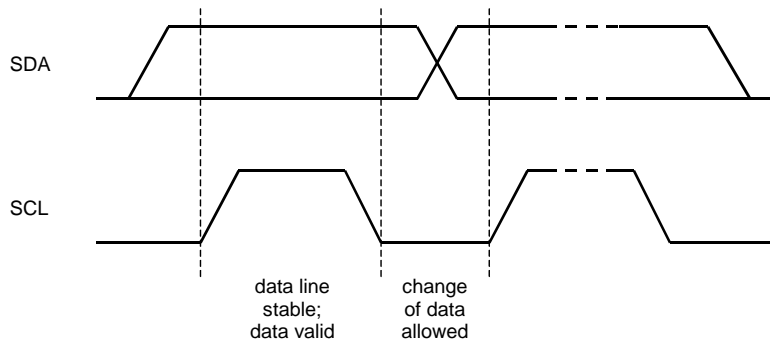

Figure 64. Bit Transfer on the I²C-Bus

■ Register Map

Addr	Register Name	D7	D6	D5	D4	D3	D2	D1	D0
00H	Power Management 1	PMPFIL	PMVCM	PMBP	PMSPK	PMAO	PMDAC	0	PMADC
01H	Power Management 2	PMV	0	0	0	M/S	0	MCKO	PMPLL
02H	Signal Select 1	SPPSN	BEEPS	DACS	DACA	MGAIN3	PMMP	MGAIN2	MGAIN0
03H	Signal Select 2	PFSDO	AOPS	MGAIN1	SPKG1	SPKG0	BEEPA	PFDAC	ADCPF
04H	Mode Control 1	PLL3	PLL2	PLL1	PLL0	BCKO1	BCKO0	DIF1	DIF0
05H	Mode Control 2	ADRST	FCKO	FS3	MSBS	BCKP	FS2	FS1	FS0
06H	Timer Select	0	WTM2	ZTM1	ZTM0	WTM1	WTM0	RFST1	RFST0
07H	ALC Mode Control 1	LFST	ALC2	ALC1	ZELMN	LMAT1	LMAT0	RGAIN0	LMTH0
08H	ALC Mode Control 2	IREF7	IREF6	IREF5	IREF4	IREF3	IREF2	IREF1	IREF0
09H	Input Digital Volume Control	IVOL7	IVOL6	IVOL5	IVOL4	IVOL3	IVOL2	IVOL1	IVOL0
0AH	Output Digital Volume Control	OVOL7	OVOL6	OVOL5	OVOL4	OVOL3	OVOL2	OVOL1	OVOL0
0BH	ALC Mode Control 3	RGAIN1	LMTH1	OREF5	OREF4	OREF3	OREF2	OREF1	OREF0
0CH	Video Mode Control	VDC1	VDC2	0	VGCA4	VGCA3	VGCA2	VGCA1	VGCA0
0DH	ALC LEVEL	VOL7	VOL6	VOL5	VOL4	VOL3	VOL2	VOL1	VOL0
0EH	Signal Select 3	DATT1	DATT0	SMUTE	MDIF	0	0	0	READ
0FH	Digital Volume Control	DVOL7	DVOL6	DVOL5	DVOL4	DVOL3	DVOL2	DVOL1	DVOL0
10H	Signal Select 4	0	LOVL	LP	0	0	0	LIN	0
11H	Digital Filter Select 1	0	0	LPF	HPF	0	0	0	1
12H	Reserved	0	0	0	0	0	0	0	0
13H	Reserved	0	0	0	0	0	0	0	0
14H	Reserved	0	0	0	0	0	0	0	0
15H	Reserved	0	0	0	0	0	0	0	0
16H	Reserved	0	0	0	0	0	0	0	0
17H	Reserved	0	0	0	0	0	0	0	0
18H	Reserved	0	0	0	0	0	0	0	0
19H	Reserved	0	0	0	0	0	0	0	0
1AH	Reserved	0	0	0	0	0	0	0	0
1BH	Reserved	0	0	0	0	0	0	0	0
1CH	HPF Co-efficient 0	F1A7	F1A6	F1A5	F1A4	F1A3	F1A2	F1A1	F1A0
1DH	HPF Co-efficient 1	0	0	F1A13	F1A12	F1A11	F1A10	F1A9	F1A8
1EH	HPF Co-efficient 2	F1B7	F1B6	F1B5	F1B4	F1B3	F1B2	F1B1	F1B0
1FH	HPF Co-efficient 3	0	0	F1B13	F1B12	F1B11	F1B10	F1B9	F1B8
20H	BEEP Frequency	BPCNT	0	0	0	0	0	BPFR1	BPFR0
21H	BEEP ON Time	BPON7	BPON6	BPON5	BPON4	BPON3	BPON2	BPON1	BPON0
22H	BEEP OFF Time	BPOFF7	BPOFF6	BPOFF5	BPOFF4	BPOFF3	BPOFF2	BPOFF1	BPOFF0
23H	BEEP Repeat Count	0	BPTM6	BPTM5	BPTM4	BPTM3	BPTM2	BPTM1	BPTM0
24H	BEEP VOL/Control	BPOUT	0	0	0	0	BPLVL2	BPLVL1	BPLVL0
25H	Reserved	0	0	0	0	0	0	0	0
26H	Reserved	0	0	0	0	0	0	0	0
27H	Digital MIC	0	0	0	PMDM	DCLKE	DMPE	DCLKP	DMIC
28H	BEEP Mode Select	0	0	0	0	0	0	BPM1	BPM0
29H	Noise Suppression 1	0	NSCE	NSTHH1	NSTHH0	NSTHL3	NSTHL2	NSTHL1	NSTHL0
2AH	Noise Suppression 2	0	0	NATT1	NATT0	0	0	NSGAIN1	NSGAIN0
2BH	Noise Suppression 3	NSREF7	NSREF6	NSREF5	NSREF4	NSREF3	NSREF2	NSREF1	NSREF0
2CH	LPF Co-efficient 0	F2A7	F2A6	F2A5	F2A4	F2A3	F2A2	F2A1	F2A0
2DH	LPF Co-efficient 1	0	0	F2A13	F2A12	F2A11	F2A10	F2A9	F2A8
2EH	LPF Co-efficient 2	F2B7	F2B6	F2B5	F2B4	F2B3	F2B2	F2B1	F2B0
2FH	LPF Co-efficient 3	0	0	F2B13	F2B12	F2B11	F2B10	F2B9	F2B8

Addr	Register Name	D7	D6	D5	D4	D3	D2	D1	D0
30H	Digital Filter Select 2	0	0	0	EQ5	EQ4	EQ3	EQ2	EQ1
31H	Reserved	0	0	0	0	0	0	0	0
32H	E1 Co-efficient 0	E1A7	E1A6	E1A5	E1A4	E1A3	E1A2	E1A1	E1A0
33H	E1 Co-efficient 1	E1A15	E1A14	E1A13	E1A12	E1A11	E1A10	E1A9	E1A8
34H	E1 Co-efficient 2	E1B7	E1B6	E1B5	E1B4	E1B3	E1B2	E1B1	E1B0
35H	E1 Co-efficient 3	E1B15	E1B14	E1B13	E1B12	E1B11	E1B10	E1B9	E1B8
36H	E1 Co-efficient 4	E1C7	E1C6	E1C5	E1C4	E1C3	E1C2	E1C1	E1C0
37H	E1 Co-efficient 5	E1C15	E1C14	E1C13	E1C12	E1C11	E1C10	E1C9	E1C8
38H	E2 Co-efficient 0	E2A7	E2A6	E2A5	E2A4	E2A3	E2A2	E2A1	E2A0
39H	E2 Co-efficient 1	E2A15	E2A14	E2A13	E2A12	E2A11	E2A10	E2A9	E2A8
3AH	E2 Co-efficient 2	E2B7	E2B6	E2B5	E2B4	E2B3	E2B2	E2B1	E2B0
3BH	E2 Co-efficient 3	E2B15	E2B14	E2B13	E2B12	E2B11	E2B10	E2B9	E2B8
3CH	E2 Co-efficient 4	E2C7	E2C6	E2C5	E2C4	E2C3	E2C2	E2C1	E2C0
3DH	E2 Co-efficient 5	E2C15	E2C14	E2C13	E2C12	E2C11	E2C10	E2C9	E2C8
3EH	E3 Co-efficient 0	E3A7	E3A6	E3A5	E3A4	E3A3	E3A2	E3A1	E3A0
3FH	E3 Co-efficient 1	E3A15	E3A14	E3A13	E3A12	E3A11	E3A10	E3A9	E3A8
40H	E3 Co-efficient 2	E3B7	E3B6	E3B5	E3B4	E3B3	E3B2	E3B1	E3B0
41H	E3 Co-efficient 3	E3B15	E3B14	E3B13	E3B12	E3B11	E3B10	E3B9	E3B8
42H	E3 Co-efficient 4	E3C7	E3C6	E3C5	E3C4	E3C3	E3C2	E3C1	E3C0
43H	E3 Co-efficient 5	E3C15	E3C14	E3C13	E3C12	E3C11	E3C10	E3C9	E3C8
44H	E4 Co-efficient 0	E4A7	E4A6	E4A5	E4A4	E4A3	E4A2	E4A1	E4A0
45H	E4 Co-efficient 1	E4A15	E4A14	E4A13	E4A12	E4A11	E4A10	E4A9	E4A8
46H	E4 Co-efficient 2	E4B7	E4B6	E4B5	E4B4	E4B3	E4B2	E4B1	E4B0
47H	E4 Co-efficient 3	E4B15	E4B14	E4B13	E4B12	E4B11	E4B10	E4B9	E4B8
48H	E4 Co-efficient 4	E4C7	E4C6	E4C5	E4C4	E4C3	E4C2	E4C1	E4C0
49H	E4 Co-efficient 5	E4C15	E4C14	E4C13	E4C12	E4C11	E4C10	E4C9	E4C8
4AH	E5 Co-efficient 0	E5A7	E5A6	E5A5	E5A4	E5A3	E5A2	E5A1	E5A0
4BH	E5 Co-efficient 1	E5A15	E5A14	E5A13	E5A12	E5A11	E5A10	E5A9	E5A8
4CH	E5 Co-efficient 2	E5B7	E5B6	E5B5	E5B4	E5B3	E5B2	E5B1	E5B0
4DH	E5 Co-efficient 3	E5B15	E5B14	E5B13	E5B12	E5B11	E5B10	E5B9	E5B8
4EH	E5 Co-efficient 4	E5C7	E5C6	E5C5	E5C4	E5C3	E5C2	E5C1	E5C0
4FH	E5 Co-efficient 5	E5C15	E5C14	E5C13	E5C12	E5C11	E5C10	E5C9	E5C8

The PDN pin = "L" resets the registers to their default values.

Note 44. The bits defined as 0 must contain a "0" value.

Note 45. The bits defined as 1 must contain a "1" value.

Note 46. Reading of address 0DH (in I²C-but control mode), 12H ~ 1BH, 25H ~ 26H and 31H ~ 4FH are not possible.

Note 47. 0FH and 0DH are for address read only. Writing access to 0DH and 0FH does not effect the operation.

■ Register Definitions

Addr	Register Name	D7	D6	D5	D4	D3	D2	D1	D0
00H	Power Management 1	PMPFIL	PMVCM	PMBP	PMSPK	PMAO	PMDAC	0	PMADC
	R/W	R/W	R/W	R/W	R/W	R/W	R/W	R	R/W
	Default	0	0	0	0	0	0	0	0

PMADC: ADC Block Power Control

0: Power down (default)

1: Power up

When the PMADC bit changes from “0” to “1”, the initialization cycle ($1059/f_s=133\text{ms}@8\text{kHz}$) starts. After initializing, digital data of the ADC is output.

PMDAC: DAC Block Power Control

0: Power down (default)

1: Power up

PMAO: Mono Line Out Power Control

0: Power down (default)

1: Power up

PMSPK: Speaker Amplifier Power Control

0: Power down (default)

1: Power up

PMBP: BEEP Input Power Management

0: Power down (default)

1: Power up

When PMBP bit = “0”, the path from BEEP to speaker is still connected. Set BEEPS bit = “0” to disconnect this path. The path from BEEP to mono lineout is the same. It can be disconnected by setting BEEPA bit = “0”.

PMVCM: VCOM Block Power Control

0: Power down (default)

1: Power up

PMPFIL: Programmable Filter Block (HPF/ LPF/ 5-Band EQ/ ALC) Power Control

0: Power down (default)

1: Power up

All blocks can be powered-down by writing “0” to the address “00H”, PMPLL, PMV, PMMP, PMDM, DMPE and MCKO bits. In this case, register values are maintained.

PMVCM bit must be “1” when one of blocks is powered-up. PMVCM bit can only be “0” when the address “00H” and all power management bits (PMPLL, PMV, PMMP, PMDM, DMPE and MCKO) are “0”.

When using either ADC, DAC, digital microphone or Programmable Filter (PMADL bit = “1”, PMDM bit = “1”, PMDAC bit = “1” or PMPFIL bit = “1”), clock must be supplied.

Addr	Register Name	D7	D6	D5	D4	D3	D2	D1	D0
01H	Power Management 2	PMV	0	0	0	M/S	0	MCKO	PMPLL
	R/W	R/W	R	R	R	R/W	R	R/W	R/W
	Default	0	0	0	0	0	0	0	0

PMPLL: PLL Block Power Control Select

0: PLL is Power down and External is selected. (default)

1: PLL is Power up and PLL Mode is selected.

MCKO: Master Clock Output Enable

0: "L" Output (default)

1: 256fs Output

M/S: Select Master/ Slave Mode

0: Slave Mode (default)

1: Master Mode

PMV: Video Block Power Control

0: Power down (default)

1: Power up

Addr	Register Name	D7	D6	D5	D4	D3	D2	D1	D0
02H	Signal Select 1	SPPSN	BEEPS	DACS	DACA	MGAIN3	PMMP	MGAIN2	MGAIN0
	R/W	R/W	R/W	R/W	R/W	R/W	R/W	R/W	R/W
	Default	0	0	0	0	0	0	0	1

MGAIN3-2, MGAIN0: MIC-amp Gain control ([Table 20](#))

MGAIN1 bit is located at D5 bit of 03H. Default: "0001" (+20.0dB)

PMMP: MPI pin Power Control

0: OFF (default)

1: ON

DACA: Switch Control from DAC to mono line amp

0: OFF (default)

1: ON

When PMAO bit is "1", DACA bit is enabled. When PMAO bit is "0", the AOUT pin goes VSS1.

DACS: Switch Control from DAC to Speaker-Amp

0: OFF (default)

1: ON

When DACS bit is "1", DAC output signal is input to Speaker-Amp.

BEEPS: Switch Control from MIN pin to Speaker-Amp

0: OFF (default)

1: ON

When BEEPS bit is "1", mono signal is input to Speaker-Amp.

SPPSN: Speaker-Amp Power-Save Mode

0: Power-Save Mode (default)

1: Normal Operation

When SPPSN bit is "0", Speaker-Amp is on power-save mode. In this mode, the SPP pin goes to Hi-Z and outputs SVDD/2 voltage. When PMSPK bit = "1", SPPSN bit is enabled. After the PDN pin is set to "L", Speaker-Amp is in power-down mode since PMSPK bit is "0".

Addr	Register Name	D7	D6	D5	D4	D3	D2	D1	D0
03H	Signal Select 2	PFSDO	AOPS	MGAIN1	SPKG1	SPKG0	BEEPA	PFDAC	ADCPF
	R/W	R/W	R/W	R/W	R/W	R/W	R/W	R/W	R/W
	Default	1	0	0	0	0	0	0	0

ADCPF: Select input signal to Programmable Filter/ALC.

0: SDTI

1: Output of ADC (default)

PFDAC: Select input signal to DAC.

0: SDTI (default)

1: Output of Programmable Filter/ALC

BEEPA: Switch Control of BEEP signal to Mono-Amp

0: OFF (default)

1: ON

When PMAO bit="1", this bit is enabled. When PMAO bit="0", AOUT pin goes to VSS1.

SPKG1-0: Select Speaker-Amp Output Gain (Table 55)

Default: "00"

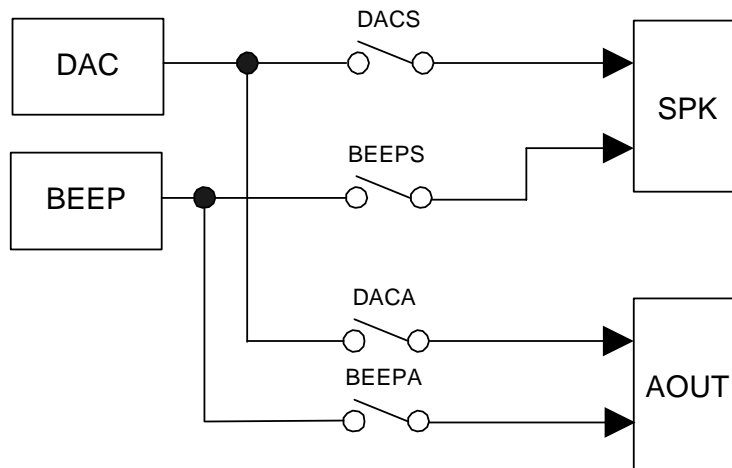

Figure 65. Speaker and Mono Lineout-Amps switch control

MGAIN1: Mic-Amplifier Gain Control (Table 20)

MGAIN3-2 and MGAIN0 bits are D3, D1 and D0 of 02H. Default: "0001" (+20.0dB)

AOPS: Mono Line Output Power-Save Mode

0: Normal Operation (default)

1: Power-Save Mode

Power-save mode is enable at AOPS bit = "1". POP noise at power-up/down can be reduced by changing at PMAO bit = "1". (Figure 52)

PFSDO: Select of signal from SDTO

0: Output of ADC (1st - HPF)

1: Output of Programmable Filter/ALC (default)

Addr	Register Name	D7	D6	D5	D4	D3	D2	D1	D0
04H	Mode Control 1	PLL3	PLL2	PLL1	PLL0	BCKO1	BCKO0	DIF1	DIF0
	R/W	R/W	R/W	R/W	R/W	R/W	R/W	R/W	R/W
	Default	0	0	0	0	0	1	1	0

DIF1-0: Audio Interface Format (Table 16)

Default: "10" (MSB First)

BCKO1-0: Select BICK output frequency at Master Mode (Table 9)

Default: "01" (32fs)

PLL3-0: Select input frequency at PLL mode (Table 4)

Default: "0000" (FCK pin)

Addr	Register Name	D7	D6	D5	D4	D3	D2	D1	D0
05H	Mode Control 2	ADRST	FCKO	FS3	MSBS	BCKP	FS2	FS1	FS0
	R/W	R/W	R/W	R/W	R/W	R/W	R/W	R/W	R/W
	Default	0	0	0	0	0	0	0	0

FS3-0: Setting of Sampling Frequency (Table 5 and Table 6) and MCKI Frequency (Table 11)

These bits select sampling frequency at PLL mode and MCKI frequency at EXT mode.

Default: "0000"

BCKP, MSBS: "00" (default) (Table 17)

FCKO: Select FCK output frequency at Master Mode (Table 10)

Default: "0"

ADRST: Initialization cycle setting of ADC

0: 1059/fs (default)

1: 291/fs

Addr	Register Name	D7	D6	D5	D4	D3	D2	D1	D0
06H	Timer Select	0	WTM2	ZTM1	ZTM0	WTM1	WTM0	RFST1	RFST0
	R/W	R	R/W	R/W	R/W	R/W	R/W	R/W	R/W
	Default	0	0	0	0	0	0	0	0

WTM2-0: ALC1 Recovery Waiting Period ([Table 30](#))

A period of recovery operation when any limiter operation does not occur during the ALC1 operation.
Default is "000".

ZTM1-0: ALC1, ALC2, IVOL and OVOL Zero crossing timeout Period ([Table 29](#))

The gain is changed by the manual volume controlling (ALC off) or the recovery operation (ALC on) only at Zero crossing or timeout. The default value is "00".

RFST1-0 : ALC First recovery Speed ([Table 34](#))

Default: "00" (4times)

Addr	Register Name	D7	D6	D5	D4	D3	D2	D1	D0
07H	ALC Mode Control 1	LFST	ALC2	ALC1	ZELMN	LMAT1	LMAT0	RGAIN0	LMTH0
	R/W	R/W	R/W	R/W	R/W	R/W	R/W	R/W	R/W
	Default	0	0	0	0	0	0	0	1

LMTH1-0: ALC Limiter Detection Level / Recovery Waiting Counter Reset Level ([Table 27](#))

LMTH1 bit is located at D6 bit of 0BH. Default: "01"

RGAIN1-0: ALC Recovery GAIN Step ([Table 31](#))

RGAIN1 bit is located at D7 bit of 0BH. Default: "00"

LMAT1-0: ALC Limiter ATT Step ([Table 28](#))

Default: "00"

ZELMN: Zero crossing detection enable at ALC Limiter operation

0: Enable (default)

1: Disable

ALC1: ALC of recoding path Enable

0: Disable (default)

1: Enable

ALC2: ALC2 of playback path Enable

0: Disable (default)

1: Enable

LFST: Limiter function of ALC when the output is bigger than Fs.

0: The volume value is changed at zero crossing or timeout. (default)

1: When output of ALC is bigger than FS, VOL value is changed instantly.

Addr	Register Name	D7	D6	D5	D4	D3	D2	D1	D0
08H	ALC Mode Control 2	IREF7	IREF6	IREF5	IREF4	IREF3	IREF2	IREF1	IREF0
	R/W	R/W	R/W	R/W	R/W	R/W	R/W	R/W	R/W
	Default	1	1	0	0	0	1	0	1

IREF7-0: Reference value at ALC Recovery operation for recoding. (0.375dB step, 242 Level) (Table 32)
Default: "C5H" (+19.5dB)

Addr	Register Name	D7	D6	D5	D4	D3	D2	D1	D0
09H	Input Digital Volume Control	IVOL7	IVOL6	IVOL5	IVOL4	IVOL3	IVOL2	IVOL1	IVOL0
	R/W	R/W	R/W	R/W	R/W	R/W	R/W	R/W	R/W
	Default	1	0	0	1	0	0	0	1

IVOL7-0: Input Digital Volume; 0.375dB step, 242 Level (Table 22)
Default: "91H" (0.0dB)

Addr	Register Name	D7	D6	D5	D4	D3	D2	D1	D0
0AH	Digital Volume Control	OVOL7	OVOL6	OVOL5	OVOL4	OVOL3	OVOL2	OVOL1	OVOL0
	R/W	R/W	R/W	R/W	R/W	R/W	R/W	R/W	R/W
	Default	1	0	0	1	0	0	0	1

OVOL7-0: Output Digital Volume; 0.375dB step, 242 Level (Table 23)
Default: "91H" (0.0dB)

Addr	Register Name	D7	D6	D5	D4	D3	D2	D1	D0
0BH	ALC Mode Control 3	RGAIN1	LMTH1	OREF5	OREF4	OREF3	OREF2	OREF1	OREF0
	R/W	R/W	R/W	R/W	R/W	R/W	R/W	R/W	R/W
	Default	0	0	1	0	1	0	0	0

OREF5-0: Reference value at ALC Recovery operation for playback. 1.5dB step, 60 Level (Table 33)
Default: "28H" (+6.0dB)

LMTH1-0: ALC Limiter Detection Level / Recovery Waiting Counter Reset Level (Table 27)
LMTH0 bit is located at D0 bit of 07H. Default: "01"

RGAIN1-0: ALC Recovery GAIN Step (Table 31)
RGAIN0 bit is located at D1 bit of 07H. Default: "00"

Addr	Register Name	D7	D6	D5	D4	D3	D2	D1	D0
0CH	Video Mode Control	0	0	0	VGCA4	VGCA3	VGCA2	VGCA1	VGCA0
	R/W	R	R	R	R/W	R/W	R/W	R/W	R/W
	Default	0	0	0	0	0	0	1	0

VGCA4-0: Gain Control of Video output (Table 56)
Default: "00010"

Addr	Register Name	D7	D6	D5	D4	D3	D2	D1	D0
0DH	Input Digital Volume Control	VOL7	VOL6	VOL5	VOL4	VOL3	VOL2	VOL1	VOL0
	R/W	R	R	R	R	R	R	R	R
	Default	-	-	-	-	-	-	-	-

VOL7-0: The current volume of ALC; 0.375dB step, 242 Level, Read only (Table 35)

Note 48. In 3-wire serial control mode. Register values are invalid when reading the address 0DH in I²C bus control mode.

Addr	Register Name	D7	D6	D5	D4	D3	D2	D1	D0
0EH	Mode Control 3	DATT1	DATT0	SMUTE	MDIF	0	0	0	READ
	R/W	R/W	R/W	R/W	R/W	R	R	R	R/W
	Default	0	0	0	0	0	0	0	0

READ: Read function Enable

0: Disable (default)

1: Enable

MDIF: Single-ended / Full-differential Input Select

0: Single-ended input (MIC pin or LIN pin: Default)

1: Full-differential input (MIC/MICP and LIN/MICN pins)

SMUTE: Soft Mute Control

0: Normal Operation (default)

1: DAC outputs soft-muted

DATT1-0: Output Digital Volume2; 6dB step, 4 Level (Table 24)

Default: "00H" (0.0dB)

Addr	Register Name	D7	D6	D5	D4	D3	D2	D1	D0
0FH	Thermal Shutdown	DVOL7	DVOL6	DVOL5	DVOL4	DVOL3	DVOL2	DVOL1	DVOL0
	R/W	R/W	R/W	R/W	R/W	R/W	R/W	R/W	R/W
	Default	1	1	1	1	0	1	0	1

DVOL7-0: Output Digital Volume3; Linear step (Table 25, Table 26)

Default: "F5H" (0dB)

Addr	Register Name	D7	D6	D5	D4	D3	D2	D1	D0
10H	Signal Select 4	0	LOVL	LP	0	0	0	LIN	0
	R/W	R	R/W	R/W	R	R	R	R/W	R
	Default	0	0	0	0	0	0	0	0

LIN: Select Input data of ADC

0: MIC pin (default)

1: LIN pin

LP: Low Power Mode

0: Normal Mode (default)

1: Low Power Mode: It can be operated by fs=22.05kHz or less.

LOVL: Lineout Gain Setting

0: 0dB(default)

1: +3dB

Addr	Register Name	D7	D6	D5	D4	D3	D2	D1	D0
11H	Digital Filter Select 1	0	0	LPF	HPF	0	0	0	1
	R/W	R	R	R/W	R/W	R	R	R	R
	Default	0	0	0	1	0	0	0	1

HPF: HPF2 Enable

0: Disable

1: Enable (default)

When HPF bit is “0”, HPF2 block is bypassed (0dB).

When HPF bit is “1”, F1A13-0, F1B13-0 bits are enabled.

LPF: LPF Coefficient Setting Enable

0: Disable (default)

1: Enable

When LPF bit is “0”, LPF block is bypassed (0dB).

When LPF bit is “1”, F2A13-0, F2B13-0 bits are enabled.

Addr	Register Name	D7	D6	D5	D4	D3	D2	D1	D0
1CH	HPF Co-efficient 0	F1A7	F1A6	F1A5	F1A4	F1A3	F1A2	F1A1	F1A0
1DH	HPF Co-efficient 1	0	0	F1A13	F1A12	F1A11	F1A10	F1A9	F1A8
1EH	HPF Co-efficient 2	F1B7	F1B6	F1B5	F1B4	F1B3	F1B2	F1B1	F1B0
1FH	HPF Co-efficient 3	0	0	F1B13	F1B12	F1B11	F1B10	F1B9	F1B8
	R/W	W	W	W	W	W	W	W	W
	Default	F1A13-0 bits = 0x1F16, F1B13-0 bits = 0x1E2B							

F1A13-0, F1B13-0: FIL1 (Wind-noise Reduction Filter) Coefficient (14bit x 2)

Default: F1A13-0 bits = 0x1F16, F1B13-0 bits = 0x1E2B

$f_c = 75\text{Hz}@f_s = 8\text{kHz}$, $150\text{Hz}@f_s = 16\text{kHz}$

Addr	Register Name	D7	D6	D5	D4	D3	D2	D1	D0
20H	BEEP Frequency	BPCNT	0	0	0	0	0	BPFR1	BPFR0
	R/W	R/W	R	R	R	R	R	R/W	R/W
	Default	0	0	0	0	0	0	0	0

BPFR1-0: BEEP Signal Output Frequency Setting ([Table 47](#), [Table 48](#), [Table 49](#))

Default: “00H”

BPCNT: BEEP Signal Output Mode Setting

0: Once Output Mode. (default)

1: Continuous Mode

In continuous mode, the BEEP signal is output while BPCNT bit is “1”.

In once output mode, the BEEP signal is output by only the frequency set with BPTM6-0 bits.

Addr	Register Name	D7	D6	D5	D4	D3	D2	D1	D0
21H	BEEP ON Time	BPON7	BPON6	BPON5	BPON4	BPON3	BPON2	BPON1	BPON0
	R/W	R/W	R/W	R/W	R/W	R/W	R/W	R/W	R/W
	Default	0	0	0	0	0	0	0	0

BPON7-0: Setting ON-time of BEEP signal output (Table 50)

Default: "00H"

Addr	Register Name	D7	D6	D5	D4	D3	D2	D1	D0
22H	BEEP OFF Time	BPOFF7	BPOFF6	BPOFF5	BPOFF4	BPOFF3	BPOFF2	BPOFF1	BPOFF0
	R/W	R/W	R/W	R/W	R/W	R/W	R/W	R/W	R/W
	Default	0	0	0	0	0	0	0	0

BPOFF7-0: Setting OFF-time of BEEP signal output (Table 51)

Default: "00H"

Addr	Register Name	D7	D6	D5	D4	D3	D2	D1	D0
23H	BEEP Repeat Count	0	BPTM6	BPTM5	BPTM4	BPTM3	BPTM2	BPTM1	BPTM0
	R/W	R	R/W	R/W	R/W	R/W	R/W	R/W	R/W
	Default	0	0	0	0	0	0	0	0

BPTM6-0: Setting the number of times that BEEP signal repeats (Table 52)

Default: "00H"

Addr	Register Name	D7	D6	D5	D4	D3	D2	D1	D0
24H	BEEP VOL/Control	BPOUT	0	0	0	0	BPLVL2	BPLVL1	BPLVL0
	R/W	R/W	R	R	R	R	R/W	R/W	R/W
	Default	0	0	0	0	0	0	0	0

BPLVL2-0: Setting Output Level of BEEP signal (Table 53)

Default: "0H" (0dB)

BPOUT: BEEP Signal Control

0: OFF (default)

1: ON

At the time of BPCNT = "0", when BPOUT bit is "1", the beep signal starts outputting. The Beep signal stops after the number of times that is set by BPTM6-0 bit, and BPOUT bit is set to "0" automatically.

Addr	Register Name	D7	D6	D5	D4	D3	D2	D1	D0
27H	Digital MIC	0	0	0	PMDM	DCLKE	DMPE	DCLKP	DMIC
	R/W	R	R	R	R/W	R/W	R/W	R/W	R/W
	Default	0	0	0	0	0	0	1	0

DMIC: Digital Microphone Connection Select

0: Analog MIC (set to MIC/LIN pin or MICP/MICN pin: Default)

1: Digital MIC (set to DMDAT pin/ DMCLK pin)

DCLKP: Data Latching Edge Select

0: Data is latched on the DMCLK rising edge (“↑”). (default)

1: Data is latched on the DMCLK falling edge (“↓”).

DMPE: Digital Microphone Power Supply

0: Externally (the same supply as AVDD) (default)

1: DMP pin

DCLKE: DMCLK pin Output Clock Control

0: “L” Output (default)

1: 64fs Output

PMDM: Digital Microphone Power Management

0: OFF (default)

1: ON

Addr	Register Name	D7	D6	D5	D4	D3	D2	D1	D0
28H	BEEP Mode Select	0	0	0	0	0	0	BPM1	BPM0
	R/W	R	R	R	R	R	R	R/W	R/W
	Default	0	0	0	0	0	0	0	0

BPM1-0: BEEP Mode Setting ([Table 43](#))

Default: “00”: Disable

Addr	Register Name	D7	D6	D5	D4	D3	D2	D1	D0
29H	Noise Suppression 1	0	NSCE	NSTHH1	NSTHH0	NSTHL3	NSTHL2	NSTHL1	NSTHL0
	R/W	R	R/W	R/W	R/W	R/W	R/W	R/W	R/W
	Default	0	0	0	1	0	0	0	0

NSTHL3-0: Noise Suppression Threshold Low Level Setting ([Table 38](#))

Default: “0000” (-81dBFS)

NSTHH1-0: Noise Suppression Threshold High Level Setting([Table 40](#))

Default: “01” (NSTHL3-0 bits + 6dB)

NSCE: Noise Suppression Enable

0: Disable (default)

1: Enable

Addr	Register Name	D7	D6	D5	D4	D3	D2	D1	D0
2AH	Noise Suppression 2	0	0	NATT1	NATT0	0	0	NSGAIN1	NSGAIN0
	R/W	R	R	R/W	R/W	R	R	R/W	R/W
	Default	0	0	0	1	0	0	0	1

NSGAIN1-0: ALC First Recovery Speed Setting after Noise Suppression ([Table 41](#))

Default: “01” (12 times)

NATT1-0: Noise Attenuate Step Setting ([Table 39](#))

Default: “01” (1/2 step)

Addr	Register Name	D7	D6	D5	D4	D3	D2	D1	D0
2BH	Noise Suppression 3	NSREF7	NSREF6	NSREF5	NSREF4	NSREF3	NSREF2	NSREF1	NSREF0
	R/W	R/W	R/W	R/W	R/W	R/W	R/W	R/W	R/W
	Default	1	0	0	1	0	0	0	1

NSREF7-0: Reference Level Setting at Noise Suppression
 0.375dB step, 242 Level (Table 42)
 Default: "91H" (0dB)

Addr	Register Name	D7	D6	D5	D4	D3	D2	D1	D0
2CH	LPF Co-efficient 0	F2A7	F2A6	F2A5	F2A4	F2A3	F2A2	F2A1	F2A0
2DH	LPF Co-efficient 1	0	0	F2A13	F2A12	F2A11	F2A10	F2A9	F2A8
2EH	LPF Co-efficient 2	F2B7	F2B6	F2B5	F2B4	F2B3	F2B2	F2B1	F2B0
2FH	LPF Co-efficient 3	0	0	F2B13	F2B12	F2B11	F2B10	F2B9	F2B8
	R/W	W	W	W	W	W	W	W	W
	Default	0	0	0	0	0	0	0	0

F2A13-0, F2B13-0: LPF Coefficient (14bit x 2)
 Default: "0000"

Addr	Register Name	D7	D6	D5	D4	D3	D2	D1	D0
30H	Digital Filter Select 2	0	0	0	EQ5	EQ4	EQ3	EQ2	EQ1
	R/W	R	R	R	R/W	R/W	R/W	R/W	R/W
	Default	0	0	0	0	0	0	0	0

EQ1: Equalizer 1 Coefficient Setting Enable

0: Disable (default)

1: Enable

When EQ1 bit is "1", E1A15-0, E1B15-0, E1C15-0 bits are enabled. When EQ1 bit is "0", EQ1 block is through (0dB).

EQ2: Equalizer 2 Coefficient Setting Enable

0: Disable (default)

1: Enable

When EQ2 bit is "1", E2A15-0, E2B15-0, E2C15-0 bits are enabled. When EQ2 bit is "0", EQ2 block is through (0dB).

EQ3: Equalizer 3 Coefficient Setting Enable

0: Disable (default)

1: Enable

When EQ3 bit is "1", E3A15-0, E3B15-0, E3C15-0 bits are enabled. When EQ3bit is "0", EQ3 block is through (0dB).

EQ4: Equalizer 4 Coefficient Setting Enable

0: Disable (default)

1: Enable

When EQ4 bit is "1", E4A15-0, E4B15-0, E4C15-0 bits are enabled. When EQ4 bit is "0", EQ4 block is through (0dB).

EQ5: Equalizer 5 Coefficient Setting Enable

0: Disable (default)

1: Enable

When EQ5 bit is "1", E5A15-0, E5B15-0, E5C15-0 bits are enabled. When EQ5 bit is "0", EQ5 block is through (0dB).

Addr	Register Name	D7	D6	D5	D4	D3	D2	D1	D0
32H	E1 Co-efficient 0	E1A7	E1A6	E1A5	E1A4	E1A3	E1A2	E1A1	E1A0
33H	E1 Co-efficient 1	E1A15	E1A14	E1A13	E1A12	E1A11	E1A10	E1A9	E1A8
34H	E1 Co-efficient 2	E1B7	E1B6	E1B5	E1B4	E1B3	E1B2	E1B1	E1B0
35H	E1 Co-efficient 3	E1B15	E1B14	E1B13	E1B12	E1B11	E1B10	E1B9	E1B8
36H	E1 Co-efficient 4	E1C7	E1C6	E1C5	E1C4	E1C3	E1C2	E1C1	E1C0
37H	E1 Co-efficient 5	E1C15	E1C14	E1C13	E1C12	E1C11	E1C10	E1C9	E1C8
38H	E2 Co-efficient 0	E2A7	E2A6	E2A5	E2A4	E2A3	E2A2	E2A1	E2A0
39H	E2 Co-efficient 1	E2A15	E2A14	E2A13	E2A12	E2A11	E2A10	E2A9	E2A8
3AH	E2 Co-efficient 2	E2B7	E2B6	E2B5	E2B4	E2B3	E2B2	E2B1	E2B0
3BH	E2 Co-efficient 3	E2B15	E2B14	E2B13	E2B12	E2B11	E2B10	E2B9	E2B8
3CH	E2 Co-efficient 4	E2C7	E2C6	E2C5	E2C4	E2C3	E2C2	E2C1	E2C0
3DH	E2 Co-efficient 5	E2C15	E2C14	E2C13	E2C12	E2C11	E2C10	E2C9	E2C8
3EH	E3 Co-efficient 0	E3A7	E3A6	E3A5	E3A4	E3A3	E3A2	E3A1	E3A0
3FH	E3 Co-efficient 1	E3A15	E3A14	E3A13	E3A12	E3A11	E3A10	E3A9	E3A8
40H	E3 Co-efficient 2	E3B7	E3B6	E3B5	E3B4	E3B3	E3B2	E3B1	E3B0
41H	E3 Co-efficient 3	E3B15	E3B14	E3B13	E3B12	E3B11	E3B10	E3B9	E3B8
42H	E3 Co-efficient 4	E3C7	E3C6	E3C5	E3C4	E3C3	E3C2	E3C1	E3C0
43H	E3 Co-efficient 5	E3C15	E3C14	E3C13	E3C12	E3C11	E3C10	E3C9	E3C8
44H	E4 Co-efficient 0	E4A7	E4A6	E4A5	E4A4	E4A3	E4A2	E4A1	E4A0
45H	E4 Co-efficient 1	E4A15	E4A14	E4A13	E4A12	E4A11	E4A10	E4A9	E4A8
46H	E4 Co-efficient 2	E4B7	E4B6	E4B5	E4B4	E4B3	E4B2	E4B1	E4B0
47H	E4 Co-efficient 3	E4B15	E4B14	E4B13	E4B12	E4B11	E4B10	E4B9	E4B8
48H	E4 Co-efficient 4	E4C7	E4C6	E4C5	E4C4	E4C3	E4C2	E4C1	E4C0
49H	E4 Co-efficient 5	E4C15	E4C14	E4C13	E4C12	E4C11	E4C10	E4C9	E4C8
4AH	E5 Co-efficient 0	E5A7	E5A6	E5A5	E5A4	E5A3	E5A2	E5A1	E5A0
4BH	E5 Co-efficient 1	E5A15	E5A14	E5A13	E5A12	E5A11	E5A10	E5A9	E5A8
4CH	E5 Co-efficient 2	E5B7	E5B6	E5B5	E5B4	E5B3	E5B2	E5B1	E5B0
4DH	E5 Co-efficient 3	E5B15	E5B14	E5B13	E5B12	E5B11	E5B10	E5B9	E5B8
4EH	E5 Co-efficient 4	E5C7	E5C6	E5C5	E5C4	E5C3	E5C2	E5C1	E5C0
4FH	E5 Co-efficient 5	E5C15	E5C14	E5C13	E5C12	E5C11	E5C10	E5C9	E5C8
R/W		W	W	W	W	W	W	W	W
Default		0	0	0	0	0	0	0	0

E1A15-0, E1B15-0, E1C15-0: Equalizer 1 Coefficient (16bit x3)
Default: "0000H"

E2A15-0, E2B15-0, E2C15-0: Equalizer 2 Coefficient (16bit x3)
Default: "0000H"

E3A15-0, E3B15-0, E3C15-0: Equalizer 3 Coefficient (16bit x3)
Default: "0000H"

E4A15-0, E4B15-0, E4C15-0: Equalizer 4 Coefficient (16bit x3)
Default: "0000H"

E5A15-0, E5B15-0, E5C15-0: Equalizer 5 Coefficient (16bit x3)
Default: "0000H"

SYSTEM DESIGN

Figure 66 ~ Figure 69 show the system connection diagram. The evaluation board [AKD4636] demonstrates the optimum layout, power supply arrangements and measurement results.

< MIC Single-end Input >

AK4636ECB

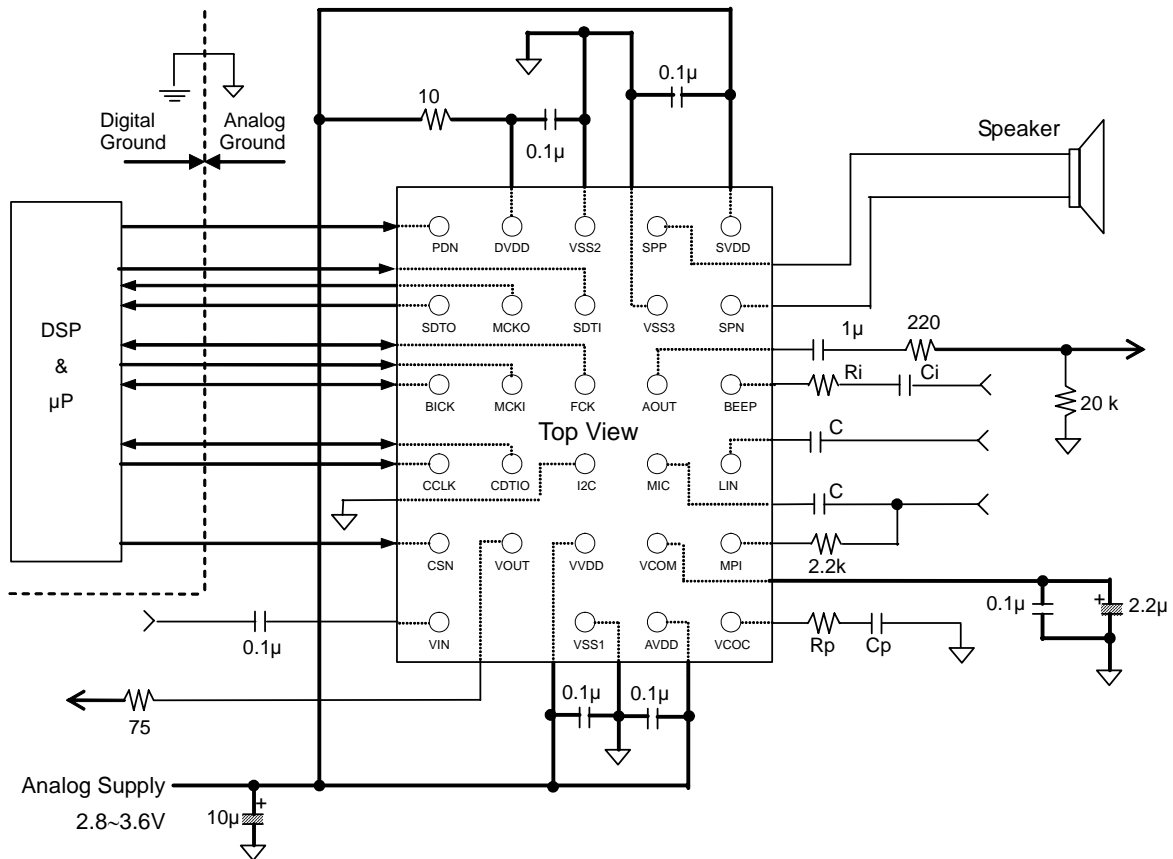

Figure 66. Typical Connection Diagram (3-wire Mode, I2C pin = "L", BPM1-0 bits = "10")

Notes:

- VSS1, VSS2 and VSS3 of the AK4636 should be distributed separately from the ground of external controllers.
- All digital input pins except pull-down pin should not be left floating.
- In EXT mode (PMPLL bit = "0"), Rp and Cp of the VCOC pin can be open.
- In PLL mode (PMPLL bit = "1"), Rp and Cp of the VCOC pin should be connected as shown in Table 4.
- When the AK4636 is used at master mode, FCK and BICK pins are floating before M/S bit is changed to "1". Therefore, a pull-up resistor with around 100Ω should be connected to FCK and BICK pins of the AK4636.
- When AVDD, DVDD, SVDD and VVDD were distributed, AVDD = 2.6 ~ 3.6V, DVDD = 1.6 ~ 3.6V, SVDD = 2.6 ~ 3.6V, VVDD = 2.8 ~ 3.6V.
- 1st-order HPF consists of the input impedance of the LIN pin and MIN pin (R = typ 30 kΩ) and the LIN, MIN pin capacitors "C" before MIC-Amp. The cut-off frequency of the HPF (fs) is calculated by the following formula.

$$f_c = 1 / (2\pi R C)$$

AK4636EN

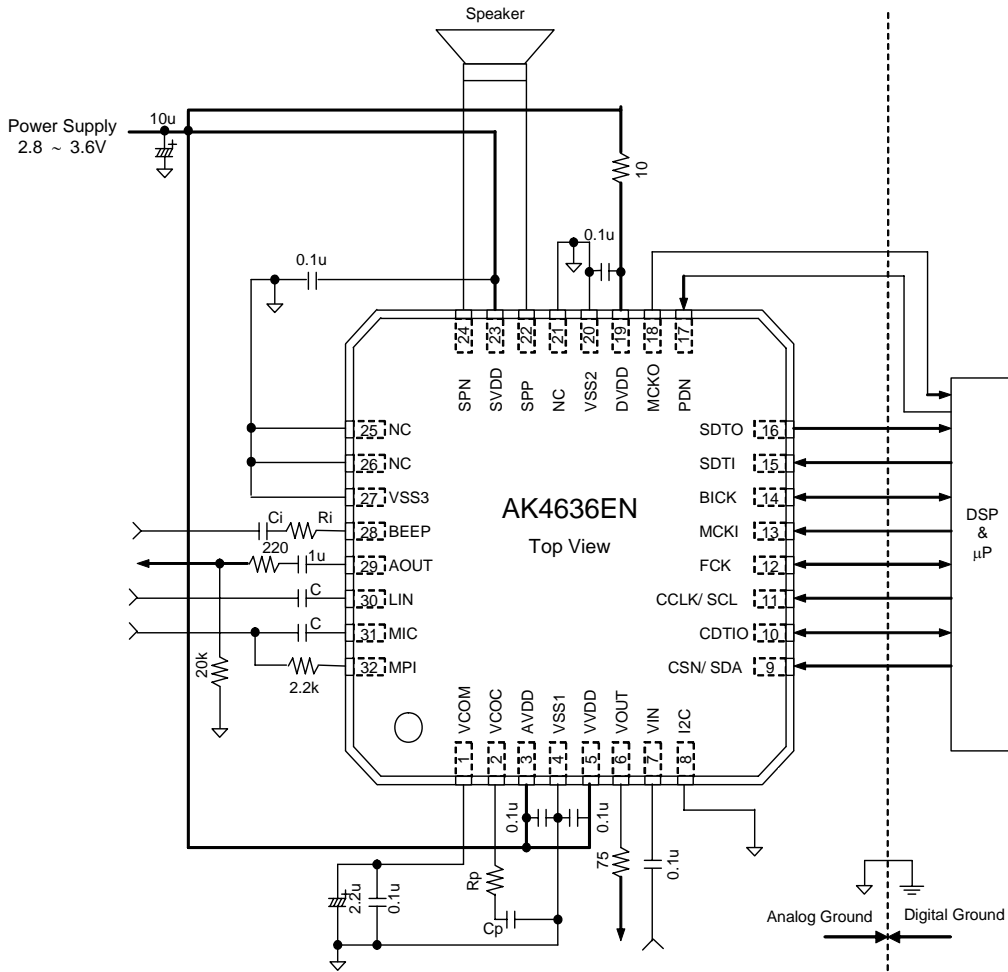

Figure 67. Typical Connection Diagram (3-wire Mode, I2C pin = "L", BPM1-0 bits = "10")

Notes:

- VSS1, VSS2 and VSS3 of the AK4636 should be distributed separately from the ground of external controllers.
- All digital input pins except pull-down pin should not be left floating.
- In EXT mode (PMPLL bit = "0"), Rp and Cp of the VCOC pin can be open.
- In PLL mode (PMPLL bit = "1"), Rp and Cp of the VCOC pin should be connected as shown in Table 4.
- When the AK4636 is used at master mode, FCK and BICK pins are floating before M/S bit is changed to "1". Therefore, a pull-up resistor with around 100Ω should be connected to FCK and BICK pins of the AK4636.
- When AVDD, DVDD, SVDD and VVDD were distributed, AVDD = 2.6 ~ 3.6V, DVDD = 1.6 ~ 3.6V, SVDD = 2.6 ~ 3.6V, VVDD = 2.8 ~ 3.6V.
- 1st-order HPF consists of the input impedance of the LIN pin and MIN pin (R = typ 30 kΩ) and the LIN, MIN pin capacitors "C" before MIC-Amp. The cut-off frequency of the HPF(fs) is calculated by the following formula.

$$f_c = 1 / (2\pi R C)$$

AK4636EN

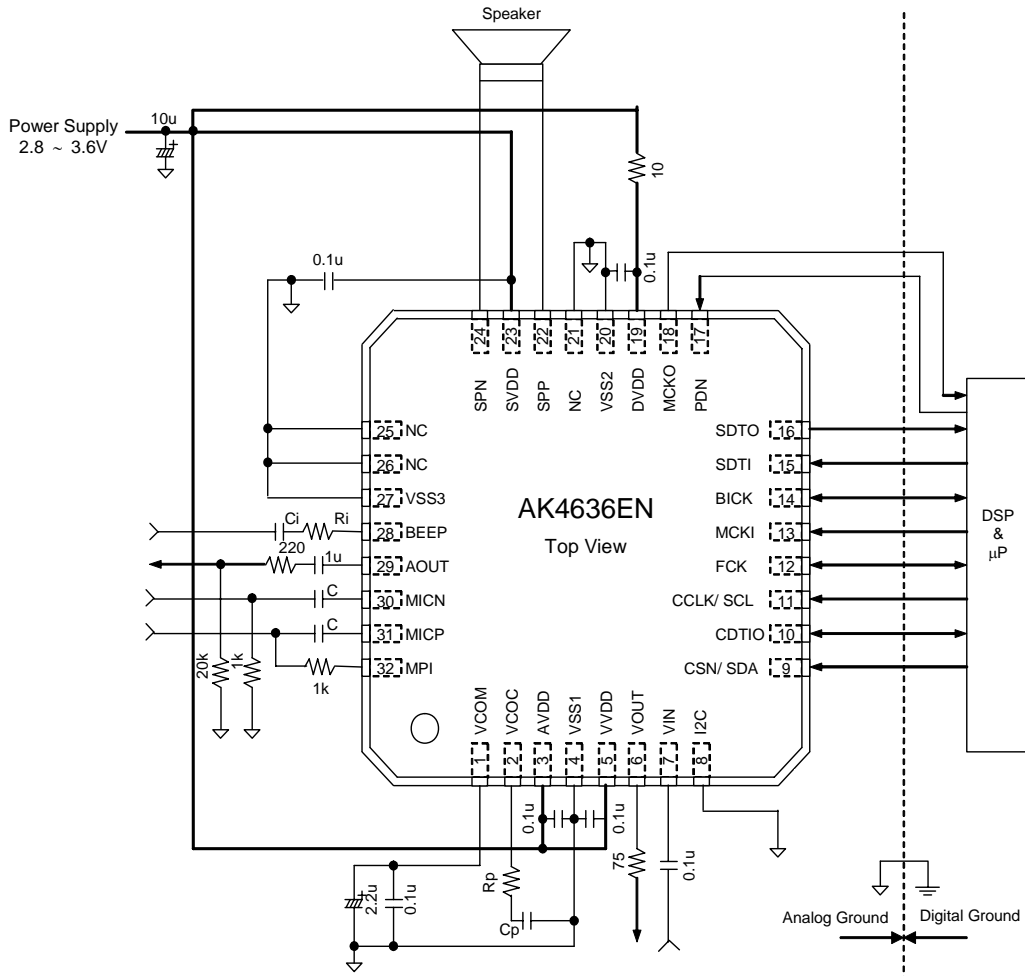

Figure 69. Typical Connection Diagram (3-wire Mode, I2C pin = "L", BPM1-0 bits = "10")

Notes:

- VSS1, VSS2 and VSS3 of the AK4636 should be distributed separately from the ground of external controllers.
- All digital input pins except pull-down pin should not be left floating.
- In EXT mode (PMPLL bit = "0"), Rp and Cp of the VCOC pin can be open.
- In PLL mode (PMPLL bit = "1"), Rp and Cp of the VCOC pin should be connected as shown in Table 4.
- When the AK4636 is used at master mode, FCK and BICK pins are floating before M/S bit is changed to "1". Therefore, a pull-up resistor with around 100Ω should be connected to FCK and BICK pins of the AK4636.
- When AVDD, DVDD, SVDD and VVDD were distributed, AVDD = 2.6 ~ 3.6V, DVDD = 1.6 ~ 3.6V, SVDD = 2.6 ~ 3.6V, VVDD = 2.8 ~ 3.6V.
- 1st-order HPF consists of the input impedance of the MICP pin and MICN pin ($R = \text{typ } 30 \text{ k}\Omega$) and the MICP, MICN pin capacitors "C" before MIC-Amp. The cut-off frequency of the HPF(f_c) is calculated by the following formula.

$$f_c = 1 / (2\pi R C)$$

Mode	PLL3 bit	PLL2 bit	PLL1 bit	PLL0 bit	PLL Reference Clock Input Pin	Input Frequency	R and C of VCOC pin (Note 32)		PLL Lock Time (max)
							R[Ω]	C[F]	
0	0	0	0	0	FCK pin	1fs	6.8k	220n	160ms
1	0	0	0	1	BICK pin	16fs	10k	4.7n	2ms
2	0	0	1	0	BICK pin	32fs	10k	4.7n	2ms
3	0	0	1	1	BICK pin	64fs	10k	4.7n	2ms
4	0	1	0	0	MCKI pin	11.2896MHz	10k	4.7n	10ms
6	0	1	1	0	MCKI pin	12MHz	10k	4.7n	10ms
7	0	1	1	1	MCKI pin	24MHz	10k	4.7n	10ms
12	1	1	0	0	MCKI pin	13.5MHz	10k	10n	10ms
13	1	1	0	1	MCKI pin	27MHz	10k	10n	10ms
Others	Others				N/A				

(default)

Note 32. The tolerance of R is $\pm 5\%$, the tolerance of C is $\pm 30\%$

Table 4. Setting of PLL Mode (*fs: Sampling Frequency, N/A: Not available)

1. Grounding and Power Supply Decoupling

The AK4636 requires careful attention to power supply and grounding arrangements. AVDD, DVDD, SVDD and VVDD are usually supplied from the system's analog supply. If AVDD, DVDD, SVDD and VVDD are supplied separately, the power up sequence is not critical but the PDN pin must be put "L" after all powers are supplied. VSS1, VSS2 and VSS3 of the AK4636 should be connected to the analog ground plane. System analog ground and digital ground should be connected together near to where the supplies are brought onto the printed circuit board. Decoupling capacitors should be as near to the AK4636 as possible, with the small value ceramic capacitor being the nearest.

2. Voltage Reference

VCOM is a signal ground of this chip. A 2.2 μ F electrolytic capacitor in parallel with a 0.1 μ F ceramic capacitor attached to the VCOM pin eliminates the effects of high frequency noise. No load current may be drawn from the VCOM pin. All signals, especially clocks, should be kept away from the VCOM pin in order to avoid unwanted coupling into the AK4636.

3. Analog Inputs

The Microphone input supports both single-ended and differential inputs. The input signal range is 1.5Vpp (typ)@MGAIN = 0dB or 0.15Vpp (typ)@MGAIN = +20dB entered around the internal common voltage 1.15V (typ). Usually the input signal is AC coupled with a capacitor. The cut-off frequency is $f_c = 1/(2\pi RC)$. The AK4636 can accept input voltages from VSS to AVDD.

4. Analog Outputs

The input data format for the DAC is 2's complement. The output voltage is a positive full scale for 7FFFH(@16bit) and a negative full scale for 8000H(@16bit). The ideal output is VCOM voltage for 0000H(@16bit). Mono Line Output from the AOUT pin is 1.5Vpp (typ)@LOVL bit = "0" centered around common voltage 1.15V (typ).

5. Video Inputs

Video inputs are AC coupled with a 0.1 μ F capacitor. This AC coupling capacitor must be 0.1 μ F (in $\pm 30\%$ tolerance). Attention should be given to avoid coupling with other analog and digital signals.

6. Video Outputs

The AK4636 integrates 2ch video amp for driving 150 Ω resistance. The gain of each amp is +6dB@GCA=0dB (typ)

CONTROL SEQUENCE

■ Clock Set up

When ADC, DAC, Digital microphone and Programmable Filter are used, the clocks must be supplied.

1. PLL Master Mode

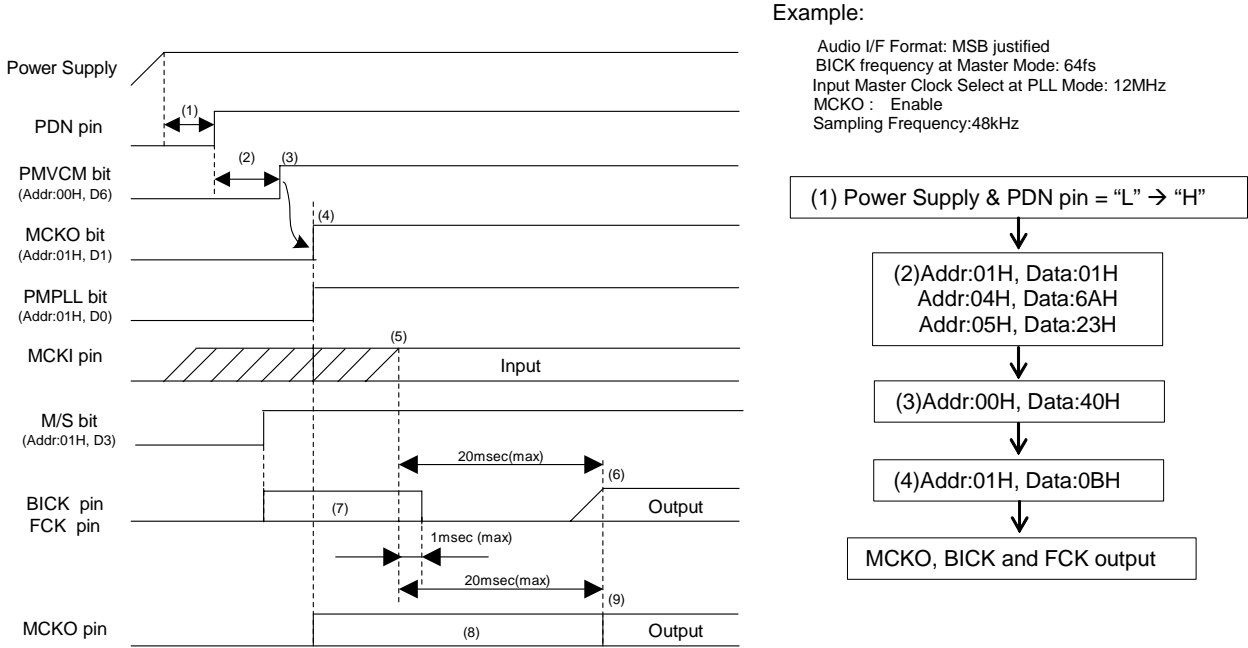

Figure 70. Clock Set Up Sequence (1)

<Example>

- (1) After Power Up, PDN pin = "L" → "H"
 "L" time (1) of 150ns or more is needed to reset the AK4636.
- (2) DIF1-0, PLL3-0, FS3-0, BCKO1-0, MSBS, BCKP and M/S bits must be set during this period.
- (3) Power Up VCOM: PMVCM bit = "0" → "1"
 VCOM should first be powered-up before the other block operates.
- (4) In case of using MCKO output: MCKO bit = "1"
 In case of not using MCKO output: MCKO bit = "0"
- (5) PLL lock time is 20ms(max) after PMPLL bit changes from "0" to "1" and MCKI is supplied from an external source.
- (6) The AK4636 starts to output the FCK and BICK clocks after the PLL becomes stable and the normal operation starts.
- (7) The invalid frequencies are output from FCK and BICK pins during this period.
- (8) The invalid frequency is output from the MCKO pin during this period.
- (9) The normal clock is output from the MCKO pin after the PLL is locked.

2. When the external clock (FCK or BICK pin) is used in PLL Slave mode.

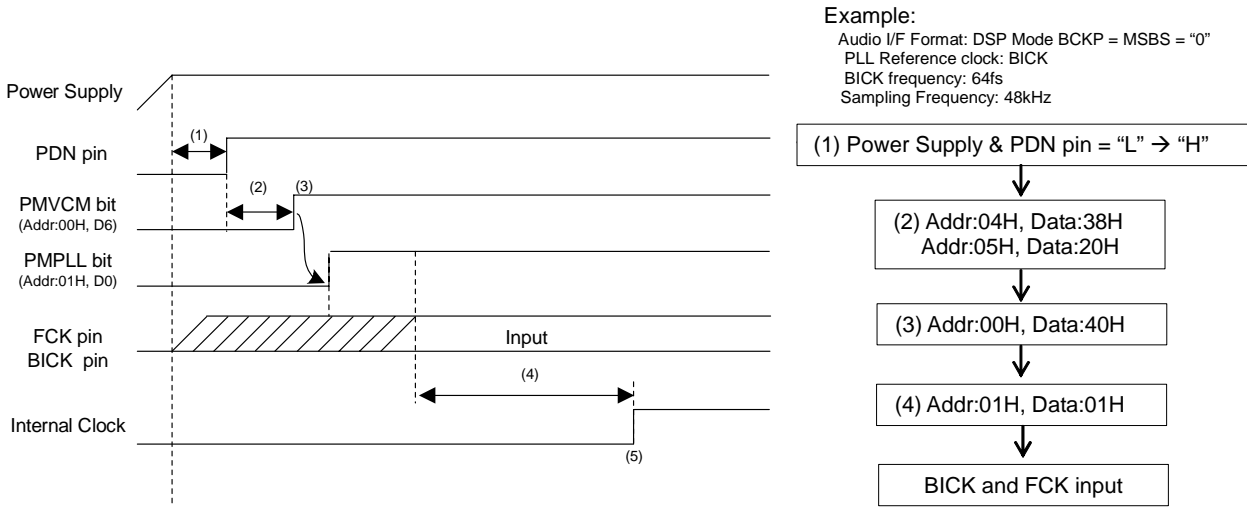

Figure 71. Clock Set Up Sequence (2)

<Example>

- (1) After Power Up: PDN pin "L" → "H"
 "L" time (1) of 150ns or more is needed to reset the AK4636.
- (2) DIF1-0, FS3-0, PLL3-0, MSBS and BCKP bits must be set during this period.
- (3) Power Up VCOM: PMVCM bit = "0" → "1"
 VCOM should first be powered up before the other block operates.
- (4) PLL starts after the PMPLL bit changes from "0" to "1" and PLL reference clocks (FCK or BICK pin) are supplied. PLL lock time is 160ms(max) when PLL reference clock is FCK, and PLL lock time is 2ms(max) when PLL reference clock is BICK.
- (5) Normal operation starts after the PLL is locked.

3. When the external clock (MCKI pin) is used in PLL Slave mode.

Example:

Audio I/F Format: MSB justified
 BICK frequency at Master Mode: 64fs
 Input Master Clock Select at PLL Mode: 12MHz
 MCKO : Enable
 Sampling Frequency:48kHz

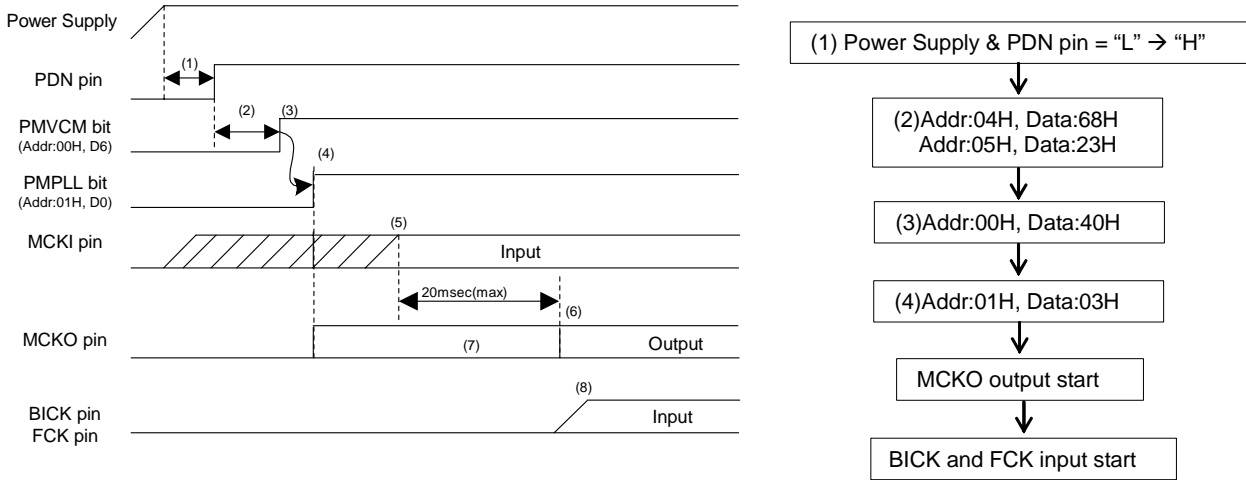

Figure 72. Clock Set Up Sequence (3)

<Example>

- (1) After Power Up: PDN pin “L” → “H”
 “L” time (1) of 150ns or more is needed to reset the AK4636.
- (2) DIF1-0, PLL3-0, FS3-0, BCKO1-0, MSBS, BCKP and M/S bits must be set during this period.
- (3) Power Up VCOM: PMVCM bit = “0” → “1”
 VCOM should first be powered up before the other block operates.
- (4) PLL Power Up: PMPLL bit “0” → “1”
- (5) PLL lock time is 20ms(max) after the PMPLL bit changes from “0” to “1” and PLL reference clock (MCKI pin) is supplied.
- (6) Normal clock is output from the MCKO pin after PLL is locked.
- (7) The invalid frequency is output from the MCKO pin during this period.
- (8) BICK and FCK clocks should be synchronized with MCKO clock.

4. EXT Slave Mode

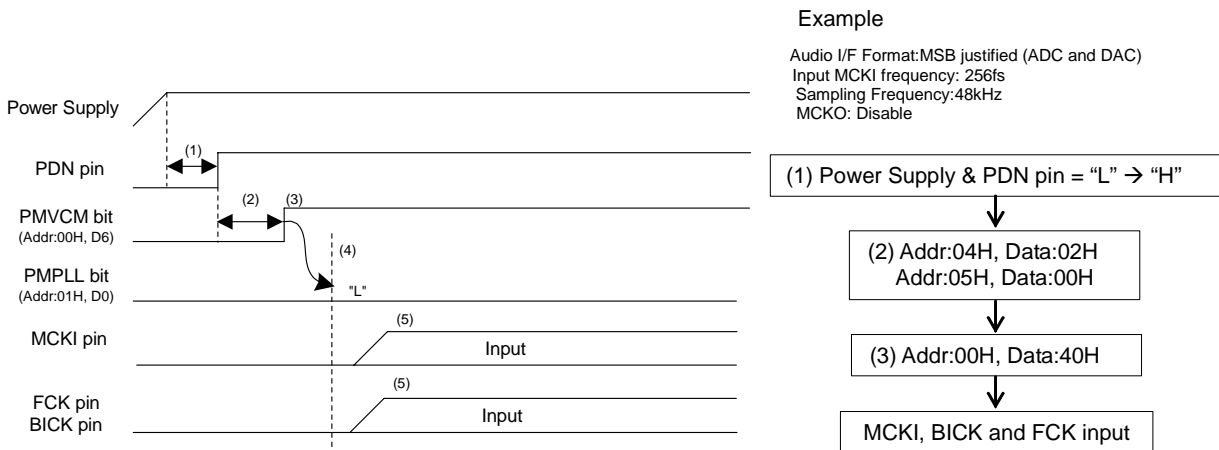

Figure 73. Clock Set Up Sequence (4)

<Example>

- (1) After Power Up: PDN pin “L” → “H”
“L” time (1) of 150ns or more is needed to reset the AK4636.
- (2) DIF1-0 and FS1-0 bits should be set during this period.
- (3) Power Up VCOM: PMVCM bit = “0” → “1”
VCOM should first be powered up before the other block operates.
- (4) Power down PLL: PMPLL bit = “0”
- (5) Normal operation starts after the MCKI, FCK and BICK are supplied.

■ Digital MIC Inputs

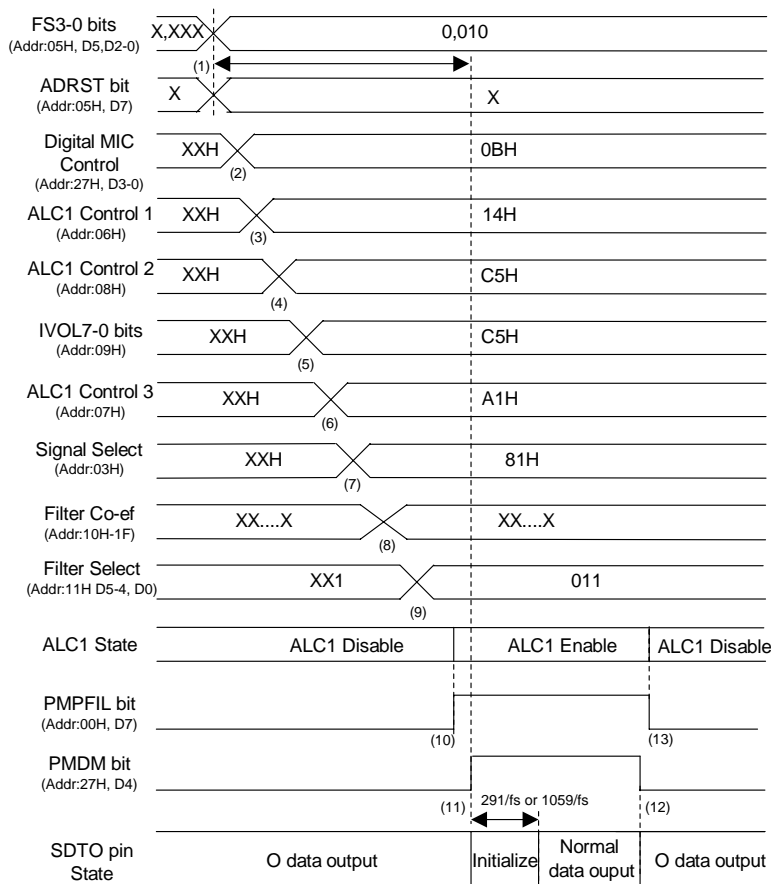
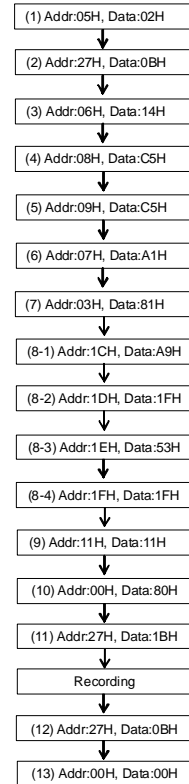

Figure 74. Digital MIC Input Recording Sequence

Example:

PLL Master Mode
 Audio I/F Format: MSB justified
 Sampling Frequency: 16kHz
 Digital MIC settings:
 Data is latched on the DMCLK falling edge
 Digital MIC Power Supply "Externally"
 ALC1 setting Refer to Table 36
 HPF : ON (fc=15kHz)
 4+1 band EQ : OFF



<Example>

This sequence is an example of ALC1 setting at $f_s=16\text{kHz}$. If the parameter of the ALC1 is changed, please refer to the [Figure 47](#).

At first, clocks should be supplied according to "Clock Set Up" sequence.

- (1) Set up a sampling frequency (FS3-0 bit) and the initializing cycle of programmable filter (ADRST bit). When the AK4636 is in PLL mode, MIC and Programmable filter should be powered-up in consideration of PLL lock time after the sampling frequency is changed.
- (2) Set up Digital MIC(address 27H)
- (3) Set up Timer Select for ALC1 (Addr: 06H)
- (4) Set up REF value for ALC1 (Addr: 08H)
- (5) Set up IVOL value for ALC1 (Addr: 09H)
- (6) Set up LMTH0, RGAIN0, LMAT1-0, ZELM and ALC1 bits (Addr: 07H)
- (7) Set up Programmable Filter Path: PFSDO bit = ADCPF bit = "1"
- (8) Set up Coefficient of the Programmable Filter (HPF/EQ) Addr: 1CH ~ 1FH, 2CH ~ 2FH, 32H ~ 4FH
- (9) Switch ON/OFF of the Programmable Filter (HPF/EQ)
- (10) Power-up Programmable Filter: PMPFIL bit = "0" → "1"
- (11) Power-up Digital MIC: PMDM bit = "0" → "1"
 The initializing cycle of the digital filter is $1059/f_s = 24\text{ms}@f_s=44.1\text{kHz}$ when ADRST bit = "0", and $291/f_s=18\text{ms}@16\text{kHz}$ when ADRST bit = "1". ALC starts operating at the value set by IVOL (5).
- (12) Power-down Digital MIC: PMDM bit = "1" → "0"
- (13) Power-down Programmable Filter: PMPFIL bit = "1" → "0"

■ MIC Input Recording

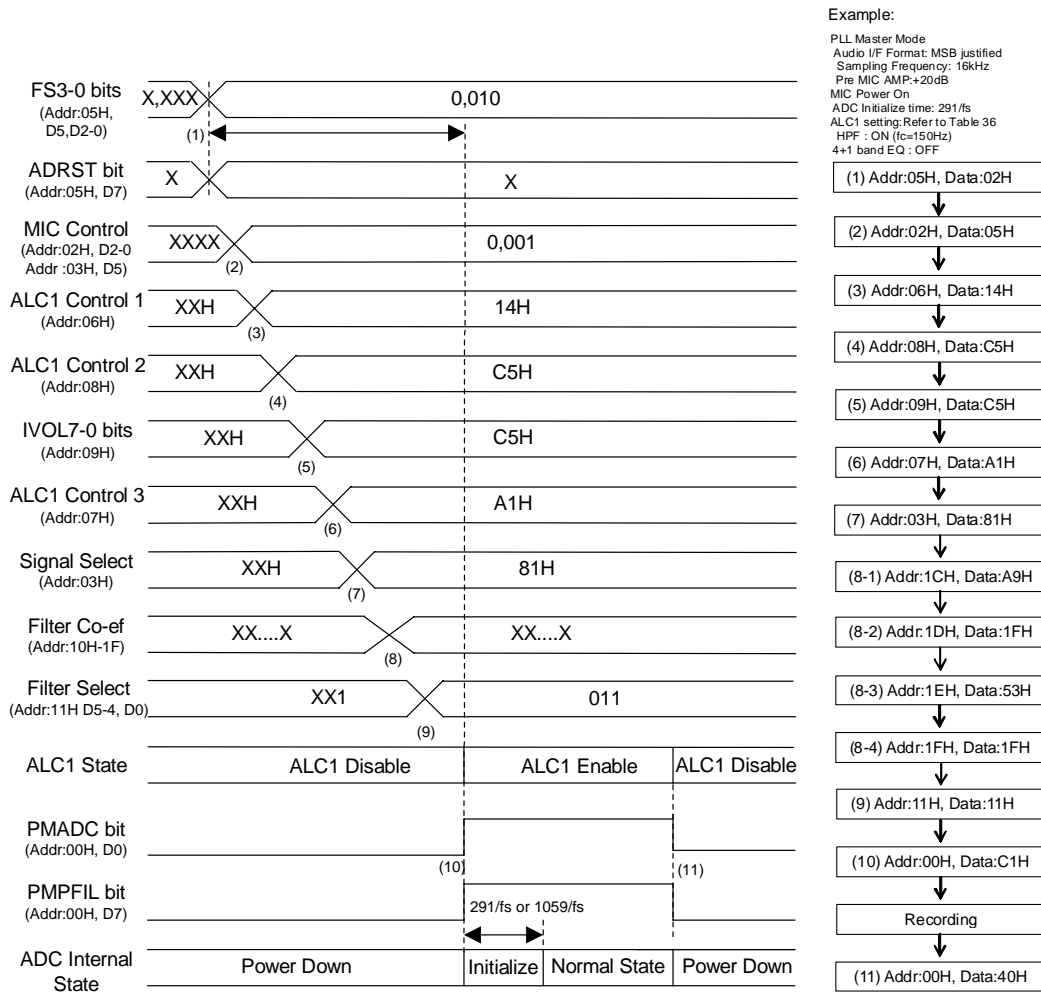

Figure 75. MIC Input Recording Sequence

<Example>

This sequence is an example of ALC1 setting at fs=16kHz. If the parameter of the ALC1 is changed, please refer to the Figure 47.

At first, clocks should be supplied according to “Clock Set Up” sequence.

- (1) Set up a sampling frequency (FS3-0 bit). When the AK4636 is in PLL mode, programmable filter and ADC should be powered-up in consideration of PLL lock time after the sampling frequency is changed.
- (2) Set up MIC input (Addr: 02H)
- (3) Set up Timer Select for ALC1 (Addr: 06H)
- (4) Set up REF value for ALC1 (Addr: 08H)
- (5) Set up IVOL value for ALC1 (Addr: 09H)
- (6) Set up LMTH0, RGAIN0, LMAT1-0, ZELM and ALC1 bits (Addr: 07H)
- (7) Set up Programmable Filter Path: PFSDO bit = ADCPF bit = “1”
- (8) Set up Coefficient of the Programmable Filter (HPF/EQ) Addr: 1CH ~ 1FH, 2CH ~ 2FH, 32H ~ 4FH
- (9) Switch ON/OFF of the Programmable Filter
- (10) Power-up of the ADC and Programmable Filter: PMPFIL bit = PMADC bit = “0” → “1”
 The initialization cycle of the ADC is 1059/fs=24ms@fs=44.1kHz when ADRST bit = “0”,
 291/fs=18ms@fs=16kHz when ADRST bit = “1”. ALC starts operating at the value set by IVOL (5).
- (11) Power-down of the ADC and Programmable Filter: PMPFIL bit = PMADC bit = “1” → “0”

■ Mono Lineout

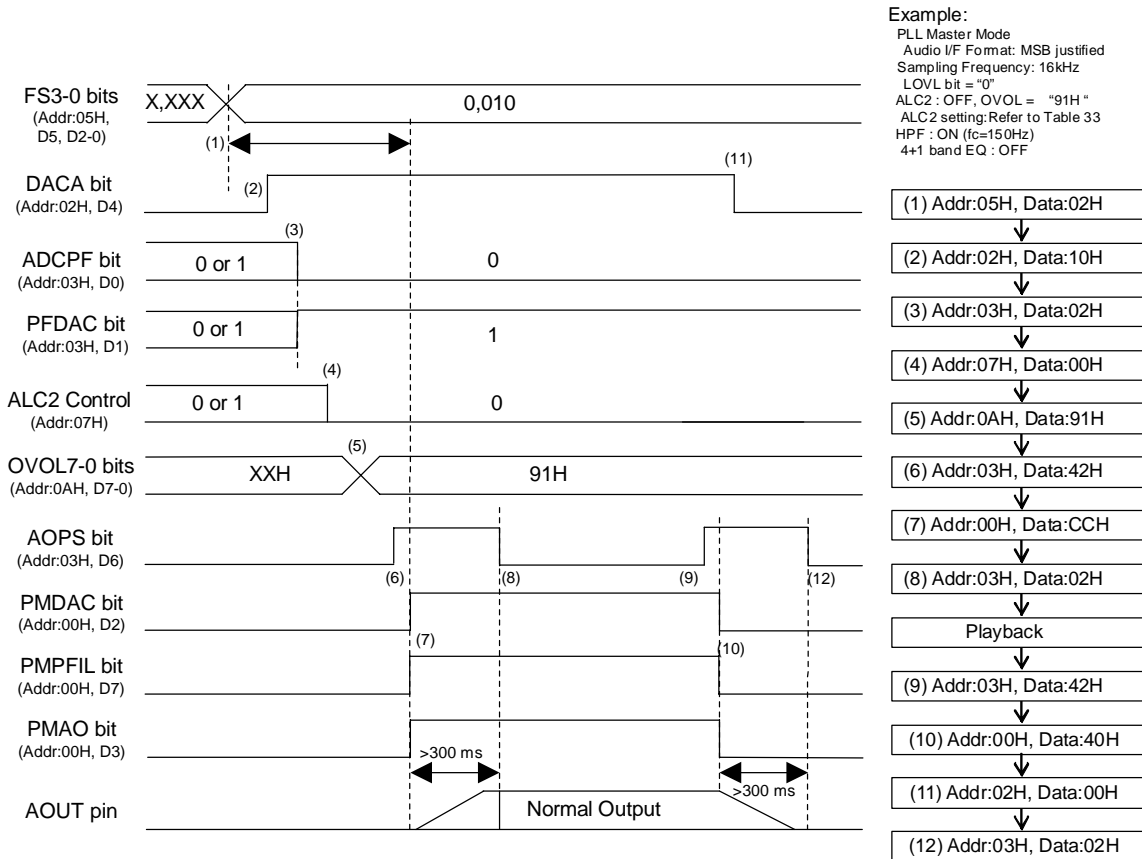

Figure 76. Mono Lineout Sequence

<Example>

In case of using digital volume in manual mode

At first, clocks should be supplied according to "Clock Set Up" sequence.

- (1) Set up the sampling frequency (FS3-0 bits). When the AK4636 is PLL mode, DAC should be powered-up in consideration of PLL lock time after the sampling frequency is changed.
- (2) Set up the path of "DAC → Mono Line Amp"
 DACA bit: "0" → "1"
- (3) Set up the path: ADCPF bit = "0", PFDAC bit = "1"
- (4) ALC2 Disable: ALC2 bit = "0"
- (5) Set up the digital volume (Addr: 0AH)
- (6) AOUT power save mode: AOPS bit: "0" → "1"
- (7) Power-up of DAC, Programmable Filter and Mono Line Amp:
 PMDAC bit = PMPFIL bit = PMAO bit = "0" → "1"
 AOUT pin goes to "H". It takes 300ms (max) when C = 1μF
- (8) Exit power save mode of AOUT: AOPS bit = "1" → "0"
 Set up AOPS bit after AOUT became "H", then the AOUT pin starts outputting data.
- (9) Enter power save mode of AOUT: AOPS bit = "0" → "1"
- (10) Power-down the DAC, Programmable Filter and Mono Line Amp:
 PMDAC bit = PMPFIL bit = PMAO bit = "1" → "0"
 The AOUT pin starts going to "L". It takes 300ms(max) when C = 1μF.
- (11) Disable the path of "DAC → Mono Line Amp": DACA bit = "1" → "0"
- (12) Exit power save mode of AOUT: AOPS bit = "1" → "0"
 Set up AOPS bit after AOUT became "L".

■ Speaker-amp Output

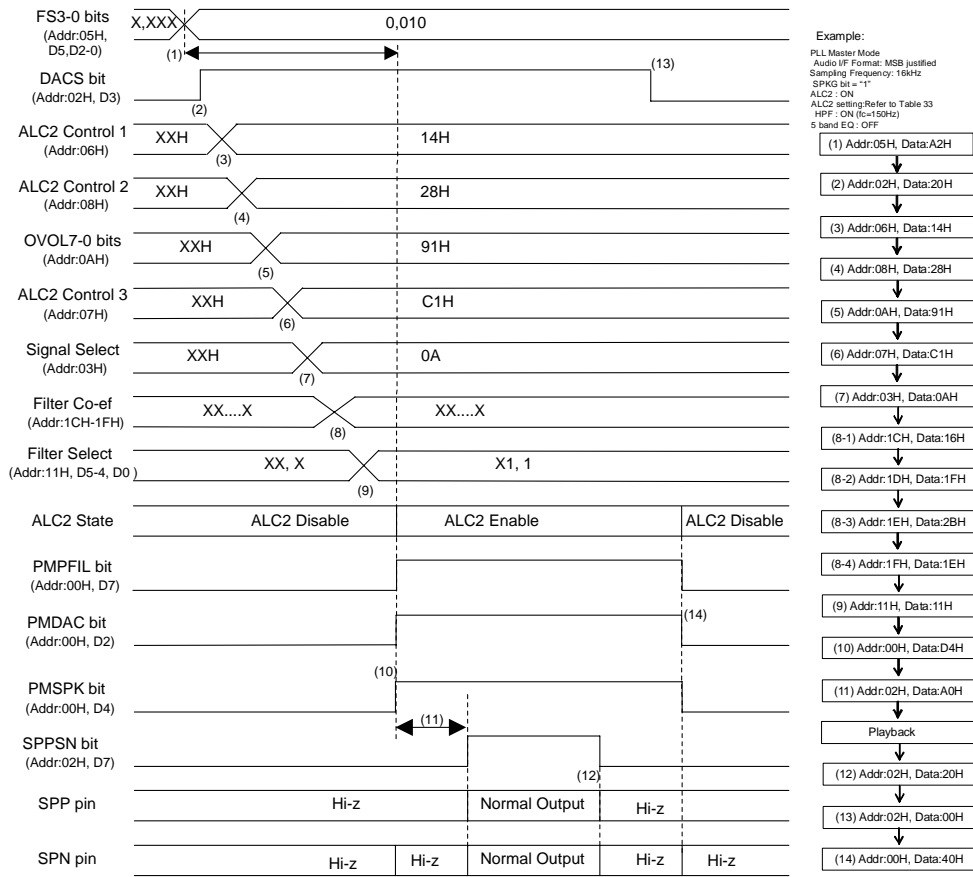

Figure 77. Speaker-Amp Output Sequence

<Example>

In case of fs=16kHz. Refer to the Table 37 for changing ALC2 parameter.

At first, clocks should be supplied according to “Clock Set Up” sequence.

- (1) Set up a sampling frequency (FS3-0 bits). When the AK4636 is PLL mode, DAC and Speaker-Amp should be powered-up in consideration of PLL lock time after a sampling frequency is changed.
- (2) Set up the path of “DAC → SPK-Amp”: DACS bit = “0” → “1”
- (3) Set up Timer Select for ALC2 (Addr: 06H)
- (4) Set up REF value for ALC2 (Addr: 08H)
- (5) Set up OVOL value, RGAIN1 and LMTH1 for ALC2 (Addr: 10H)
- (6) Set up LMTH0, RGAIN0, LMAT1-0, ZELM and ALC2 bit (Addr: 07H)
- (7) Set up the Programmable Filter Path and SPK-Amp Gain:
 PFDAC bit = “1”, ADCPF bit = “0”, SPKG bit = “X”
- (8) Set up Coefficient of the Programmable Filter (HPF/EQ) Addr: 1C ~ 1FH, 2CH ~ 2FH, 32H ~ 4FH
- (9) Switch ON/OFF of the Programmable Filter
- (10) Power-up of the DAC, SPK-Amp and Programmable Filter:
 PMDAC bit = PMSPK bit = PMPFIL bit = “0” → “1”
- (11) Enable Speaker Output: SPPSN bit = “0” → “1”
 1ms or more time is needed before setting SPPSN bit = “1” after setting PMSPK bit = “1”.
- (12) Disable Speaker Output: SPPSN bit = “1” → “0”
- (13) Disable the path of “DAC → SPK-Amp”: DACS bit = “1” → “0”.
- (14) Power down of the DAC, SPK-Amp and Programmable Filter:
 PMDAC bit = PMSPK bit = PMPFIL bit = “1” → “0”

■ BEEP Signal Output from Speaker-Amp

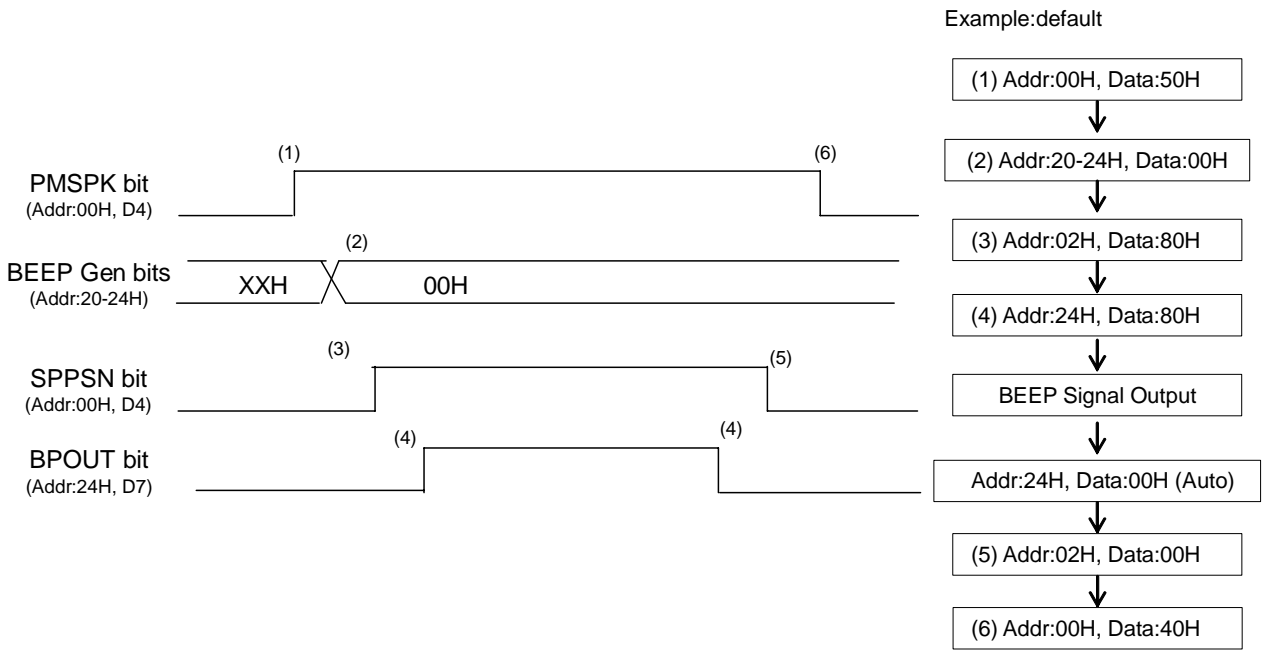

Figure 78. “BEPP Generator → Speaker-Amp” Output Sequence

<Example>

At first, clocks should be supplied according to “Clock Set Up” sequence.

- (1) Power Up BEEP-Generator and Speaker-Amp: PMSPK bit = “0” → “1”
- (2) Set up BEEP Generator (Addr: 20H ~ 24H)(When repeat output time BPCNT bit = “0”)
- (3) Enable SPK-Amp Output: SPPSN bit = “0” → “1”
- (4) BEEP Output: BPOUT bit= “0” → “1” (after outputting data particular set times, BPOUT bit automatically goes to “0”)
- (5) Disable Speaker Output: SPPSN bit = “1” → “0”
- (6) Power down of the SPK-Amp: PMSPK bit = “1” → “0”

■ Video Signal Input and Output

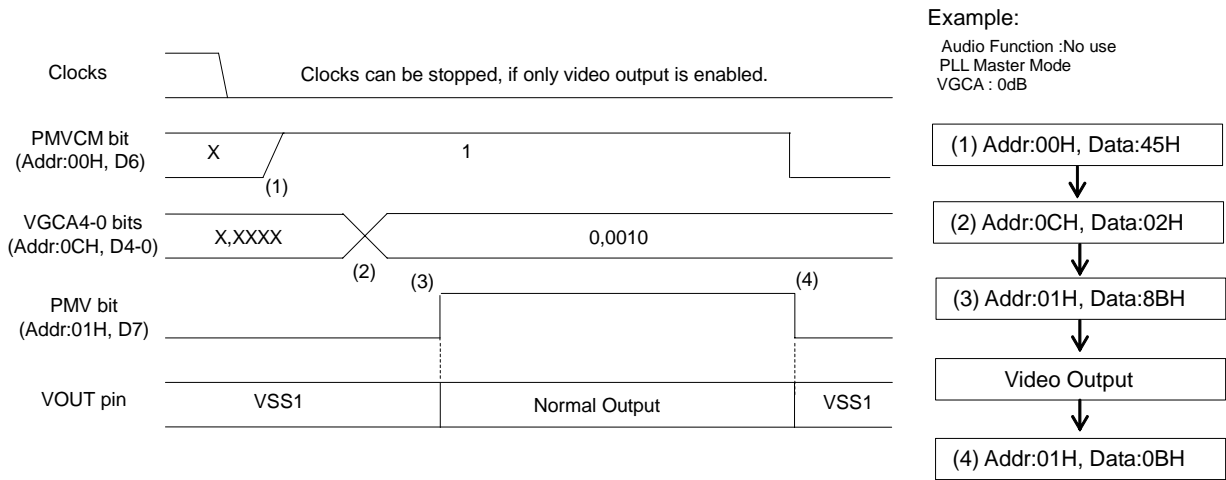

Figure 79. Video Output Sequence

<Example>

When only the video block is operated, the clocks are not needed to be supplied.

(1) Power up VCOM: PMVCM bit = "X" → "1"

(2) Set up the GCA gain (VGCA4-0 bits)

(3) Power up the Video Amp: PMV bit = "0" → "1"

The signal input to the VIN pin is output from the VOUT pin.

(4) Power down of the Video Amp: PMV bit = "1" → "0"

The output from the VOUT pin will stop and goes to 0V. Then VCOM can be powered-down when not using any audio functions.

■ Stop of Clock

Master clock can be stopped when ADC, DAC and Programmable Filter are not in operation.

1. PLL Master Mode

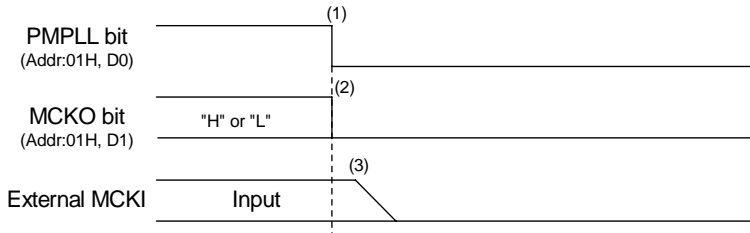

Example:

Audio I/F Format: MSB justified
 BICK frequency at Master Mode: 64fs
 Input Master Clock Select at PLL Mode: 12MHz
 MCKO : Enable
 Sampling Frequency:48kHz

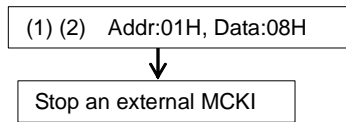
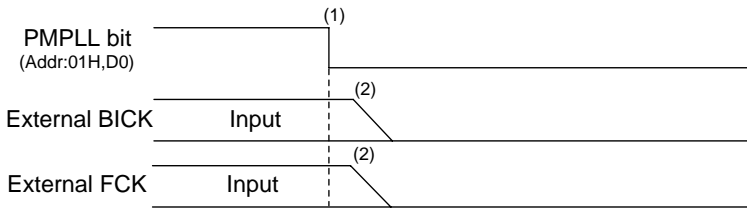

Figure 80. Clock Stopping Sequence (1)

<Example>

- (1) Power down PLL: PMPLL bit = "1" → "0"
- (2) Stop MCKO clock: MCKO bit = "1" → "0"
- (3) Stop an external master clock

2. PLL Slave Mode (FCK, BICK pin)



Example

Audio I/F Format: DSP Mode BCKP = MSBS = "0"
 PLL Reference clock: BICK
 BICK frequency: 64fs
 Sampling Frequency: 48kHz

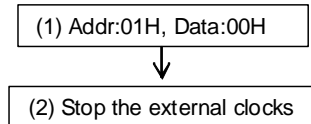
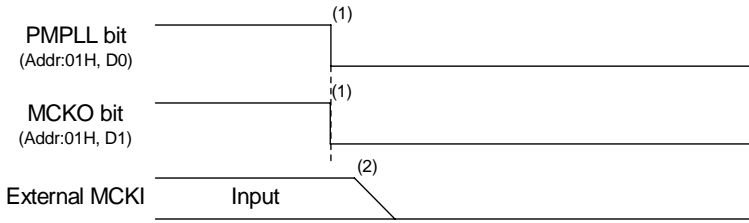

Figure 81. Clock Stopping Sequence (2)

<Example>

- (1) Power down of the PLL: PMPLL bit = "1" → "0"
- (2) Stop an external master clock

3. PLL Slave Mode (MCKI pin)



Example

Audio I/F Format: MSB justified
 BICK frequency at Master Mode: 64fs
 Input Master Clock Select at PLL Mode: 12MHz
 MCKO : Enable
 Sampling Frequency:48kHz

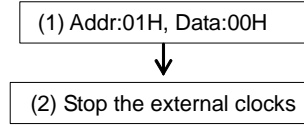
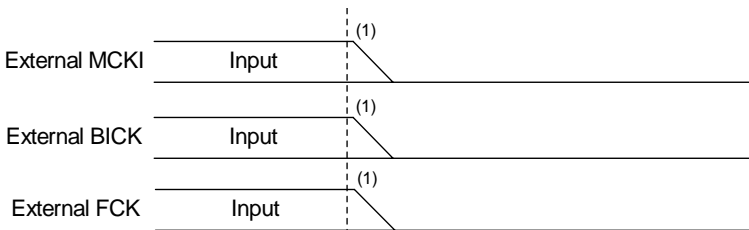

Figure 82. Clock Stopping Sequence (3)

<Example>

- (1) Power down of the PLL: PMPLL bit = “1” → “0”
 Stop the MCKO output: MCKO bit = “1” → “0”
- (2) Stop an external master clock.

4. EXT Slave Mode



Example

Audio I/F Format: MSB justified
 BICK frequency at Master Mode: 64fs
 Input Master Clock Select at PLL Mode: 12MHz
 MCKO : Enable
 Sampling Frequency:48kHz

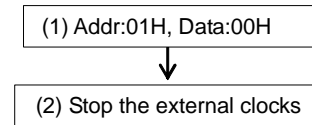

Figure 83. Clock Stopping Sequence (4)

<Example>

- (1) Stop an external master clock.

■ Power Down

VCOM should be powered-down after the master clock is stopped if clocks are supplied when all blocks except for VCOM are powered-down. The AK4636 is also powered-down by the PDN pin = “L”. In this case, the registers are initialized.

PACKAGE (AK4636ECB)

29pin CSP: 2.5mm x 3.0mm

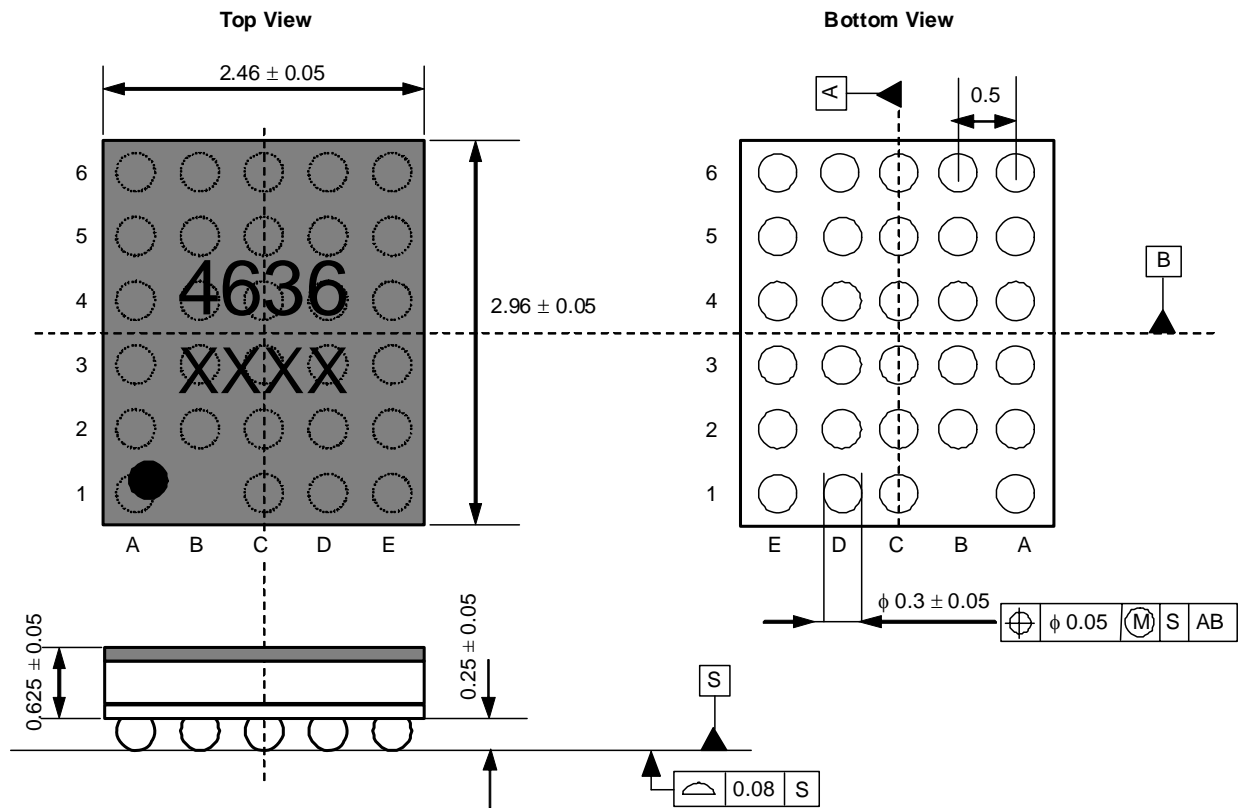

■ Material & Lead finish

Package material: Epoxy resin, Halogen (bromine and chlorine) free
 Solder ball material: SnAgCu

MARKING (AK4636ECB)

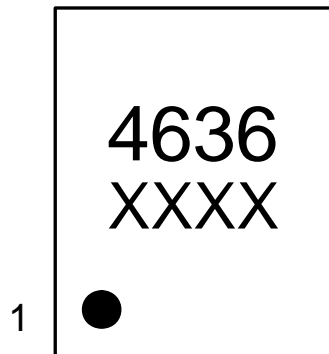

A

"4636": Market Number
XXXX: Date code (4 digit)
●: Pin #1 indication

MARKING (AK4636EN)

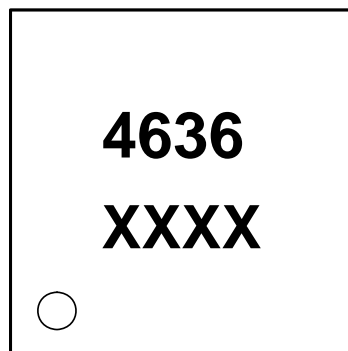

XXXX: Date code identifier (4 digit)

REVISION HISTORY

Date (Y/M/D)	Revision	Reason	Page	Contents
09/02/27	00	First Edition		
10/08/19	01	Error Correction	46	Transfer function was changed. “ $H(z) = \{1 + h_2(z) + h_3(z) + h_4(z) + h_5(z)\} \times h_1(z)$ ” → “ $H(z) = \{1 + h_2(z) + h_3(z) + h_4(z) + h_5(z)\} \times \{1+h_1(z)\}$ ”
11/07/26	02	Specification Change	53	3. The Volume at ALC Operation A description was added.
			72	■ Register Map Note 46 was changed.
			79	■ Register Definitions 0DH: Note 48 was added.

IMPORTANT NOTICE

- These products and their specifications are subject to change without notice.
When you consider any use or application of these products, please make inquiries the sales office of Asahi Kasei Microdevices Corporation (AKM) or authorized distributors as to current status of the products.
- Descriptions of external circuits, application circuits, software and other related information contained in this document are provided only to illustrate the operation and application examples of the semiconductor products. You are fully responsible for the incorporation of these external circuits, application circuits, software and other related information in the design of your equipments. AKM assumes no responsibility for any losses incurred by you or third parties arising from the use of these information herein. AKM assumes no liability for infringement of any patent, intellectual property, or other rights in the application or use of such information contained herein.
- Any export of these products, or devices or systems containing them, may require an export license or other official approval under the law and regulations of the country of export pertaining to customs and tariffs, currency exchange, or strategic materials.
- AKM products are neither intended nor authorized for use as critical components^{Note1)} in any safety, life support, or other hazard related device or system^{Note2)}, and AKM assumes no responsibility for such use, except for the use approved with the express written consent by Representative Director of AKM. As used here:
 - Note1) A critical component is one whose failure to function or perform may reasonably be expected to result, whether directly or indirectly, in the loss of the safety or effectiveness of the device or system containing it, and which must therefore meet very high standards of performance and reliability.
 - Note2) A hazard related device or system is one designed or intended for life support or maintenance of safety or for applications in medicine, aerospace, nuclear energy, or other fields, in which its failure to function or perform may reasonably be expected to result in loss of life or in significant injury or damage to person or property.
- It is the responsibility of the buyer or distributor of AKM products, who distributes, disposes of, or otherwise places the product with a third party, to notify such third party in advance of the above content and conditions, and the buyer or distributor agrees to assume any and all responsibility and liability for and hold AKM harmless from any and all claims arising from the use of said product in the absence of such notification.