

# AC-DC Battery Backed Power Supply



[www.powersolve.co.uk](http://www.powersolve.co.uk)

## PQE75-100 Series 75-100W Enclosed 1-3 Outputs with Battery Charger

### Features

- Universal AC Input
- Auto Switch when Power Off (UPS Function)
- Built-in Constant Current Limiting Circuit
- Alarm Signals for AC OK & Battery Low
- Short Circuit, Overload, Over Voltage Protections
- Brown Out (AC Input Voltage Low) Protection
- Battery Low Protection
- Battery Polarity (by resettable fuses) Protection
- Cooling by Free Air Convection



### Electrical Specification

Input Voltage	90-264VAC, 47-63Hz / 127-373VDC (withstand 300VAC surge for 5 sec. without damage)
AC Input Current (typ.)	PQE75: 1.5A at 115VAC / 1.0A at 230VAC PQE100: 2A at 115VAC / 1.2A at 230VAC
Inrush Current	35A at 115VAC / 70A at 230VAC
Leakage Current	<1mA at 264VAC
Output Voltage	See Table
Output Current	See Table
Voltage Adjust Range	±10% typical adjustment by potentiometer (CH1 only)
Voltage Tolerance (see note 3)	CH1: ±2%, CH3: ±3%
Set Up, Rise Time	800ms, 30ms at full load
Hold Up Time (typ.)	50ms at 230VAC / 8ms at 115VAC, full load
Overload Protection	>110% of rated output power for CH1 & CH3 (GB/LB only) / >100% rated output power for CH2 Protection type: Hiccup mode, recovers automatically.
Overvoltage Protection	115-140% of rated output voltage for CH1. Protection type: latch off mode
Low Battery Cut Off	10V ±5% for 13.8V version / 20V ±5% for 27.6V version
Low Battery Signal	<12V ±3% for 13.8V versions / <22V ±3% for 27.6V version
AC OK Signal	TTL open collector output for G & L versions / Relay contact output for GB & LB versions
Operating Temp. Range	-20°C to +70°C (with derating. see derating curves)
Operating Humidity	20-90% RH non-condensing
Storage Temp. Range	-40°C to +85°C
Storage Humidity	20-90% RH non-condensing
Temperature Coefficient	±0.03%/°C (0-50°C) on CH1
Vibration	10-500Hz, 2G 10min./1 cycle, period for 60 min, each along X, Y & Z axis
Safety Standards	meets UL60950-1, TUV EN60950-1 approved
Withstand Voltage	I/P-O/P: 3KVAC, I/P-FG: 1.5KVAC, O/P-FG: 0.5KVAC
Isolation Resistance	I/P-O/P: 100MΩ / 500VDC
EMI Conduction & Radiation	EN55022: 2006+A1 : 2007 Class B
Harmonic Current	EN61000-3-2: 2006 Class A, EN61000-3-3 : 2008
EMS Immunity	EN61000-4-2, 3, 4, 5, 6, 8, 11, ENV50204, EN55024
Cooling	Free Air Convection
Dimensions	129.5(L) x 97.5(W) x 37.5(H) mm

#### Notes:

1. All parameters NOT specifically mentioned are measured at 230VAC input, rated load and 25°C ambient temperature
2. Ripple and noise are measured at 20MHz bandwidth by using a 12" twisted pair wire terminated with a 0.1µF ceramic & 47µF electrolytic capacitors across the output
3. Tolerance: includes set up tolerance, line regulation and load regulation
4. Line regulation is measured from low line to high line at rated load
5. Load regulation is measured from 10% to 100% rated load
6. The power supply is considered a component which will be installed into a final equipment. The final equipment must be re-confirmed that it still meets EMC Directives
7. Length of set up time is measured at cold start. Turning the power supply ON/OFF very quickly may lead to increased set up time
8. The total power output can not exceed the rated power, maximum output current is per channel.
9. CH2: Battery discharge current can not exceed 50% of the rated power.
10. Do not connect the DC Output GND port with Battery -ve port to avoid damage to power supply

# AC-DC Battery Backed Power Supply



[www.powersolve.co.uk](http://www.powersolve.co.uk)

## Output Voltage and Current Ratings

MODEL		OUTPUT VOLTAGE	OUTPUT CURRENT RATED	OUTPUT CURRENT MAX. (8)	RIPPLE & NOISE (2)	LINE REG. (4)	LOAD REG. (5)	POWER Max.	EFF.
PQE75-G	CH1	13.8V	3.7A	5.5A	100mV p-p	±0.5%	±0.5%	75.9W	86%
	CH2	13.8V	1.8A	2.07A	150mV p-p				
PQE75-GB	CH1	13.8V	2.6A	4.4A	100mV p-p	±0.5%	±0.5%	75.72W	85%
	CH2	13.8V	1.8A	2.07A	150mV p-p				
	CH3	5.0V	3.0A	3.0A	100mV p-p	±0.5%	±1.5%		
PQE75-L	CH1	27.6V	1.75A	2.75A	100mV p-p	±0.5%	±0.5%	75.9W	88%
	CH2	27.6V	1.0A	1.15A	150mV p-p				
PQE75-LB	CH1	27.6V	1.2A	2.2A	100mV p-p	±0.5%	±0.5%	75.72W	87%
	CH2	27.6V	1.0A	1.15A	150mV p-p				
	CH3	5.0V	3.0A	3.0A	100mV p-p	±0.5%	±1.5%		
PQE100-G	CH1	13.8V	4.8A	7.3A	100mV p-p	±0.5%	±0.5%	100.74W	86%
	CH2	13.8V	2.5A	2.875A	150mV p-p				
PQE100-GB	CH1	13.8V	3.7A	6.2A	100mV p-p	±0.5%	±0.5%	100.56W	85%
	CH2	13.8V	2.5A	2.875A	150mV p-p				
	CH3	5.0V	3.0A	3.0A	100mV p-p	±0.5%	±1.5%		
PQE100-L	CH1	27.6V	2.15A	3.65A	100mV p-p	±0.5%	±0.5%	100.74W	87%
	CH2	27.6V	1.5A	1.725A	150mV p-p				
PQE100-LB	CH1	27.6V	1.6A	3.1A	100mV p-p	±0.5%	±0.5%	100.56W	85%
	CH2	27.6V	1.5A	1.725A	150mV p-p				
	CH3	5.0V	3A	3.0A	100mV p-p	±0.5%	±1.5%		

## Mechanical & Connection Details

### Input/Output (CN1)

Pin	Function
1	Live
2	Neutral
3	Earth
4	DC O/P GND
5	DC O/P V+
6	Battery +ve
7	Battery -ve
8	+5V (GB/LB only)

### Alarm Output (CN2) G/L versions

1	AC OK
2	BAT Low
3	G (13.8V/20mA)
	L (27.6V/20mA)

Mating connector: JST XHP-3 or equivalent  
Terminals: JST SXH-001T-P0.6 or equivalent

### Alarm Output (CN2) GB/LB versions

1 & 2	AC OK (relay contacts)
3 & 4	BAT Low (relay contacts)

Mating connector: JST XHP-4 or equivalent  
Terminals: SXH-001T-P0.6 or equivalent

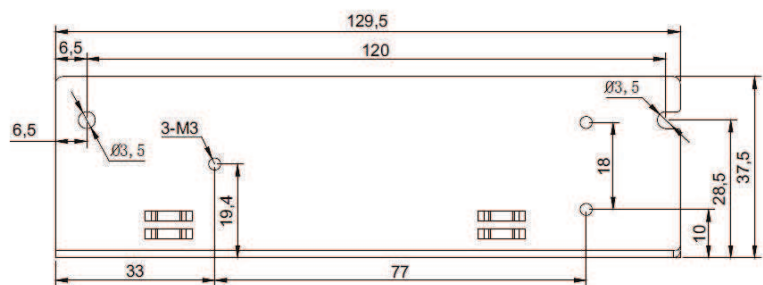
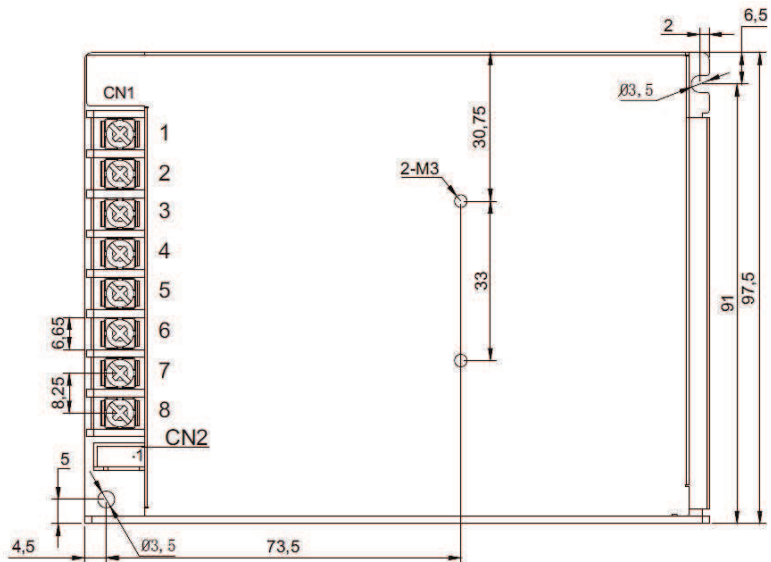

# AC-DC Battery Backed Power Supply



www.powersolve.co.uk

## Derating Curves

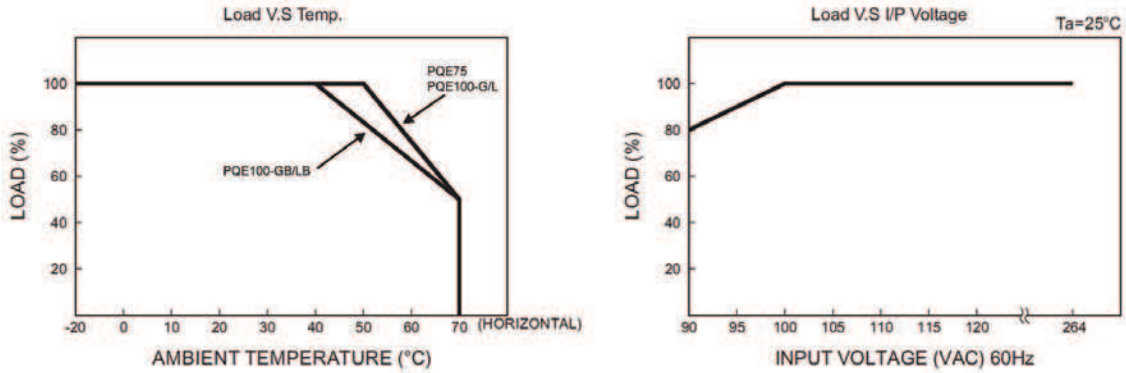

## Block Diagram and Alarm Signals (G & L versions)

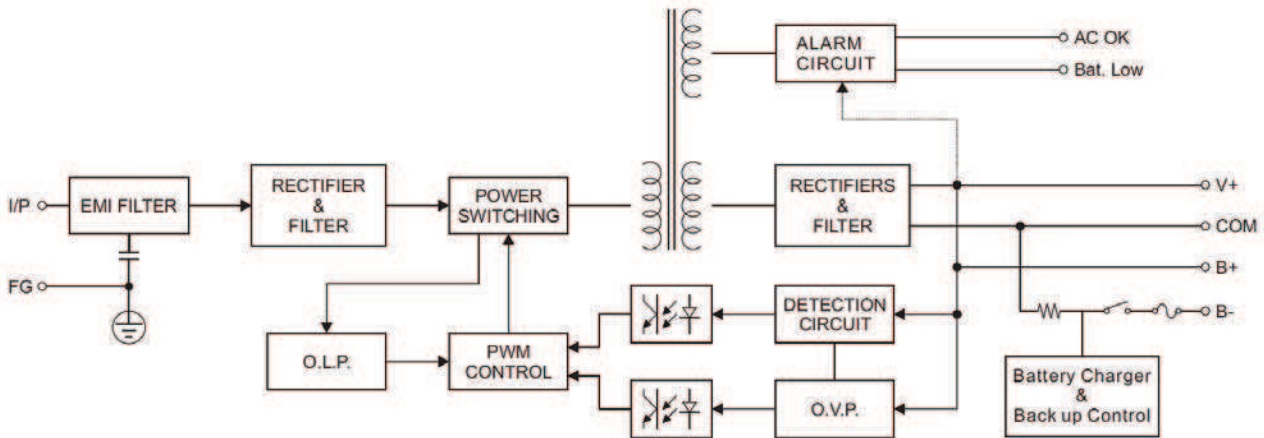

### Alarm Signals for AC OK and Battery Low

- These signals are open collector transistors and therefore an external voltage source and pull-up resistors are required
- The maximum applied external voltage is 50V and the maximum sink current is 30mA

Function	Description	Output of alarm
AC OK	Signal is 'LOW' when the power supply turns on.	Low (0.3V max. at 30mA)
	Signal is 'HIGH' when the power supply turns off	High or open (externally applied voltage 30mA max.)
BAT. LOW	Signal is 'LOW' when battery voltage is under G:12V, L:22V	Low (0.3V max. at 30mA)
	Signal is 'HIGH' when battery voltage is above G:12V, L:22V	High or open (externally applied voltage 30mA max.)

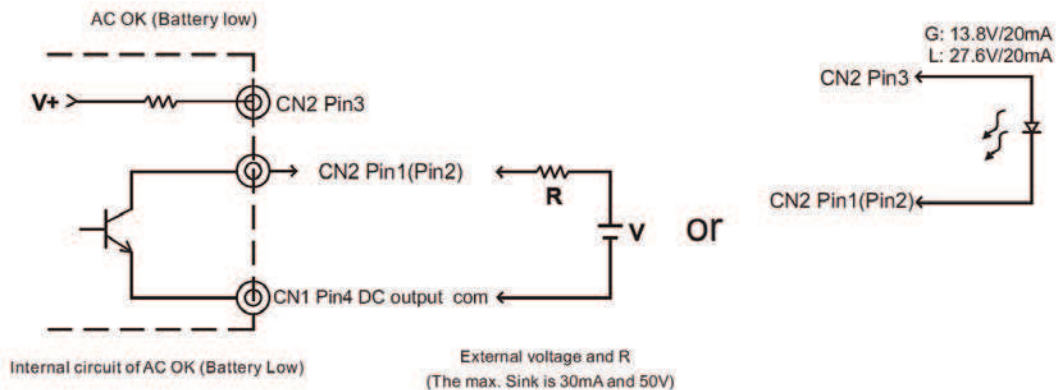

# AC-DC Battery Backed Power Supply



www.powersolve.co.uk

## Block Diagram and Alarm Signals (GB & LB versions)

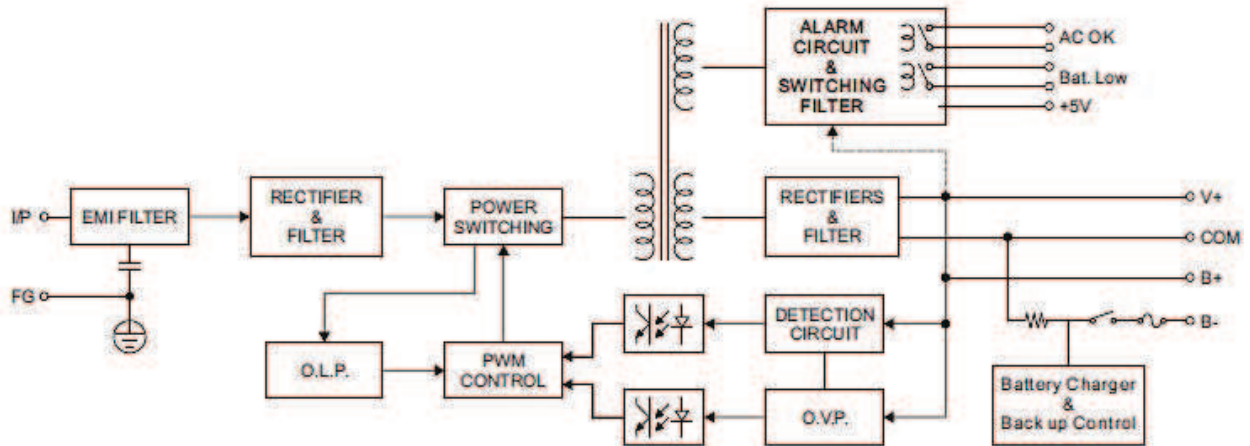

### Alarm Signals for AC OK and Battery Low

- These signals are volt free relay contacts and therefore an external voltage source is required
- The maximum applied external voltage is 30V and the maximum sink current is 1A

Function	Description	Output of alarm
AC OK	Signal is 'LOW' when the power supply turns on.	Low or short
	Signal is 'HIGH' when the power supply turns off	High or open (externally applied voltage 1A max.)
BAT. LOW	Signal is 'LOW' when battery voltage is under G:12V, L:22V	Low or short
	Signal is 'HIGH' when battery voltage is above G:12V, L:22V	High or open (externally applied voltage 1A max.)

### AC OK(Battery low)

CN2 Pin1(Pin3)

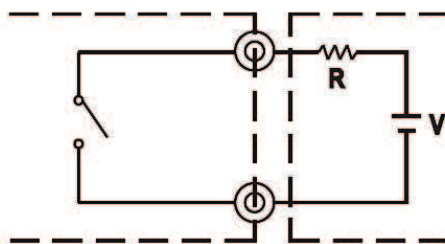

CN2 Pin2(Pin4)

Internal circuit of AC OK (Battery Low)

External voltage source (V) and resistor (R).

Maximum applied voltage is 30V and maximum sink current is 1A