

DPM Series Application Note

Contents

1. Specification
2. Basic Installation
3. System Configuration
 - 3.1 Single Channel Unit
 - 3.2 Dual Channel Unit
4. Setting Instructions
5. Mechanical Details

1. Specification

Input

Voltage Range:
18-32 VDC

Output

Output Voltage:
Input voltage less diode volt drop (0.6 V drop max)

Output Current Rating:
20 A max

DC Low Alarm Set Range:
15 to 26 V (user adjustable)

General

Relay Contacts:
1 pole changeover, 1 A 24 VDC

Screw Terminal Sizes:
Power - suitable for 2.5 mm² cable
Alarm - suitable for 1.0 mm² cable

Mounting:
DIN Rail

Environmental

Operating Temperature:
0 to +50 °C
(+40 °C max ambient plus +10 °C rise inside enclosure)

Storage Temperature:
-40 °C to +85 °C

Humidity:
90% non-condensing

2. Basic Installation

The DPM Series of Diode Protection Modules are designed to be mounted on standard DIN Rail.

Connection is via screw terminals suitable for cable sizes as stated above.

The unit is available in single or dual diode configurations for use in redundant DC power applications.

Incorporated on each module is an input low voltage alarm and customer interface is via a set of volt free contacts for each channel.

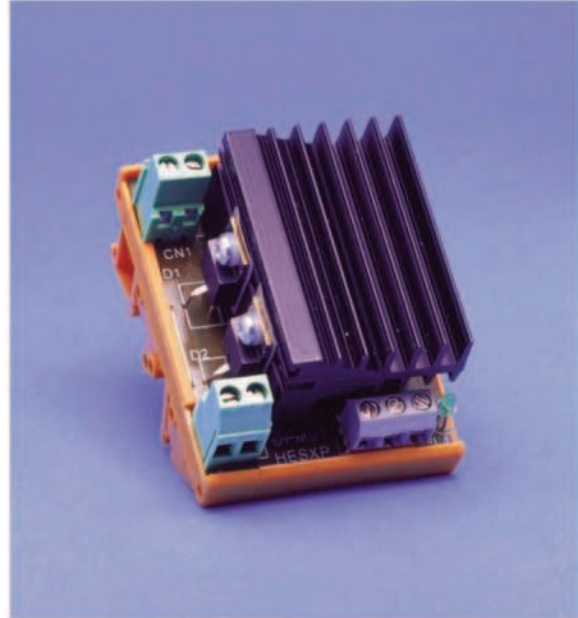

3.0. System Configurations

3.1

Single Channel

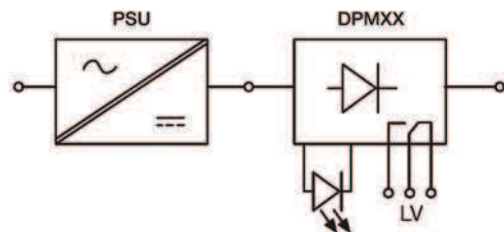

3.2

Dual Channel

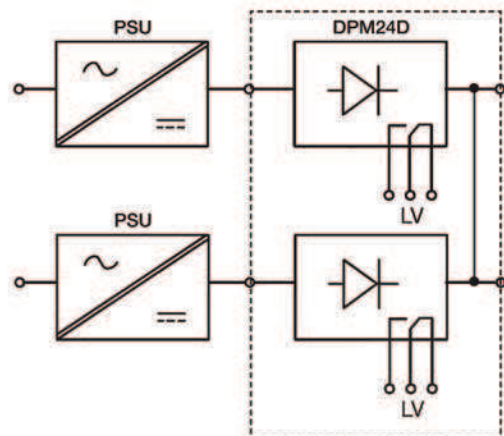

DPM Series Diode Protection Module



www.powersolve.co.uk

4.0. Setting Instructions

Connect unit up as shown in following diagram, using a variable PSU suitable for the module nominal voltage.

1. Adjust supply voltage to system normal voltage level.
2. Turn VR1 on single channel unit or VR1 & VR2 anti-clockwise.
3. Adjust supply voltage to the low voltage alarm level required.
4. Turn VR1 on single channel unit or VR1 & VR2 until low voltage alarm relay de-energises.
5. Adjust supply voltage to normal operating voltage level and check alarm relays energise.
6. Note: There is approx. 1 V hysteresis between the alarm trip and reset levels.

5.0. Mechanical Details

Single Channel (Pre January 2004)

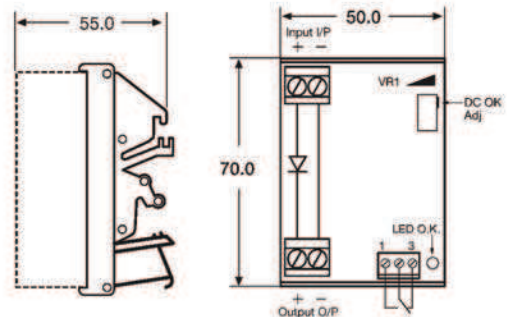

Single Channel (Pre January 2004)

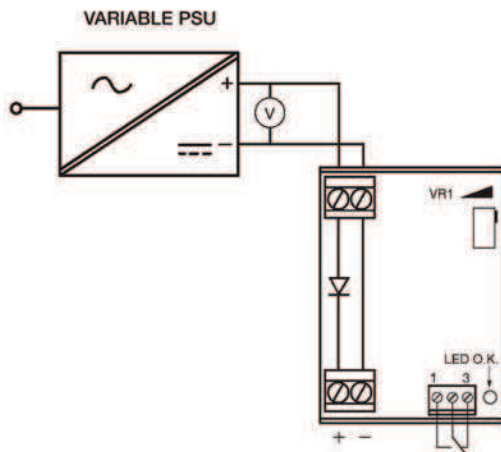

Single Channel (Post January 2004)

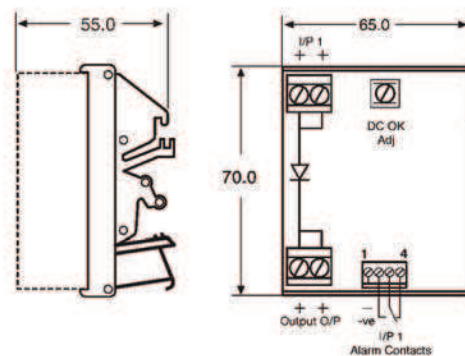

Dual Channel

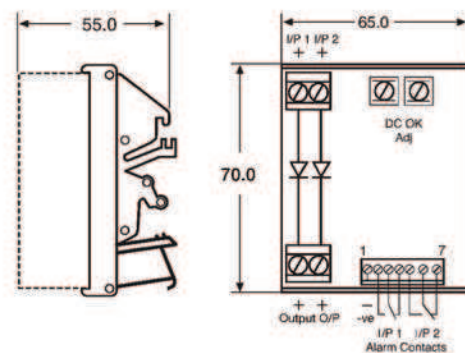

Single Channel (Post January 2004)

