

# INDUSTRIAL POWER SUPPLIES

**POWER  
SOLVE**

[www.powersolve.co.uk](http://www.powersolve.co.uk)

## PDR Series 72-500 Watts Intelligent Monitoring DIN Rail Mounting Power Supplies

### FEATURES:

- Universal AC Input
- Short Circuit Protection with Auto Recovery
- Optional N+1 Redundant Function
- Intelligent Memory displaying Voltage, Current, Temperature & Running Time on Front Panel Display
- Active Power Factor Correction on 120W models & above
- Output Ready Signal



### Electrical Specification

Input:	90-264VAC, 127-380VDC
Input Frequency:	47-63Hz
Inrush Current:	20A @ 110VAC, 40A @ 240VAC
Power Factor Correction:	On 120 to 500W models, 0.95 min
Output Voltage & Current:	See table
Output Adjustment:	+/-10%
Ripple & Noise:	See table
Load Regulation:	±1% 20-100% rated load, ±2% 5V output
Line Regulation:	±1% low line to high line at rated load
Hold Up Time:	16mS, 10mS 500W models
Output Protection:	Short circuit, over current and over voltage protection with auto recovery
Cooling:	72, 120, 200 & 240W models convection cooled, 500W models fan speed controlled
Operating Temperature:	-15°C to +50°C Ambient
Operating Humidity:	5-95% Relative Humidity (Non Condensing)
Vibration:	2G, 10-500Hz, 3 axes
Safety Approvals:	UL/cUL1950, CB Report, CE Marking
EMI/EMC:	EN55022 Class B (Class A for PDR240 & PDR500 Series), EN55024, EN61000-3-2, EN61000-3-3, EN61000-4-2, -4-3, -4-4, -4-5, -4-6, -4-8, -4-11
Mechanical:	See drawings
Connectors:	Screw Terminal Block
Options:	N+1 Redundant Function via Or'ing Diodes, PDR240 has single wire current sharing

### Output Voltage & Current Ratings

Model	Output Voltage	Output Current	Ripple & Noise (pk-pk)	Efficiency (min)
PDR72-05	5V DC	14.4A	70mV	70%
PDR72-12	12V DC	6.0A	100mV	73%
PDR72-24	24V DC	3.0A	150mV	75%
PDR72-48	48V DC	1.5A	250mV	75%
PDR120-12	12V DC	10.0A	100mV	73%
PDR120-24	24V DC	5.0A	150mV	75%
PDR120-48	48V DC	2.5A	250mV	76%
PDR200-12	12V DC	16.6A	100mV	77%
PDR200-24	24V DC	8.3A	250mV	79%
PDR200-48	48V DC	4.2A	250mV	80%
PDR240-12	12V DC	20.0A	100mV	78%
PDR240-24	24V DC	10.0A	150mV	80%
PDR240-48	48V DC	5.0A	250mV	80%
PDR500-12	12V DC	41.6A	100mV	78%
PDR500-24	24V DC	20.8A	150mV	80%
PDR500-48	48V DC	10.4A	250mV	82%

# INDUSTRIAL POWER SUPPLIES



[www.powersolve.co.uk](http://www.powersolve.co.uk)

## Ready Connection:

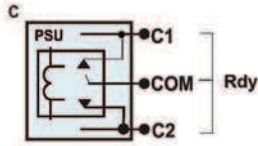

## Options:

Add following suffix after part numbers for option:

R = Redundant Function

## Mechanical Details:

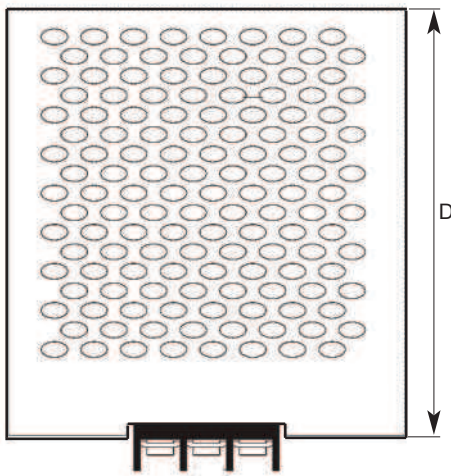

Dimensions (mm)	PDR72	PDR120	PDR200	PDR240	PDR500
D	110	110	110	110	110
H	100	100	100	100	109.5
W	60	90	90	120	210

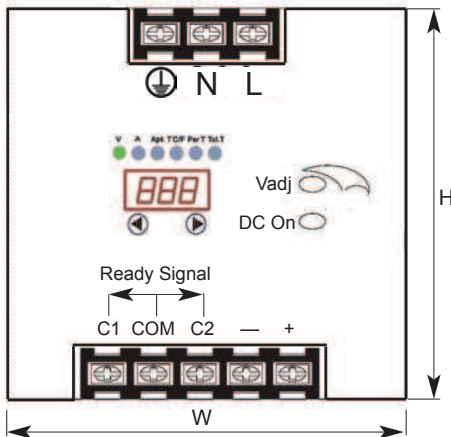

## Connection Details

N	Neutral Terminal no Polarity when DC Input
L	Line Terminal no Polarity when DC Input
⊕	Grounding Earth Terminal
COM	DC OK Output Signal, 10A Relay 1A Current Rating
C1	Normally Closed Connection
C2	Normally Open Connection
-	DC Negative Output Terminal
+	DC Positive Output Terminal
Vadj	Potentiometer for Output Voltage Adjust
DC ON	Green LED Indicator showing Output Present
Cs	Current Share Signal (PDR240 only)



Output Connector for PDR240 Series

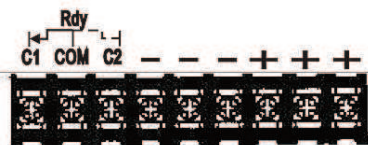

Output Connector for PDR500 Series

Case Material: Aluminium  
Colour: Aluminium

## Instructions for Intelligent Memory Function

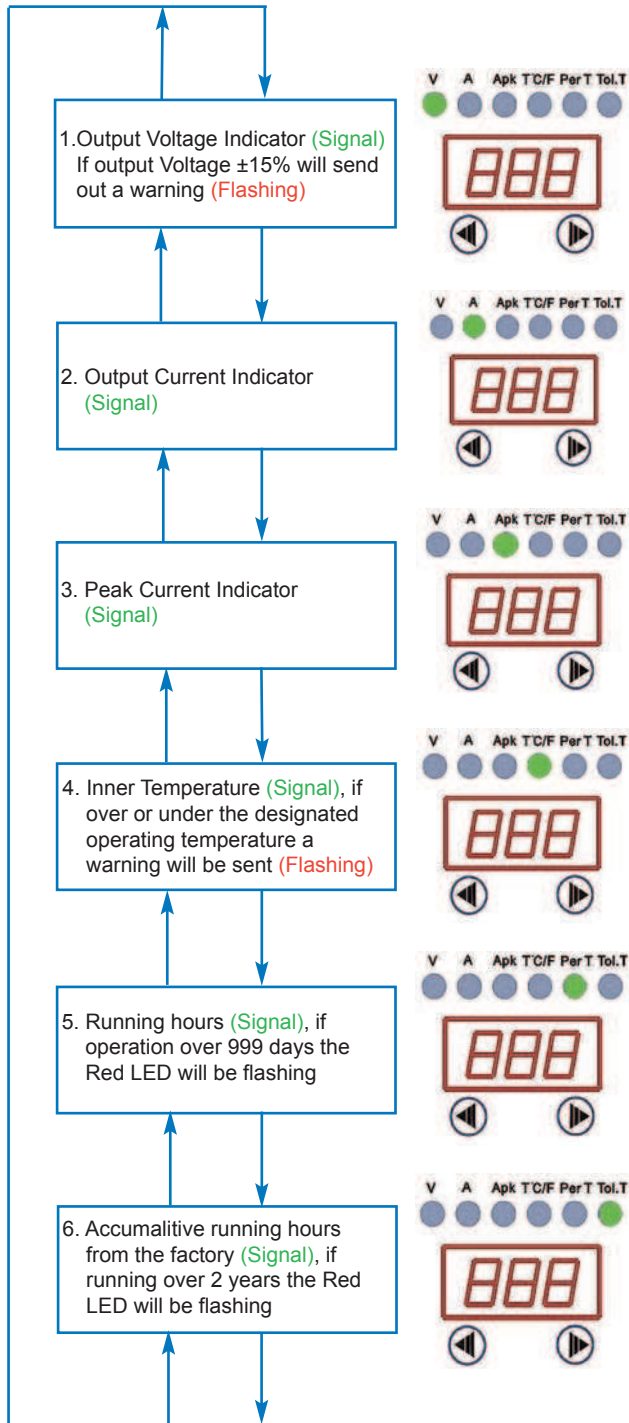

1. Dual LED, when **Green LED** is on it shows the output voltage. If the **Red LED** is flashing it means the voltage is more than  $\pm 15\%$  of V out. It will show the output voltage and send a warning signal via Ready Relay which will change from COM to C2 (output OK) to COM to C1 (fault)

2. Single LED, **Green LED** on shows the output current. When LED flashing means the output current is over the rating and will signal a warning (Rdy Signal) as in 1. above

3. Single LED, **Green LED** on shows the peak current which is approximately over 50mSec. To reset the peak output current press the two arrows simultaneously and hold for more than one second to reset to zero. After release it will measure again over 50mSec period and do this continuously.

4. Dual LED, **Green LED** on indicates degrees C and press **▶ Red LED** on to indicate degrees F, this shows internal temperature. When **Red LED** is flashing this indicates that the temperature is under  $-20^{\circ}\text{C}/-4^{\circ}\text{F}$  or over  $+70^{\circ}\text{C}/+158^{\circ}\text{F}$  and this will signal a warning (Rdy Signal) as in 1. above

5. Dual LED, **Green LED** on indicates the accumulated running time from switch on in days or press **▶ Red LED** on to show the running time in years. If this is over 999 days or 2.73 years **Red LED** will flash and indicate a signal warning (Rdy Signal). Pressing **◀** and **▶** simultaneously for 3 seconds or powering off will reset the timer.

6. Dual LED, **Green LED** on indicates the accumulated running time since leaving the factory measured in days, or press **▶ Red LED** on to indicate time in hours. This period is recorded regardless of powering on and off. Once the total accumulated running time is over 730 days or 2 years the **Red LED** will flash and indicate a signal warning (Rdy Signal). This can be reset by pressing **◀** and **▶** simultaneously for 3 seconds or powering off will reset the timer