

# 1500 Watts

## GFR Series



- 1U Blind-Mate, Hotswap, Redundant
- All Models Share Same Compact Size
- 56 V Power Over Ethernet Compatible Model
- Up to 6 kW in 1U (Rack Available)
- AC OK, DC OK, Inhibit, Enable, 5 V Standby
- Current Share & I<sup>2</sup>C Interface
- 3 Year Warranty

## Specification

### Input

Input Voltage	• 85-264 VAC, see derating curve
Input Frequency	• 47-63 Hz
Input Current	• 13 A/6.5 A typical at 115/230 VAC
Inrush Current	• 35 A maximum at 264 VAC
Power Factor	• >0.9
Earth Leakage Current	• 1.5 mA max 264 VAC 60Hz
Input Protection	• Internal T20 A/250 V fuse in line and neutral

### Output

Output Voltage	• See model table
Output Voltage Trim	• Via potentiometer, see model table
Initial Set Accuracy	• ±1% of nominal with 50% load
Minimum Load	• No minimum load required
Line Regulation	• ±0.5% maximum
Load Regulation	• V1: ±0.5%, V2: ±5%
Start Up Delay	• 1 s typical
Over/Undershoot	• 0.5% typical
Transient Response	• 4% deviation, recovery to within 2% in 500 µs for 50-75-50% load change
Ripple & Noise	• 24-56 V models: 1% max pk-pk 12 V models: 2% max pk-pk V Standby: 3% max pk-pk, 20 MHz bandwidth
Overvoltage Protection	• 115-140% of V1 nominal, recycle input AC to reset
Overtemperature Protection	• Protects the unit against overtemperature. Auto restart
Overcurrent Protection	• 110 - 140% V1, V Standby power limited
Short Circuit Protection	• Continuous, trip and restart (hiccup mode)
Temperature Coefficient	• 0.02%/°C (after 20 minute warm up)
Remote Sense	• Compensates for 0.5V total drop
Current Share	• Share up to 8 units maximum, units share current within 10% of each other at full load.

### General

Efficiency	• 90% typical
Isolation	• 3000 VAC Input to Output, 4000 VAC Input to Output (48-56 V) 1500 VAC Input to Ground, 500 VDC Output to Ground 1500 VAC Output to Ground (48-56 V)
Switching Frequency	• 70 kHz PFC typical, 130 kHz main converter typical
Power Density	• 18 W/in <sup>3</sup>
Signals	• AC OK, DC OK, Inhibit, Enable, I <sup>2</sup> C (see Signals page 3 & 4)
MTBF	• 470 Khrs to TELECORDIA SR-332, 25 °C, GB

### Environmental

Operating Temperature	• -20 °C to +70 °C, derate linearly from +50 °C at 2.5 %/°C to 50% load at +70 °C
Cooling	• Internal load dependant variable speed fans
Operating Humidity	• 95% RH, non-condensing
Storage Temperature	• -40 °C to +85 °C
Operating Altitude	• 3000 m
Shock	• ±3 shocks in each axis (total 18 shocks) 30 g 11 ms (half sine). Compliant with EN60068-2-27.
Vibration	• 2 g 10-500 Hz 10 sweeps. Compliant with EN60068-2-6.

### EMC & Safety

Emissions	• EN55022 class A conducted & radiated <sup>(1)</sup>
Immunity	• Compliant with EN61204-3:2000 high severity levels
Harmonic Currents	• EN61000-3-2 class A EN61000-3-2 class C for loads >20%
Voltage Flicker	• EN61000-3-3
ESD Immunity	• EN61000-4-2, level 3, Perf Criteria A
Radiated Immunity	• EN61000-4-3, level 3 Perf Criteria A
EFT/Burst	• EN61000-4-4, installation class 3, Perf Criteria A
Surge	• EN61000-4-5, level 3 Perf Criteria A
Conducted Immunity	• EN61000-4-6, level 3, Perf Criteria A
Dips & Interruptions	• EN61000-4-11, 30% 10 ms, 60% 100 ms, 100% 5000 ms, Perf Criteria A, B, B. Semi F47 Compliant.
Safety Approvals	• IEC60950-1: CB Report, CSA-C22.2 No. 60950-1-05, UL60950-1, TUV EN60950-1.

### Notes

1. Contact sales for class B conducted emissions performance.



Output Power	Output Voltage V1	Voltage Adj V1	Output Current V1		Standby Supply V2	Model Number
			90-264 VAC	>180 VAC		
1200 W	12.0 VDC	11-14 V	100 A	100 A	5 V/1 A	GFR1K5PS12
1500 W	24.0 VDC	22-28 V	50 A	63 A	5 V/1 A	GFR1K5PS24
1500 W	48.0 VDC	45-52 V	25 A	31 A	5 V/1 A	GFR1K5PS48
1500 W	56.0 VDC	54-59 V	22 A	27 A	5 V/1 A	GFR1K5PS56

**Mechanical Details**

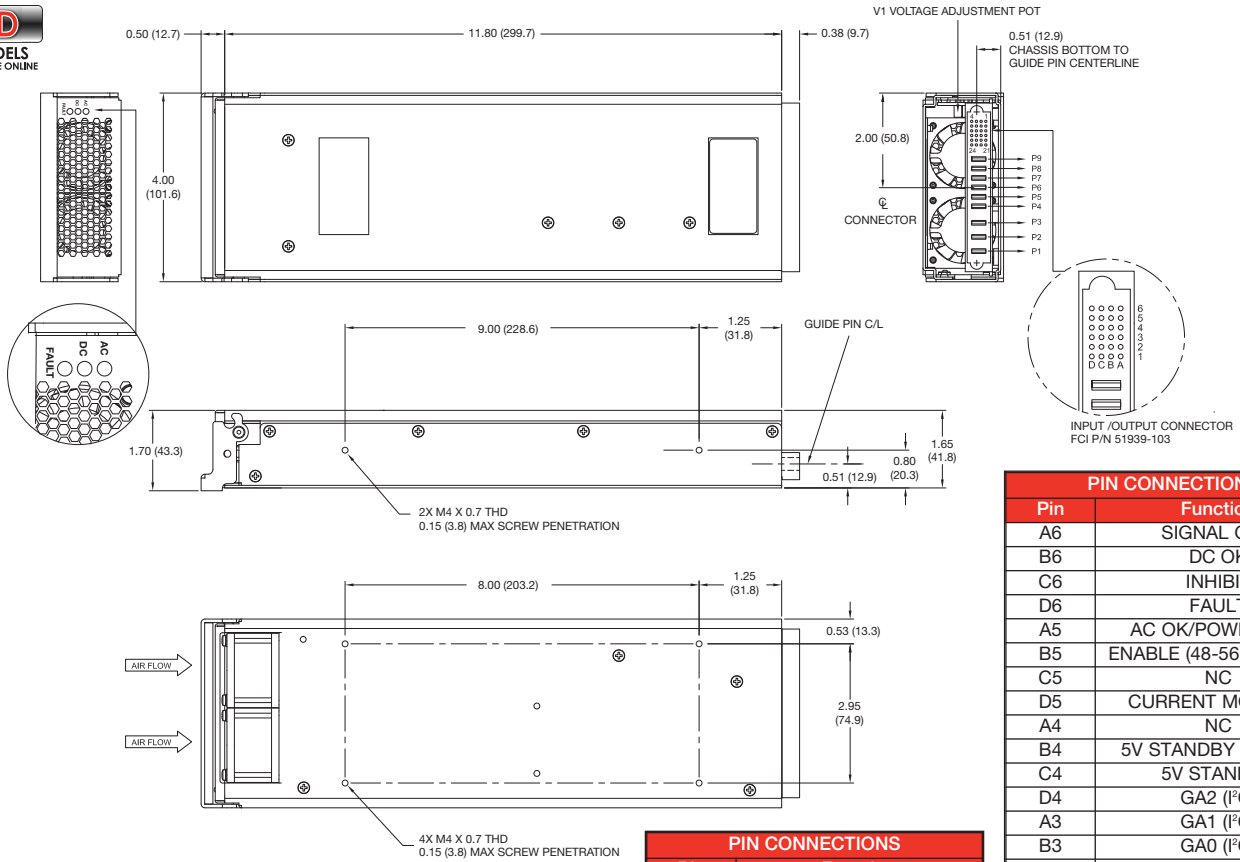

PIN CONNECTIONS	
Pin	Function
A6	SIGNAL GND
B6	DC OK
C6	INHIBIT
D6	FAULT
A5	AC OK/POWER FAIL
B5	ENABLE (48-56 V models)
C5	NC
D5	CURRENT MONITOR
A4	NC
B4	5V STANDBY RETURN
C4	5V STANDBY
D4	GA2 (I <sup>2</sup> C)
A3	GA1 (I <sup>2</sup> C)
B3	GA0 (I <sup>2</sup> C)
C3	I <sup>2</sup> C GND
D3	PMB SDA (DATALINE)
A2	PMB SCL (CLOCK)
B2	PWR ID
C2	V TRIM
D2	ENABLE (12-24 V models)
A1	CURRENT SHARE
B1	NC
C1	- SENSE
D1	+ SENSE

PIN CONNECTIONS	
Pin	Function
P1	AC NEUTRAL
P2	AC LINE
P3	CHASSIS GND
P4	-VOUT
P5	-VOUT
P6	-VOUT
P7	+VOUT
P8	+VOUT
P9	+VOUT

**Notes**

- All dimensions are in inches (mm).  
Tolerance X.XX = ±0.02 (0.50); X.XXX = ±0.01 (0.25)
- Weight 5.2 lb (2.35 kg).
- Output connector: BERG/FCI P/N 51939-103LF  
Mating connector: BERG/FCI P/N 51866-025LF right-angle PCB receptacle

**Derating Curves**

**Input Derating Curve**

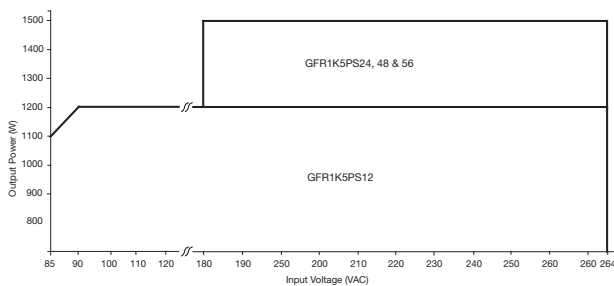

**Thermal Derating Curve**

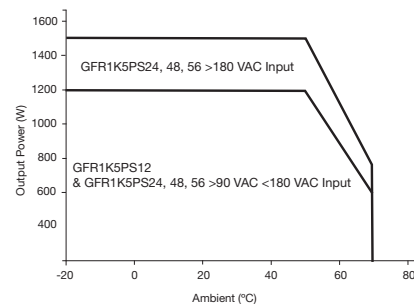

**AC OK/Power Fail**

AC OK is an isolated signal providing a minimum of 5 ms warning of loss of output regulation. The signal is fully isolated and the collector and emitter must be connected externally.

Maximum sink current 2 mA, maximum voltage 20 V.

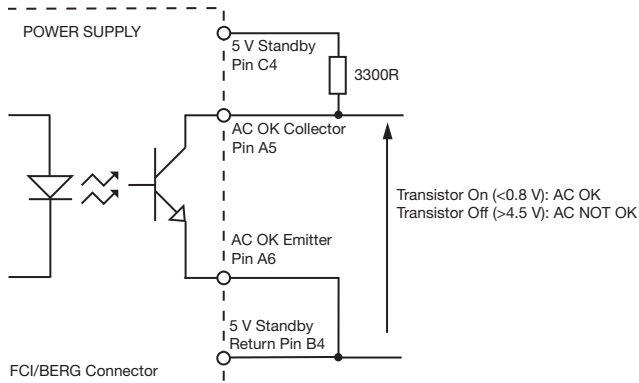

**DC OK**

DC OK is an isolated signal providing warning that the output voltage has fallen below 90% of nominal. The signal is fully isolated and the collector and emitter must be connected externally.

Maximum sink current 2 mA, maximum voltage 20 V.

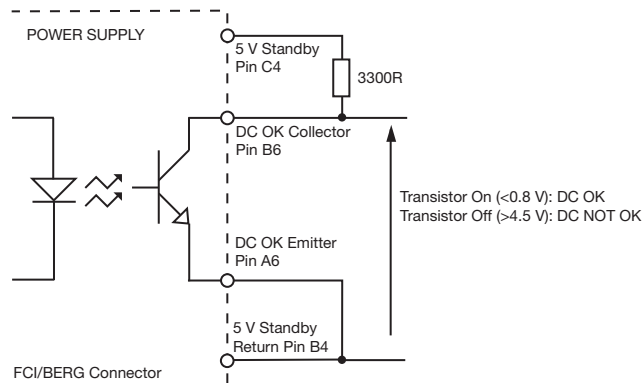

**Inhibit**

Inhibit is an isolated control signal which can turn the power supply off by supplying 2 to 5 mA into the pin.

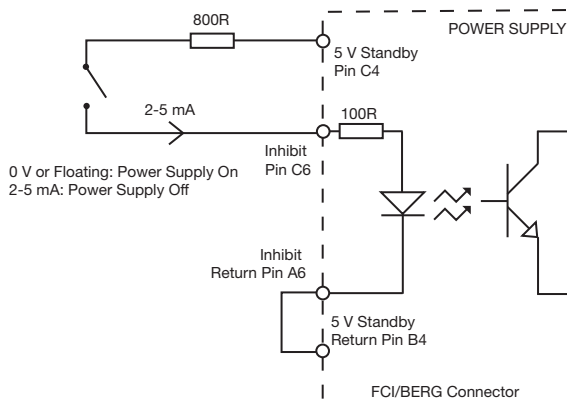

**Fault**

Fault is an isolated signal providing warning of either Power Fail, DC Fail, Fan Fault or Overtemperature. The signal is fully isolated and the collector and emitter must be connected externally.

Maximum sink current 2 mA, maximum voltage 20 V.

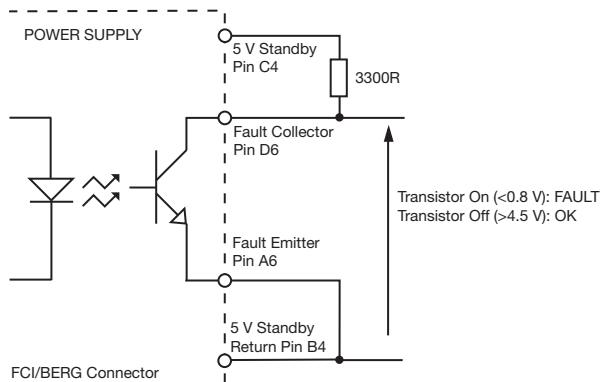

**V Program**

V Program allows remote voltage adjustment within the range  $\pm 10\%$

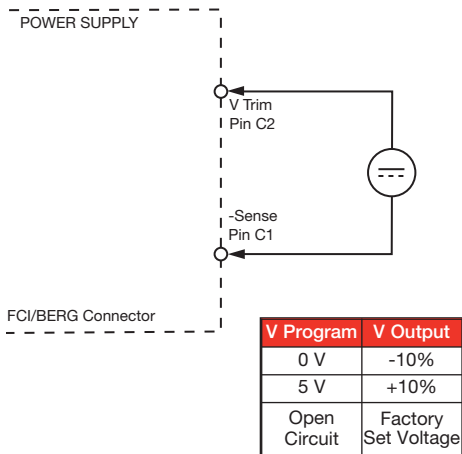

**Current Monitor**

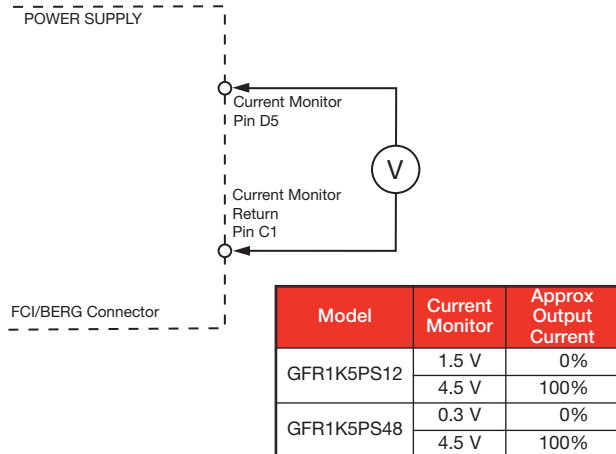

**Current Share**

Connecting pins A1 and C1 of like voltage units (16 maximum) will force the current to share between the outputs. Units share current within 10% of each other at full load. Derate output to 90% of total combined load.

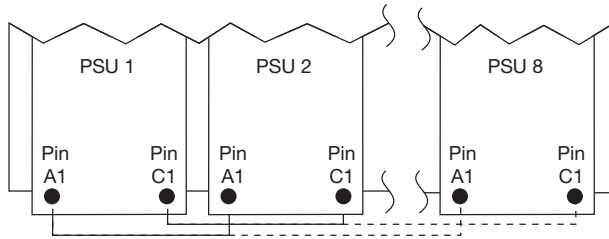

**Enable**

The enable pin D2 (12-24 V models) or B5 (48-56 V models) is shorter than the other pins and mates last, so that the unit does not power up until the connector is mated correctly connecting pin D2 to -Sense pin C1 thus avoiding connector arcing and premature ageing.

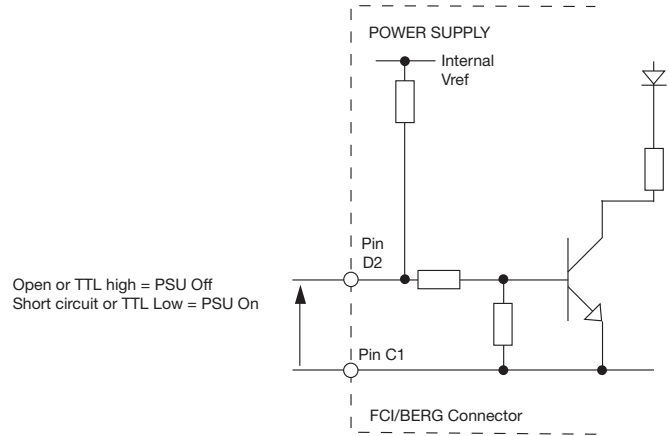

**Power ID**

The power ID pin B2 can be used to detect the presence of the unit when fitted in a rack.

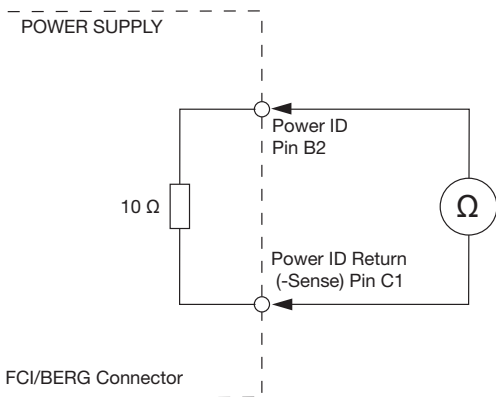

**I<sup>2</sup>C Interface**

The I<sup>2</sup>C PMBus compatible interface can be used for monitoring the output voltage, current, internal temperature and run time. It can also be utilized to turn the unit on and off, detect faults along with identification of the unit model number and serial number.

A separate handbook detailing the use of this interface including comprehensive application notes is available, please contact sales for details.



**GFR1K5 Rack**

A standard 1U 19" Rack is also available which has space for 4 GFR's (6 kW) along with I/O connections for power, signals & control. The standard rack is easily customized to suit customer specific requirements.

Consult handbook for full information.