



[Zoom in Picture](#)

■ Features

- ARM9 166MHz
- 64MB SDRAM, 4MB Flash
- 1 x internal microSD Slot
- 1 x CF-Slot (True IDE mode)
- 2 x USB 2.0 Host
- 1 x Serial Port RS232/422/485
- 1 + 4x Switch Fast Ethernet Auto-MDI(X)
- 8 x Digital-I/O
- 1 x I²C
- 1 x MiniPCI-Slot for WLAN 802.11b/g
- 1 x Console Port
- Very small, fanless, low Power
- Ready-to-run full-featured Debian GNU/Linux platform, Kernel 2.6.35
- Ready-to-run OpenWrt installation
- FTP upload of applications
- RedBoot Boot-Partition
- DIN RAIL mountable
- Starter kits available

Alekto LAN

[Quick Link:](#) | [Features](#) | [Overview](#) | [Application](#) | [Appearance](#) | [System](#) | [Digital I / O](#) | [Serial Interface](#) | [LEDs](#) | [Power Requirements](#) | [Mechanical](#) | [Environmental](#) | [Approvals](#) | [Software Specifications](#) | [Software Development](#) | [Device Drivers](#) | [Ordering Information](#) |

■ Overview

The OnRISC Alekto LAN is an ARM9-based RISC industrial embedded computer. The great variety of interfaces like LAN (with integrated switching hub), CF, USB, I²C, serial interface, digital I/O makes it easy to connect various industrial devices to the OnRISC.

Compact dimensions and DIN Rail mounting capability make the OnRISC to a space saving and flexible mounting industrial computer. It is feasible to be installed even in space limited environments. The internal microSD slot protects the system software against accidentally removal. The integrated switching hub provides connection for more devices with just one uplink cable. Due to RISC based architecture the OnRISC has very small power consumption, so fanless heat dissipation is possible. Working in a wide temperature range from -10°C up to 65°C the OnRISC can be applied in under harsh industrial conditions. Therefore the OnRISC is downright designed for industrial automation.

The embedded computer runs full-featured Debian GNU/Linux on ARM operating system Kernel 2.6. This system is installable on a microSD card to place in the internal card-reader, or on a CF card. With Debian's repository database it is easy to install and update the free software on the OnRISC. The OnRISC is capable to act directly as a software development host, WEB, Mail, Print and Database server or as a desktop computer with X11 window manager and many more. Vision Systems also provides OpenWrt for the Alekto. Read the [News Article...](#)

■ Application

- Building automation system
- Automatic warehouse control system
- Self-service banking system (ATM)
- Wafer fabrication system
- Database server
- Small development host
- Encrypting Router and Firewall
- Remote and distributed serial devices control
- SCADA system
- Industrial / Factory / Laboratory automation
- WEB and Mail server
- Print server
- Small desktop with X11 windows manager and office software

■ Appearance

There are some appearance images of Alekto LAN



Click on the thumbnails to enlarge them ...

[> Back to top](#)

■ System

Processor	ARM9 32-bit RISC CPU, 166MHz
Memory	64MB SDRAM
Flash	4MB BIOS
microSD-Reader	1 x internal as boot device, 7 MB/s SD 2.0 / SDHC
CF-Slot	Type II, True IDE mode (accepts MicroDrives) PIO-0 and PIO-3
LAN	1 x Fast Ethernet Auto-MDI(X) 1 x Fast Ethernet Auto-MDI(X) with integrated 4-port switch
USB	2 x USB 2.0 as Host
Expansion Slot	miniPCI (for WLAN)
Console Port	RS232, up to 115200bps
I²C	max. 330kHz
Time	Real time clock with battery backup (CR2032 in clip)
Other	Buzzer, Watchdog Timer

[> Back to top](#)

■ Digital I / O

Input/ Output	8 Input/Output signals
Signal configuration	Signal direction individually configurable as Input or Output
Electrical	Input: TTL level (0.0 to 0.8V, 2.0 to 5.0V) Output Source: 32mA@TTL High (2.0 to 5.0V) Output Sink: 64mA@TTL Low (0.0 to 0.6V)
IRQ	Maskable IRQ for input signals
Connector type	Terminal block

[> Back to top](#)

■ Serial Interface

Serial Port	1 x RS232/422/485, software selectable Highspeed UART 16C950, 128 Byte FIFO
Available Modes	RS232 RS422 full duplex RS485 4-wire, full duplex RS485 2-wire, half duplex, with echo RS485 2-wire, half duplex, without echo
Signals RS232	TxD,RxD, RTS,CTS, DTR,DSR, DCD, RI, GND
Signals RS422	Tx+/-, Rx+/-, GND
Signals RS485	2-wire: Data+/-, GND 4-wire: Tx+/-, Rx+/-, GND
RS485 Data Direction Control	by ART (Automatic Receive Transmit control) by RTS

Speed

RS232: up to 500 kbps
RS422/485: up to 3.6 Mbps

[> Back to top](#)

■ LEDs

System

Power (red), WLAN connection (blue), IDE (yellow), User (green)

WLAN button

Integrated LED (blue) for WLAN enable

LAN

10M/Link, 100M/Link x 2 integrated in RJ45 connector

Serial

TxD, RxD for each port

[> Back to top](#)

■ Power Requirements

Power Input

9 - 30V DC input

Consumption

max. 1.5A @12V

Connector type

3-pin Power Terminal block

[> Back to top](#)

■ Mechanical

Dimensions

157×106×53 mm³ (W×L×H)
167×112×53 mm³ including DB9 connectors and Terminal block

Weight

0.35kg

Construction Material

Aluminium, 1mm

Mounting

DIN Rail, Wall mounting

[> Back to top](#)

■ Environmental

Operating Temp

-10°C - 65°C

Storage Temp

-20°C - 85°C

[> Back to top](#)

■ Approvals

EMC

FCC Class A, CE Class A

Environment

RoHS

[> Back to top](#)

■ Software Specifications

Linux

Debian GNU/Linux for ARM

Kernel

2.6 (Debian Lenny)
Enhanced support for USB
Watchdog Timer supported

Bootloader

proprietary BIOS to install and boot OS from CF, microSD, USB Mass Storage Devices or over Network

File System

JFFS2 (on-board flash), ext2 (preinstalled system on CF) and many more choices

Protocol Stacks

ARP, PPP, CHAP, PAP, IPv4, ICMP, TCP, UDP, DHCP, FTP, SFTP, SNMP V1/V3, HTTP, HTTPS, NTP, NFS, SMB, SMTP, POP3, IMAP4, SSH 1.0/2.0, SSL, Telnet, PPPoE, OpenVPN, RFC2217

System Utilities

bash, telnet, ping, ftp, ssh, scp, netcat, socat, vim-tiny, e2progs, reiserfs, fdisk

telnetd: Telnet server daemon
vsftpd: FTP server daemon
sshd: Secure shell server daemon
Apache2: Web server daemon

Supporting Services and Daemons

Courier: Mail server daemon
Samba: windows share daemon
sredird: RFC2217
pppd: dial in/out over serial port daemon
openssl: Open SSL
openvpn: virtual private network

Complete Image

Pre-configured OS with applications to install on a 2 GB microSD or CF-card. It consists of
tools gcc-3.3, vim-tiny
services ssh, telnet, vsftpd (each as server and client)
netcat and socat
To speed up the boot process other software packages are not started automatically. To enable them please read the manual.
Packages are:
Samba client and server
Apache2 web server
Courier mail server
NTP client and server
sredird RFC2217 server
WindowMaker desktop
xdm server (X11)
AbiWord
dillo web browser

Router

Pre-configured installation of OpenWrt, to install on SD or CF card.

[> Back to top](#)

■ Software Development

On-board Tool Chain

Gcc, Glibc, gdb, vim-tiny editor, gmake (develop on Alekto)

Linux Tool Chain

Gcc, Glibc, gdb, Insight, gmake (develop on a Linux PC)

Kernel

Kernel 2.6 sources

Hardware

Driver sources for Alekto-specific hardware components

[BuildRoot](#) is a set of Makefiles and patches that allows to easily generate a cross-compilation toolchain, a root filesystem and a Linux kernel image for the target. Buildroot can be used for one or more of these options, independently. The benefits are:

BuildRoot

- No need to supply the toolchain, will be built automatically
- Choice between various file systems for the target image
- Builds a very small and quick booting system that suits the needs
- Drivers compiled as modules will be automatically installed on the file system image
- many more ...

[> Back to top](#)

■ Device Drivers

Data Communication

USB (supports USB Mass Storage Devices, USB-to-Serial converters, USB-CAN adapter, Bluetooth)
UART 16C950, 128 Byte FIFO, RS232/422/485
I²C
WLAN 802.11b/g RaLink cards (RT2561) optional

Others

Digital I/O
RTC
Buzzer
WLAN button
LEDs
Watchdog Timer

■ Ordering Information

Art.No 6804

Product Name OnRISC Alekto LAN

Packing list

OnRISC Alekto LAN

Power supply adapter 12V, 1500mA

Adapter cable for console port

DVD-ROM-1: Debian on ARM

DVD-ROM-2: system images, sources, tools, English documentation

■ Full size product image



[> Back to top](#)

Alekto LAN Top View

[> Back](#)

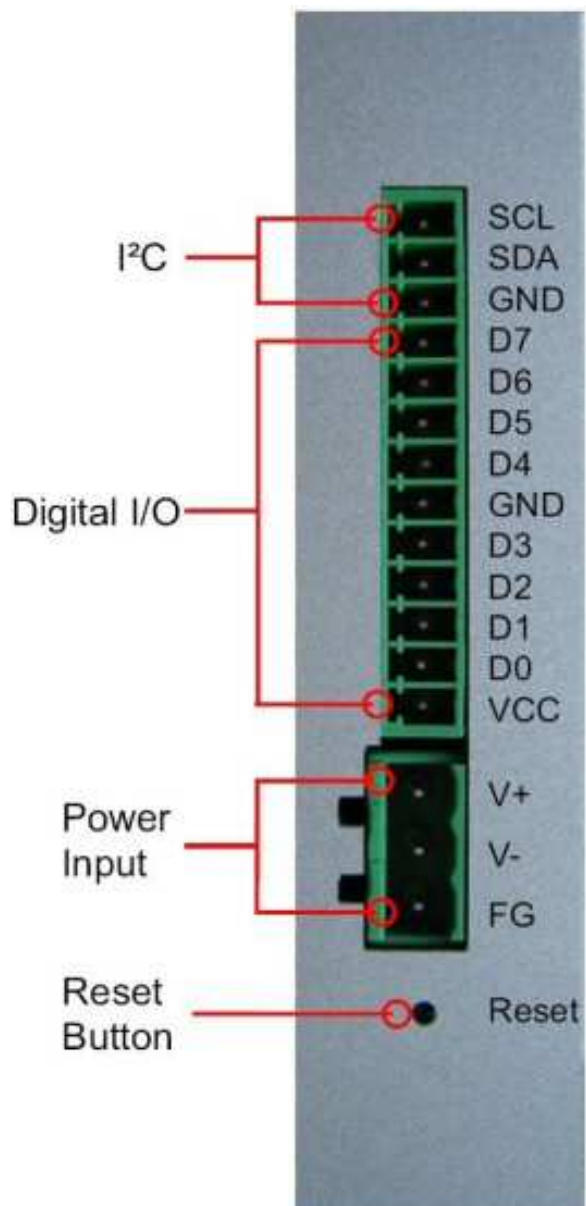

DIN-Rail mounting options

[> Back](#)

