



**GLASS PASSIVATED SILICON RECTIFIER**

**VOLTAGE 200 Volts CURRENT 8.0 Ampere**

**FEATURES**

- \* Low leakage
- \* Low forward voltage drop
- \* High current capability
- \* High surge capability
- \* High reliability

**MECHANICAL DATA**

- \* Case: Slim PAQ
- \* Epoxy: Device has UL flammability classification 94V-0
- \* Lead: MIL-STD-202E method 208C guaranteed
- \* Mounting position: Any

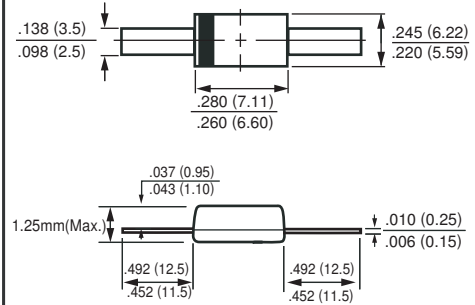
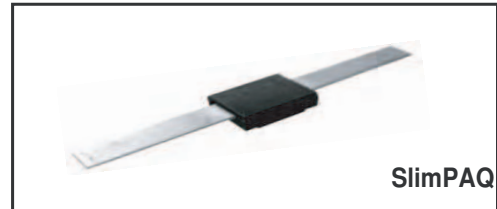

**MAXIMUM RATINGS AND ELECTRICAL CHARACTERISTICS**

Ratings at 25 °C ambient temperature unless otherwise specified.  
resistive or inductive load.

**MAXIMUM RATINGS (@ TA=25 °C unless otherwise noted)**

RATINGS	SYMBOL	SPAC803F	UNITS
Maximum Recurrent Peak Reverse Voltage	$V_{RRM}$	200	Volts
Maximum RMS Voltage	$V_{RMS}$	140	Volts
Maximum DC Blocking Voltage	$V_{DC}$	200	Volts
Maximum Average Forward Rectified Current at $T_C = 125^\circ C$	$I_O$	8.0	Amps
Peak Forward Surge Current 8.3 ms single half sine-wave superimposed on rated load (JEDEC method)	$I_{FSM}$	125	Amps
Typical Current Square Time	$I^2T$	64.8	A <sup>2</sup> S
Typical Thermal Resistance (Note 1)	$R_{\theta JC}$	6.25	°C/W
	$R_{\theta JA}$	12.5	
	$R_{\theta JL}$	3.1	
Typical Junction Capacitance (Note 2)	$C_J$	40	pF
Operating and Storage Temperature Range	$T_J, T_{STG}$	-55 to + 175	°C

**ELECTRICAL CHARACTERISTICS (@TA=25 °C unless otherwise noted)**

CHARACTERISTICS	SYMBOL	SPAC803F	UNITS
Maximum Instantaneous Forward Voltage at 8.0A DC	$V_F$	1.1	Volts
Maximum DC Reverse Current at Rated DC Blocking Voltage	@ $T_A = 25^\circ C$	10	mAmps
	@ $T_A = 100^\circ C$	100	

- NOTES :
1. Thermal Resistance : Heat-sink case mounted or if PCB mounted.
  2. Measured at 1 MHz and applied reverse voltage of 4.0 volts.
  3. "Fully ROHS compliant", "100% Sn plating (Pb-free)".
  4. Suffix "R" for Reverse Polarity.
  5. Available in Halogen-free epoxy by adding suffix -HF after the part nbr.

## RATING AND CHARACTERISTICS CURVES ( SPAC803F )

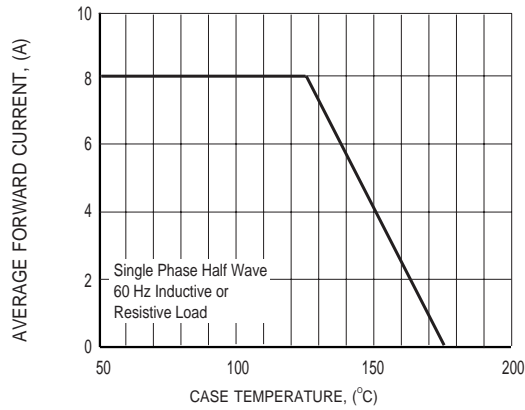

**FIG.1 TYPICAL FORWARD CURRENT DERATING CURVE**

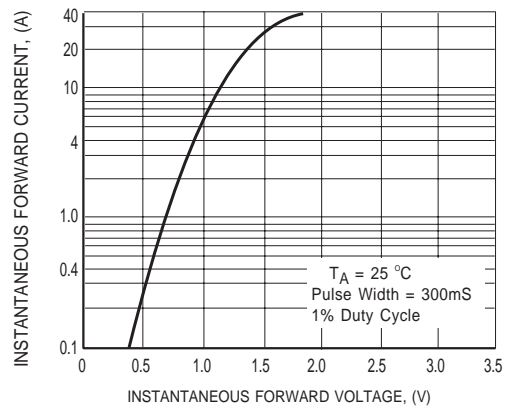

**FIG.2 TYPICAL INSTANTANEOUS FORWARD CHARACTERISTICS**

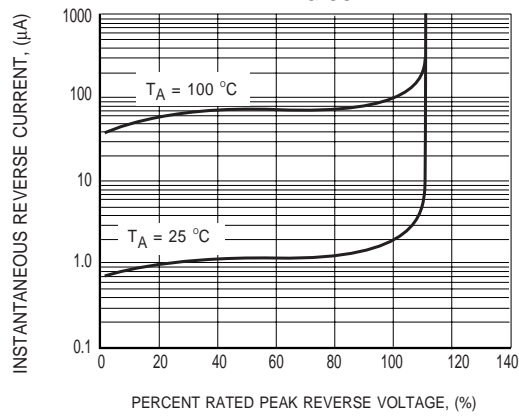

**FIG.3 TYPICAL REVERSE CHARACTERISTICS**

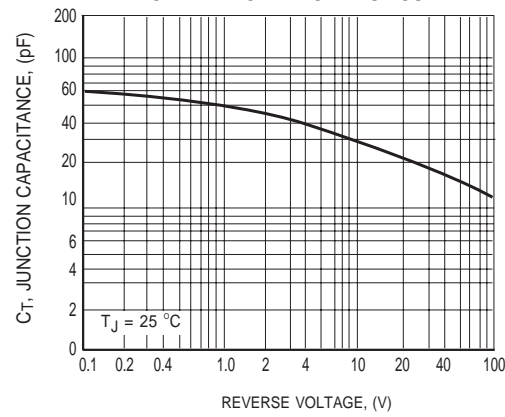

**FIG.4 TYPICAL JUNCTION CAPACITANCE**

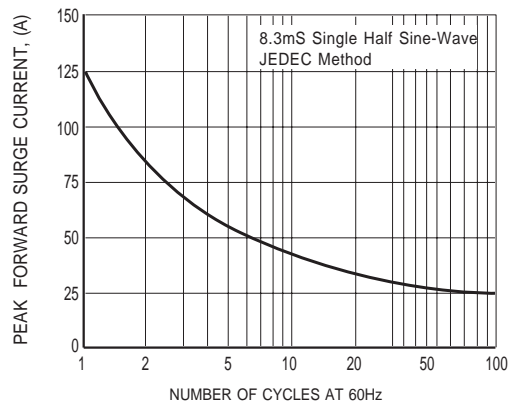

**FIG.5 MAXIMUM NON-REPETITIVE FORWARD SURGE CURRENT**

## DISCLAIMER NOTICE

Rectron Inc reserves the right to make changes without notice to any product specification herein, to make corrections, modifications, enhancements or other changes. Rectron Inc or anyone on its behalf assumes no responsibility or liability for any errors or inaccuracies. Data sheet specifications and its information contained are intended to provide a product description only. "Typical" parameters which may be included on RECTRON data sheets and/ or specifications can and do vary in different applications and actual performance may vary over time. Rectron Inc does not assume any liability arising out of the application or use of any product or circuit.

Rectron products are not designed, intended or authorized for use in medical, life-saving implant or other applications intended for life-sustaining or other related applications where a failure or malfunction of component or circuitry may directly or indirectly cause injury or threaten a life without expressed written approval of Rectron Inc. Customers using or selling Rectron components for use in such applications do so at their own risk and shall agree to fully indemnify Rectron Inc and its subsidiaries harmless against all claims, damages and expenditures.

