

Oak 10V

8 Channels Analog to Digital Converter with Galvanic Isolated $\pm 10V$ Input

Datasheet

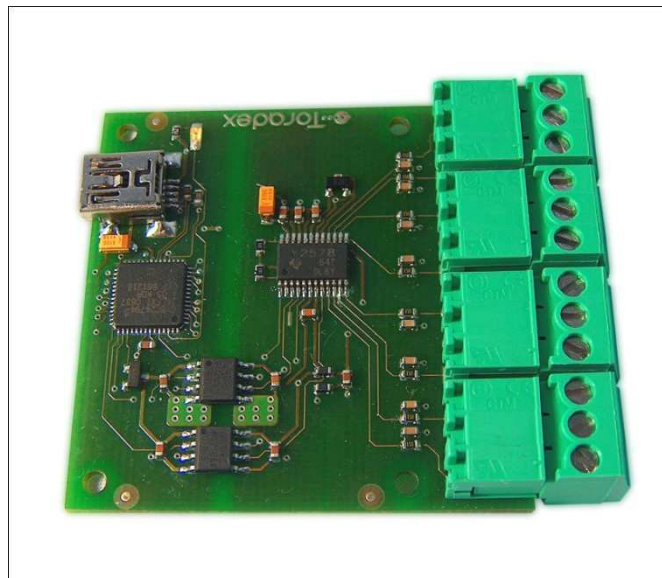

Revision history

Date	Doc. Rev.	Changes
21-Jun-2011	Rev. 1.4	Disclaimer Update
17-Jan-2011	Rev. 1.3	Minor Edits
29-Oct-2010	Rev. 1.2	Added Operating Temperature Range
30-Sep-2010	Rev. 1.1	Added USB Vendor ID and Product ID
28-Feb-2008	Rev. 1.0	Initial Release
22-Oct-2007	Rev. 0.9	Preliminary Release



Contents

1. Introduction	3
1.1 Reference Documents	3
2. Hardware Specifications	4
2.1 Analog to Digital Converter: Texas Instruments TLC2578	4
2.2 Equivalent Input Circuit	4
2.3 Pin Assignment	4
2.4 Supported ADC Features	5
2.5 USB Interface	5
2.6 Operating Temperature Range	5
3. Software Specifications	6
3.1 INTERRUPT IN Report Contents (Real time data)	6
3.2 FEATURE Report Commands	7
4. Technical Specifications	10
4.1 Current Consumption	10
4.2 Mechanical Dimensions	10
4.3 RoHS Compliance	10



1. Introduction

The Oak 10V is a USB attached analog to digital converter board with 8 single-ended channels or 4 pseudo-differential channels. The ADC board can run at a sampling rate of up to 1kHz independent of the number of used channels. Voltages between -10V and +10V can be measured with a resolution of approximately 5mV (12 bit ADC)

The analog inputs are completely isolated from the USB circuit. There is no isolation between the analog input channels because they have a common ground. To simplify installation, the analog inputs feature disconnectable interfaces. The mating connectors have screw terminals to allow for a quick attachment of bare wires.

The Oak 10V can be integrated in a custom application very easily. The operating power as well as real time ADC data and uncritical device configuration data are all transferred through a simple USB cable. The very low power consumption, including automatic entering into sleep mode, allows using the device not only in fixed installation, but also in mobile applications.

1.1 Reference Documents

ADC Datasheet

http://files.toradex.com/Oak/Datasheets/Components/Oak_10V/tlc2578.pdf

Programming Guide to the Oak Sensor Family



2. Hardware Specifications

2.1 Analog to Digital Converter: Texas Instruments TLC2578

The Oak 10V board features Texas Instruments, TLC2578 for digital conversion. For more information, see the original datasheet of the ADC. The following key specifications of the Oak 10V may differ from the datasheet of the ADC.

Analog input range:	-10V minimum +10V maximum
Input impedance:	10k Ω Typical
Input capacitance:	56 nF Typical
Sampling rate:	Maximum 1kHz for every channel
Resolution	12Bit (5mV)

2.2 Equivalent Input Circuit

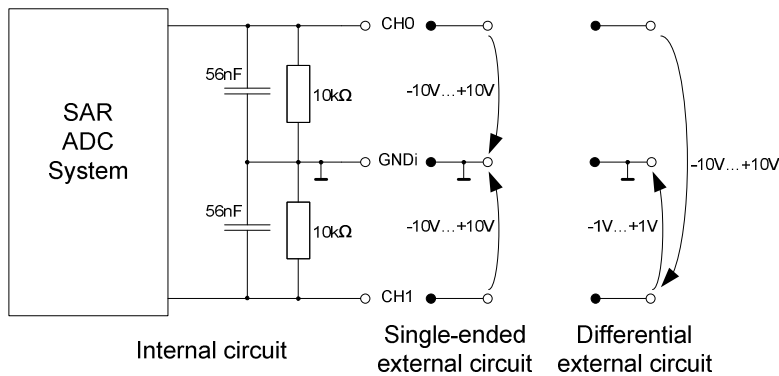

Figure 1: Equivalent input circuit for each channel pair

2.3 Pin Assignment

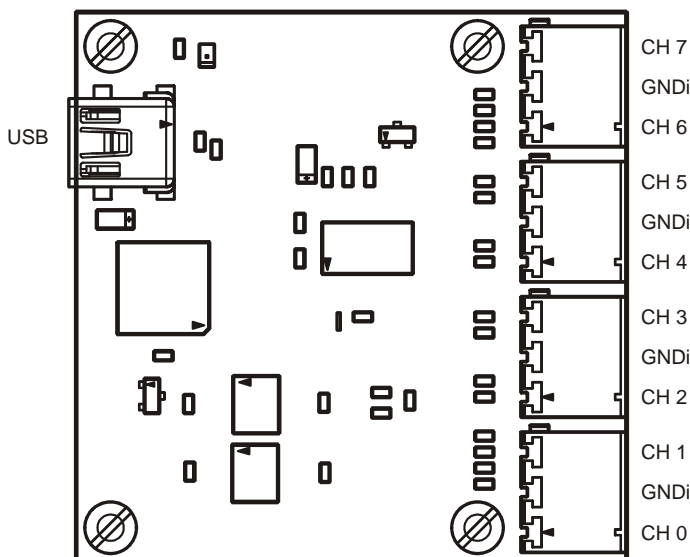

Figure 2: Pin assignment of the Oak 10V device



2.4 Supported ADC Features

Read analog input voltage in Volts

Single-ended or pseudo-differential input selectable

Sample rate adjustable

2.5 USB Interface

Interface: USB 2.0 Full Speed (12Mbits/s)

Connector: Standard USB Mini-B

Device Class: HID

Vendor ID: 0x1B67

Product ID: 0x000E

Update Rate: 1ms to 65s, user adjustable

Report Rate: 1ms to 65s, user adjustable

2.6 Operating Temperature Range

Minimum Operating Temperature: -10°C

Maximum Operating Temperature: +85°C



3. Software Specifications

All Oak Devices are implemented as HID devices. Thus driver support is built into all major operating systems.

The converted analog data is transmitted through an INTERRUPT IN report. Therefore real time processing can be guaranteed. The data can be received by the host using regular file read operation. Chapter 3.1 describes the contents of this report.

On an independent communication channel, device configuration is done using FEATURE reports that are 32 Bytes in length. Special operating system calls exist to transmit / receive feature reports. Chapter 3.2 shows the structure of a feature report for each supported command.

Please refer also to the document "Programming Guide to the Oak Sensor Family" for more details.

3.1 INTERRUPT IN Report Contents (Real time data)

In the single-ended input mode, the INTERRUPT IN report contains the following items:

16 Bit	Frame Number	10^{-3}	s		
16 Bit	Voltage Channel 0	10^{-3}	V	(CH 0 to GNDi)	Signed
16 Bit	Voltage Channel 1	10^{-3}	V	(CH 1 to GNDi)	Signed
16 Bit	Voltage Channel 2	10^{-3}	V	(CH 2 to GNDi)	Signed
16 Bit	Voltage Channel 3	10^{-3}	V	(CH 3 to GNDi)	Signed
16 Bit	Voltage Channel 4	10^{-3}	V	(CH 4 to GNDi)	Signed
16 Bit	Voltage Channel 5	10^{-3}	V	(CH 5 to GNDi)	Signed
16 Bit	Voltage Channel 6	10^{-3}	V	(CH 6 to GNDi)	Signed
16 Bit	Voltage Channel 7	10^{-3}	V	(CH 7 to GNDi)	Signed

In the pseudo-differential input mode, the INTERRUPT IN report contains the following items:

16 Bit	Frame Number	10^{-3}	s		
16 Bit	Voltage Channel 0 to 1	10^{-3}	V	(CH 0 to CH 1)	Signed
16 Bit	Voltage Channel 1 to 0	10^{-3}	V	(CH 1 to CH 0)	Signed
16 Bit	Voltage Channel 2 to 3	10^{-3}	V	(CH 2 to CH 3)	Signed
16 Bit	Voltage Channel 3 to 2	10^{-3}	V	(CH 3 to CH 2)	Signed
16 Bit	Voltage Channel 4 to 5	10^{-3}	V	(CH 4 to CH 5)	Signed
16 Bit	Voltage Channel 5 to 4	10^{-3}	V	(CH 5 to CH 4)	Signed
16 Bit	Voltage Channel 6 to 7	10^{-3}	V	(CH 6 to CH 7)	Signed
16 Bit	Voltage Channel 7 to 6	10^{-3}	V	(CH 7 to CH 6)	Signed



3.2 FEATURE Report Commands

3.2.1 Report Mode

Byte#	0	1	2	3	4	5
Content	GnS	Tgt	0x01	0x00	0x00	RPTMODE

GnS:	0	= Set
	1	= Get
Tgt	0	= RAM
	1	= Flash
RPTMODE:	0	= After Sampling (Factory Default)
	1	= After Change
	2	= Fixed Rate

3.2.2 LED Mode

Byte#	0	1	2	3	4	5
Content	GnS	Tgt	0x01	0x01	0x00	LEDMODE

GnS:	0	= Set
	1	= Get
Tgt	0	= RAM
	1	= Flash
LEDMODE:	0	= Off (Factory Default)
	1	= On
	2	= Blink Slowly
	3	= Blink Fast
	4	= Blink 4 pulses

3.2.3 Report Rate

Number of milliseconds between two IN reports. This parameter will only be regarded if Report Mode = 2 (fixed rate)

Byte#	0	1	2	3	4	5	6
Content	GnS	Tgt	0x02	0x00	0x00	RptRate LSB	RptRate MSB

GnS:	0	= Set
	1	= Get
Tgt	0	= RAM
	1	= Flash
RptRate:	Report Rate [ms]	



Oak 10V Datasheet

3.2.4 Sample Rate

This is the actual sample rate the ADC is working on. If Report Mode = 0 (After Sampling) this is also the rate at which the device reports values to the host PC.

Byte#	0	1	2	3	4	5	6
Content	GnS	Tgt	0x02	0x01	0x00	SampRate LSB	SampRate MSB

GnS: 0 = Set
 1 = Get

Tgt 0 = RAM
 1 = Flash

SampRate: Sample Rate [ms]

3.2.5 User Device Name

Byte#	0	1	2	3	4	5-25
Content	GnS	Tgt	0x15	0x00	0x00	UsrDevName

GnS: 0 = Set
 1 = Get

Tgt 0 = RAM
 1 = Flash

UsrDevName: User defined name for the whole device
 Null-terminated string, max. 20+1 characters

3.2.6 User Channel Name

Byte#	0	1	2	3	4	5-25
Content	GnS	Tgt	0x15	ChP1	0x00	UsrChName

GnS: 0 = Set
 1 = Get

Tgt 0 = RAM
 1 = Flash

ChP1 1 = Channel 0 (Frame Number)
 2 = Channel 1 (ADC Channel 0)
 3 = Channel 2 (ADC Channel 1)
 4 = Channel 3 (ADC Channel 2)
 5 = Channel 4 (ADC Channel 3)
 6 = Channel 5 (ADC Channel 4)
 7 = Channel 6 (ADC Channel 5)
 8 = Channel 7 (ADC Channel 6)
 9 = Channel 8 (ADC Channel 7)

UsrChName: User defined name for the channel
 Null-terminated string, max. 20+1 characters



Oak 10V Datasheet

3.2.7 Input Mode

Byte#	0	1	2	3	4	5
Content	GnS	Tgt	0x01	0x02	0x00	Input Mode

GnS: 0 = Set
 1 = Get

Tgt 0 = RAM
 1 = Flash

Input Mode: 0 = Single-Ended (Factory Default)
 1 = Pseudo-Differential

3.2.8 Offset Channel x

Sets the absolute offset of the channel x

Byte#	0	1	2	3	4	5	6
Content	GnS	Tgt	0x02	ChP3	0x00	Offset LSB	Offset MSB

GnS: 0 = Set
 1 = Get

Tgt 0 = RAM
 1 = Flash

ChP3 3 = Offset ADC Channel 0
 4 = Offset ADC Channel 1
 5 = Offset ADC Channel 2
 6 = Offset ADC Channel 3
 7 = Offset ADC Channel 4
 8 = Offset ADC Channel 5
 9 = Offset ADC Channel 6
 10 = Offset ADC Channel 7

Offset: Absolute offset [mV]



4. Technical Specifications

4.1 Current Consumption

Symbol	Parameter	Conditions	Min	Typ	Max	Unit
I_q	Operating current				150	mA
I_{Stby}	Standby current	No USB activity			500	μ A

4.2 Mechanical Dimensions

The PCB is designed to be mounted using four standard M2 screws. There are no components on the back side of the PCB, but there are through-hole components on top.

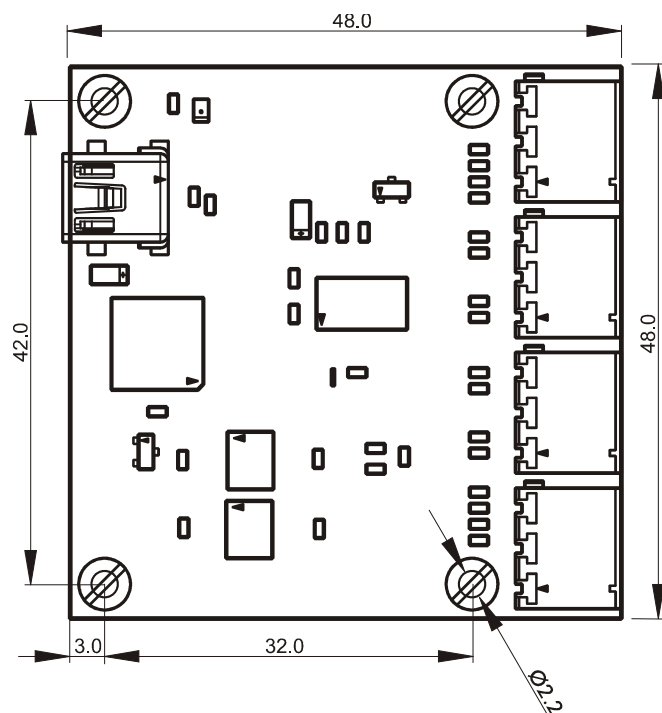

Figure 3: Mechanical dimensions of the Oak 10V device

4.3 RoHS Compliance

Unless otherwise stated, all Toradex products comply with the European Union's Directive 2002/95/EC: "Restrictions of Hazardous Substances".



Disclaimer:

Copyright © Toradex AG. All rights reserved. All data is for information purposes only and not guaranteed for legal purposes. Information has been carefully checked and is believed to be accurate; however, no responsibility is assumed for inaccuracies.

Brand and product names are trademarks or registered trademarks of their respective owners. Specifications are subject to change without notice.