

# Oak MagR

## Magnetic Rotational Encoder

# Datasheet



### Revision history

Date	Doc. Rev.	Changes
21-Jun-2011	Rev. 1.5	Disclaimer Update
17-Jan-2011	Rev. 1.4	Modified Sample Rate Range
29-Oct-2010	Rev. 1.3	Added Operating Temperature Range
29-Sep-2010	Rev. 1.2	Added USB Vendor ID and Product ID
29-Feb-2008	Rev. 1.1	Minor Edits (section 1.1; 3.1 and 3.2.6)
01-Mai-2007	Rev. 1.0	Initial Release



# Contents

<b>1. Introduction</b>	<b>3</b>
1.1 Reference Documents	3
<b>2. Hardware Specifications</b>	<b>4</b>
2.1 Sensor: Austria Microsystems AS5046	4
2.2 Measurement Range	4
2.3 Supported Sensor Features	4
2.4 USB Interface	4
2.5 Operating Temperature Range	4
<b>3. Software Specifications</b>	<b>5</b>
3.1 INTERRUPT IN Report Contents (Real time data)	5
3.2 FEATURE Report Commands	5
<b>4. Technical Specifications</b>	<b>10</b>
4.1 Electrical Specifications	10
4.2 Mechanical Dimensions	10
4.3 RoHS Compliance	10



# 1. Introduction

---

The Oak MagR is a contactless magnetic angle encoder for accurate measurement up to 360° at a resolution of 12 bits. The output is proportional to the angle of a magnet, rotating over the chip. In addition, the USB interface enables a user configurable arrangement of the Hall array and allows access to each individual Sensor of the Hall Array.

The Oak MagR also provides high resolution information of the magnetic field strength, respectively the vertical distance of the magnet, thus adding excellent state-of-health information of the overall system.

The Oak MagR can be integrated in a custom application very easily. The operating power as well as real time sensor data and uncritical sensor configuration data are all transferred through a simple USB cable. The very low power consumption, including automatic entering into sleep mode, allows using the device not only in fixed installations, but also in mobile applications.

## 1.1 Reference Documents

Sensor Datasheet:

[http://files.toradex.com/Oak/Datasheets/Components/Oak\\_Mag\\_R/AS5046\\_Datasheet\\_v1\\_12.pdf](http://files.toradex.com/Oak/Datasheets/Components/Oak_Mag_R/AS5046_Datasheet_v1_12.pdf)

Programming Guide to the Oak Sensor Family



## 2. Hardware Specifications

### 2.1 Sensor: Austria Microsystems AS5046

The AS5046 is a contactless magnetic rotary encoder for accurate angular measurement over a full turn of 360°.

To measure the angle, only a simple two-pole magnet, rotating over the center of the chip, is required. The absolute angle measurement provides instant indication of the magnet's angular position with a resolution of  $0.0879^\circ = 4096$  positions per revolution.

The AS5046 also provides high resolution information of the magnetic field strength, respectively the vertical distance of the magnet, thus adding excellent state-of-health information of the overall system.

### 2.2 Measurement Range

Angle: 0 - 6.2831 rad (0 – 360°)  
Resolution: 0.0015 rad (0.09°)

For more details, please refer to the sensor datasheet (link in chapter 1.1)

### 2.3 Supported Sensor Features

Read Angle

Read Field Magnitude

Read Status Bits

Read Align Data

Set OTP register

Read / Write I2C accessible registers

Slow Mode / Fast Mode

Sample rate adjustable

### 2.4 USB Interface

Interface: USB 2.0 Full Speed (12Mbit/s)

Connector: Standard USB Mini-B

Device Class: HID

Vendor ID: 0x1B67

Product ID: 0x000B

Sampling Rate: 2ms to 65s, user adjustable

Report Rate: 1ms to 65s, user adjustable

### 2.5 Operating Temperature Range

Minimum Operating Temperature: -10°C

Maximum Operating Temperature: +85°C



## 3. Software Specifications

All Oak Sensors are implemented as HID devices. Thus driver support is built into all major operating systems.

Captured sensor Data is transmitted through an INTERRUPT IN reports. Therefore real time processing can be guaranteed. This data can be received by the host using regular file read operations. Chapter 3.1 describes the contents of this report.

On an independent communication channel, sensor configuration is done using FEATURE reports that are 32 Bytes in length. Special operating system calls exist to transmit / receive feature reports. Chapter 3.2 shows the structure of a feature report for each supported command.

Please refer also to the document "Programming Guide to the Oak Sensor Family" for more details.

### 3.1 INTERRUPT IN Report Contents (Real time data)

16 Bit	Frame Number	$10^{-3}$	s
16 Bit	Angle	$10^{-4}$	rad
16 Bit	Magnitude	-	- (absolute value, only 8 bits used)
16 Bit	Status	-	-
		Bit 4:	OCF
		Bit 3:	COF
		Bit 2:	LIN
		Bit 1:	MAGINC
		Bit 0:	MAGDEC

### 3.2 FEATURE Report Commands

#### 3.2.1 Report Mode

Byte#	0	1	2	3	4	5
Content	GnS	Tgt	0x01	0x00	0x00	RPTMODE

GnS: 0 = Set  
1 = Get

Tgt 0 = RAM  
1 = Flash

RPTMODE: 0 = After Sampling (Factory Default)  
1 = After Change  
2 = Fixed Rate



## Oak MagR Datasheet

### 3.2.2 LED Mode

Byte#	0	1	2	3	4	5
Content	GnS	Tgt	0x01	0x01	0x00	LEDMODE

GnS: 0 = Set  
1 = Get

Tgt 0 = RAM  
1 = Flash

LEDMODE: 0 = Off (Factory Default)  
1 = On  
2 = Blink Slowly  
3 = Blink Fast  
4 = Blink 4 pulses

### 3.2.3 Report Rate

Number of milliseconds between two IN reports. This parameter will only be regarded if Report Mode = 2 (fixed rate)

Byte#	0	1	2	3	4	5	6
Content	GnS	Tgt	0x02	0x00	0x00	RptRate LSB	RptRate MSB

GnS: 0 = Set  
1 = Get

Tgt 0 = RAM  
1 = Flash

RptRate: Report Rate [ms]

### 3.2.4 Sample Rate

This is the actual sample rate the sensor is working on. If Report Mode = 0 (After Sampling) this is also the rate at which the device reports values to the host PC.

Byte#	0	1	2	3	4	5	6
Content	GnS	Tgt	0x02	0x01	0x00	SampRate LSB	SampRate MSB

GnS: 0 = Set  
1 = Get

Tgt 0 = RAM  
1 = Flash

SampRate: Sample Rate [ms]

### 3.2.5 User Device Name

Byte#	0	1	2	3	4	5-25
Content	GnS	Tgt	0x15	0x00	0x00	UsrDevName

GnS: 0 = Set  
1 = Get

Tgt 0 = RAM  
1 = Flash

UsrDevName: User defined name for the whole device  
Null-terminated string, max. 20+1 characters



## Oak MagR Datasheet

### 3.2.6 User Channel Name

Byte#	0	1	2	3	4	5-25
Content	GnS	Tgt	0x15	ChP1	0x00	UsrChName

GnS: 0 = Set  
1 = Get

Tgt 0 = RAM  
1 = Flash

ChP1 1 = Channel 0 (Frame Number)  
2 = Channel 1 (Angle)  
3 = Channel 2 (Magnitude)  
4 = Channel 3 (Status)

UsrChName: User defined name for the channel  
Null-terminated string, max. 20+1 characters

### 3.2.7 Restore Factory Defaults

Byte#	0	1	2	3	4	5-24
Content	0x00	0x01	0x14	0x00	0x00	Str

Str ASCII String "Set Factory Defaults"

### 3.2.8 Sensor Read Mode

Byte#	0	1	2	3	4	5
Content	GnS	Tgt	0x01	0x03	0x00	SNSREADMODE

GnS: 0 = Set  
1 = Get

Tgt 0 = RAM  
1 = Flash

SNSREADMODE: 0 = Read Angle, Slow Mode (Factory Default)  
1 = Read Angle, Fast Mode  
2 = Read Align Data, Slow Mode  
3 = Read Align Data, Fast Mode

Attention:

Switching the Read Mode will cause a power off/on cycle of the sensor IC !

### 3.2.9 Sensor OTP Register (User Settings)

Byte#	0	1	2	3	4	5	6
Content	GnS	Tgt	0x02	0x03	0x00	OTP LSB	OTP MSB

GnS: 0 = Set  
1 = Get

Tgt 0 = RAM  
1 = Flash

OTP: The sensor's OTP register (see sensor datasheet for details)  
Bit 15: CCW (0 = Clockwise rotation increases angle)  
Bit 14:3 Z11:0 (Zero Position, fractional 1/4096 of a full turn)  
Bit 2 PWM disable [PWM is only available at the sensor ic's leads]  
Bit 1 Magnetic Compensation Enable  
Bit 0 PWM half enable [PWM is only available at the sensor ic's leads]



### 3.2.10 Sensor OTP Register (Factory Settings)

Attention: This parameter should only be modified by very experienced users. Setting these bits incorrectly could lead to a malfunction of the sensor IC. This part of the OTP register is not documented in the sensor IC's datasheet, therefore it may change at any time without notice!

The factory default value of the parameter is 0x3C01.

Byte#	0	1	2	3	4	5	6
Content	GnS	Tgt	0x02	0x04	0x00	OTPF LSB	OTPF MSB

GnS: 0 = Set  
1 = Get

Tgt 0 = RAM  
1 = Flash

OTP: The sensor's factory settings part of the OTP register  
(This is not documented in the sensor's datasheet)  
Bit 15: ?  
Bit 14: Always reads "1"  
Bit 13:1 ?  
Bit 0: Always reads "1"

### 3.2.11 Read Serial Interface Unit (SIU)

Please refer to the AS5046 datasheet for details

Byte#	0	1	2	3	4
Content	0x01	0x02	0x01	0x28	0x00

Note: Although the sensor IC's I<sup>2</sup>C address of the SIU may change depending on the OTP register content, this command always uses the address 0x28

### 3.2.12 Hall Sensor Front End Register

Please refer to the AS5046 datasheet for details

Byte#	0	1	2	3	4	5
Content	GnS	0x02	0x01	HFE_Addr	0x00	HFE_Value

GnS: 0 = Set  
1 = Get

HFE\_Addr Address of the Hall Sensor Element  
H0 → 0x38, H7 → 0x3F

HFE\_Value Value to write into the register.  
Bit 7 TestEN always set to 0!  
Bit 6 SenseEN 1 = Hall Element Enable, 0 = disable  
Bit 5 -  
Bit 4 -  
Bit 3 COS\_EN 1 = add Element to COS signal bus  
Bit 2 SIN\_EN 1 = add Element to SIN signal bus  
Bit 1 Inv 1 = invert signal when adding, 0 = do not invert  
Bit 0 PD 1 = power down element, 0 = normal operation



## Oak MagR Datasheet

### 3.2.13 SIN/COS signal bus

Please refer to the AS5046 datasheet for details

Byte#	0	1	2	3	4	5	5	5
Content	GnS	0x02	0x03	0x20	0x00	COS_ MSB	SIN_ MSB	COS_ SIN_ LSB

GnS:           0 = Set  
               1 = Get

COS\_MSB      12-bit ADC output: COS signal bus, upper 8 bits

SIN\_MSB      12-bit ADC output: SIN signal bus, upper 8 bits

COS\_SIN\_LSB Bits7...4      COS signal bus, lower 4 bits  
              Bits 3...0      SIN signal bus, lower 4 bits

### 3.2.14 AGC

Byte#	0	1	2	3	4	5
Content	GnS	0x02	0x01	0x38	0x00	AGC

GnS:           0 = Set  
               1 = Get

AGC           Read → evaluate current AGC value  
               Write → Disable AGC



## 4. Technical Specifications

### 4.1 Electrical Specifications

Symbol	Parameter	Conditions	Min	Typ	Max	Unit
$I_q$	Operating current				40	mA
$I_{Stby}$	Standby current	No USB activity			500	$\mu$ A

### 4.2 Mechanical Dimensions

The PCB is designed to be mounted using two standard M2 screws. There are no components on the back side of the pcb.

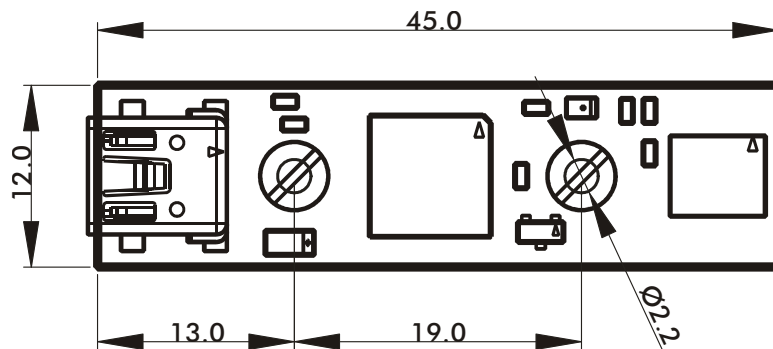

Figure 1: Mechanical dimensions of the Oak MagR sensor

### 4.3 RoHS Compliance

Unless otherwise stated, all Toradex products comply with the European Union's Directive 2002/95/EC: "Restrictions of Hazardous Substances".



**Disclaimer:**

Copyright © Toradex AG. All rights reserved. All data is for information purposes only and not guaranteed for legal purposes. Information has been carefully checked and is believed to be accurate; however, no responsibility is assumed for inaccuracies.

Brand and product names are trademarks or registered trademarks of their respective owners. Specifications are subject to change without notice.