

# EDT 7.0" TFT WVGA With Touch V1.0a Datasheet

Rev. 1.0

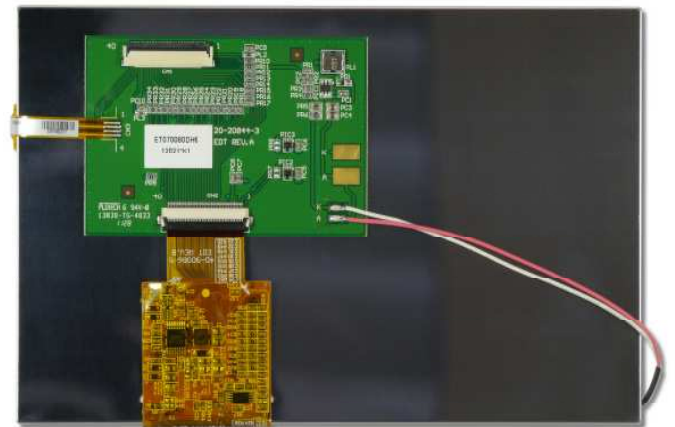

## Revision History

Date	Doc. Rev.	EDT 7.0" TFT WVGA with Touch Version	Changes
12-Mar-12	Rev. 1.0	V1.0a	Preliminary Release

EXAMINED BY: <i>Vincent Uh</i>	EMERGING DISPLAY TECHNOLOGIES CORPORATION	FILE NO . CAS-0006972
APPROVED BY: <i>David Chang</i>		ISSUE : APR.21, 2011
		TOTAL PAGE : 30
		VERSION : 4
CUSTOMER ACCEPTANCE SPECIFICATIONS		
<div style="border: 1px solid black; border-radius: 15px; padding: 20px; width: fit-content; margin: 0 auto;"> <p>MODEL NO. :</p> <p style="text-align: center;"><u>ET070080DH6</u></p> <p style="text-align: center;">(RoHS)</p> <p>FOR MESSRS :</p> <p style="text-align: center;">_____</p> </div>		
CUSTOMER'S APPROVAL		
DATE :		
_____		
BY :		
_____		

02101300-01-02



EMERGING DISPLAY TECHNOLOGIES CORPORATION		MODEL NO. ET070080DH6	VERSION 4	PAGE 0-1																																																																																																																																																																
RECORDS OF REVISION		DOC. FIRST ISSUE SEP.24, 2009																																																																																																																																																																		
DATE	REVISED PAGE NO.	SUMMARY																																																																																																																																																																		
SEP.30, 2009	3	4. ELECTRICAL CHARACTERISTICS VDD-VSS : 3.0(MIN.) → 3.2(MIN.) ADD NOTE(4)																																																																																																																																																																		
	12,13	10. INTERFACE SIGNALS NO.30-32 : ADD DE & SYNC MODE SETTING																																																																																																																																																																		
	14	11.1 POWER SUPPLY FOR LCM ADD MINIMUM 1KHz FREQUENCY MODIFY 11.2 THE BRIGHTNESS CONTROLLED BY BACKLIGHT CURRENT OF LEDCTRL.																																																																																																																																																																		
JAN.21, 2010	2	3.1 ELECTRICAL ABSOLUTE MAXIMUM RATINGS. <table border="1" style="width:100%; border-collapse: collapse;"> <thead> <tr> <th>PARAMETER</th> <th>SYMBOL</th> <th>MIN</th> <th>MAX</th> <th>UNIT</th> <th>REMARK</th> </tr> </thead> <tbody> <tr> <td>LED BACKLIGHT POWER DISSIPATION</td> <td>PD</td> <td>—</td> <td>2590</td> <td>mW</td> <td></td> </tr> <tr> <td>LED BACKLIGHT FORWARD CURRENT</td> <td>IF</td> <td>—</td> <td>800</td> <td>mA</td> <td></td> </tr> </tbody> </table> <table border="1" style="width:100%; border-collapse: collapse;"> <thead> <tr> <th>PARAMETER</th> <th>SYMBOL</th> <th>MIN</th> <th>MAX</th> <th>UNIT</th> <th>REMARK</th> </tr> </thead> <tbody> <tr> <td>LED BACKLIGHT POWER DISSIPATION</td> <td>PD</td> <td>—</td> <td>2592</td> <td>mW</td> <td></td> </tr> <tr> <td>LED BACKLIGHT FORWARD CURRENT</td> <td>IF</td> <td>—</td> <td>240</td> <td>mA</td> <td></td> </tr> </tbody> </table>			PARAMETER	SYMBOL	MIN	MAX	UNIT	REMARK	LED BACKLIGHT POWER DISSIPATION	PD	—	2590	mW		LED BACKLIGHT FORWARD CURRENT	IF	—	800	mA		PARAMETER	SYMBOL	MIN	MAX	UNIT	REMARK	LED BACKLIGHT POWER DISSIPATION	PD	—	2592	mW		LED BACKLIGHT FORWARD CURRENT	IF	—	240	mA																																																																																																																													
PARAMETER	SYMBOL	MIN	MAX	UNIT	REMARK																																																																																																																																																															
LED BACKLIGHT POWER DISSIPATION	PD	—	2590	mW																																																																																																																																																																
LED BACKLIGHT FORWARD CURRENT	IF	—	800	mA																																																																																																																																																																
PARAMETER	SYMBOL	MIN	MAX	UNIT	REMARK																																																																																																																																																															
LED BACKLIGHT POWER DISSIPATION	PD	—	2592	mW																																																																																																																																																																
LED BACKLIGHT FORWARD CURRENT	IF	—	240	mA																																																																																																																																																																
	3	4. ELECTRICAL CHARACTERISTICS <table border="1" style="width:100%; border-collapse: collapse;"> <thead> <tr> <th>PARAMETER</th> <th>SYMBOL</th> <th>CONDITION</th> <th>MIN</th> <th>TYP</th> <th>MAX</th> <th>UNIT</th> <th>REMARK</th> </tr> </thead> <tbody> <tr> <td>POWER SUPPLY CURRENT</td> <td>IDD</td> <td>VDD-VSS = 3.3V</td> <td>—</td> <td>(220)</td> <td>(270)</td> <td>mA</td> <td>NOTE (2)</td> </tr> <tr> <td>POWER SUPPLY CURRENT FOR LED DRIVER</td> <td>ICC</td> <td>VCC-VSS=3.3V LED B/L=ON</td> <td>—</td> <td>(600)</td> <td>(780)</td> <td>mA</td> <td></td> </tr> <tr> <td>LED LIFE TIME</td> <td>—</td> <td>—</td> <td>(30K)</td> <td>(40K)</td> <td>—</td> <td>HRS</td> <td></td> </tr> </tbody> </table> <table border="1" style="width:100%; border-collapse: collapse;"> <thead> <tr> <th>PARAMETER</th> <th>SYMBOL</th> <th>CONDITION</th> <th>MIN</th> <th>TYP</th> <th>MAX</th> <th>UNIT</th> <th>REMARK</th> </tr> </thead> <tbody> <tr> <td>POWER SUPPLY CURRENT</td> <td>IDD</td> <td>VDD-VSS = 3.3V</td> <td>—</td> <td>220</td> <td>270</td> <td>mA</td> <td>NOTE (2)</td> </tr> <tr> <td>POWER SUPPLY CURRENT FOR LED DRIVER</td> <td>ICC</td> <td>VCC-VSS=3.3V LED B/L=ON</td> <td>—</td> <td>600</td> <td>780</td> <td>mA</td> <td></td> </tr> <tr> <td>LED LIFE TIME</td> <td>—</td> <td>—</td> <td>30K</td> <td>40K</td> <td>—</td> <td>HRS</td> <td></td> </tr> </tbody> </table>			PARAMETER	SYMBOL	CONDITION	MIN	TYP	MAX	UNIT	REMARK	POWER SUPPLY CURRENT	IDD	VDD-VSS = 3.3V	—	(220)	(270)	mA	NOTE (2)	POWER SUPPLY CURRENT FOR LED DRIVER	ICC	VCC-VSS=3.3V LED B/L=ON	—	(600)	(780)	mA		LED LIFE TIME	—	—	(30K)	(40K)	—	HRS		PARAMETER	SYMBOL	CONDITION	MIN	TYP	MAX	UNIT	REMARK	POWER SUPPLY CURRENT	IDD	VDD-VSS = 3.3V	—	220	270	mA	NOTE (2)	POWER SUPPLY CURRENT FOR LED DRIVER	ICC	VCC-VSS=3.3V LED B/L=ON	—	600	780	mA		LED LIFE TIME	—	—	30K	40K	—	HRS																																																																																																	
PARAMETER	SYMBOL	CONDITION	MIN	TYP	MAX	UNIT	REMARK																																																																																																																																																													
POWER SUPPLY CURRENT	IDD	VDD-VSS = 3.3V	—	(220)	(270)	mA	NOTE (2)																																																																																																																																																													
POWER SUPPLY CURRENT FOR LED DRIVER	ICC	VCC-VSS=3.3V LED B/L=ON	—	(600)	(780)	mA																																																																																																																																																														
LED LIFE TIME	—	—	(30K)	(40K)	—	HRS																																																																																																																																																														
PARAMETER	SYMBOL	CONDITION	MIN	TYP	MAX	UNIT	REMARK																																																																																																																																																													
POWER SUPPLY CURRENT	IDD	VDD-VSS = 3.3V	—	220	270	mA	NOTE (2)																																																																																																																																																													
POWER SUPPLY CURRENT FOR LED DRIVER	ICC	VCC-VSS=3.3V LED B/L=ON	—	600	780	mA																																																																																																																																																														
LED LIFE TIME	—	—	30K	40K	—	HRS																																																																																																																																																														
	7	6.1 OPTICAL CHARACTERISTICS <table border="1" style="width:100%; border-collapse: collapse;"> <thead> <tr> <th>ITEM</th> <th>SYMBOL</th> <th>CONDITION</th> <th>MIN</th> <th>TYP</th> <th>MAX</th> <th>UNIT</th> <th>REMARK</th> </tr> </thead> <tbody> <tr> <td rowspan="3">VIEWING ANGLE</td> <td><math>\theta_v</math></td> <td rowspan="3"><math>CR \geq 10</math></td> <td><math>\theta_v=0^\circ</math></td> <td>(60)</td> <td>(65)</td> <td>—</td> <td rowspan="3">deg NOTE (2) NOTE (3)</td> </tr> <tr> <td><math>\theta_v</math></td> <td>(60)</td> <td>(65)</td> <td>—</td> </tr> <tr> <td><math>\theta_v</math></td> <td>(65)</td> <td>(70)</td> <td>—</td> </tr> <tr> <td>CONTRAST RATIO</td> <td>CR</td> <td><math>\theta_v=0^\circ, \theta_y=0^\circ</math></td> <td>(300)</td> <td>—</td> <td>—</td> <td>—</td> <td>NOTE (3)</td> </tr> <tr> <td rowspan="6">COLOR OF THE COORDINATE</td> <td rowspan="3">WHITE</td> <td rowspan="6"><math>\theta_v=0^\circ, \theta_y=0^\circ</math> IF = 160mA (NTSC: 45%)</td> <td>Wx</td> <td>(0.26)</td> <td>(0.31)</td> <td>(0.36)</td> <td rowspan="6">—</td> </tr> <tr> <td>Wy</td> <td>(0.29)</td> <td>(0.34)</td> <td>(0.39)</td> </tr> <tr> <td>Rx</td> <td>(0.56)</td> <td>(0.61)</td> <td>(0.66)</td> </tr> <tr> <td rowspan="3">GREEN</td> <td>Ry</td> <td>(0.30)</td> <td>(0.35)</td> <td>(0.40)</td> <td rowspan="3">—</td> </tr> <tr> <td>Gx</td> <td>(0.26)</td> <td>(0.31)</td> <td>(0.36)</td> </tr> <tr> <td>Gy</td> <td>(0.49)</td> <td>(0.54)</td> <td>(0.59)</td> </tr> <tr> <td rowspan="2">BLUE</td> <td>Bx</td> <td>(0.09)</td> <td>(0.14)</td> <td>(0.19)</td> <td rowspan="2">—</td> </tr> <tr> <td>By</td> <td>(0.11)</td> <td>(0.16)</td> <td>(0.21)</td> </tr> <tr> <td>THE BRIGHTNESS OF MODULE</td> <td>B</td> <td><math>\theta_v=0^\circ, \theta_y=0^\circ</math> IF = 160mA</td> <td>(250)</td> <td>—</td> <td>—</td> <td>cd/m<sup>2</sup></td> <td>NOTE (6)</td> </tr> </tbody> </table> <table border="1" style="width:100%; border-collapse: collapse;"> <thead> <tr> <th>ITEM</th> <th>SYMBOL</th> <th>CONDITION</th> <th>MIN</th> <th>TYP</th> <th>MAX</th> <th>UNIT</th> <th>REMARK</th> </tr> </thead> <tbody> <tr> <td rowspan="3">VIEWING ANGLE</td> <td><math>\theta_v</math></td> <td rowspan="3"><math>CR \geq 10</math></td> <td><math>\theta_v=0^\circ</math></td> <td>60</td> <td>65</td> <td>—</td> <td rowspan="3">deg NOTE (2) NOTE (3)</td> </tr> <tr> <td><math>\theta_v</math></td> <td>60</td> <td>65</td> <td>—</td> </tr> <tr> <td><math>\theta_v</math></td> <td>65</td> <td>70</td> <td>—</td> </tr> <tr> <td>CONTRAST RATIO</td> <td>CR</td> <td><math>\theta_v=0^\circ, \theta_y=0^\circ</math></td> <td>300</td> <td>350</td> <td>—</td> <td>—</td> <td>NOTE (3)</td> </tr> <tr> <td rowspan="6">COLOR OF THE COORDINATE</td> <td rowspan="3">WHITE</td> <td rowspan="6"><math>\theta_v=0^\circ, \theta_y=0^\circ</math> (NTSC: 45%)</td> <td>Wx</td> <td>0.26</td> <td>0.31</td> <td>0.36</td> <td rowspan="6">—</td> </tr> <tr> <td>Wy</td> <td>0.29</td> <td>0.34</td> <td>0.39</td> </tr> <tr> <td>Rx</td> <td>0.51</td> <td>0.56</td> <td>0.61</td> </tr> <tr> <td rowspan="3">GREEN</td> <td>Ry</td> <td>0.29</td> <td>0.34</td> <td>0.39</td> <td rowspan="3">—</td> </tr> <tr> <td>Gx</td> <td>0.28</td> <td>0.33</td> <td>0.38</td> </tr> <tr> <td>Gy</td> <td>0.33</td> <td>0.38</td> <td>0.43</td> </tr> <tr> <td rowspan="2">BLUE</td> <td>Bx</td> <td>0.10</td> <td>0.15</td> <td>0.20</td> <td rowspan="2">—</td> </tr> <tr> <td>By</td> <td>0.07</td> <td>0.12</td> <td>0.17</td> </tr> <tr> <td>THE BRIGHTNESS OF MODULE</td> <td>B</td> <td><math>\theta_v=0^\circ, \theta_y=0^\circ</math> IF = 160mA</td> <td>250</td> <td>—</td> <td>—</td> <td>cd/m<sup>2</sup></td> <td>NOTE (6)</td> </tr> </tbody> </table>			ITEM	SYMBOL	CONDITION	MIN	TYP	MAX	UNIT	REMARK	VIEWING ANGLE	$\theta_v$	$CR \geq 10$	$\theta_v=0^\circ$	(60)	(65)	—	deg NOTE (2) NOTE (3)	$\theta_v$	(60)	(65)	—	$\theta_v$	(65)	(70)	—	CONTRAST RATIO	CR	$\theta_v=0^\circ, \theta_y=0^\circ$	(300)	—	—	—	NOTE (3)	COLOR OF THE COORDINATE	WHITE	$\theta_v=0^\circ, \theta_y=0^\circ$ IF = 160mA (NTSC: 45%)	Wx	(0.26)	(0.31)	(0.36)	—	Wy	(0.29)	(0.34)	(0.39)	Rx	(0.56)	(0.61)	(0.66)	GREEN	Ry	(0.30)	(0.35)	(0.40)	—	Gx	(0.26)	(0.31)	(0.36)	Gy	(0.49)	(0.54)	(0.59)	BLUE	Bx	(0.09)	(0.14)	(0.19)	—	By	(0.11)	(0.16)	(0.21)	THE BRIGHTNESS OF MODULE	B	$\theta_v=0^\circ, \theta_y=0^\circ$ IF = 160mA	(250)	—	—	cd/m <sup>2</sup>	NOTE (6)	ITEM	SYMBOL	CONDITION	MIN	TYP	MAX	UNIT	REMARK	VIEWING ANGLE	$\theta_v$	$CR \geq 10$	$\theta_v=0^\circ$	60	65	—	deg NOTE (2) NOTE (3)	$\theta_v$	60	65	—	$\theta_v$	65	70	—	CONTRAST RATIO	CR	$\theta_v=0^\circ, \theta_y=0^\circ$	300	350	—	—	NOTE (3)	COLOR OF THE COORDINATE	WHITE	$\theta_v=0^\circ, \theta_y=0^\circ$ (NTSC: 45%)	Wx	0.26	0.31	0.36	—	Wy	0.29	0.34	0.39	Rx	0.51	0.56	0.61	GREEN	Ry	0.29	0.34	0.39	—	Gx	0.28	0.33	0.38	Gy	0.33	0.38	0.43	BLUE	Bx	0.10	0.15	0.20	—	By	0.07	0.12	0.17	THE BRIGHTNESS OF MODULE	B	$\theta_v=0^\circ, \theta_y=0^\circ$ IF = 160mA	250	—	—	cd/m <sup>2</sup>	NOTE (6)
ITEM	SYMBOL	CONDITION	MIN	TYP	MAX	UNIT	REMARK																																																																																																																																																													
VIEWING ANGLE	$\theta_v$	$CR \geq 10$	$\theta_v=0^\circ$	(60)	(65)	—	deg NOTE (2) NOTE (3)																																																																																																																																																													
	$\theta_v$		(60)	(65)	—																																																																																																																																																															
	$\theta_v$		(65)	(70)	—																																																																																																																																																															
CONTRAST RATIO	CR	$\theta_v=0^\circ, \theta_y=0^\circ$	(300)	—	—	—	NOTE (3)																																																																																																																																																													
COLOR OF THE COORDINATE	WHITE	$\theta_v=0^\circ, \theta_y=0^\circ$ IF = 160mA (NTSC: 45%)	Wx	(0.26)	(0.31)	(0.36)	—																																																																																																																																																													
			Wy	(0.29)	(0.34)	(0.39)																																																																																																																																																														
			Rx	(0.56)	(0.61)	(0.66)																																																																																																																																																														
	GREEN		Ry	(0.30)	(0.35)	(0.40)		—																																																																																																																																																												
			Gx	(0.26)	(0.31)	(0.36)																																																																																																																																																														
			Gy	(0.49)	(0.54)	(0.59)																																																																																																																																																														
BLUE	Bx	(0.09)	(0.14)	(0.19)	—																																																																																																																																																															
	By	(0.11)	(0.16)	(0.21)																																																																																																																																																																
THE BRIGHTNESS OF MODULE	B	$\theta_v=0^\circ, \theta_y=0^\circ$ IF = 160mA	(250)	—	—	cd/m <sup>2</sup>	NOTE (6)																																																																																																																																																													
ITEM	SYMBOL	CONDITION	MIN	TYP	MAX	UNIT	REMARK																																																																																																																																																													
VIEWING ANGLE	$\theta_v$	$CR \geq 10$	$\theta_v=0^\circ$	60	65	—	deg NOTE (2) NOTE (3)																																																																																																																																																													
	$\theta_v$		60	65	—																																																																																																																																																															
	$\theta_v$		65	70	—																																																																																																																																																															
CONTRAST RATIO	CR	$\theta_v=0^\circ, \theta_y=0^\circ$	300	350	—	—	NOTE (3)																																																																																																																																																													
COLOR OF THE COORDINATE	WHITE	$\theta_v=0^\circ, \theta_y=0^\circ$ (NTSC: 45%)	Wx	0.26	0.31	0.36	—																																																																																																																																																													
			Wy	0.29	0.34	0.39																																																																																																																																																														
			Rx	0.51	0.56	0.61																																																																																																																																																														
	GREEN		Ry	0.29	0.34	0.39		—																																																																																																																																																												
			Gx	0.28	0.33	0.38																																																																																																																																																														
			Gy	0.33	0.38	0.43																																																																																																																																																														
BLUE	Bx	0.10	0.15	0.20	—																																																																																																																																																															
	By	0.07	0.12	0.17																																																																																																																																																																
THE BRIGHTNESS OF MODULE	B	$\theta_v=0^\circ, \theta_y=0^\circ$ IF = 160mA	250	—	—	cd/m <sup>2</sup>	NOTE (6)																																																																																																																																																													
APR.21, 2011	2	3.1 ELECTRICAL ABSOLUTE MAXIMUM RATINGS VDD-VSS: (MAX.) +7→(MAX.) 6.5																																																																																																																																																																		
	8	NOTE (2) : $\theta_y- \rightarrow \theta_y+$ NOTE (4) : TR AND TF → T <sub>R</sub> AND T <sub>F</sub>																																																																																																																																																																		

02101300-01-02



EMERGING DISPLAY  
TECHNOLOGIES CORPORATION

MODEL NO. ET070080DH6
--------------------------

VERSION 4
--------------

PAGE 0-2
-------------

TABLE OF CONTENTS

NO.	ITEM	PAGE
1.	GENERAL SPECIFICATIONS -----	1
2.	MECHANICAL SPECIFICATIONS -----	1
3.	ABSOLUTE MAXIMUM RATINGS -----	2
4.	ELECTRICAL CHARACTERISTICS -----	3
5.	TIMING CHARACTERISTICS -----	4 ~ 6
6.	OPTICAL CHARACTERISTICS -----	7, 8
7.	OUTLINE DIMENSIONS -----	9
8.	BLOCK DIAGRAM -----	10
9.	DETAIL DRAWING OF DOT MATRIX -----	11
10.	INTERFACE SIGNALS -----	12, 13
11.	POWER SUPPLY -----	14
12.	TOUCH PANEL SPECIFICATION -----	15 ~ 20
13.	INSPECTION CRITERION -----	21 ~ 30

02101300-01-02



EMERGING DISPLAY TECHNOLOGIES CORPORATION	MODEL NO. ET070080DH6	VERSION 4	PAGE 1
<p>1. GENERAL SPECIFICATIONS</p> <p>1.1 APPLICATION NOTES FOR CONTROLLER/DRIVER PLEASE REFER TO :</p> <p style="text-align: center;">HIMAX HX8262-A HIMAX HX8678-A</p> <p>1.2 MATERIAL SAFETY DESCRIPTION ASSEMBLIES SHALL COMPLY WITH EUROPEAN ROHS REQUIREMENTS, INCLUDING PROHIBITED MATERIALS/COMPONENTS CONTAINING LEAD, MERCURY, CADMIUM, HEXAVALENT CHROMIUM, POLYBROMINATED BIPHENYLS (PBB) AND POLYBROMINATED DIPHENYL ETHERS (PBDE)</p> <p>2. MECHANICAL SPECIFICATIONS</p> <p>(1) DISPLAY SIZE ----- 7 inch</p> <p>(2) NUMBER OF DOTS ----- 800W * (RGB) * 480H DOTS</p> <p>(3) MODULE SIZE ----- 166W * 105.44H * 10.95D(MAX.) mm (WITHOUT FPC &amp; LED BL'S CABLE)</p> <p>(4) EFFECTIVE AREA ----- 155.6W * 94.6H mm (T/P)</p> <p>(5) ACTIVE AREA ----- 152.4W * 91.44H mm (LCD) 154W * 93.04H mm (T/P)</p> <p>(6) DOT SIZE ----- 0.0635W * 0.1905H mm</p> <p>(7) PIXEL SIZE ----- 0.1905W * 0.1905H mm</p> <p>(8) LCD TYPE ----- TFT , TRANSMISSIVE, ANTE-GLARE</p> <p>(9) COLOR ----- 262K</p> <p>(10) VIEWING DIRECTION ----- 6 O'CLOCK</p> <p>(11) BACK LIGHT ----- LED , COLOR : WHITE</p> <p>(12) INTERFACE MODE ----- RGB 18BIT PARALLEL (DE/SYNC MODE)</p>			

EMERGING DISPLAY TECHNOLOGIES CORPORATION	MODEL NO.	VERSION	PAGE
	ET070080DH6	4	2

3. ABSOLUTE MAXIMUM RATINGS

3.1 ELECTRICAL ABSOLUTE MAXIMUM RATINGS.

PARAMETER	SYMBOL	MIN.	MAX.	UNIT	REMARK
POWER SUPPLY VOLTAGE	VDD-VSS	-0.5	6.5	V	
INPUT VOLTAGE	VIN-VSS	-0.3	VDD+0.3	V	
STATIC ELECTRICITY	—	—	—	V	NOTE(1)
LED BACKLIGHT POWER DISSIPATION	PD	—	2592	mW	
LED BACKLIGHT FORWARD CURRENT	IF	—	240	mA	

3.2 ENVIRONMENTAL ABSOLUTE MAXIMUM RATINGS.

I T E M	OPERATING		STORAGE		REMARK
	MIN.	MAX.	MIN.	MAX.	
AMBIENT TEMPERATURE	-20°C	70°C	-30°C	80°C	NOTE ( 1 ) , ( 2 )
HUMIDITY	NOTE ( 3 )		NOTE ( 3 )		WITHOUT CONDENSATION
VIBRATION	—	2.45 m/s <sup>2</sup> ( 0.25 G )	—	11.76 m/s <sup>2</sup> ( 1.2 G )	5~20Hz , 1HR 20~500Hz(20Hz) , 1HR 20~500Hz(500Hz) , 1HR X,Y,Z,TOTAL 3HRS
SHOCK	—	29.4 m/s <sup>2</sup> ( 3 G )	—	490 m/s <sup>2</sup> ( 50 G )	10 m SECONDS XYZ DIRECTIONS 1 TIME EACH
CORROSIVE GAS	NOT ACCEPTABLE		NOT ACCEPTABLE		

NOTE ( 1 ) : Ta AT -30°C : 48HRS MAX.  
80°C : 168HRS MAX.

NOTE ( 2 ) : BACKGROUND COLOR CHANGES SLIGHTLY DEPENDING ON AMBIENT TEMPERATURE  
THIS PHENOMENON IS REVERSIBLE.

NOTE ( 3 ) : Ta ≤ 60°C : 90%RH MAX (96HRS MAX).  
Ta > 60°C : ABSOLUTE HUMIDITY MUST BE LOWER THAN THE HUMIDITY  
OF 90%RH AT 60°C(96HRS MAX).

02101300-01-02

**Disclaimer:**

EMERGING DISPLAY TECHNOLOGIES CORPORATION	MODEL NO.	VERSION	PAGE
	ET070080DH6	4	3

4. ELECTRICAL CHARACTERISTICS

Ta = 25 °C

PARAMETER	SYMBOL	CONDITION	MIN.	TYP.	MAX.	UNIT	REMARK
POWER SUPPLY VOLTAGE	VDD-VSS	—	3.2	3.3	3.6	V	
POWER SUPPLY VOLTAGE FOR LED DRIVER	VCC-VSS	—	2.5	3.3	3.6	V	
LOW LEVEL INPUT VOLTAGE	VIL	—	0	—	0.3*VDD	V	NOTE (1)
HIGH LEVEL INPUT VOLTAGE	VIH	—	0.7*VDD	—	VDD	V	NOTE (1)
POWER SUPPLY CURRENT	IDD	VDD-VSS = 3.3V	—	220	270	mA	NOTE (2)
POWER SUPPLY CURRENT FOR LED DRIVER	ICC	VCC-VSS=3.3V LED B/L=ON	—	600	780	mA	
DIMMING CONTROL FOR LED BACKLIGHT	LEDCTRL-VSS	—	0	—	3	V	NOTE (3)
	PWM	1KHz	—	3.3	—	V	
LED LIFE TIME	—	—	30K	40K	—	HRS	

NOTE (1) : APPLIED TO TERMINALS B5~B0, G5~G0, R5~R0, DCLK, HSYNC, VSYNC, ENB, ROTATE.

NOTE (2) : THE DISPLAY PATTERN IS ALL "WHITE".

NOTE (3) : INTERNAL CIRCUIT DIAGRAM OF BACKLIGHT

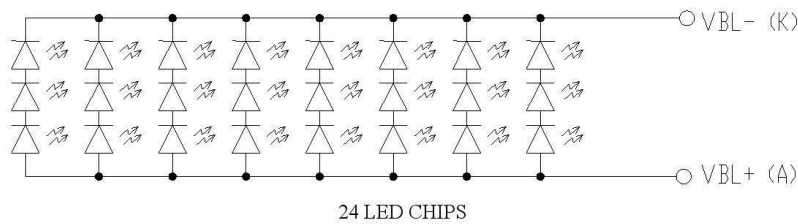

NOTE (4) : AMBIENT TEMP. VS. ALLOWABLE FORWARD CURRENT. (PER. LED)

Ambient Temperature vs.  
Allowable Forward Current

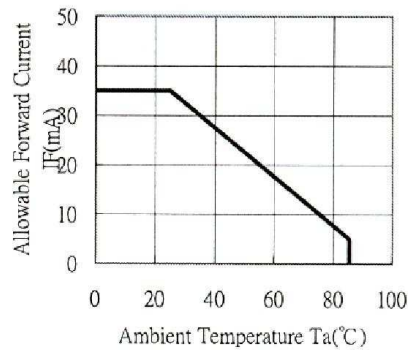

02101300-01-02

5. TIMING CHARACTERISTICS  
5.1 AC ELECTRICAL CHARACTERISTICS

PARAMETER	SYMBOL	MIN.	TYP.	MAX.	UNIT
HSYNC SETUP TIME	T <sub>hst</sub>	6	—	—	ns
HSYNC HOLD TIME	T <sub>hhd</sub>	6	—	—	ns
VSYNC SETUP TIME	T <sub>vst</sub>	6	—	—	ns
VSYNC HOLD TIME	T <sub>vhd</sub>	6	—	—	ns
DATA SETUP TIME	T <sub>dsu</sub>	6	—	—	ns
DATA HOLD TIME	T <sub>dhd</sub>	6	—	—	ns
ENB SETUP TIME	T <sub>esu</sub>	6	—	—	ns
SOURCE OUTPUT SETTLING TIME	T <sub>ST</sub>	—	—	15	μs
SOURCE OUTPUT LOADING R	R <sub>SL</sub>	—	2	—	K ohm
SOURCE OUTPUT LOADING C	C <sub>SL</sub>	—	60	—	pF

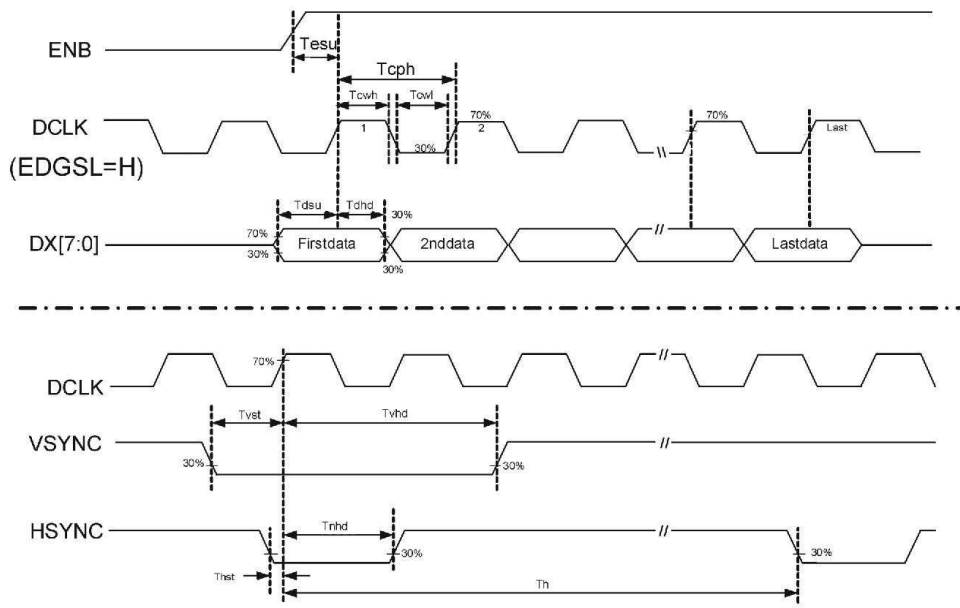

02101300-01-02

5.2 SYNC MODE SIGNAL CHARACTERISTICS

PARAMETER	SYMBOL	SPEC			UNIT
		MIN.	TYP.	MAX.	
DCLK FREQUENCY	$F_{CPH}$	—	33.26	—	MHz
DCLK PERIOD	$T_{CPH}$	—	30.06	—	ns
DCLK PULSE DUTY	$T_{CWH}$	40	50	60	%
HSYNC PERIOD	$T_H$	930	1056	1057	$T_{CPH}$
HSYNC PULSE WIDTH	$T_{WH}$	1	128	—	$T_{CPH}$
HSYNC -FIRST HORIZONTAL DATA TIME	$T_{HS}$	—	216	—	$T_{CPH}$
HSYNC ACTIVE TIME	$T_{HA}$	—	800	—	$T_{CPH}$
VSYNC PERIOD	$T_V$	—	525	—	$T_H$
VSYNC PULSE WIDTH	$T_{WV}$	1	2	—	$T_H$
VSYNC -DE TIME	$T_{VS}$	—	35	—	$T_H$
VSYNC ACTIVE TIME	$T_{VA}$	—	480	—	$T_H$

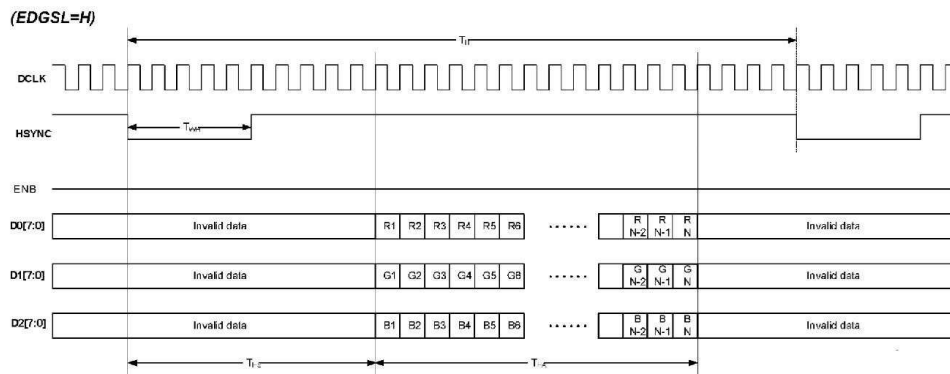

SYNC Mode Horizontal Data Format

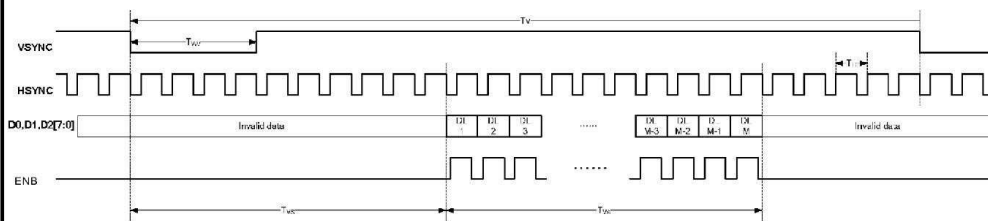

SYNC Mode Vertical Data Format

02101300-01-02

5.3 DE MODE SIGNAL CHARACTERISTICS

PARAMETER	SYMBOL	MIN.	TYP.	MAX.	UNIT
DCLK FREQUENCY	$F_{CPH}$	—	33.26	—	MHZ
DCLK PERIOD	$T_{CPH}$	—	30.06	—	ns
DCLK PULSE DUTY	$T_{CWH}$	40	50	60	%
ENB PERIOD	$T_{DEH} + T_{DEL}$	1000	1056	1200	$T_{CPH}$
ENB PULSE WIDTH	$T_{DEB}$	—	800	—	$T_{CPH}$
ENB FRAME BLANKING	$T_{DEB}$	10	45	110	$T_{DEH} + T_{DEL}$
ENB FRAME WIDTH	$T_{DE}$	—	480	—	$T_{DEH} + T_{DEL}$
OEV PULSE WIDTH	$T_{OEV}$	—	150	—	$T_{CPH}$
CKV PULSE WIDTH	$T_{CKV}$	—	133	—	$T_{CPH}$
ENB(INTERNAL)-STV TIME	$T_1$	—	4	—	$T_{CPH}$
ENB(INTERNAL)-CKV TIME	$T_2$	—	40	—	$T_{CPH}$
ENB(INTERNAL)-OEV TIME	$T_3$	—	23	—	$T_{CPH}$
ENB(INTERNAL)-POL TIME	$T_4$	—	157	—	$T_{CPH}$
STV PULSE WIDTH	—	—	1	—	$T_H$

NOTE : (1)  $T_{HS} + T_{HA} < T_H$

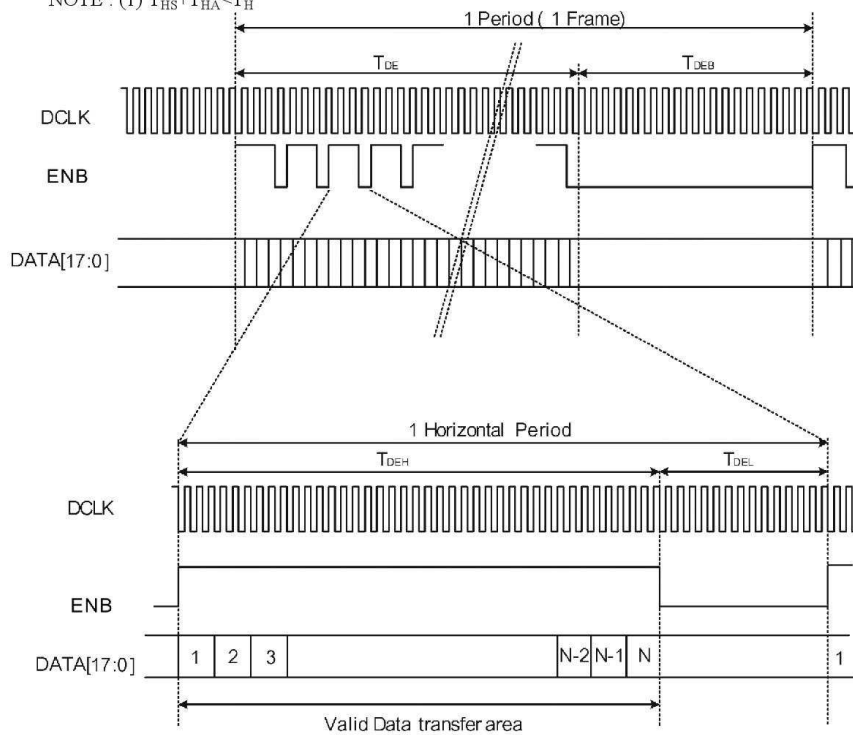

02101300-01-02

EMERGING DISPLAY TECHNOLOGIES CORPORATION	MODEL NO.	VERSION	PAGE
	ET070080DH6	4	7

6. OPTICAL CHARACTERISTICS (NOTE 1)  
6.1 OPTICAL CHARACTERISTICS

Ta = 25 ± 2 °C

I T E M		SYMBOL	CONDITION	MIN.	TYP.	MAX.	UNIT	REMARK
VIEWING ANGLE		$\theta_{y+}$	CR ≥ 10	60	65	—	deg.	NOTE (2) NOTE (3)
		$\theta_{y-}$		60	65	—		
		$\theta_{x+}$		65	70	—		
		$\theta_{x-}$		65	70	—		
CONTRAST RATIO		CR	$\theta_x=0^\circ, \theta_y=0^\circ$	300	350	—	—	NOTE (3)
RESPONSE TIME		$T_R$ (rise)	$\theta_x=0^\circ, \theta_y=0^\circ$	—	5	10	msec	NOTE (4)
		$T_F$ (fall)		—	15	20		
COLOR OF CIE COORDINATE	WHITE	$W_x$	$\theta_x=0^\circ, \theta_y=0^\circ$ IF = 160 mA (NTSC : 45 %)	0.26	0.31	0.36	—	NOTE (5)
		$W_y$		0.29	0.34	0.39		
	RED	$R_x$		0.51	0.56	0.61	—	
		$R_y$		0.29	0.34	0.39		
	GREEN	$G_x$		0.28	0.33	0.38	—	
		$G_y$		0.53	0.58	0.63		
	BLUE	$B_x$		0.10	0.15	0.20	—	
		$B_y$		0.07	0.12	0.17		
THE BRIGHTNESS OF MODULE		B	$\theta_x=0^\circ, \theta_y=0^\circ$ IF = 160mA	250	—	—	cd/m <sup>2</sup>	NOTE (6)
THE UNIFORMITY OF MODULE		—		75	80	—	%	

NOTE (1) : TEST EQUIPMENT SETUP :

AFTER STABILIZING AND LEAVING THE PANEL ALONE AT A GIVEN TEMPERATURE FOR 30 MINUTES, THE MEASUREMENT SHOULD BE EXECUTED. MEASUREMENT SHOULD BE EXECUTED IN A STABLE, WINDLESS, AND DARK ROOM. OPTICAL SPECIFICATIONS ARE MEASURED BY TOPCON BM-7 (FAST) WITH A VIEWING ANGLE OF 1° AT A DISTANCE OF 50cm AND NORMAL DIRECTION.

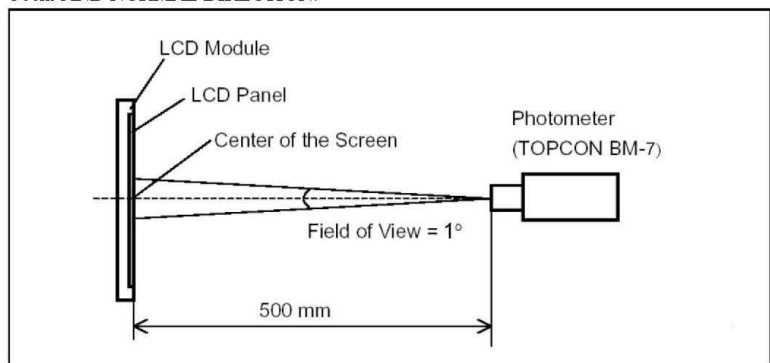

02101300-01-02

EMERGING DISPLAY  
TECHNOLOGIES CORPORATION

MODEL NO.  
ET070080DH6

VERSION  
4

PAGE  
8

NOTE (2) : DEFINITION OF VIEWING ANGLE :

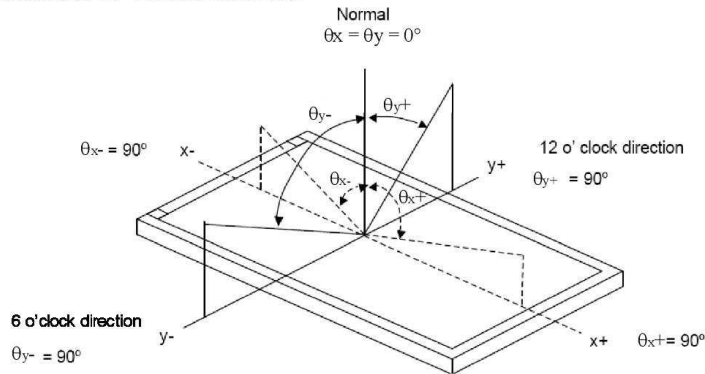

NOTE (3) : DEFINITION OF CONTRAST RATIO :

$$\text{CONTRAST RATIO(CR)} = \frac{\text{BRIGHTNESS MEASURED WHEN LCD IS AT "WHITE STATE"}}{\text{BRIGHTNESS MEASURED WHEN LCD IS AT "BLACK STATE"}}$$

NOTE (4) : DEFINITION OF RESPONSE TIME :  $T_R$  AND  $T_F$

THE FIGURE BELOW IS THE OUTPUT SIGNAL OF THE PHOTO DETECTOR.

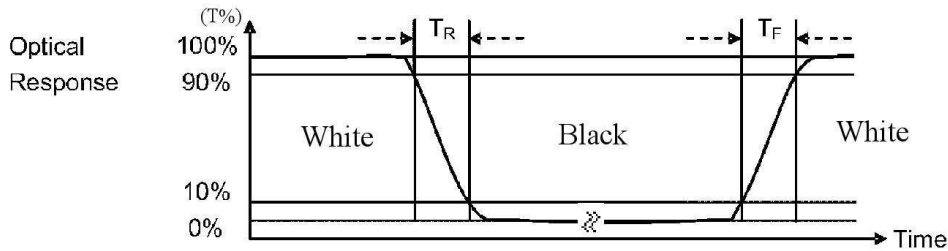

NOTE (5) : THE 100% TRANSMISSION IS DEFINED AS THE TRANSMISSION OF LCD PANEL WHEN ALL THE INPUT TERMINALS OF MODULE ARE ELECTRICALLY OPENED.

NOTE (6) : BRIGHTNESS MEASURED WHEN LCD IS AT "WHITE STATE"

### 6.2 THE TEST METHOD OF BRIGHTNESS AND UNIFORMITY

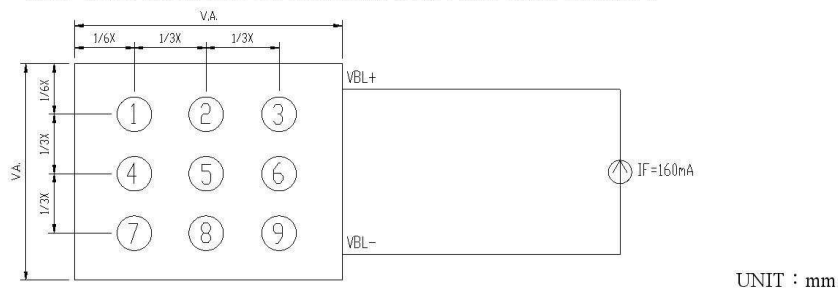

### 6.3 THE CALCULATING METHOD OF UNIFORMITY

$$\text{UNIFORMITY} = \left[ 1 - \frac{\text{MAXIMUM BRIGHTNESS} - \text{MINIMUM BRIGHTNESS}}{\text{AVERAGE BRIGHTNESS}} \right] \times 100\%$$

02101300-01-02

EMERGING DISPLAY  
TECHNOLOGIES CORPORATION

MODEL NO.  
ET070080DH6

VERSION  
4

PAGE  
9

7. OUTLINE DIMENSIONS

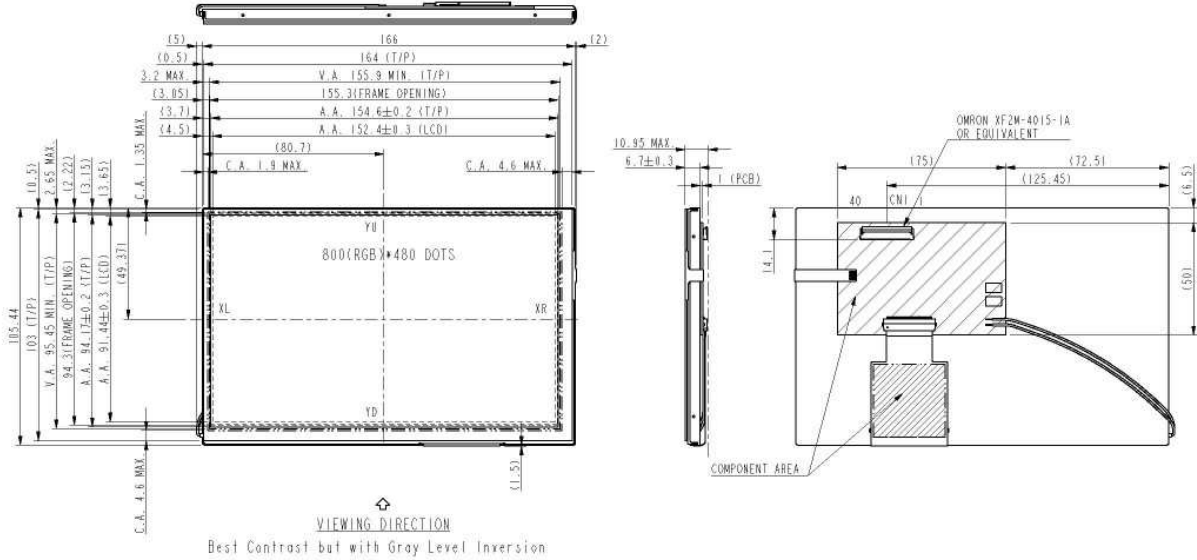

UNIT : mm  
SCALE : NTS  
NOT SPECIFIED TOLERANCE IS ± 0.5

02101300-01-02

8. BLOCK DIAGRAM

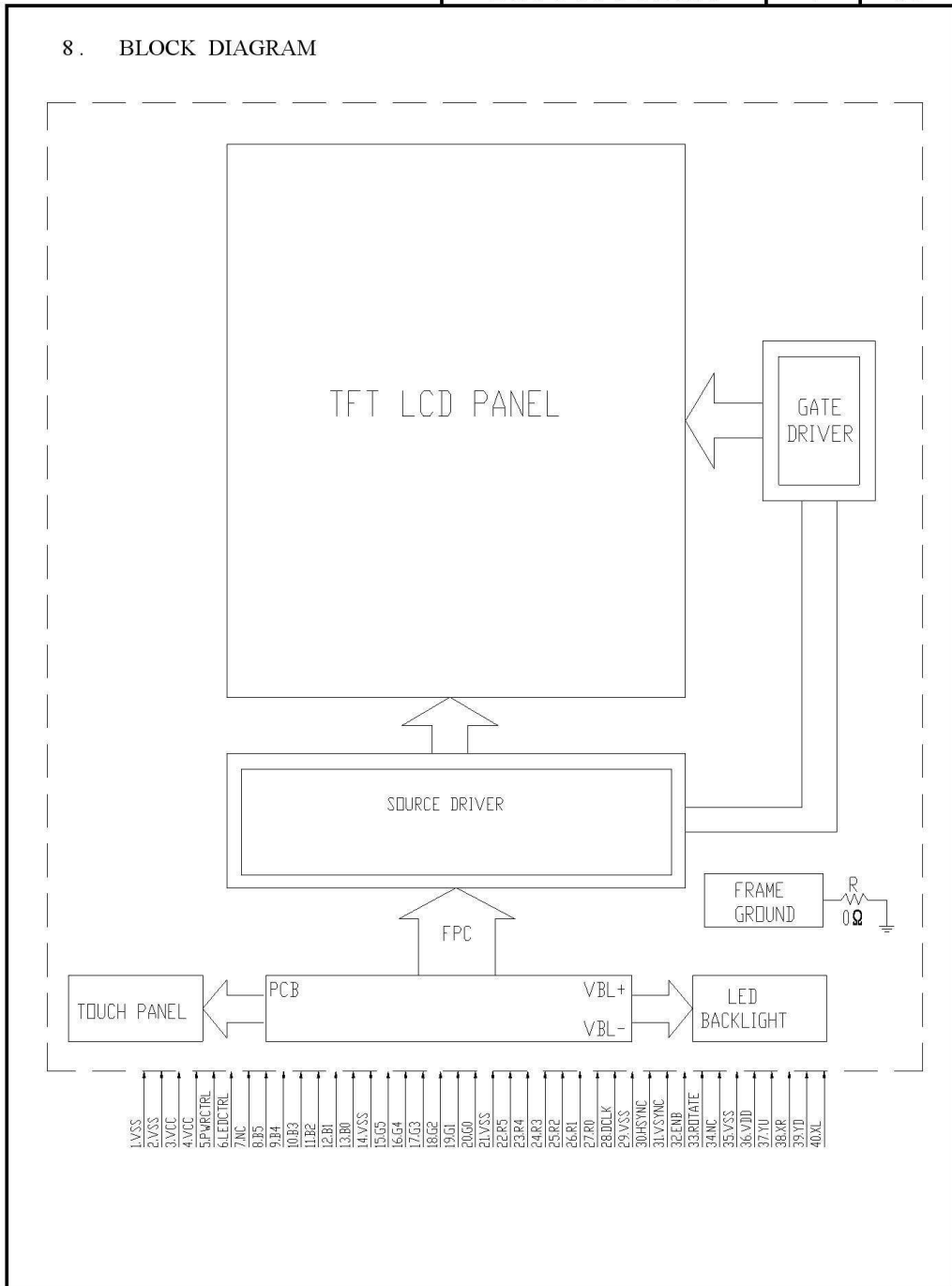

02101300-01-02

9. DETAIL DRAWING OF DOT MATRIX

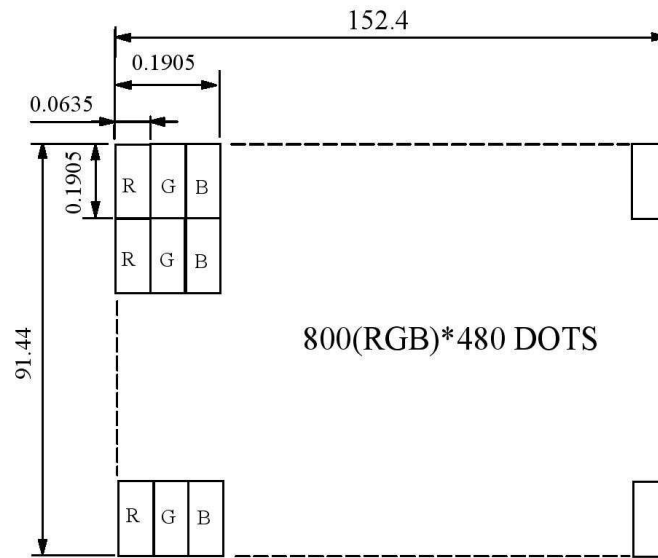

UNIT : mm  
SCALE : NTS  
NOT SPECIFIED TOLERANCE IS  $\pm 0.1$   
DOTS MATRIX TOLERANCE IS  $\pm 0.01$

02101300-01-02

**EMERGING DISPLAY**  
 TECHNOLOGIES CORPORATION

MODEL NO .

E T 0 7 0 0 8 0 D H 6

VERSION

4

PAGE

12

## 10. INTERFACE SIGNALS

PIN NO	SYMBOL	I/O	FUNCTION									
1	VSS	P	GROUND (VSS IS CONNECTED TO METAL HOUSING WITH CONDUCTIVE TAPE)									
2	VSS	P										
3	VCC	P	POWER SUPPLY FOR LED DRIVER CIRCUIT									
4	VCC	P	POWER SUPPLY FOR LED DRIVER CIRCUIT									
5	PWCTRL	I	<table border="1"> <thead> <tr> <th>LOGIC LEVEL</th> <th>PWCTRL</th> <th>REMARK</th> </tr> </thead> <tbody> <tr> <td>H=3.3V</td> <td>H</td> <td>POWER ON</td> </tr> <tr> <td>L=0V</td> <td>L</td> <td>SHUTDOWN</td> </tr> </tbody> </table>	LOGIC LEVEL	PWCTRL	REMARK	H=3.3V	H	POWER ON	L=0V	L	SHUTDOWN
			LOGIC LEVEL	PWCTRL	REMARK							
H=3.3V	H	POWER ON										
L=0V	L	SHUTDOWN										
6	LEDCTRL	I	BRIGHTNESS CONTROL FOR LED BACKLIGHT : POWER SUPPLY 0~3V OR PWM SIGNAL									
7	NC	—	NON CONNECTION									
8	B5	I	BLUE DATA BIT 5									
9	B4	I	BLUE DATA BIT 4									
10	B3	I	BLUE DATA BIT 3									
11	B2	I	BLUE DATA BIT 2									
12	B1	I	BLUE DATA BIT 1									
13	B0	I	BLUE DATA BIT 0									
14	VSS	P	GROUND (VSS IS CONNECTED TO METAL HOUSING WITH CONDUCTIVE TAPE)									
15	G5	I	GREEN DATA BIT 5									
16	G4	I	GREEN DATA BIT 4									
17	G3	I	GREEN DATA BIT 3									
18	G2	I	GREEN DATA BIT 2									
19	G1	I	GREEN DATA BIT 1									
20	G0	I	GREEN DATA BIT 0									
21	VSS	P	GROUND (VSS IS CONNECTED TO METAL HOUSING WITH CONDUCTIVE TAPE)									
22	R5	I	RED DATA BIT 5									
23	R4	I	RED DATA BIT 4									
24	R3	I	RED DATA BIT 3									
25	R2	I	RED DATA BIT 2									
26	R1	I	RED DATA BIT 1									
27	R0	I	RED DATA BIT 0									
28	DCLK	I	DOT DATA CLOCK									
29	VSS	P	GROUND (VSS IS CONNECTED TO METAL HOUSING WITH CONDUCTIVE TAPE)									

02101300-01-02

**EMERGING DISPLAY**  
TECHNOLOGIES CORPORATION

MODEL NO.  
E T 0 7 0 0 8 0 D H 6

VERSION  
4

PAGE  
13

PIN NO	SYMBOL	I/O	FUNCTION	
30	HSYNC	I	HORIZONTAL SYNC INPUT. INTERNALLY PULL HIGH.	DE & SYNC MODE SETTING DE MODE : ONLY ENB AND PIXEL CLOCK IS NECESSARY. SYNC MODE : ENB SHOULD BE CONNECTED TO VSS. HSYNC/VSYNC AND PIXEL CLOCK IS NECESSARY.
31	VSYNC	I	VERTICAL SYNC INPUT. INTERNALLY PULL HIGH.	
32	ENB	I	DATA ENABLE INPUT. INTERNALLY PULL LOW.	
33	ROTATE	I	WHEN ROTATE="H" THEN UD="H" LEVEL : OUT1→480 LR="L" LEVEL : OUT800→1 WHEN ROTATE="L" THEN UD="L" LEVEL : OUT480→1 (DEFAULT) LR="H" LEVEL : OUT1→800 (DEFAULT)	
34	NC	—	NON CONNECTION	
35	VSS	P	GROUND (VSS IS CONNECTED TO METAL HOUSING WITH CONDUCTIVE TAPE)	
36	VDD	P	POWER SUPPLY VOLTAGE	
37	YU	—	TOP PANEL	TOUCH PANEL
38	XR	—	RIGHT PANEL	
39	YD	—	BOTTOM PANEL	
40	XL	—	LEFT PANEL	

02101300-01-02

EMERGING DISPLAY TECHNOLOGIES CORPORATION	MODEL NO.	VERSION	PAGE
	ET070080DH6	4	14

11. POWER SUPPLY  
11.1 POWER SUPPLY FOR LCM

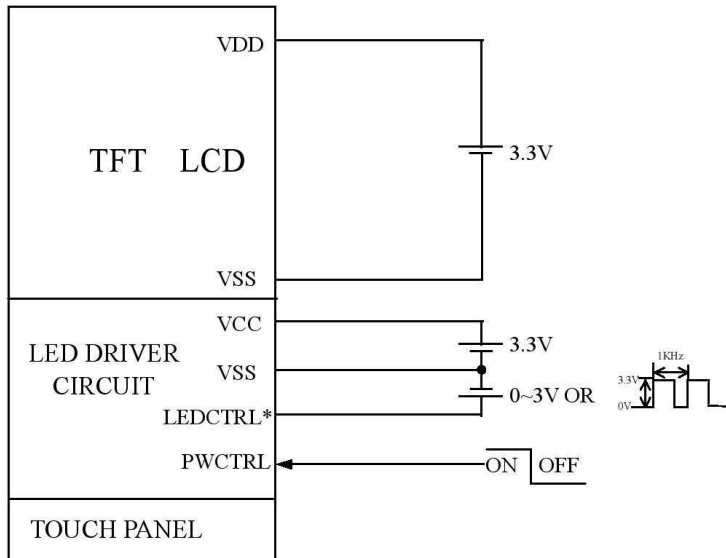

\* THE LEDCTRL CAN ALTERNATIVELY BE USED WITH A PWM, MINIMUM 1KHz FREQUENCY.

11.2 THE BRIGHTNESS CONTROLLED BY BACKLIGHT CURRENT OF LEDCTRL.

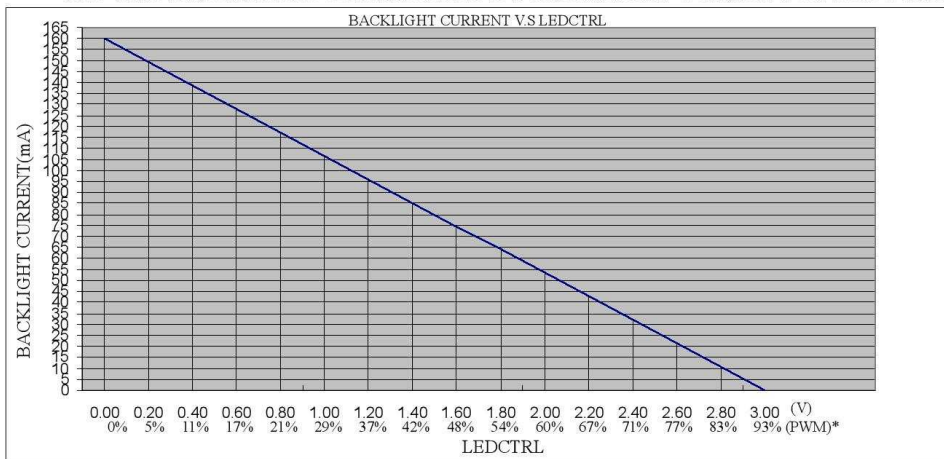

\*PWM IS BASED ON A 0~3.3V PWM SIGNAL RUNNING AT 1KHz

02101300-01-02

**EMERGING DISPLAY**  
TECHNOLOGIES CORPORATION

MODEL NO.	VERSION	PAGE
ET070080DH6	4	15

12. TOUCH PANEL SPECIFICATION

12.1 ELECTRICAL CHARACTERISTICS

Ta = 25°C

ITEM	CONDITION	SPEC.	UNIT
LINEARITY	—	< 1.5	%
TRANSMISSION	ASTM D1003	84±3	%
ACTIVATION FORCE	SILICON “ FINGER”	10~80	g
TERMINAL RESISTANCE	X AXIS	400 ~ 1200	Ω
	Y AXIS	100 ~ 600	
INSULATION RESISTANCE	DC25V	> 10	MΩ

12.2 ABSOLUTE MAXIMUM RATINGS :

ITEM	MIN.	TYP.	MAX.
OPERATING TEMPERATURE (Top)	-30°C	—	80°C
STORAGE TEMPERATURE (Tst)	-40°C	—	80°C
INPUT VOLTAGE ( V )	—	5	5.5

12.3 PRECAUTIONS IN USE OF TOUCH PANEL

12.3.1 PURPOSE :

IN ORDER TO PREVENT ACCIDENTAL USE AND PERFORMANCE DETERIORATION, PLEASE KEEP THE FOLLOWING PRECAUTIONS AND INHIBITED POINTS.

12.3.2 ITEM AND ILLUSTRATION :

( 1 ) STRUCTURE, AREA DEFINITION

THE STRUCTURE AND THE PERFORMANCE GUARANTEED AREA OF THIS TOUCH PANEL ARE DEFINED BELOW :

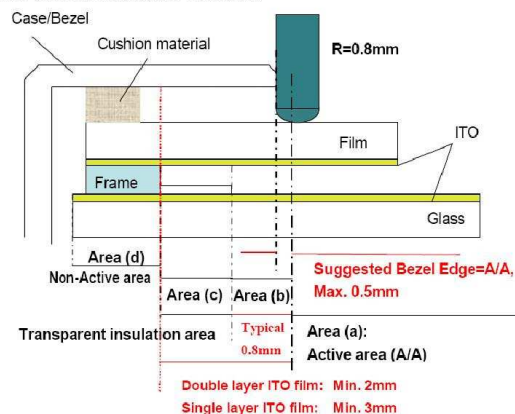

THE ABOVE FIGURE IS OUR DESIGN RULE OF TOUCH PANEL.  
IF IT CANNOT MEET YOUR REQUIREMENT, PLEASE CONTACT WITH OUR ENGINEERS FOR FURTHER DISCUSSION.

ABOVE FIGURE ILLUSTRATES THE RECOMMENDED BEZEL AND CUSHION DESIGN. IN ORDER TO PREVENT UNUSUAL PERFORMANCE DEGRADATION AND MALFUNCTION OF A TOUCH PANEL, PLEASE CARRY OUT THE SET CASE DESIGNING AND A TOUCH PANEL ASSEMBLING METHOD AFTER SURELY CONSIDERING THE DEFINITION OF EACH AREA ILLUSTRATED IN ABOVE FIGURE.

02101300-01-02



EMERGING DISPLAY TECHNOLOGIES CORPORATION	MODEL NO. ET070080DH6	VERSION 4	PAGE 16
--	--------------------------	--------------	------------

AREA(a) : ACTIVE AREA

THE ACTIVE AREA IS GUARANTEED THE POSITION DATA DETECTABLE PRECISION, OPERATION FORCE AND OTHER OPERATIONS. IT IS STRONGLY RECOMMENDED TO PLACE THE OPERATION BUTTON OR MENU KEYS WITHIN THE ACTIVE AREA. DUE TO STRUCTURE, THE ACTIVE AREA IS LESS DURABLE AT THE EDGE OR CLOSE TO THE EDGE.

AREA(b) : OPERATION NON-GUARANTEED AREA

THIS AREA DOES NOT GUARANTEE A TOUCH PANEL OPERATION AND ITS FUNCTION. WHEN THIS AREA IS PRESSED, TOUCH PANEL SHOWS DEGRADATION OF ITS PERFORMANCE AND DURABILITY SUCH AS A PEN SLIDING DURABILITY BECOMES ABOUT ONE-TENTH COMPARED WITH THE ACTIVE AREA (AREA-(A) AS GUARANTEED AREA) AND ITS OPERATION FORCE REQUIRES ABOUT DOUBLE. ABOUT 0.5 MM OUTSIDE FROM A BOUNDARY OF THE ACTIVE AREA CORRESPONDS TO THIS AREA.

AREA(c) : PRESSING PROHIBITION AREA

THE AREA WHICH FORBIDS PRESSING, BECAUSE AN EXCESSIVE LOAD IS APPLIED TO A TRANSPARENT ELECTRODE (ITO) AND A SERIOUS DAMAGE IS GIVEN TO A TOUCH PANEL FUNCTION BY PRESSING.

AREA(d) : NON-ACTIVE AREA

THE AREA DOES NOT ACTIVATE EVEN IF PRESSED.

( 2 ) CAUTIONS FOR INSTALLING AND ASSEMBLING

- ( i ) DO NOT GIVE EXCESSIVE STRAIN TO THE PRODUCT.
- ( ii ) FLEXIBLE PATTERN CABLE IS CONNECTED TO THE BODY BY THERMAL PRESSURE METHOD. SO, DO NOT APPLY EXCESSIVE FORCES TO THE FLEXIBLE PATTERN. DO NOT ADD AN EXCESSIVE FORCE TO A FPC(FLEX TAIL) THAT MAKES PEELING OFF OF THE FPC FROM THE PRODUCT. DO NOT FIX, ADHERE OR MOUNT ANY ADDITIONAL GOODS ON THE FPC SUCH AS ADDITIONAL FILM/PLATE ON THE FPC, BECAUSE SUCH ADDITIONAL GOODS WILL APPLY A STRESS AT THE FPC BONDING AREA. IT MAY AFFECT THE CONDUCTIVITY OF FPC WITH TOUCH PANEL.
- ( iii ) IN ORDER NOT TO APPLY LOAD ON THE DISPLAY, PROVIDE A CLEARANCE OF AT LEAST 0.3MM BETWEEN THE PRODUCT AND DISPLAY.
- ( iv ) WE RECOMMEND THE DESIGN OF A CASE OR BEZEL SHOULD COVERS THE BOUNDARY OF THE ACTIVE AREA INSIDE IN ORDER TO PREVENT AN OPERATION AT OUTSIDE OF THE ACTIVE AREA WHICH CAN NOT GUARANTEE THE FUNCTION OR DURABILITY (REFER TO ITEM 5.1.2. STRUCTURE, AREA DEFINITION).  
BEZEL'S EDGE PART MAY GUIDE THE PEN SLIDING ON THE SAME POSITION REPEATEDLY. IF THE BEZEL IS PLACED OUTSIDE OF THE ACTIVE AREA, IT MAY CAUSE THE DAMAGE OF THE ITO FILM.

02101300-01-02

EMERGING DISPLAY TECHNOLOGIES CORPORATION	MODEL NO. ET070080DH6	VERSION 4	PAGE 17
--	--------------------------	--------------	------------

- (v) PRESSING INSIDE OF BOUNDARY OF THE FRAME(PART (A) AS SHOWN IN BELOW) MAY CAUSES FAULT OPERATION, SO PLEASE DESIGN TO AVOID PRESSING OF TOUCH PANEL AT PART (A) SUCH AS HAVING GASKET/CUSHION AT PART (C). PARTICULARLY THE AREA (B) SHALL BE FREE FROM BURR. THE GASKET/CUSHION MATERIAL AT THE PART (C) SHOULD NOT BE EXCEEDED TO INSIDE OF THE BOUNDARY OF THE FRAME.

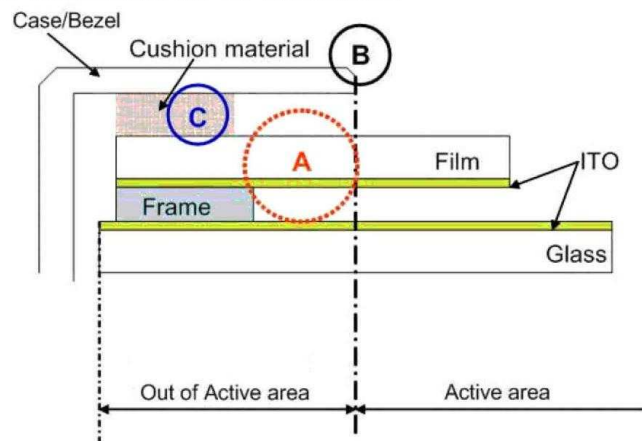

- (vi) TO PREVENT GIVING DISTORTION TO THE FILM OF THE PRODUCT AND PEELING OFF OF THE FILM FROM THE PRODUCT, DO NOT FIX THE FILM AND A SET CASE OR A SHOCK ABSORBING MATERIAL ADHERED TO A SET CASE BY ADHESION.
- (vii) WIPE OFF THE STAIN ON THE PRODUCT BY USING SOFT CLOTH MOISTENED WITH ETHANOL. TAKE CARE NOT TO ALLOW ETHANOL TO SOAK INTO THE JOINT OF UPPER FILM AND BOTTOM GLASS. IT MAY OTHERWISE CAUSE PEELING OR DEFECTIVE OPERATION. DO NOT USE ANY ORGANIC SOLVENT OR DETERGENT OTHER THAN ETHANOL.
- (viii) THE CORNERS OF THE PRODUCT ARE NOT CHAMFERED AND ARE SHARP. WHEN POSITIONING AND FIXING THE PRODUCT ON THE CASE, PROVIDE A ROUND PART ON THE CORNER OF THE CASE SO AS NOT TO APPLY LOAD ON THE CORNER OF THE TRANSPARENT TOUCH PANEL.
- (ix) DO NOT PRESS THE FILM OF THE PRODUCT WHEN THIS PRODUCT IS BUILT INTO A SET.
- (3) CAUTIONS FOR OPERATION
- (i) OPERATE IT WITH A POLYACETAL PEN (TIP R0.8 OR OVER) OR A BELLY OF A FINGER WITHOUT APPLYING EXCESSIVE LOAD. NEVER USE ANY MECHANICAL PENCILS, BALL POINT PENS AND HARD FINGERTIPS WHOSE TIP IS HARD FOR INPUT, OTHERWISE MALFUNCTIONS MAY RESULT.

02101300-01-02



EMERGING DISPLAY  
TECHNOLOGIES CORPORATION

MODEL NO.

ET070080DH6

VERSION

4

PAGE

18

(ii) THE INPUT POSITION MAY BE FLUCTUATED A LITTLE THROUGH LONG-TIME USE. IT IS DESIRABLE TO PROVIDE A ZERO-ADJUSTMENT FUNCTION BY USING A CIRCUIT AND SOFTWARE.

(iii) OPERATION AT THE OUT OF ACTIVE AREA IS OUT OF OUR GUARANTEE. IT CAUSES A SERIOUS DAMAGE OF A TRANSPARENT ELECTRODE. DO NOT OPERATE AT THE OUT OF ACTIVE AREA.

(iv) IN CASE OF CLEANING THE PART OF THE CASE BOUNDARY OF ACCOMPLISHED SET, USE A SOFT CLOTH WITH A FINGER BERRY OR A COTTON BUD. DO NOT CLEAN WITH A THING OTHER THAN THE FINGER SUCH AS HARD OR SHARP EDGES LIKE A FINGER NAIL ETC. ON THE CLOTH, BECAUSE IT CAUSE TRANSPARENT CONDUCTIVE FILM CRACKS. PLEASE ADVISE THIS PROHIBITION TO YOUR LAST CUSTOMERS.

#### 12.4 DURABILITY

##### 12.4.1 STYLUS HITTING :

ONE MILLION TIMES OR OVER  
NO DAMAGE ON FILM SURFACE  
PEN : R8 mm SILICON RUBBER  
LOAD : 250g  
FREQUENCY : 240 times/min  
MEASUREMENT POSITION:  
1 POINT OF TOUCH PANEL ACTIVE AREA  
REPEATED : OVER 1,000,000 TIMES

##### 12.4.2 PEN TOUCH SLIDING DURABILITY :

100,000 TIMES OR OVER  
WRITING WITH R0.8mm PLASTIC STYLUS PEN; WRITING FORCE 150g  
IN ACTIVE AREA.  
SPEED IS 60mm/sec.

02101300-01-02

EMERGING DISPLAY TECHNOLOGIES CORPORATION	MODEL NO.	VERSION	PAGE
	ET070080DH6	4	19

12.5 STEEL BALL DROP TEST

BY USING F9mm STEEL BALL FROM THE HEIGHT OF 30cm AND FALLING ON TOUCH PANEL SURFACE, MUST PASS BELOW CONDITIONS :  
 APPEARANCE : THE APPEARANCE WITHOUT ANY CHANGE, INCLUDING THE PANEL BROKEN.

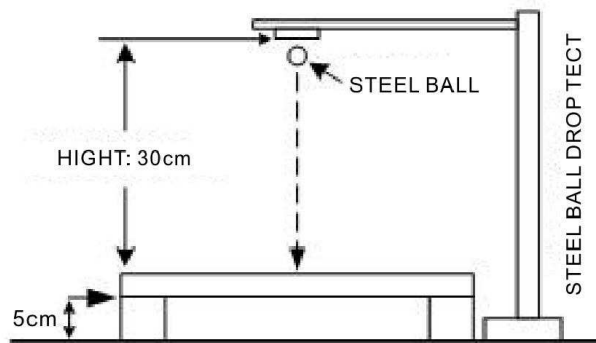

12.6 APPEARANCE INSPECTION

PURPOSE :  
 TO ESTABLISH APPEARANCE STANDARD AND MAINTAIN PRODUCT QUALITY ◦  
 SCOPE :  
 TOUCH PANEL VIEW AREA WITHIN TOUCH PANEL ◦

12.6.1 RULE :

- INSPECTION CONDITION
- (A) ENVIRONMENTAL LUMINANCE : 500 LUX ◦
  - (B) DISTANCE BETWEEN HUMAN EYES AND PANEL : 30 CM  
 (PANEL MUST BE TESTED UNDER LIGHT TRANSPARENT) ◦
  - (C) VISUAL ANGEL : > 60° ◦
  - (D) LIGHT SOURCE : FLUORESCENT LIGHT SOURCE ◦

12.6.2 JUDGE CRITERION :

JUDGEMENT UNDER ABOVE MENTIONED CRITERION (PANEL MUST BE TESTED UNDER LIGHT TRANSPARENT), TESTING GOODS DEFECT CAN BE VISIBLE WITHIN 10 SECONDS, WHICH WILL BE JUDGED AS MAJOR DEFECTS ◦

SAMPLING STANDARD :

THE SAMPLING STANDARD WILL BE CONFIRMED BY BOTH OF EDT AND CUSTOMER.

02101300-01-02

EMERGING DISPLAY TECHNOLOGIES CORPORATION	MODEL NO.	VERSION	PAGE
	ET070080DH6	4	20

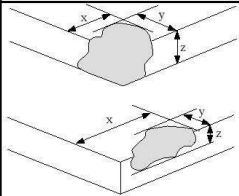
DEFECT ITEM	SPECIFICATIONS		ALLOWED /REJECT	REMARK
OPAQUE SPOT	D ≤ 0.10		NOT COUNT AS A DEFECT	
	0.10 < D ≤ 0.30		ACCEPT	SEE REMARK
	D > 0.30		REJECT	
HOLLOW OR PROTUBERANCE SPOT	D ≤ 0.4		ACCEPT	
	D > 0.4		REJECT	
SCRATCH	UNABLE TO MEASURE		NOT COUNT AS A DEFECT FOR ANY	
	WIDTH		LENGTH	
	W ≤ 0.025		L ≤ 20	SEE REMARK
	0.025 < W ≤ 0.05		L ≤ 10	
	W > 0.05		REJECT	
LINT (FIBROUS MATERIAL, HAIR, ADHESIVE, LINT)	W ≤ 0.025		L ≤ 10	SEE REMARK
	0.025 < W ≤ 0.05		L ≤ 5	SEE REMARK
	W > 0.05		REJECT	
CHIP ON GLASS	CORNER	X ≤ 1.0mm AND Y ≤ 1.0mm AND Z=GLASS THICKNESS	ACCEPT	
	EDGE	X ≤ 6.0mm AND Y ≤ 2.0mm AND Z < GLASS THICKNESS		

D: DIAMETER; W: WIDTH; L: LENGTH UNIT: mm

REMARK:

- IF THE DISTANCE BETWEEN DEFECTS IS < 10 mm, THE PRODUCT SHALL BE REJECTED. IT IS ACCEPTED IF THE DISTANCE BETWEEN DEFECTS ≥ 10 mm.
- THE ABOVE DEFECT SPECIFICATIONS ARE DEFINED IN THE ACTIVE AREA. IF THERE IS ANY DEFECT THAT IS BLACK OR COLORED LINT OR DOT LOCATED IN THE VIEWING AREA, IT SHALL BE DEFINED AS THE ACTIVE AREA SPECS. FOR TRANSPARENT OR TRANSLUCENT TYPE OF DEFECT LOCATED AT NON-ACTIVE AREA IS ACCEPTABLE IF ITS DIAMETER IS LESS THAN 0.5mm.

02101300-01-02

EMERGING DISPLAY TECHNOLOGIES CORPORATION	MODEL NO. ET070080DH6	VERSION 4	PAGE 21
--	--------------------------	--------------	------------

13. INSPECTION CRITERION

13.1 APPLICATION

This inspection standard is to be applied to the LCD module delivered from EMERGING DISPLAY TECHNOLOGIES CORP.( E.D.T ) to customers

13.2 INSPECTION CONDITIONS

13.2.1 (1)Observation Distance : 35cm±5cm

(2)View Angle :

Non-operation Condition : ±5°(perpendicular to LCD panel surface)

Operation Condition : ±45° (perpendicular to LCD panel surface)

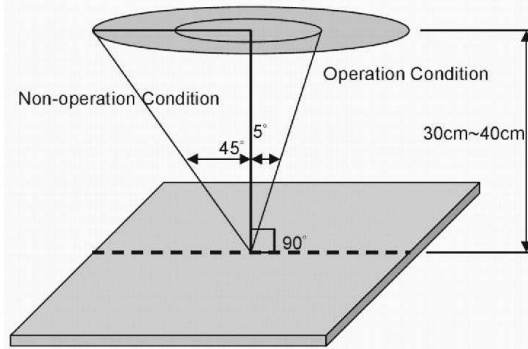

13.2.2 Environment Conditions :

Ambient Temperature		20°C~25°C
Ambient Humidity		65±20%RH
Ambient Illumination	Cosmetic Inspection	More than 600Lux
	Functional Inspection	300~500 Lux

13.2.3 Inspection lot

Quantity per delivery lot for each model

13.2.4 Inspection method

A sampling inspection shall be made according to the following provisions to judge The acceptability

(a)Applicable standard : MIL-STD-105E

Normal inspection, single sampling

Level II

(b)AQL : Major defect : AQL 0.65

Minor defect : AQL 1.0

02101300-01-02

EMERGING DISPLAY TECHNOLOGIES CORPORATION	MODEL NO. ET070080DH6	VERSION 4	PAGE 22
--	--------------------------	--------------	------------

13.3 INSPECTION STANDARDS

13.3.1 VISUAL DEFECTS CLASSIFICATION

TYPE OF DEFECT	INSPECTION ITEM	DEFECT FEATURE	AQL
MAJOR DEFECT	1.DISPLAY ON	<ul style="list-style-type: none"> <li>• DEFECT TO MISS SPECIFIED DISPLAY FUNCTION, FOR ALL AND SPECIFIED DOTS EX: DISCONNECTION, SHORT CIRCUIT ETC</li> </ul>	0.65
	2.BACKLIGHT	<ul style="list-style-type: none"> <li>• NO LIGHT</li> <li>• FLICKERING AND OTHER ABNORMAL ILLUMINATION</li> </ul>	
	3.DIMENSIONS	<ul style="list-style-type: none"> <li>• SUBJECT TO INDIVIDUAL ACCEPTANCE SPECIFICATIONS</li> </ul>	
MINOR DEFECT	1.DISPLAY ZONE	<ul style="list-style-type: none"> <li>• BLACK/WHITE SPOT</li> <li>• BUBBLES ON POLARIZER</li> <li>• NEWTON RING</li> <li>• BLACK/WHITE LINE</li> <li>• SCRATCH</li> <li>• CONTAMINATION</li> <li>• LEVER COLOR SPREED</li> </ul>	1.0
	2.BEZEL ZONE	<ul style="list-style-type: none"> <li>• STAINS</li> <li>• SCRATCHES</li> <li>• FOREIGN MATTER</li> </ul>	
	3.SOLDERING	<ul style="list-style-type: none"> <li>• INSUFFICIENT SOLDER</li> <li>• SOLDERED IN INCORRECT POSITION</li> <li>• CONVEX SOLDERING SPOT</li> <li>• SOLDER BALLS</li> <li>• SOLDER SCRAPS</li> </ul>	
	4.DISPLAY ON (ALL ON)	<ul style="list-style-type: none"> <li>• LIGHT LINE</li> </ul>	

02101300-01-02

EMERGING DISPLAY TECHNOLOGIES CORPORATION	MODEL NO. ET070080DH6	VERSION 4	PAGE 23
--	--------------------------	--------------	------------

13.3.2 MODULE DEFECTS CALSSIFICATION

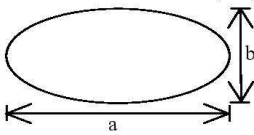
NO.	ITEM	CRITERIA												
1.	DISPLAY ON INSPECTION	(1)INCORRECT PATTERN (2)MISSING SEGMENT (3)DIM SEGMENT (4)OPERATING VOLTAGE BEYOND SPEC												
2.	OVERALL DIMENSIONS	(1)OVERALL DIMENSION BEYOND SPEC												
3.	DOT DEFECT	(1) INSPECTION PATTERN: FULL WHITE, FULL BLACK, RED, GREEN AND BLUE SCREENS. (2) <table border="1"> <thead> <tr> <th>ITEMS</th> <th>ACCEPTABLE COUNT</th> </tr> </thead> <tbody> <tr> <td>BRIGHT DOT</td> <td><math>N \leq 3</math></td> </tr> <tr> <td>DARK DOT</td> <td><math>N \leq 5</math></td> </tr> <tr> <td>TOAL BRIGHT AND DARK DOTS</td> <td><math>N \leq 5</math></td> </tr> </tbody> </table> <p>NOTE : 1. THE DEFINITION OF DOT : THE SIZE OF A DEFECTIVE DOT OVER 1/2 OF WHOLE DOT IS REGARDED AS ONE DEFECTUVE DOT. 2. BRIGHT DOT : DOTS APPEAR BRIGHT AND UNCHANGED IN SIZE IN WHICH LCD PANEL IS DISPLAYING UNDER BLACK PATTERN. 3. DARK DOT : DOTS APPEAR DARK AND UNCHANGED IN SIZE IN WHICH LCD PANEL IS DISPLAYING UNDER PURE RED, GREEN, BLUE PICTURE.</p>	ITEMS	ACCEPTABLE COUNT	BRIGHT DOT	$N \leq 3$	DARK DOT	$N \leq 5$	TOAL BRIGHT AND DARK DOTS	$N \leq 5$				
ITEMS	ACCEPTABLE COUNT													
BRIGHT DOT	$N \leq 3$													
DARK DOT	$N \leq 5$													
TOAL BRIGHT AND DARK DOTS	$N \leq 5$													
4.	FOREIGN BLACK/WHITE/ BRIGHT LINE/ SCRATCH OF VIEWING AREA	<table border="1"> <thead> <tr> <th>LENGTH : L</th> <th>WIDTH : W</th> <th>PERMISSIBLE NO.</th> </tr> </thead> <tbody> <tr> <td><math>L \leq 0.3</math></td> <td><math>W \leq 0.05</math></td> <td>IGNORE</td> </tr> <tr> <td><math>0.3 &lt; L \leq 2.5</math></td> <td><math>0.05 &lt; W \leq 0.1</math></td> <td>4</td> </tr> <tr> <td><math>2.5 &lt; L</math></td> <td><math>0.1 &lt; W</math></td> <td>NONE</td> </tr> </tbody> </table> <p>WIDTH : W mm, LENGH : L mm</p>	LENGTH : L	WIDTH : W	PERMISSIBLE NO.	$L \leq 0.3$	$W \leq 0.05$	IGNORE	$0.3 < L \leq 2.5$	$0.05 < W \leq 0.1$	4	$2.5 < L$	$0.1 < W$	NONE
LENGTH : L	WIDTH : W	PERMISSIBLE NO.												
$L \leq 0.3$	$W \leq 0.05$	IGNORE												
$0.3 < L \leq 2.5$	$0.05 < W \leq 0.1$	4												
$2.5 < L$	$0.1 < W$	NONE												
5.	FOREIGN MATTER \ BLACK SPOTS \ WHITE SPOTS \ DENT (INCLUDING LIGHT LEAKAGE DUE TO POLARIZING PLATES PINHOLES, ETC.)	<table border="1"> <thead> <tr> <th>AVERAGE DIAMETER (mm): D</th> <th>NUMBER OF PIECES PERMITTED</th> </tr> </thead> <tbody> <tr> <td><math>D \leq 0.15</math></td> <td>IGNORE</td> </tr> <tr> <td><math>0.15 &lt; D \leq 0.5</math></td> <td>4</td> </tr> <tr> <td><math>0.5 &lt; D</math></td> <td>NONE</td> </tr> </tbody> </table> <p>NOTE : DIAMETER <math>D=(a+b)/2</math></p> 	AVERAGE DIAMETER (mm): D	NUMBER OF PIECES PERMITTED	$D \leq 0.15$	IGNORE	$0.15 < D \leq 0.5$	4	$0.5 < D$	NONE				
AVERAGE DIAMETER (mm): D	NUMBER OF PIECES PERMITTED													
$D \leq 0.15$	IGNORE													
$0.15 < D \leq 0.5$	4													
$0.5 < D$	NONE													

02101300-01-02

EMERGING DISPLAY TECHNOLOGIES CORPORATION	MODEL NO. ET070080DH6	VERSION 4	PAGE 24
--	--------------------------	--------------	------------

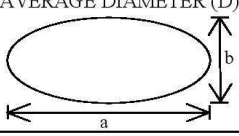
NO.	ITEM	CRITERIA		
		AVERAGE DIAMETER (mm) : D	NUMBER OF PIECES PERMITTED	
6.	BUBBLES OF POLARIZER /DIRT/CF FAIL /SURFACE STAINS	BUBBLE ON THE POLARIZER	D ≤ 0.25	IGNORE
			0.25 < D ≤ 0.5	N ≤ 5
			0.5 < D	NOTE
		SURFACE STATUS	D < 0.1 mm	IGNORE
			0.1 < D ≤ 0.3mm	N ≤ 3
		CF FAIL / SPOT	D < 0.1 mm	IGNORE
		0.1 < D ≤ 0.3mm	N ≤ 3	
		NOTE : (1)POLARIZER BUBBLE IS DEFINED AS THE BUBBLE APPEARS ON ACTIVE DISPLAY AREA. THE DEFECT OF POLARIZER BUBBLE SHALL BE IGNORED IF THE POLARIZER BUBBLE APPEARS ON THE OUTSIDE OF ACTIVE DISPLAY AREA. (2)THE EXTRANEIOUS SUBSTANCE IS DEFINED AS IT CAN BE OBSERVED WHEN THE MODULE IS POWER ON. (3)THE DEFINITION OF AVERAGE DIAMETER, D IS DEFINED AS FOLLOWING. AVERAGE DIAMETER (D)=(a+b)/2 		
7.	LINE DEFECT ON DISPLAY	OBVIOUS VERTICAL OR HORIZONTAL LINE DEFECT IS NOT ALLOW		
8.	MURA ON DISPLAY	IT'S OK IF MURA IS SLIGHT VISIBLE THROUG 6% ND FILTER		
9.	UNEVEN COLOR SPREAD, COLORATION	(1)TO BE DETERMINED BASED UPON THE STANDARD SAMPLE.		
10.	BEZEL APPEARANCE	(1)BEZEL MAY NOT HAVE RUST, BE DEFORMED OR HAVE FINGER PRINTS STAINS OF OTHER CONTAMINATION. (2)BEZEL MUST COMPLY WITH JOB SPECIFICATIONS.		
11.	PCB	(1)THERE MAY NOT BE MORE THAN 2mm OF SEALANT OUTSIDE THE SEAL AREA ON THE PCB, AND THERE SHOULD BE NO MORE THAN THREE PLACES. (2)NO OXIDATION OR CONTAMINATION PCB TERMINALS. (3)PARTS ON PCB MUST BE THE SAME AS ON THE PRODUCTION CHARACTERISTIC CHART. THERE SHOULD BE NO WRONG PARTS, MISSING PARTS OR EXCESS PARTS. (4)THE JUMPER ON THE PCB SHOULD CONFORM TO THE PRODUCT CHARACTERISTIC CHART. (5)IF SOLDER GETS ON BEZEL TAB PADS, LED PAD, ZEBRA PAD OR SCREW HOLD PAD, MAKE SURE IT IS SMOOTHED DOWN.		

02101300-01-02

EMERGING DISPLAY  
TECHNOLOGIES CORPORATION

MODEL NO.  
ET070080DH6

VERSION  
4

PAGE  
25

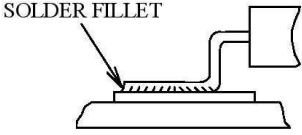
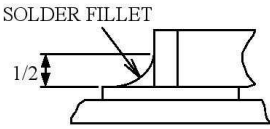
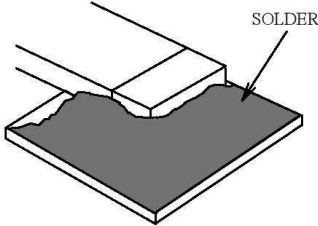
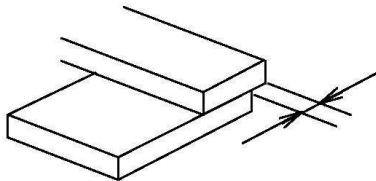
NO.	ITEM	CRITERIA
12.	SOLDERING	<p>(1)NO SOLDERING FOUND ON THE SPECIFIED PLACE (2)INSUFFICIENT SOLDER (a)LSI, IC A POOR WETTING OF SOLDER IS BETWEEN LOWER BEND OR "HEEL" OF LEAD AND PAD</p>  <p>(b)CHIP COMPONENT · SOLDER IS LESS THAN 50% OF SIDES AND FRONT FACE WETTING</p>  <p>• SOLDER WETS 3 SIDES OF TERMINAL, BUT LESS THAN 25% OF SIDES AND FRONT SURFACE AREA ARE COVERED</p>  <p>(3)PARTS ALIGMENT (a)LSI, IC LEAD WIDTH IS MORE THAN 50% BEYOND PAD OUTLINE</p> 

02101300-01-02

EMERGING DISPLAY TECHNOLOGIES CORPORATION	MODEL NO. ET070080DH6	VERSION 4	PAGE 26
--	--------------------------	--------------	------------

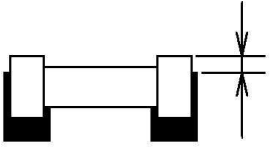
NO.	ITEM	CRITERIA
12.	SOLDERING	<p>(b)CHIP COMPONENT COMPONENT IS OFF CENTER, AND MORE THAN 50% OF THE LEADS IS OFF THE PAD OUTLINE</p>  <p>(4)NO UNMELTED SOLDER PASTE MAY BE PRESENT ON THE PCB.                      (5)NO COLD SOLDER JOINTS, MISSING SOLDER CONNECTIONS, OXIDATION OR ICICLE.                      (6)NO RESIDUE OR SOLDER BALLS ON PCB.                      (7)NO SHORT CIRCUITS IN COMPONENTS ON PCB.</p>
13.	BACKLIGHT	<p>(1)NO LIGHT                      (2)FLICKERING AND OTHER ABNORMAL ILLUMINATION                      (3)SPOTS OR SCRATCHES THAT APPEAR WHEN LIT MUST BE JUDGED USING LCD SPOT, LINES AND CONTAMINATION STANDARDS.                      (4)BACKLIGHT DOESN'T LIGHT OR COLOR IS WRONG.</p>
14.	GENERAL APPEARANCE	<p>(1)NO OXIDATION, CONTAMINATION, CURVES OR, BENDS ON INTERFACE PIN (OLB) OF TCP.                      (2)NO CRACKS ON INTERFACE PIN (OLB) OF TCP.                      (3)NO CONTAMINATION, SOLDER RESIDUE OR SOLDER BALLS ON PRODUCT.                      (4)THE IC ON THE TCP MAY NOT BE DAMAGED, CIRCUITS.                      (5)THE UPPERMOST EDGE OF THE PROTECTIVE STRIP ON THE INTERFACE PIN MUST BE PRESENT OR LOOK AS IF IT CAUSE THE INTERFACE PIN TO SEVER.                      (6)THE RESIDUAL ROSIN OR TIN OIL OF SOLDERING (COMPONENT OR CHIP COMPONENT) IS NOT BURNED INTO BROWN OR BLACK COLOR.                      (7)SEALANT ON TOP OF THE ITO CIRCUIT HAS NOT HARDENED.                      (8)PIN TYPE MUST MATCH TYPE IN SPECIFICATION SHEET.                      (9)LCD PIN LOOSE OR MISSING PINS.                      (10)PRODUCT PACKAGING MUST THE SAME AS SPECIFIED ON PACKAGING SPECIFICATION SHEET.                      (11)PRODUCT DIMENSION AND STRUCTURE MUST CONFORM TO PRODUCT SPECIFICATION SHEET.                      (12)THE APPEARANCE OF HEAT SEAL SHOULD NOT ADMIT ANY DIRT AND BREAK.</p>

02101300-01-02

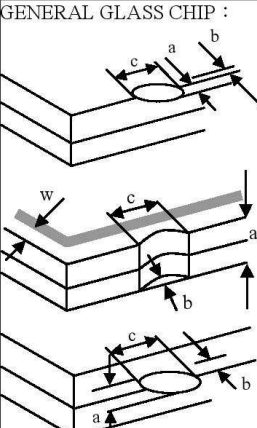
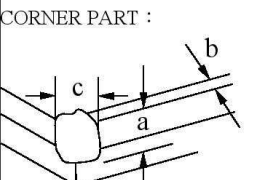
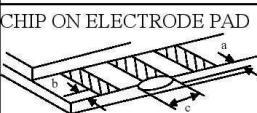
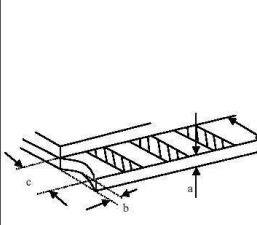
NO.	ITEM	CRITERIA									
15.	CRACKED GLASS	<p>THE LCD WITH EXTENSIVE CRACK IS NOT ACCEPTABLE</p> <p>GENERAL GLASS CHIP :</p>  <table border="1"> <thead> <tr> <th>a</th> <th>b</th> <th>c</th> </tr> </thead> <tbody> <tr> <td><math>\leq t/2</math></td> <td>&lt; VIEWING AREA</td> <td><math>\leq 1/8X</math></td> </tr> <tr> <td><math>t/2 &gt; a \leq 2t</math></td> <td><math>\leq W/2</math></td> <td><math>\leq 1/8X</math></td> </tr> </tbody> </table> <p>*W=DISTANCE BETWEEN SEALANT AREA AND LCD PANEL EDGE X = LCD SIDE LENGTH t = GLASS THICKNESS</p>	a	b	c	$\leq t/2$	< VIEWING AREA	$\leq 1/8X$	$t/2 > a \leq 2t$	$\leq W/2$	$\leq 1/8X$
		a	b	c							
		$\leq t/2$	< VIEWING AREA	$\leq 1/8X$							
		$t/2 > a \leq 2t$	$\leq W/2$	$\leq 1/8X$							
<p>CORNER PART :</p>  <table border="1"> <thead> <tr> <th>a</th> <th>b</th> <th>c</th> </tr> </thead> <tbody> <tr> <td><math>\leq t/2</math></td> <td>&lt; VIEWING AREA</td> <td><math>\leq 1/8X</math></td> </tr> <tr> <td><math>&gt; t/2, \leq 2t</math></td> <td><math>\leq W/2</math></td> <td><math>\leq 1/8X</math></td> </tr> </tbody> </table> <p>*W=DISTANCE BETWEEN SEALANT AREA AND LCD PANEL EDGE X = LCD SIDE LENGTH t = GLASS THICKNESS</p>	a	b	c	$\leq t/2$	< VIEWING AREA	$\leq 1/8X$	$> t/2, \leq 2t$	$\leq W/2$	$\leq 1/8X$		
a	b	c									
$\leq t/2$	< VIEWING AREA	$\leq 1/8X$									
$> t/2, \leq 2t$	$\leq W/2$	$\leq 1/8X$									
<p>CHIP ON ELECTRODE PAD</p>  <table border="1"> <thead> <tr> <th>a</th> <th>b</th> <th>c</th> </tr> </thead> <tbody> <tr> <td><math>\leq t</math></td> <td><math>\leq 0.5\text{mm}</math></td> <td><math>\leq 1/8X</math></td> </tr> </tbody> </table> <p>* X=LCD SIDE WIDTH t=GLASS THICKNESS</p>	a	b	c	$\leq t$	$\leq 0.5\text{mm}$	$\leq 1/8X$					
a	b	c									
$\leq t$	$\leq 0.5\text{mm}$	$\leq 1/8X$									
 <table border="1"> <thead> <tr> <th>a</th> <th>b</th> <th>c</th> </tr> </thead> <tbody> <tr> <td><math>\leq t</math></td> <td><math>\leq 1/8X</math></td> <td><math>\leq L</math></td> </tr> </tbody> </table> <p>*X=LCD SIDE WIDTH t = GLASS THICKNESS L=ELECTRODE PAD LENGTH ①IF GLASS CHIPPING THE ITO TERMINAL, OVER 2/3 OF THE ITO MUST REMAIN AND BE, INSPECTED ACCORDING TO ELECTRODE TERMINAL SPECIFICATIONS ②IF THE PRODUCT WILL BE HEAT SEALED BY THE CUSTOMER, THE ALIGNMENT MARK MUST NOT BE DEMAGED</p>	a	b	c	$\leq t$	$\leq 1/8X$	$\leq L$					
a	b	c									
$\leq t$	$\leq 1/8X$	$\leq L$									

02101300-01-02



**EMERGING DISPLAY**  
TECHNOLOGIES CORPORATION

MODEL NO.  
ET070080DH6

VERSION  
4

PAGE  
28

13.4 RELIABILITY TEST

13.4.1 STANDARD SPECIFICATIONS FOR RELIABILITY OF LCD MODULE

NO	ITEM	DESCRIPTION
1	HIGH TEMPERATURE OPERATION	THE SAMPLE SHOULD BE ALLOWED TO STAND AT +70°C FOR 240 HRS
2	LOW TEMPERATURE OPERATION	THE SAMPLE SHOULD BE ALLOWED TO STAND AT -20°C FOR 240 HRS
3	HIGH TEMPERATURE STORAGE	THE SAMPLE SHOULD BE ALLOWED TO STAND AT +80°C FOR 240 HRS
4	LOW TEMPERATURE STORAGE	THE SAMPLE SHOULD BE ALLOWED TO STAND AT -30°C FOR 240 HRS
5	HIGH TEMP / HUMIDITY TEST STORAGE	THE SAMPLE SHOULD BE ALLOWED TO STAND AT 60°C, 90% RH 240 HRS
6	THERMAL SHOCK (NOT OPERATED)	THE SAMPLE SHOULD BE ALLOWED TO STAND THE FOLLOWING 10 CYCLES OF OPERATION: -30°C FOR 30 MINUTES ~ +80°C FOR 30 MINUTES
7	ESD (ELECTROSTATIC DISCHARGE) (NOT OPERATED)	AIR DISCHARGE ± 12KV CONTACT DISCHARGE ± 8KV

NOTE (1) : THE TEST SAMPLES HAVE RECOVERY TIME FOR 2 HOURS AT ROOM TEMPERATURE BEFORE THE FUNCTION CHECK. IN THE STANDARD CONDITIONS, THERE IS NO DISPLAY FUNCTIONING ISSUE OCCURRED.

13.5 TESTING CONDITIONS AND INSPECTION CRITERIA

FOR THE FINAL TEST THE TESTING SAMPLE MUST BE STORED AT ROOM TEMPERATURE FOR 24 HOURS, AFTER THE TESTS LISTED IN TABLE 13.5, STANDARD SPECIFICATIONS FOR RELIABILITY HAVE BEEN EXECUTED IN ORDER TO ENSURE STABILITY.

NO	ITEM	TEST MODEL	INSPECTION CRITERIA
1	CURRENT CONSUMPTION	REFER TO SPECIFICATION	THE CURRENT CONSUMPTION SHOULD CONFORM TO THE PRODUCT SPECIFICATION.
2	CONTRAST	REFER TO SPECIFICATION	AFTER THE TESTS HAVE BEEN EXECUTED, THE CONTRAST MUST BE LARGER THAN HALF OF ITS INITIAL VALUE PRIOR TO THE TESTS.
3	APPEARANCE	VISUAL INSPECTION	DEFECT FREE

02101300-01-02

**EMERGING DISPLAY**  
TECHNOLOGIES CORPORATION

MODEL NO.	VERSION	PAGE
ET070080DH6	4	29

13.6 OPERATION

- 13.6.1 DO NOT CONNECT OR DISCONNECT MODULES TO OR FROM THE MAIN SYSTEM WHILE POWER IS BEING SUPPLIED .
- 13.6.2 USE THE MODULE WITHIN SPECIFIED TEMPERATURE ; LOWER TEMPERATURE CAUSES THE RETARDATION OF BLINKING SPEED OF THE DISPLAY ; HIGHER TEMPERATURE MAKES OVERALL DISPLAY DISCOLOR. WHEN THE TEMPERATURE RETURNS TO NORMALITY, THE DISPLAY WILL OPERATE NORMALLY .
- 13.6.3 ADJUST THE LC DRIVING VOLTAGE TO OBTAIN THE OPTIMUM CONTRAST.
- 13.6.4 POWER ON SEQUENCE INPUT SIGNALS SHOULD NOT BE SUPPLIED TO LCD MODULE BEFORE POWER SUPPLY VOLTAGE IS APPLIED AND REACHES THE SPECIFIED VALUE .  
IF ABOVE SEQUENCE IS NOT FOLLOWED , CMOS LSIS OF LCD MODULES MAY BE DAMAGED DUE TO LATCH - UP PROBLEM .
- 13.6.5 NOT ALLOWED TO INFLICT ANY EXTERNAL STRESS AND TO CAUSE ANY MECHANICAL INTERFERENCE ON THE BENDING AREA OF FPC DURING THE TAIL BENDING BACKWARDS!  
DO NOT STRESS FPC AND IC ON THE MODULE!

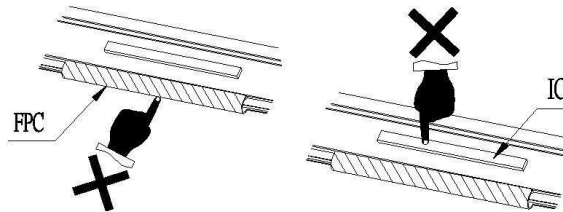

02101300-01-02



EMERGING DISPLAY TECHNOLOGIES CORPORATION	MODEL NO.	VERSION	PAGE
	ET070080DH6	4	30

13.7 NOTICE

- 13.7.1 USE A GROUNDED SOLDERING IRON WHEN SOLDERING CONNECTOR I/O TERMINALS . FOR SOLDERING OR REPAIRING, TAKE PRECAUTION AGAINST THE TEMPERATURE OF THE SOLDERING IRON AND THE SOLDERING TIME TO PREVENT PEELING OFF THE THROUGH-HOLE-PAD .
- 13.7.2 DO NOT DISASSEMBLE . EDT SHALL NOT BE HELD RESPONSIBLE IF THE MODULE IS DISASSEMBLED AND UPON THE REASSEMBLY THE MODULE FAILED .
- 13.7.3 DO NOT CHARGE STATIC ELECTRICITY , AS THE CIRCUIT OF THIS MODULE CONTAINS CMOS LSIS. A WORKMAN'S BODY SHOULD ALWAYS BE STATIC-PROTECTED BY USE OF AN ESD STRAP. WORKING CLOTHES FOR SUCH PERSONNEL SHOULD BE OF STATIC-PROTECTED MATERIAL .
- 13.7.4 ALWAYS GROUND THE ELECTRICALLY-POWERED DRIVER BEFORE USING IT TO INSTALL THE LCD MODULE. WHILE CLEANING THE WORK STATION BY VACUUM CLEANER, DO NOT BRING THE SUCKING MOUTH NEAR THE MODULE ; STATIC ELECTRICITY OF THE ELECTRICALLY-POWERED DRIVER OR THE VACUUM CLEANER MAY DESTROY THE MODULE .
- 13.7.5 DON'T GIVE EXTERNAL SHOCK.
- 13.7.6 DON'T APPLY EXCESSIVE FORCE ON THE SURFACE.
- 13.7.7 LIQUID IN LCD IS HAZARDOUS SUBSTANCE. MUST NOT LICK AND SWALLOW.  
WHEN THE LIQUID IS ATTACH TO YOUR, SKIN, CLOTH ETC. WASH IT OUT THOROUGHLY AND IMMEDIATELY.
- 13.7.8 DON'T OPERATE IT ABOVE THE ABSOLUTE MAXIMUM RATING.
- 13.7.9 STORAGE IN A CLEAN ENVIRONMENT, FREE FROM DUST, ACTIVE GAS, AND SOLVENT.
- 13.7.10 STORE WITHOUT ANY PHYSICAL LOAD.
- 13.7.11 REWIRING: NO MORE THAN 3 TIMES.

02101300-01-02



**Disclaimer:**

**Toradex AG reserves the right to make changes, without notice, to any product, including circuits and/or software described or contained in this datasheet.**

**Toradex AG assumes no responsibility or liability for the use of the described product(s), conveys no license or title under any patent, copyright, or mask work rights to these products, and makes no representations or warranties that these products are free from patent, copyright, or mask work right infringement, unless otherwise specified.**

**Trademark Acknowledgement:**

**Brand and product names are trademarks or registered trademarks of their respective owners.**