



# Technical Data Sheet

## POWER LED

**33-01/B4C-AHKB**

### Features

- . High Flux Output.
- . Low Thermal Resistance.
- . Low Profile.
- . Wide viewing angle 80°
- . ESD-withstand voltage: up to 4KV
- . The product itself will remain within RoHS compliant version.



### Descriptions

This revolutionary package design allows the light designer to reduce the number of LEDs required and provide a more uniform and unique illuminated appearance than with other LED solutions. This is possible through the efficient optical package design and high-current capabilities.

The low profile package can be easily coupled with reflectors or lenses to efficiently distribute light and provide the desired light appearance.

### Applications

- . Automotive Exterior Lighting
- . Electronic Signs and Signals
- . Special Lighting application

### Device Selection Guide

PART NO.	Chip		Lens Color
	Material	Emitted Color	
33-01/B4C-AHKB	InGaN	Blue	Water Clear

# Technical Data Sheet

## POWER LED

**33-01/B4C-AHKB**

### Package Dimensions

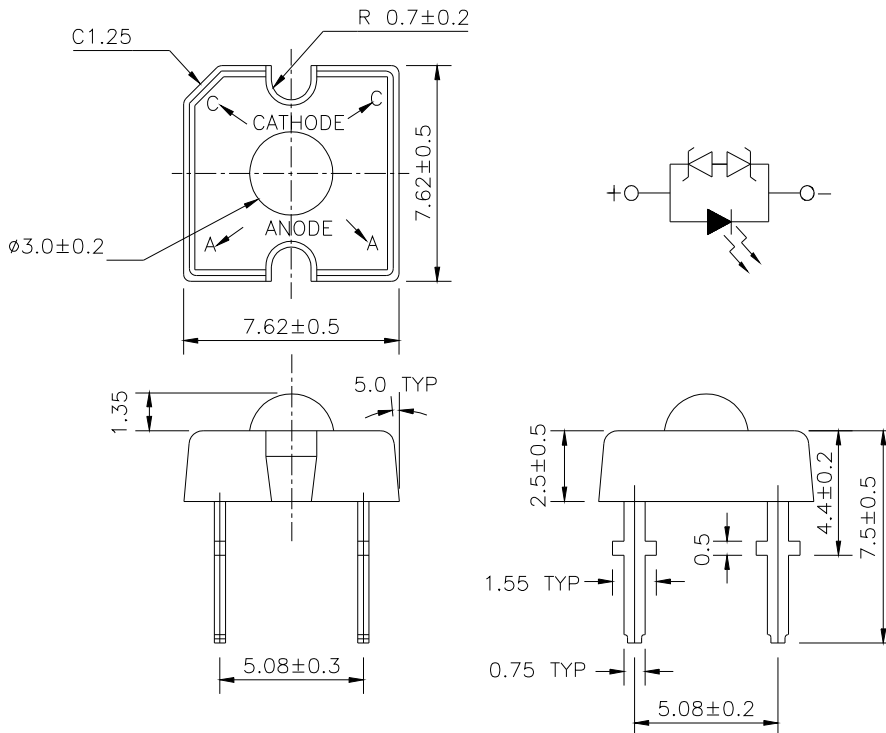

**Notes:** 1.All dimensions are in millimeters

2.An epoxy meniscus may extend about 1.5mm(0.059") down the leads

3.Tolerances unless dimensions  $\pm 0.25\text{mm}$

### Absolute Maximum Ratings ( $T_a=25^\circ\text{C}$ )

Parameter	Symbol	Rating	Units
Continuous Forward Current	$I_F$	30	mA
Peak Forward Current(Duty 1/10 @ 1KHZ)	$I_{FP}$	100	mA
Reverse Voltage	$V_R$	5	V
Operating Temperature	$T_{opr}$	-40 ~ +85	$^\circ\text{C}$
Storage Temperature	$T_{stg}$	-40 ~ +100	$^\circ\text{C}$
Soldering Temperature(T=5 sec)	$T_{sol}$	$260 \pm 5$	$^\circ\text{C}$
Power Dissipation	$P_d$	120	mW
Zener Reverse Current	$I_z$	100	mA
Electrostatic Discharge	ESD	4K	V



# Technical Data Sheet

## POWER LED

**33-01/B4C-AHKB**

### Electro-Optical Characteristics (Ta=25°C)

Parameter	Symbol	Min.	Typ.	Max.	Condition	Unit
Total Flux	$\Phi_v$	715	900	1425	I <sub>F</sub> =30mA	mlm
Viewing Angle	2θ 1/2	----	80	----	I <sub>F</sub> =30mA	deg
Peak Wavelength	λ <sub>p</sub>	----	468	----	I <sub>F</sub> =30mA	Nm
Dominant Wavelength	λ <sub>d</sub>	464	470	472	I <sub>F</sub> =30mA	Nm
Spectrum Radiation Bandwidth	Δλ	----	35	----	I <sub>F</sub> =20mA	nm
Forward Voltage	V <sub>F</sub>	2.8	3.5	4.0	I <sub>F</sub> =30mA	V
Reverse Current	I <sub>R</sub>	----	----	10	V <sub>R</sub> =5V	uA
Zener Reverse Voltage	V <sub>Z</sub>	5.2	----	----	I <sub>Z</sub> =5mA	V

### Rank

33-01/B4C-AHKB

□ □ □  
(1) (2) (3)

(1) V <sub>F</sub> (V)			(2) λ <sub>d</sub>			(3) Φ <sub>v</sub> (mlm)		
Bin.	Min.	Max.	Bin.	Min.	Max.	Bin.	Min.	Max.
0	2.80	3.00	3	464	468	H	715	900
1	3.00	3.20	4	468	472	J	900	1125
2	3.20	3.40		----	----	K	1125	1425
3	3.40	3.60		----	----			
4	3.60	3.80		----	----			
5	3.80	4.00		----	----			

\*Measurement Uncertainty of Forward Voltage : ±0.1V

\*Measurement Uncertainty of Luminous Intensity: ±15%

\*Measurement Uncertainty of Dominant Wavelength ±1.0nm



# Technical Data Sheet

## POWER LED

**33-01/B4C-AHKB**

### Typical Electro-Optical Characteristics Curves

**Relative Intensity vs. Wavelength**

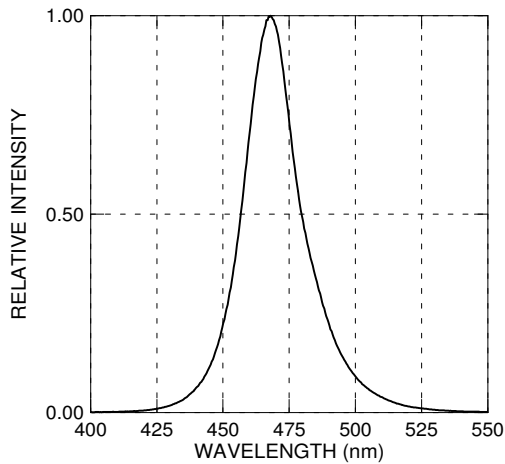

**Forward Current vs. Forward Voltage**

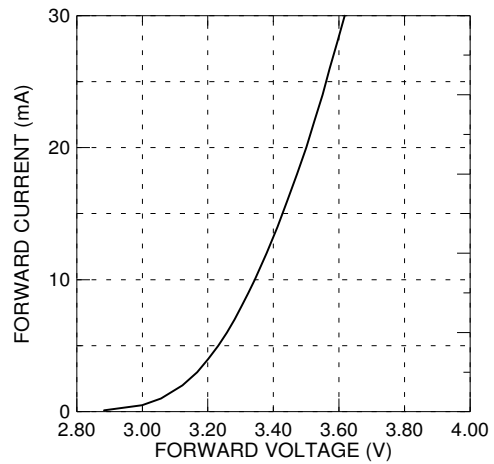

**Relative Intensity vs. Forward Current**

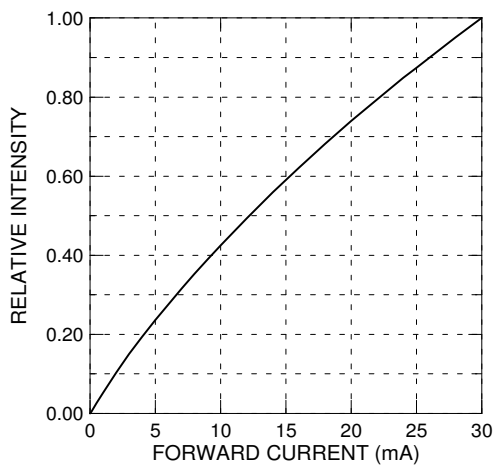

**Forward Current vs. Ambient Temp.**

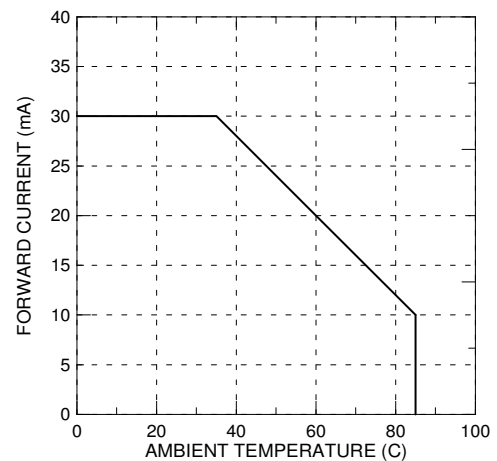

**Relative Intensity vs. Angle Displacement**

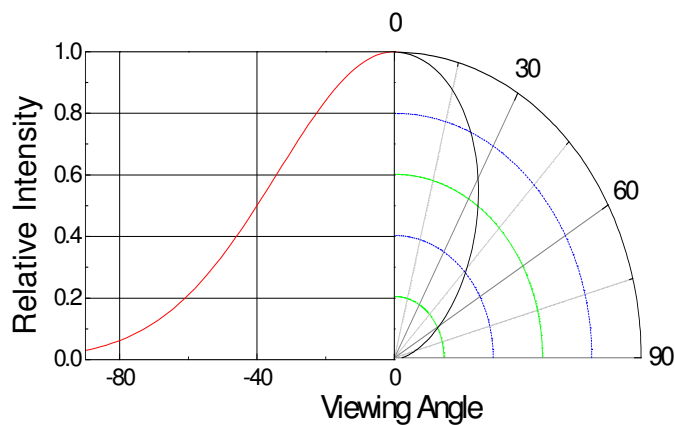





# Technical Data Sheet POWER LED

**33-01/B4C-AHKB**

## Packing Quantity Specification

- (1) 60 pcs/1 tube, 30 tubes/1 small inside box, 12 small inside boxes/1 outside box
- (2) 60 pcs/1 tube, 105 tubes/1 big inside box, 8 big inside boxes/1 outside box

## Label Form Specification

<b>EVERLIGHT</b>	
CPN:	
P/N:	
	RoHS
33-01/B4C-AHKB	
QTY :	CAT:
	HUE:
LOT NO :	REF:
	
MADE IN TAIWAN	

CPN:Customer's Production Number  
P/N :Production Number  
QTY:Packing Quantity  
CAT:Rank of Total Flux and Forward Voltage  
HUE:Rank of Wavelength  
REF:Reference  
LOT No:Lot Number  
MADE IN TAIWAN:Production Place

# Technical Data Sheet

## POWER LED

**33-01/B4C-AHKB**

### Notes

1. Above specification may be changed without notice. EVERLIGHT will reserve authority on material change for above specification.
2. When using this product, please observe the absolute maximum ratings and the instructions for using outlined in these specification sheets. EVERLIGHT assumes no responsibility for any damage resulting from use of the product which does not comply with the absolute maximum ratings and the instructions included in these specification sheets.
3. These specification sheets include materials protected under copyright of EVERLIGHT corporation. Please don't reproduce or cause anyone to reproduce them without EVERLIGHT's consent.
4. Below the zener reference voltage  $V_z$ , all the current flows through LED and as the voltage rises to  $V_z$ , the zener diode "breakdown." If the voltage tries to rise above  $V_z$  current flows through the zener branch to keep the voltage at exactly  $V_z$ .
5. When the LED is connected using serial circuit, if either piece of LED is no light up but current can't flow through causing others to light down. In new design, the LED is parallel with zener diode. if either piece of LED is no light up but current can flow through causing others to light.

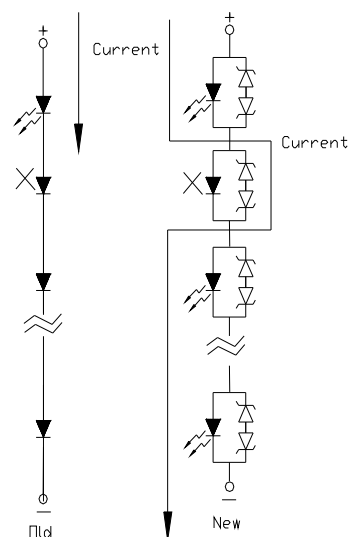



# Technical Data Sheet

## POWER LED

**33-01/B4C-AHKB**

### 6. Soldering Condition

Careful attention should be paid during soldering. When soldering, leave more than 3mm from solder joint to case, and soldering beyond the base of the tie bar is recommended.

Avoiding applying any stress to the lead frame while the LEDs are at high temperature particularly when soldering.

Recommended soldering conditions:

Hand Soldering		DIP Soldering	
Temp. at tip of iron	400°C Max. (30W Max.)	Preheat temp.	100°C Max. (60 sec Max.)
Soldering time	3 sec Max.	Bath temp.	265 Max.
Distance	3mm Min.(From solder joint to case)	Bath time.	5 sec Max.
		Distance	3mm Min.

**EVERLIGHT ELECTRONICS CO., LTD.**  
Office: No 25, Lane 76, Sec 3, Chung Yang Rd,  
Tucheng, Taipei 236, Taiwan, R.O.C

Tel: 886-2-2267-2000, 2267-9936  
Fax: 886-2267-6244, 2267-6189, 2267-6306  
<http://www.everlight.com>