

### Features:

- High speed 10Mbit/s
- 10kV/μs minimum common mode transient immunity at  $V_{CM} = 1KV$  (EL0611)
- Guaranteed performance from -40 to 85°C
- Wide operating temperature range of -40°C to 100°C
- Logic gate output
- High isolation voltage between input and output ( $V_{iso} = 3750 V_{rms}$ )
- Pb free and RoHS and Halogen free compliant.
- cUL approved (No. E214129)
- VDE approved (No. 40028116)
- SEMKO approved
- NEMKO approved
- DEMKO approved
- FIMKO approved

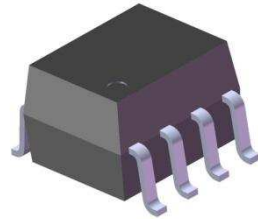

### Description

The EL0600, EL0601 and EL0611 devices each consists of an infrared emitting diode optically coupled to a high speed integrated photo detector logic gate with a strobable output.

The devices are packaged in an 8-pin small outline package which conforms to the standard SO8 footprint.

Schematic

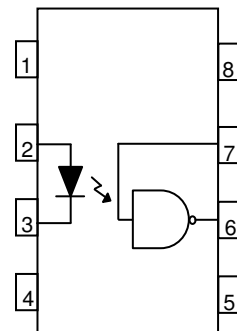

A 0.1μF bypass capacitor must be connected between pins 8 and 5<sup>\*3</sup>

### Applications

- Ground loop elimination
- LSTTL to TTL, LSTTL or 5 volt CMOS
- Line receiver, data transmission
- Data multiplexing
- Switching power supplies
- Pulse transformer replacement
- Computer peripheral interface

### Pin Configuration

- 1, No Connection
- 2, Anode
- 3, Cathode
- 4, No Connection
- 5, Gnd
- 6, Vout
- 7,  $V_E$
- 8,  $V_{CC}$

### Truth Table (Positive Logic)

Input	Enable	Output
H	H	L
L	H	H
H	L	H
L	L	H
H	NC	L
L	NC	H

### Absolute Maximum Ratings ( $T_a=25^\circ\text{C}$ )

Parameter		Symbol	Rating	Unit
Input	Forward current	$I_F$	20	mA
	Enable input voltage Not exceed $V_{CC}$ by more than 500mV	$V_E$	5.5	V
	Reverse voltage	$V_R$	5	V
	Power dissipation	$P_D$	40	mW
Output	Power dissipation	$P_C$	85	mW
	Enable input current	$I_E$	5	mA
	Output current	$I_O$	50	mA
	Output voltage	$V_O$	7.0	V
	Supply voltage	$V_{CC}$	7.0	V
Output Power Dissipation		$P_O$	100	mW
Isolation voltage <sup>*1</sup>		$V_{ISO}$	3750	V rms
Operating temperature		$T_{OPR}$	-40 ~ +100	$^\circ\text{C}$
Storage temperature		$T_{STG}$	-55 ~ +125	$^\circ\text{C}$
Soldering temperature <sup>*2</sup>		$T_{SOL}$	260	$^\circ\text{C}$

#### Notes

\*1 AC for 1 minute, R.H.= 40 ~ 60% R.H. In this test, pins 1 , 2 , 3 & 4 are shorted together, and pins 5 , 6 , 7 & 8 are shorted together.

\*2 For 10 seconds.

### Electrical Characteristics ( $T_a=-40$ to $85^\circ\text{C}$ unless specified otherwise)

#### Input

Parameter	Symbol	Min.	Typ.*	Max.	Unit	Condition
Forward voltage	$V_F$	-	1.4	1.8	V	$I_F = 10\text{mA}$
Reverse voltage	$V_R$	5.0	-	-	V	$I_R = 10\mu\text{A}$
Temperature coefficient of forward voltage	$\Delta V_F/\Delta T_A$	-	-1.8	-	mV/ $^\circ\text{C}$	$I_F = 10\text{mA}$
Input capacitance	$C_{IN}$	-	60	-	pF	$V_F = 0, f = 1\text{MHz}$

#### Output

Parameter	Symbol	Min.	Typ.*	Max.	Unit	Condition
High level supply current	$I_{CCH}$	-	-	10	mA	$I_F = 10\text{mA}, V_E = 0.5\text{V}, V_{CC} = 5.5\text{V}$
Low level supply current	$I_{CCL}$	-	-	13	mA	$I_F = 0\text{mA}, V_E = 0.5\text{V}, V_{CC} = 5.5\text{V}$
High level enable current	$I_{EH}$	-	-	-1.6	mA	$V_E = 2.0\text{V}, V_{CC} = 5.5\text{V}$
Low level enable current	$I_{EL}$	-	-	-1.6	mA	$V_E = 0.5\text{V}, V_{CC} = 5.5\text{V}$
High level enable voltage	$V_{EH}$	2.0	-	-	V	$I_F = 10\text{mA}, V_{CC} = 5.5\text{V}$
Low level enable voltage <sup>*4</sup>	$V_{EL}$	-	-	0.8	V	$I_F = 10\text{mA}, V_{CC} = 5.5\text{V}$

### Transfer Characteristics ( $T_a=-40$ to $85^\circ\text{C}$ unless specified otherwise)

Parameter	Symbol	Min.	Typ.*	Max.	Unit	Condition
HIGH Level Output Current	$I_{OH}$	-	-	100	$\mu\text{A}$	$V_{CC} = 5.5\text{V}, V_O = 5.5\text{V}, I_F = 250\mu\text{A}, V_E = 2.0\text{V}$
LOW Level Output Current	$V_{OL}$	-	-	0.6	V	$V_{CC} = 5.5\text{V}, I_F = 5\text{mA}, V_E = 2.0\text{V}, I_{CL} = 13\text{mA}$
Input Threshold Current	$I_{FT}$	-	-	5	mA	$V_{CC} = 5.5\text{V}, V_O = 0.6\text{V}, V_E = 2.0\text{V}, I_{OL} = 13\text{mA}$

#### Switching Characteristics (T<sub>a</sub>=-40 to 85 °C, V<sub>CC</sub>=5V, I<sub>F</sub>=7.5mA unless specified otherwise)

Parameter	Symbol	Min.	Typ.*	Max.	Unit	Condition
Propagation delay time to output High level <sup>*5</sup> (Fig.12)	T <sub>PHL</sub>	-	35	75	ns	C <sub>L</sub> = 15pF, R <sub>L</sub> =350Ω, TA=25°C
Propagation delay time to output Low level <sup>*6</sup> (Fig.12)	T <sub>PLH</sub>	-	45	75	ns	C <sub>L</sub> = 15pF, R <sub>L</sub> =350Ω, TA=25°C
Pulse width distortion	T <sub>phl</sub> – T <sub>plh</sub>	-	10	35	ns	C <sub>L</sub> = 15pF, R <sub>L</sub> =350Ω
Output rise time (Fig.12) <sup>*7</sup>	tr	-	30	40	ns	C <sub>L</sub> = 15pF, R <sub>L</sub> =350Ω
Output fall time (Fig.12) <sup>*8</sup>	tf	-	10	20	ns	C <sub>L</sub> = 15pF, R <sub>L</sub> =350Ω
Enable Propagation Delay Time to Output High Level (Fig.13) <sup>*9</sup>	t <sub>ELH</sub>	-	30	40	ns	I <sub>F</sub> = 7.5mA, V <sub>EH</sub> =3.5V, C <sub>L</sub> = 15pF, R <sub>L</sub> =350Ω
Enable Propagation Delay Time to Output Low Level (Fig.13) <sup>*10</sup>	t <sub>EHL</sub>	-	20	30	ns	I <sub>F</sub> = 7.5mA, V <sub>EH</sub> =3.5V, C <sub>L</sub> = 15pF, R <sub>L</sub> =350Ω
Common Mode Transient Immunity at Logic High <sup>*11</sup>	EL0600	-	-	-	V/μS	I <sub>F</sub> = 7.5mA, V <sub>OH</sub> =2.0V, R <sub>L</sub> =350Ω, TA=25°C V <sub>CM</sub> =10Vp-p (Fig.14)
	EL0601	5,000	-	-		I <sub>F</sub> = 7.5mA, V <sub>OH</sub> =2.0V, R <sub>L</sub> =350Ω, TA=25°C V <sub>CM</sub> =50Vp-p (Fig.14)
	EL0611	10,000	-	-		I <sub>F</sub> = 7.5mA, V <sub>OH</sub> =2.0V, R <sub>L</sub> =350Ω, TA=25°C V <sub>CM</sub> =400Vp-p (Fig.14)
	EL0611	15,000	-	-		I <sub>F</sub> = 7.5mA, V <sub>OH</sub> =2.0V, R <sub>L</sub> =350Ω, TA=25°C V <sub>CM</sub> =400Vp-p (Fig.15)
Common Mode Transient Immunity at Logic Low <sup>*12</sup>	EL0600	-	-	-	V/μS	I <sub>F</sub> = 0mA, V <sub>OL</sub> =0.8V, R <sub>L</sub> =350Ω, TA=25°C V <sub>CM</sub> =10Vp-p (Fig.14)
	EL0601	5,000	-	-		I <sub>F</sub> = 0mA, V <sub>OL</sub> =0.8V, R <sub>L</sub> =350Ω, TA=25°C V <sub>CM</sub> =50Vp-p (Fig.14)
	EL0611	10,000	-	-		I <sub>F</sub> = 0mA, V <sub>OL</sub> =0.8V, R <sub>L</sub> =350Ω, TA=25°C V <sub>CM</sub> =400Vp-p (Fig.14)
	EL0611	15,000	-	-		I <sub>F</sub> = 7.5mA, V <sub>OL</sub> =0.8V, R <sub>L</sub> =350Ω, TA=25°C V <sub>CM</sub> =400Vp-p (Fig.15)

### Typical Performance Curves

Figure 1. Forward Current vs Forward Voltage

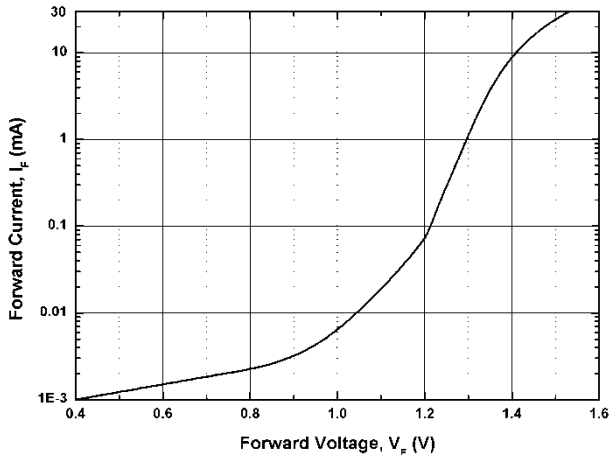

Figure 2. Low Level Output Voltage vs Ambient Temperature

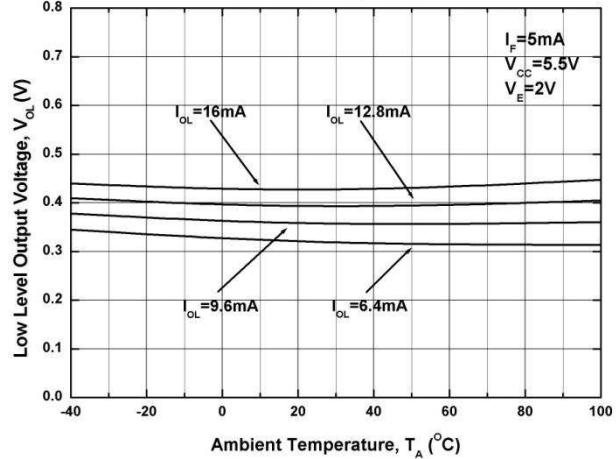

Figure 3. Low Level Output Current vs Ambient Temperature

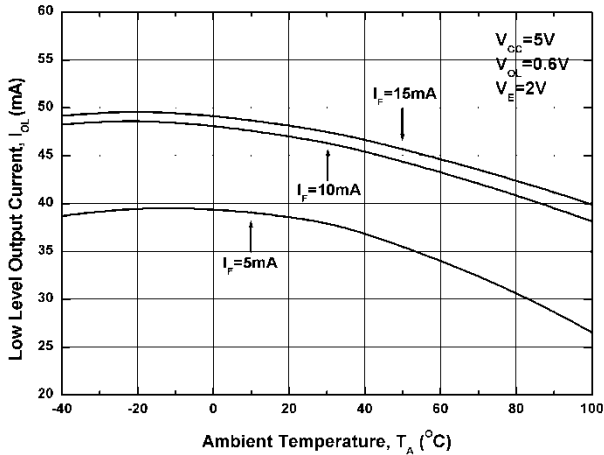

Figure 4. Input Threshold Current vs Ambient Temperature

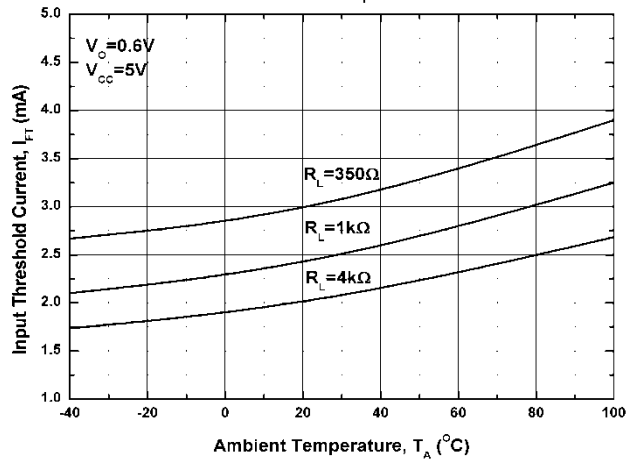

Figure 5. Input Current vs Output Voltage

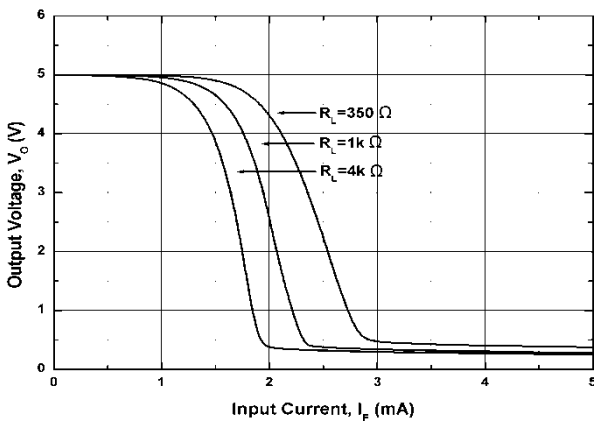

Figure 6. High Level Output Current vs Ambient Temperature

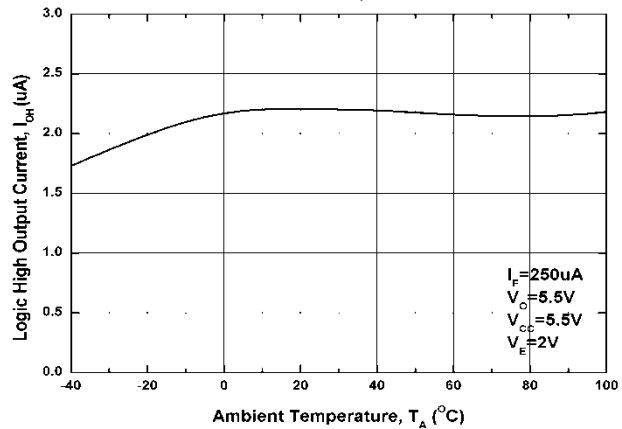

Figure 7. Propagation Delay vs. Forward Current

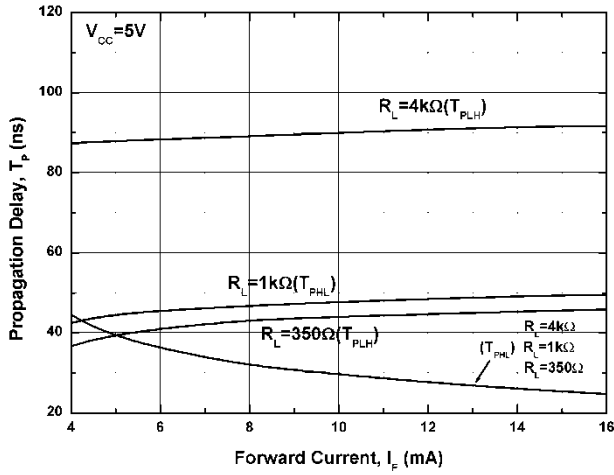

Figure 8. Propagation Delay vs. Temperature

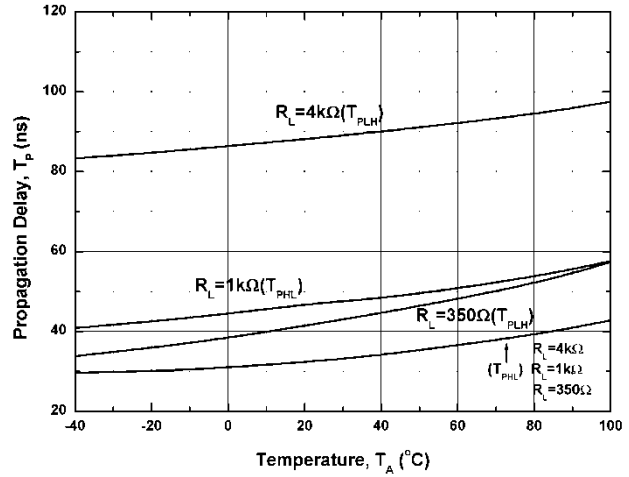

Figure 9. Pulse Width Distortion vs. Temperature

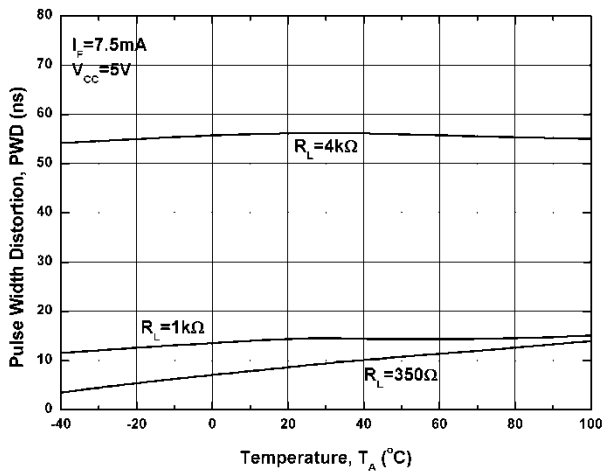

Figure 10. Rise and Fall Time vs. Temperature

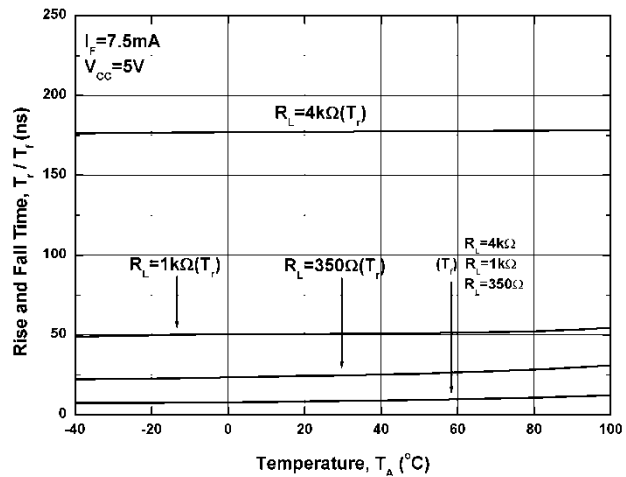
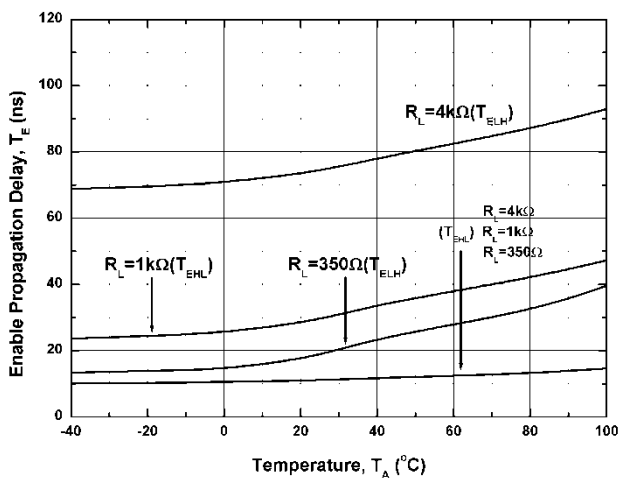
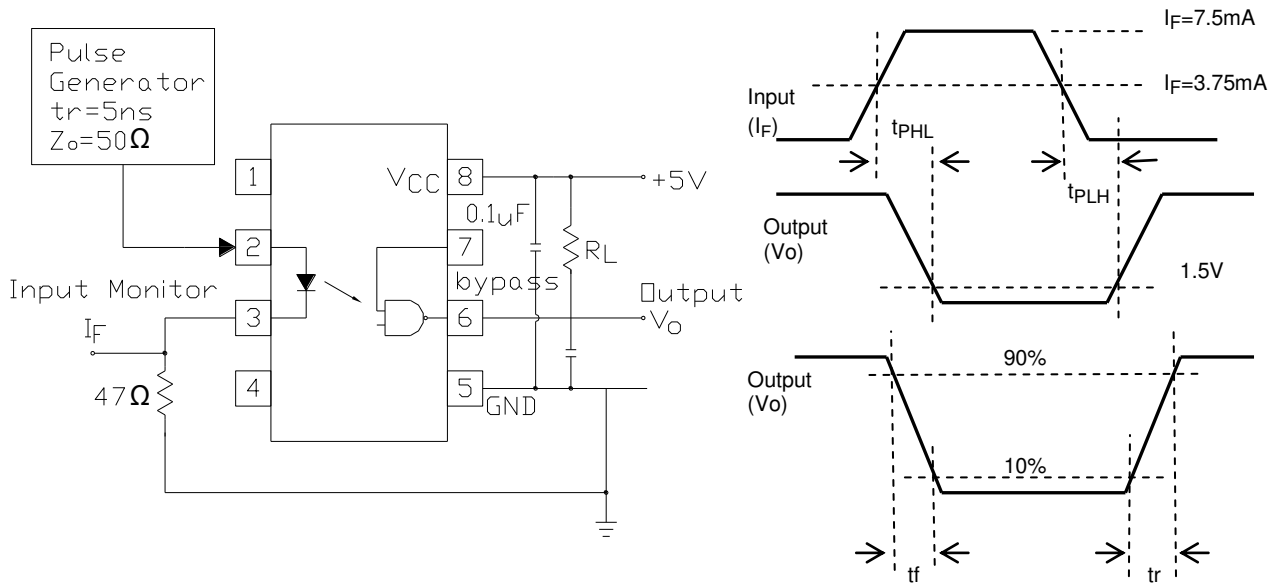
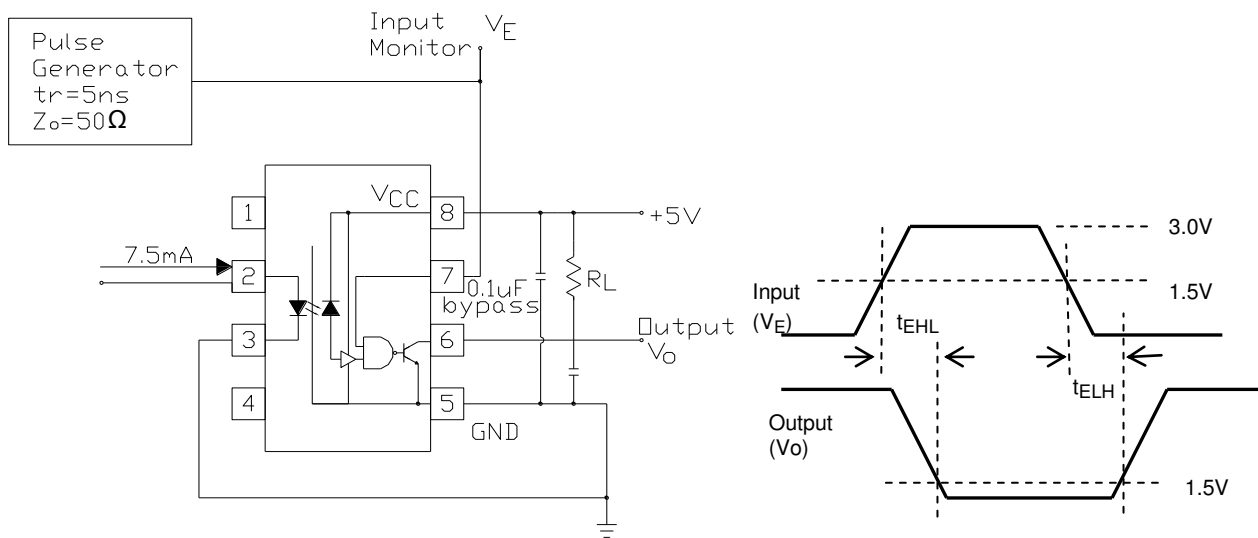

Figure 11. Enable Propagation Delay vs. Temperature

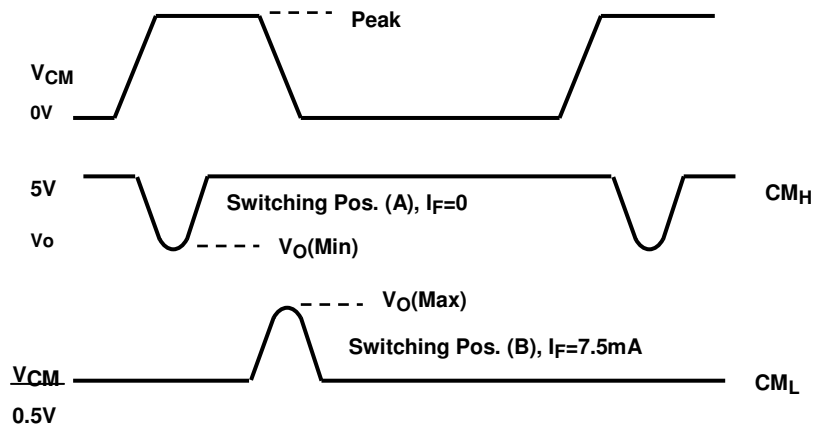
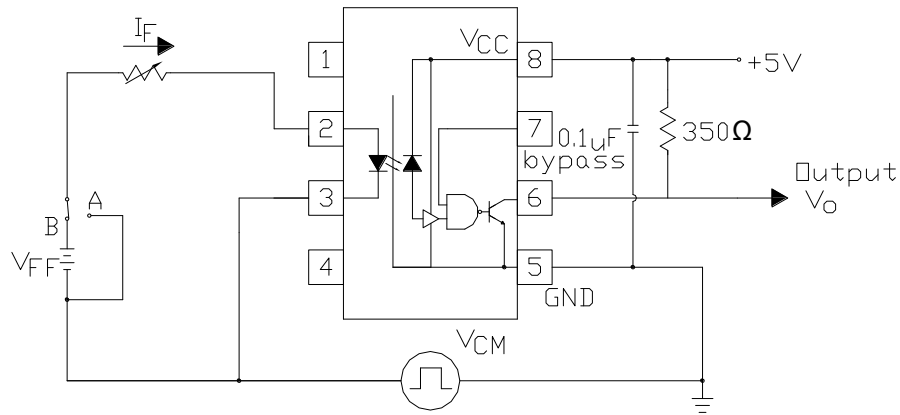



**Fig. 12 Test circuit and waveforms for  $t_{PHL}$ ,  $t_{PLH}$ ,  $t_r$ , and  $t_f$**



**Fig. 13 Test circuit and waveform for  $t_{EHL}$  and  $t_{ELH}$**



**Fig. 14 Test circuit Common mode Transient Immunity**

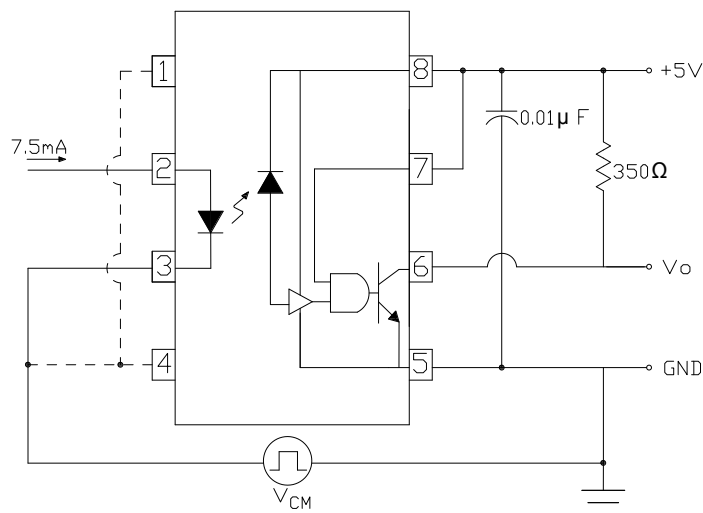

**Fig. 15 Recommended drive circuit for EL0611 families for high-CMR**

### Notes:

- \*3 The VCC supply must be bypassed by a 0.1 $\mu$ F capacitor or larger. This can be either a ceramic or solid tantalum capacitor with good high frequency characteristic and should be connected as close as possible to the package VCC and GND pins
- \*4. Enable Input – No pull up resistor required as the device has an internal pull up resistor.
- \*5. tPLH – Propagation delay is measured from the 3.75mA level on the HIGH to LOW transition of the input current pulse to the 1.5 V level on the LOW to HIGH transition of the output voltage pulse.
- \*6. tPHL – Propagation delay is measured from the 3.75mA level on the LOW to HIGH transition of the input current pulse to the 1.5 V level on the HIGH to LOW transition of the output voltage pulse.
- \*7. tr – Rise time is measured from the 90% to the 10% levels on the LOW to HIGH transition of the output pulse.
- \*8. tf – Fall time is measured from the 10% to the 90% levels on the HIGH to LOW transition of the output pulse.
- \*9. tELH – Enable input propagation delay is measured from the 1.5V level on the HIGH to LOW transition of the input voltage pulse to the 1.5V level on the LOW to HIGH transition of the output voltage pulse.
- \*10. tEHL – Enable input propagation delay is measured from the 1.5V level on the LOW to HIGH transition of the input voltage pulse to the 1.5V level on the HIGH to LOW transition of the output voltage pulse.
- \*11 CMH– The maximum tolerable rate of rise of the common mode voltage to ensure the output will remain in the HIGH state (i.e., VOUT > 2.0V).
- \*12 CML– The maximum tolerable rate of rise of the common mode voltage to ensure the output will remain in the LOW output state (i.e., VOUT < 0.8V).

### Order Information

#### Part Number

## EL06XX(Z)-V

#### Note

- X = Part no. ( X = 00, 01 or 11)
- Z = Tape and reel option (TA, TB or none).
- V = VDE (optional)

Option	Description	Packing quantity
None	Standard	100 units per tube
-V	Standard + VDE	100 units per tube
(TA)	TA tape & reel option	2000 units per reel
(TB)	TB tape & reel option	2000 units per reel
(TA)-V	TA tape & reel option + VDE	2000 units per reel
(TB)-V	TB tape & reel option + VDE	2000 units per reel

### Package Drawing

(Dimensions in mm)

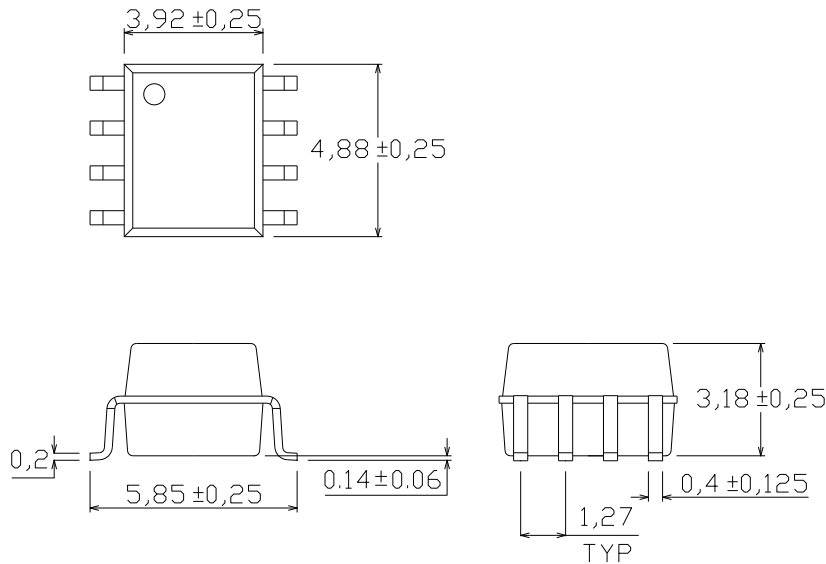

### Recommended pad layout for surface mount leadform

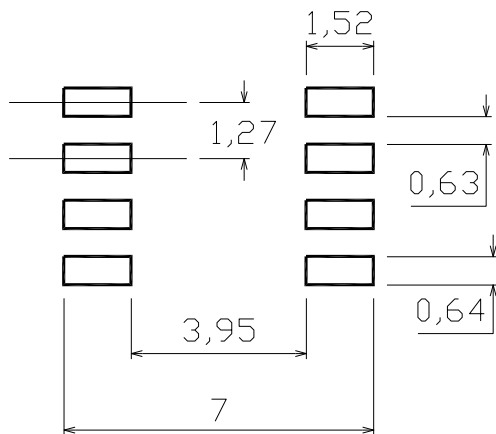

### Device Marking

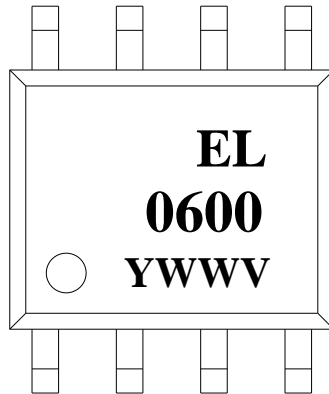

### Notes

- 0600 denotes Device Number
- Y denotes 1 digit Year code
- WW denotes 2 digit Week code
- V denotes VDE (optional)

### Tape & Reel Packing Specifications

#### Option TA

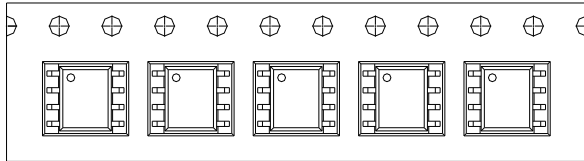

Direction of feed from reel

#### Option TB

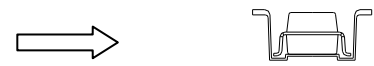
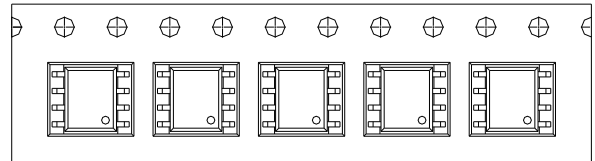

Direction of feed from reel

### Tape dimensions

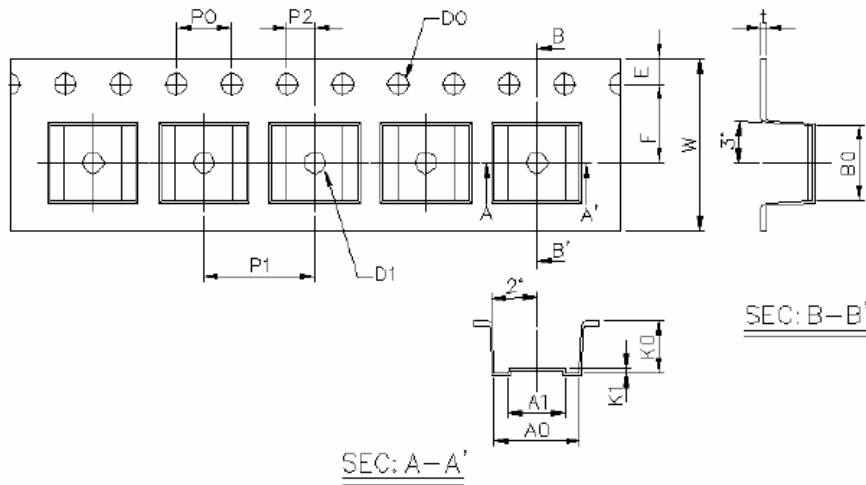

Dimension No.	<b>A0</b>	<b>A1</b>	<b>B0</b>	<b>D0</b>	<b>D1</b>	<b>E</b>	<b>F</b>
Dimension(mm)	6.2±0.1	4.1±0.1	5.28±0.1	1.5±0.1	1.5±0.3	1.75±0.1	5.5±0.1
Dimension No.	<b>Po</b>	<b>P1</b>	<b>P2</b>	<b>t</b>	<b>W</b>	<b>K0</b>	<b>K1</b>
Dimension(mm)	4.0±0.1	8.0±0.1	2.0±0.1	0.4±0.1	12.0+0.3/ -0.1	3.7±0.1	0.3±0.1

### Solder Reflow Temperature Profile

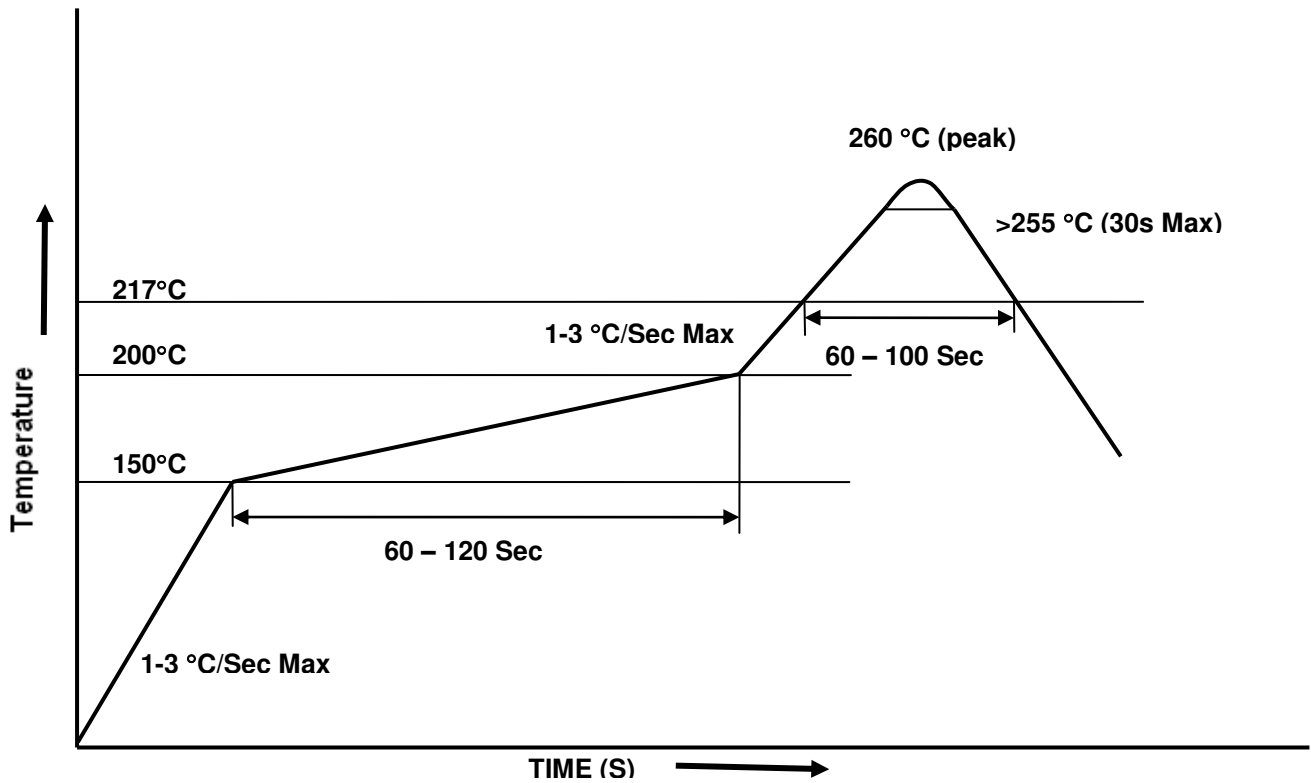

### DISCLAIMER

1. Above specification may be changed without notice. EVERLIGHT will reserve authority on material change for above specification.
2. When using this product, please observe the absolute maximum ratings and the instructions for using outlined in these specification sheets. EVERLIGHT assumes no responsibility for any damage resulting from use of the product which does not comply with the absolute maximum ratings and the instructions included in these specification sheets.
3. These specification sheets include materials protected under copyright of EVERLIGHT corporation. Please don't reproduce or cause anyone to reproduce them without EVERLIGHT's consent.