



LIGHTING FOREVER

## Surface - Mount I<sup>2</sup>C Digital Ambient Light Sensor

ALS-PDI C17-79NB/ TR8

---

### Features

- Close to the human eye's response
- 15 bit effective resolution
- 50Hz/60Hz rejection
- Low sensitivity variation across various light sources
- Operating temperature performance, -40°C to 85°C
- Wide supply voltage range, 2.7V to 5.5V
- Low power consumption, less than 2mW while operating
- Shut-down mode, current consumption less than 0.1uA
- I<sup>2</sup>C serial port communication: (1) Standard 100kHz, (2).Fast 400kHz
- High dynamic sensing range and from 0 to 220000 Lux
- Size : 2.0mm(L)\*2mm(W)\*0.6mm(H)
- RoHS compliant and Pb Free package

### Description

The ALS-PDIC17-79NB/TR8 is a digital-output light sensor with a two-wire, I<sup>2</sup>C serial interface that is compatible with SMBus when working at 100kHz serial clock frequency. It combines a photodiode and an analog-to-digital converter (ADC) on a single CMOS integrated circuit to provide light measurements over an effective 15-bit dynamic range. Two operation modes are provided with one for constantly refreshing ADC and the other for one time integration. When working in "one time integration" mode, no external resistor is required. The integrating conversion technique used by ALS-PDIC17-79NB/TR8 effectively eliminates the effect of flicker from AC-powered lamps, increasing the stability of the measurement. ALS-PDIC17-79NB/TR8 is very close to human-eye vision, having very low response to non-visible light, such as infrared and ultra-violet light.

### Applications

- Detection of ambient light for controlling the backlighting of TFT LCD display
- Automatic residential and commercial lighting management
- Automatic contrast enhancement for electronic signboard
- Ambient light monitoring device for daylight and artificial light



LIGHTING FOREVER

# Surface - Mount I<sup>2</sup>C Digital Ambient Light Sensor

## ALS-PDI C17-79NB/ TR8

### Package Dimensions

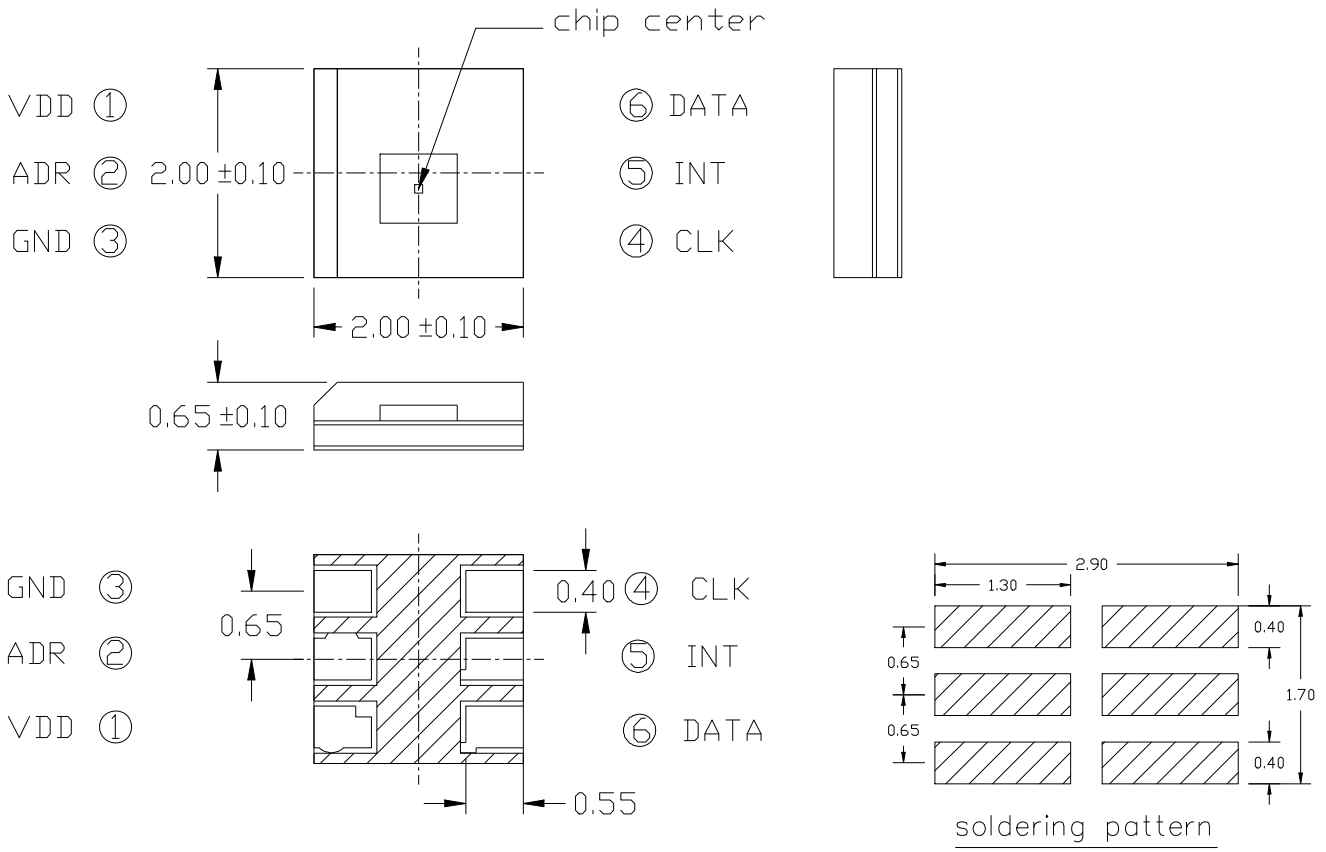

- Note: 1. All Units are mm.**  
**2. Unspecified tolerance is ±0.10mm**

Absolute Maximum Ratings (Ta=25°C)

Parameter	Symbol	Min.	Max.	Units
Storage temperature	T <sub>STG</sub>	-40	100	°C
Operating temperature	T <sub>OPR</sub>	-40	85	°C
Supply voltage	V <sub>DD</sub>	-0.3	6.0	V
Digital output voltage	V <sub>O</sub>	-0.3	6.0	V
Digital output current	I <sub>O</sub>	-10	+10	mA
ESD tolerance, human body model	-	2	-	KV

Block Diagram & Pad Descriptions

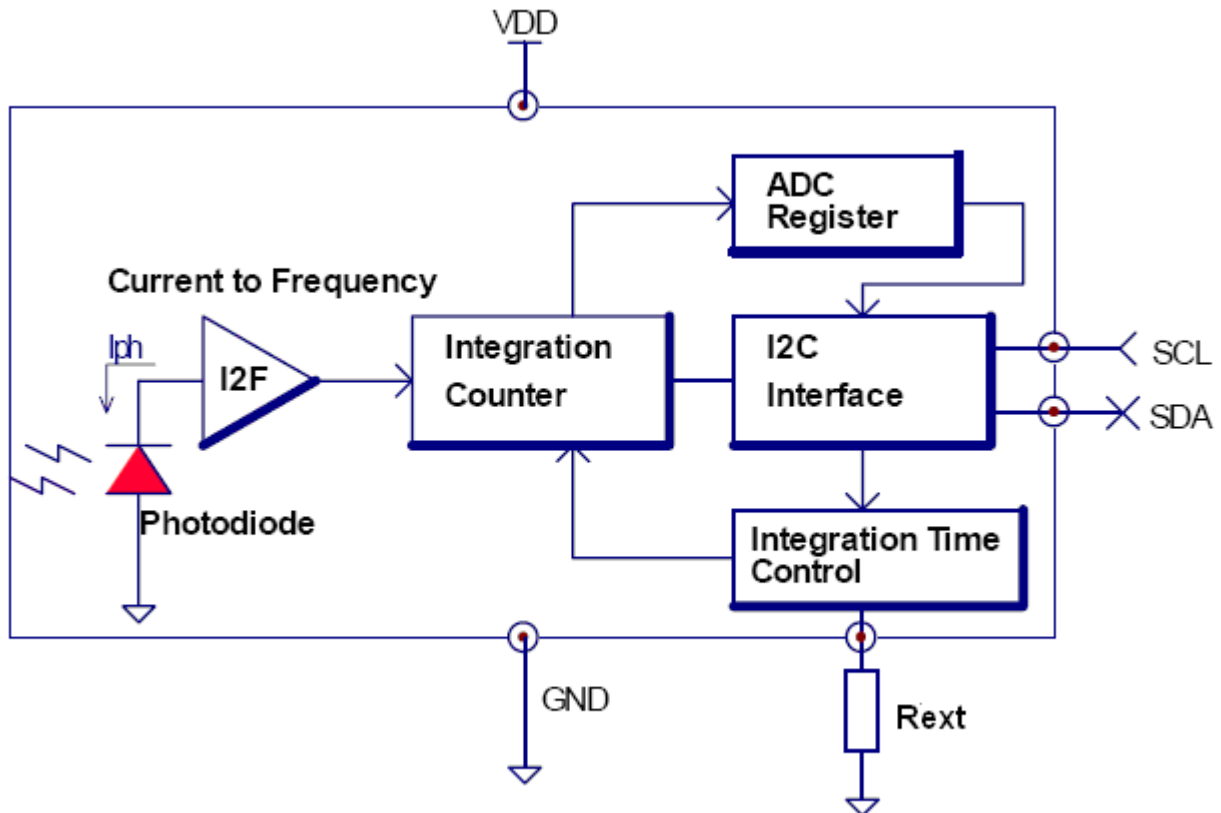

Figure 1. ALS-PDI C17-79NB/TR8 Functional Block Diagram



LIGHTING FOREVER

# Surface - Mount I<sup>2</sup>C Digital Ambient Light Sensor

ALS-PDI C17-79NB/ TR8

## Electrical and Optical Characteristics (Ta=25°C , V<sub>DD</sub>=3.3V)

Parameter	Symbol	Test Conditions	Min.	Typ.	Max.	Units
Supply current	I <sub>DD</sub>	Active mode	-	0.4	0.5	mA
	I <sub>DDQ</sub>	Power-down mode	-	-	0.1	uA
I <sup>2</sup> C output low voltage	V <sub>OL</sub>	I <sub>o</sub> = 4mA	-	-	0.4	V
Detection limit		Full scale	-	-	32,767	count
		T <sub>int</sub> = 100mS	-	-	110,000	lux
Peak sensitivity wavelength	λ <sub>p</sub>	-	-	550	-	nm
Response in dark environment	R <sub>dak</sub>	E <sub>v</sub> = 0 lux, T <sub>int</sub> = 100 mS	-	-	1	count
Response to incandescent lamp	R <sub>icd</sub>	E <sub>v</sub> = 100 lux T <sub>int</sub> = 100 mS	23	32	-	counts
Response to fluorescent lamp	R <sub>frst</sub>	E <sub>v</sub> = 100 lux T <sub>int</sub> = 100 mS	20	30	-	count

## DC Characteristics of I<sup>2</sup>C Signals in Standard and Fast Mode

Parameter	Symbol	Standard Mode		Fast Mode		Unit
		Min.	Max.	Min.	max.	
Power supply voltage (recommend)	V <sub>DD</sub>	2.7	5.5	2.7	5.5	V
Low level input voltage	V <sub>IL</sub>	-0.5	1.0	-0.5	1.0	V
High level input voltage	V <sub>IH</sub>	2.0		2.0		V
Hysteresis of Schmit trigger inputs (V <sub>DD</sub> > 2V)	V <sub>hys</sub>	0.05V <sub>DD</sub>	-	0.05V <sub>DD</sub>	-	V
Low level output voltage (open drain) at 3mA sink current (V <sub>DD</sub> > 2V)	V <sub>OL1</sub>	0	0.4	0	0.4	V
Output fall time from V <sub>IHMIN</sub> to V <sub>ILMAX</sub> with a bus capacitance from 10pF to 400pF	t <sub>of</sub>	-	250 <sup>[2]</sup>	20+0.1Cb <sup>[1]</sup>	250 <sup>[2]</sup>	nS
Input current of each IO pins with an input voltage between 0.1V <sub>DD</sub> and 0.9V <sub>DD</sub>	I <sub>i</sub>	-10	10	-10	10	uA
Capacitance for each IO pin	C <sub>i</sub>	-	10	-	10	pF

Notes:

1. C<sub>b</sub> = capacitance of one bus line in pF
2. The maximum t<sub>f</sub> for the I<sup>2</sup>C data and clock bus lines quoted in the AC table is longer than the specified maximum t<sub>of</sub> for the output stages (250nS). This allows series protection resistors (R<sub>s</sub>) to be connected between I<sup>2</sup>C data / clock pins and the I<sup>2</sup>C data / clock bus lines without exceeding the maximum specified t<sub>f</sub>.

AC Characteristics of I2C Signals in Standard and Fast Mode

Parameter	Symbol	Standard Mode		Fast Mode		Unit
		Min.	Max.	Min.	max.	
I <sup>2</sup> C clock frequency	fSCL	0	100	0	400	KHz
Hold time (repeated) START condition. After this period, the first clock pulse is generated.	tHD;STA	4.0		0.6	-	uS
Low period of I <sup>2</sup> C clock	tLOW	4.7		1.3		uS
High period of I <sup>2</sup> C clock	tHIGH	4.0		0.6		uS
Set-up time for a repeated START condition	tSU;STA	4.7		0.6		uS
Data hold time for I <sup>2</sup> C-bus devices	tHD;DAT	0	3.45	0	0.9	uS
Data set-up time	tSU;DAT	250	-	100	-	nS
Rise time of both I <sup>2</sup> C data and clock signals	tr	-	1000	5	300	nS
Fall time of both I <sup>2</sup> C data and clock signals	tf	-	300	0.1	300	nS
Set-up time for STOP condition	tSU;STO	4.0	-	0.6	-	uS
Bus free time between STOP and START condition	tBUF	4.7	-	1.3	-	uS
Capacitive load for each bus line	Cb	-	400	-	400	pF
Noise margin at the low level for each connected device (including hysteresis)	VnL	0.1VDD	-	0.1VDD	-	V
Noise margin at the high level for each connected device (including hysteresis)	VnH	0.2VDD	-	0.2VDD	-	V

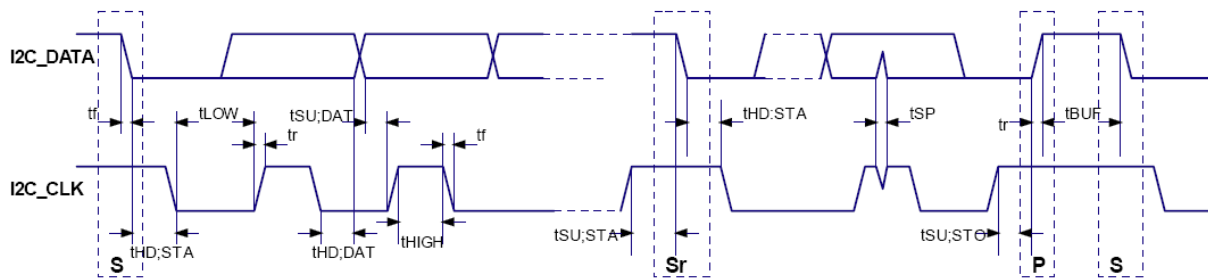

S: Start Sr: Repeated Start P: Stop

Figure 2. I<sup>2</sup>C Timing Diagram



LIGHTING FOREVER

# Surface - Mount I<sup>2</sup>C Digital Ambient Light Sensor

ALS-PDI C17-79NB/ TR8

## Typical Electrical and Optical Characteristics Curves

Fig.3 Output code vs. Illuminance

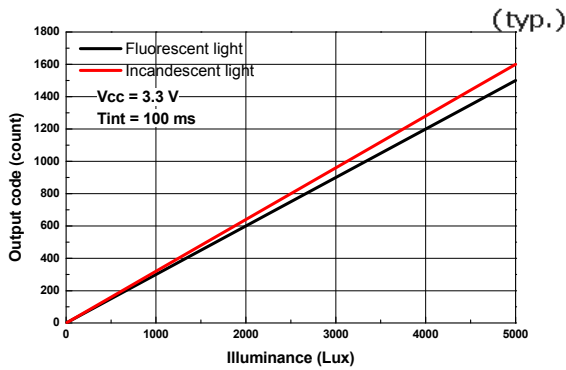

Fig.4 Output code vs. Supply voltage

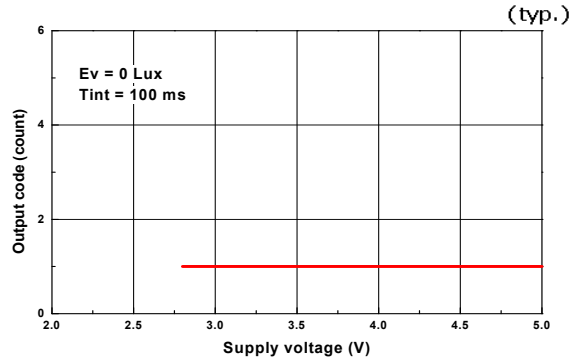

Fig.5 Output code vs. Supply voltage

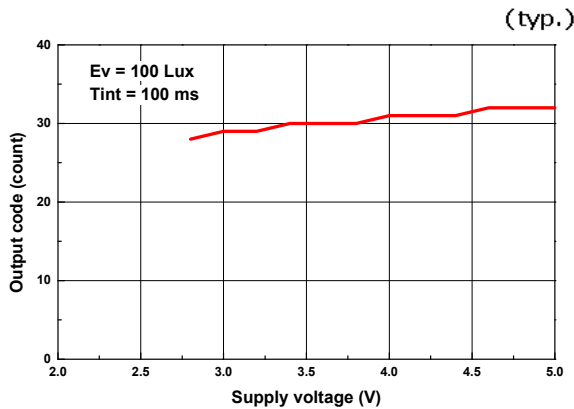

Fig.6 Supply current vs. Supply voltage

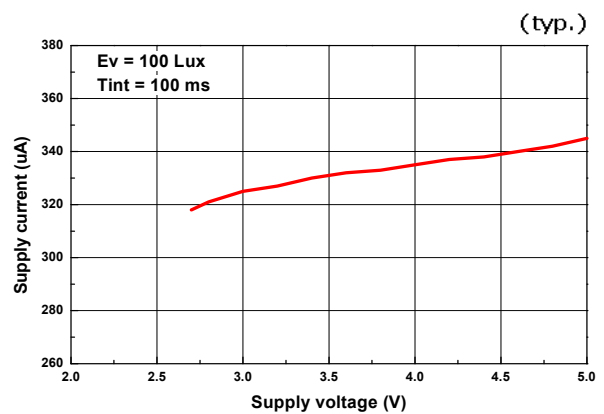

Fig.7 Supply current vs. Temperature

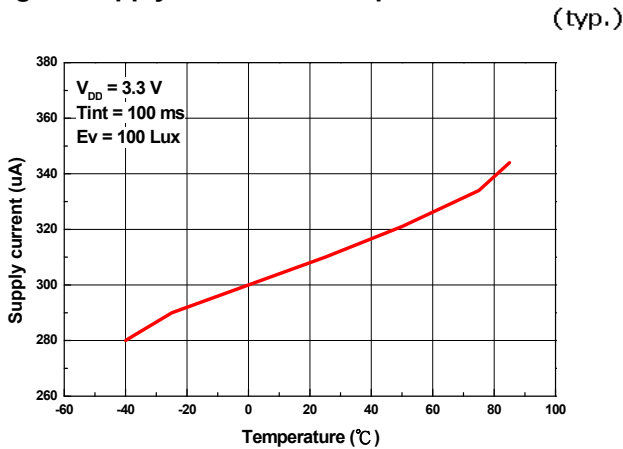
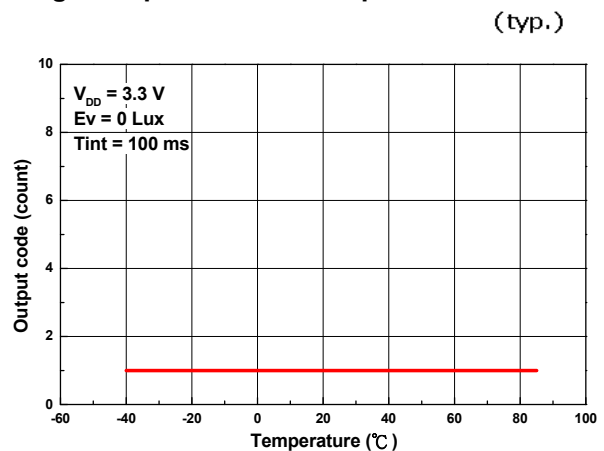

Fig.8 Output code vs. Temperature





LIGHTING FOREVER

# Surface - Mount I<sup>2</sup>C Digital Ambient Light Sensor

## ALS-PDI C17-79NB/ TR8

Fig.9 Output code vs. Temperature (typ.)

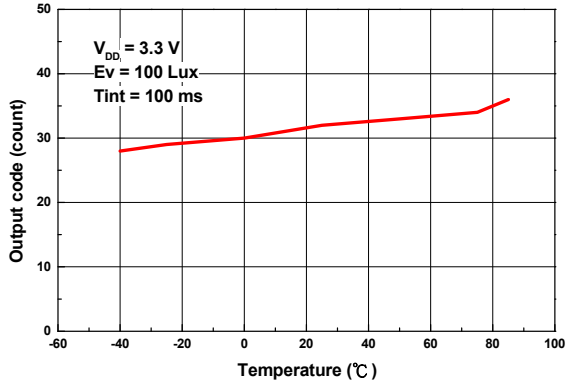
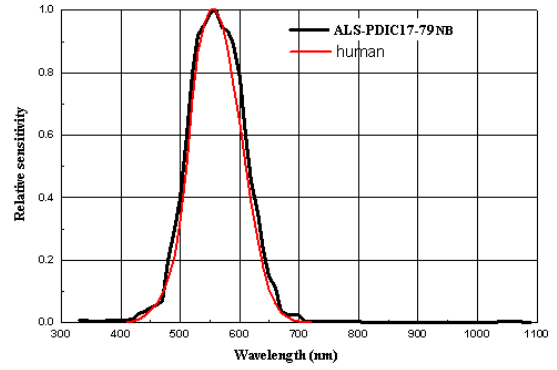

Fig.10 Spectral response (typ.)





LIGHTING FOREVER

# Surface - Mount I<sup>2</sup>C Digital Ambient Light Sensor

ALS-PDIC17-79NB/ TR8

## Communication Protocol

ALS-PDIC17-79NB contains an 8-bit command register that can be written and read via the I<sup>2</sup>C bus. The command register controls the overall operation of the device. There is a two-byte word read-only register that contains the latest converted value of A/D converter. The I<sup>2</sup>C slave address is hardwired internally as 0111001 (0x39, MSB to LSB, A6 to A0). All the Send Byte protocol, the Receive Byte protocol and Receive Word protocol are implemented in ALS-PDIC17-79NB.

The Send Byte protocol allows single bytes of data to be written to the device (see Figure 11-a). The written byte is called the COMMAND byte. The Receive Byte protocol allows one-byte data to be read from the device (see Figure 11-b). Two-byte data can be read by following the Receive Word Protocol shown in Figure 11-c. In Figure 11, the clear area represents data sent by the host (master) and the shaded area represents data returned by the ambient light sensor (slave device).

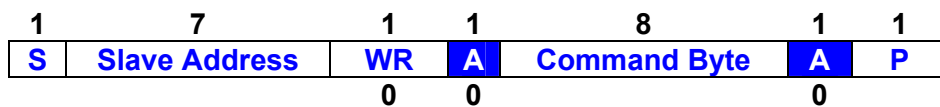

(a) send byte protocol

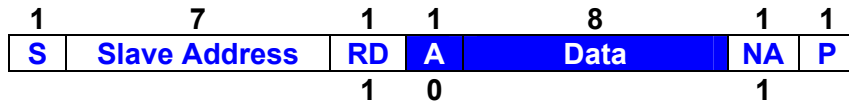

(b) Receive byte protocol

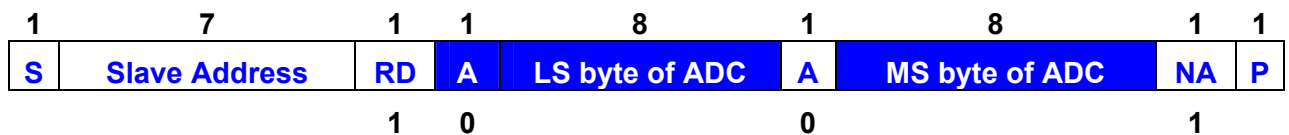

(c) Receive word (two bytes) protocol

**S** = start condition      **P** = stop condition      **Shaded** = slave transmission

**A** = acknowledge      **NA** = not acknowledge      **WR** = write      **RD** = read

Figure 11. Communication Protocol



**Communication Format**

ALS-PDIC17-79NB is capable of working as an I<sup>2</sup>C slave. Address of this device on I<sup>2</sup>C bus is always 0x39 (hexadecimal number 39). Registers of the slave device can be programmed by sending commands over I<sup>2</sup>C bus.

Figure 12 shows an I<sup>2</sup>C write operation. To write to an internal register of the slave device a command must be sent by an I<sup>2</sup>C master. As illustrated in Figure 12, the I<sup>2</sup>C write command begins with a start condition. After the start condition, seven bits of address are sent with MSB going first. RD / WRn (=Low) command bit follows the address bits. Upon receiving a valid address the slave device responds by driving SDA low for an ACK. After receiving an ACK, I<sup>2</sup>C master sends eight bits of data with MSB first. Upon receiving eight bits of data the slave device generates an ACK. I<sup>2</sup>C master terminates this write command with a stop condition.

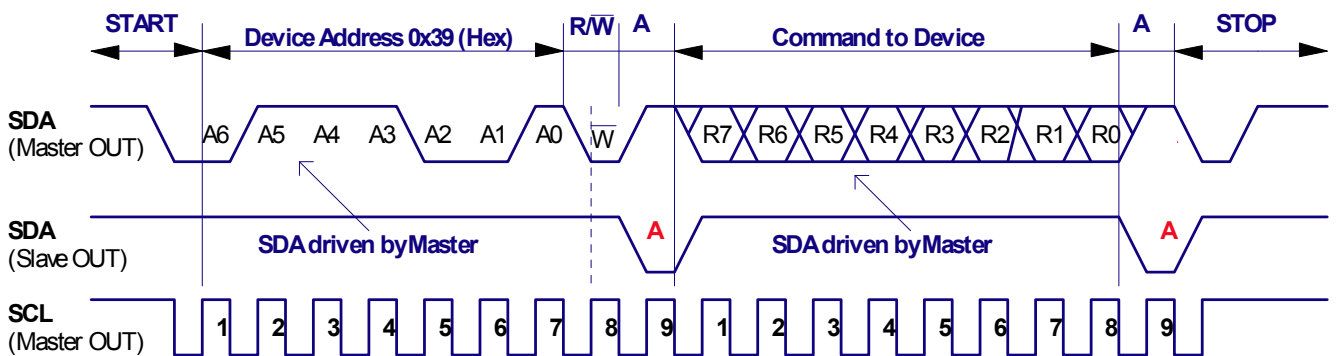

Figure 12. I<sup>2</sup>C Timing Diagram for Send Byte Format

Figure 13 shows an I<sup>2</sup>C read command sent by the master to the slave device. I<sup>2</sup>C read command begins with a start condition. After the start condition seven bits of address are sent by the master with MSB going first. After the address bits, RD / WRn command bit is sent. For a read command the RD / WRn bits is high. Upon receiving the address bits and RD / WRn command bits the slave device responds with an ACK. After sending an ACK, the slave device sends eight bits of data with MSB going first. After receiving the one byte data, the I<sup>2</sup>C master terminates this transaction by issuing a NACK command to indicate that the master only wanted to read one byte from the device. The master generates a stop condition to end this transaction.

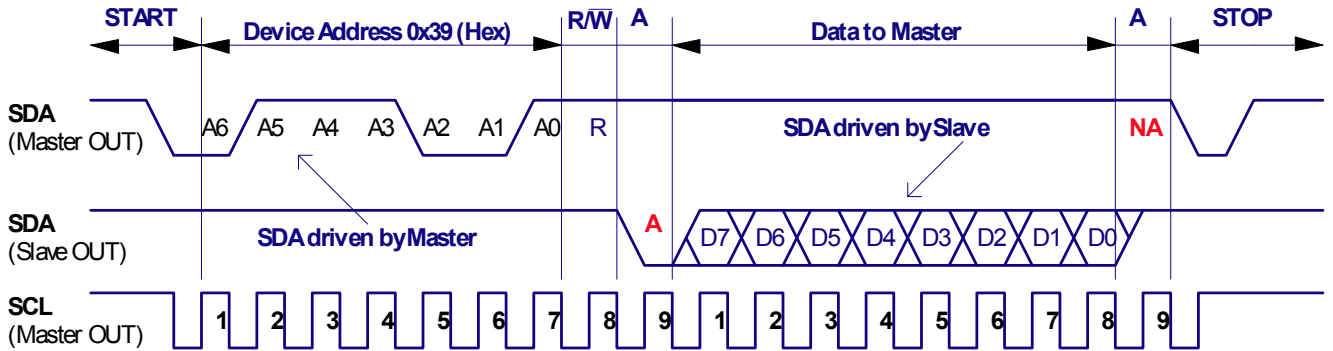

Figure 13 I<sup>2</sup>C Timing Diagram for Receive Byte Format

Ambient light intensity count value can be obtained by reading registers of this device. Ambient light intensity count is a 15-bit wide number plus a valid bit and hence word (two bytes) read operation is needed, as shown in Figure 14. After receiving the two byte data, the I<sup>2</sup>C master terminates this transaction by issuing a NACK command to indicate that the master only wanted to read two bytes from the device. The master generates a stop condition to end this transaction.

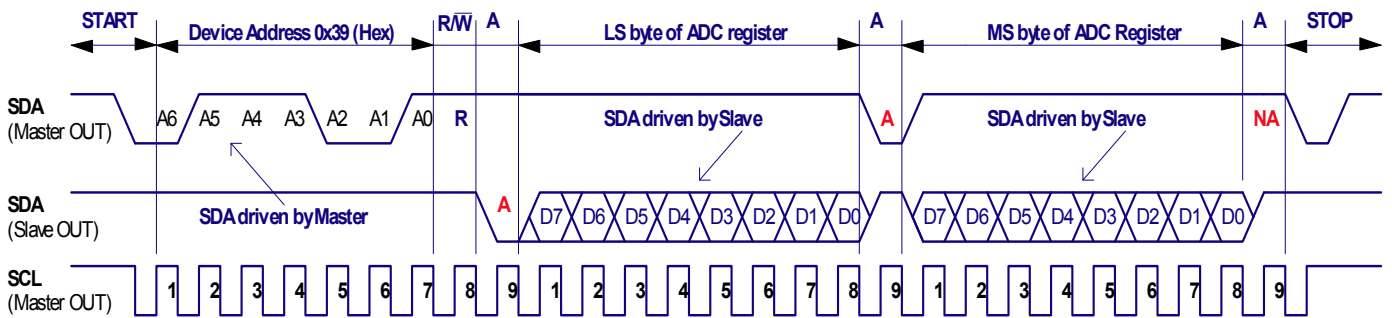

Figure 14. I<sup>2</sup>C Timing Diagram for Receive Word Format



LIGHTING FOREVER

# Surface - Mount I<sup>2</sup>C Digital Ambient Light Sensor

## ALS-PDI C17-79NB/ TR8

### Theory of Operation

The photocurrent, generated by the built-in photodiode while being illuminated, is proportionally converted to frequency; the digital frequency signal is then integrated by a 15-bit counter for a predetermined period of time (tint). This period of time is called integration time which can be adjusted by changing the nominal value of the resistor between the RINT and GND terminals. The converted data are read out through a two-wire, I2C Interface bus. Since the photodiode has been specially processed to suppress the spectral response in infrared region, the readout is very close to the photopic transfer function,  $v(\lambda)$ , which is the mathematic expression of human-eye's response to ambient light.

### Address Option for I<sup>2</sup>C

The I<sup>2</sup>C address is determined before placing an order; users can assign any one of the three addresses (0x39, 0x29, 0x40) for their specific application. Without any prior request for a specific I2C address, the default address is 0x39.

Table 1. Connecting options of I<sup>2</sup>C address

Address Pin Configuration	I2C Address
Floating	0x39 (default)
Tied to GND	0x29
Tied to VCC	0x44

### ADC Register

The ADC register contains 16 bits with a 15-bit wide data from D0 to D14 and a valid bit D15. The register is divided into two groups; D[15..8] is the most significant (MS) byte and D[7..0] is the least significant (LS) byte. See Table 2 for details.

Table 2. ADC Register Structure

Valid Bit	Data Bits			
D15	D14	D13 ~ D8	D7~D1	D0
	MSB		LSB	
Most Significant (MS) byte			Least Significant (LS) byte	



LIGHTING FOREVER

# Surface - Mount I<sup>2</sup>C Digital Ambient Light Sensor

ALS-PDI C17-79NB/ TR8

## Device Command

There are eight command codes are provided for I2C master to control the ambient light sensor. The specific function corresponding to each command code is elaborate in Table 3.

Table 3. Command Code List

Command Code	Function
1xxx_xxxx (binary code)	Shut-down mode, this is the default state after applying VDD power to the device. During shut-down mode, users can do the communication test. Except the MSB must be logic 1, the value written to the command register will not change any function and can be read back via the I <sup>2</sup> C bus by issuing <i>Receive Byte Protocol</i> .
0x0C	Activate the ambient light sensor and put the device in [continuous operation mode], The ADC register will be refreshed every tint integration time which is set by an external resistor Rext. See Table 4 for details.
0x04	Activate the ambient light sensor and put the device in [one time integration mode]. The integration time is controlled by I <sup>2</sup> C commands, start and stop integration.
0x08	Start integration: This command will reset the ADC register to 0x0000 and begin a new integration in [one time integration mode]. This is an invalid command in [continuous operation mode].
0x30	Stop integration: This command will stop the integration in [one time integration mode] and set the valid bit ( D[15] ) high. This is an invalid command in [continuous operation mode].
0x34	Reserved for future expansion.

## Programming Sequence

### Case 1: Using internal integration timing

- (1). After being powered on, the device will initially be in the shut-down mode (default setting).
- (2). To operate the device, issue an Send Byte protocol (see Figure 11-a) with the device address 0x39 followed by a command byte of 0x0C to activate the ambient light sensor and put the device into "continuous operation mode".
- (3). To read the ADC conversion result, issue an Receive Word protocol (see Figure 11-c) with the device address 0x39 followed by two-byte reading procedures.



LIGHTING FOREVER

## Surface - Mount I<sup>2</sup>C Digital Ambient Light Sensor

ALS-PDI C17-79NB/ TR8

- (4). If a conversion has not been completed since being activated, the valid bit ( D[15] ) will be 0 to indicate that the data is not valid. If there is a valid conversion result available, the valid bit ( D[15] ) will be set logic high, and the remaining 15 bits will represent valid data from the ADC register.
- (5). Data may be read repeatedly from the ADC register, and although it will remain valid, the ADC register will not be updated until a new conversion completes.

### Case 2: Using external integration timing

- (1). After being powered on, the device will initially be in the shut-down mode (default setting).
- (2). To operate the device, issue an Send Byte protocol (see Figure 11-a) with the device address 0x39 followed by a command byte of 0x04 to activate the ambient light sensor and put the device into "one time integration mode".
- (3). I<sup>2</sup>C master sends a "start integration command" to the salve device by issuing Send Byte protocol with the device address 0x39 followed by a command byte of 0x08.
- (4). After a period of user defined integration time, I<sup>2</sup>C master sends a "stop integration command" to the salve device by issuing Send Byte protocol with the device address 0x39 followed by a command byte of 0x30.
- (5). To read the ADC conversion result, issue an Receive Word protocol (see Figure 11-c) with the device address 0x39 followed by two-byte reading procedures.
- (6). If the stop integration command is not received by the device, the valid bit ( D[15] ) will be 0 to indicate that the data is not valid. If there is a valid conversion result available, the valid bit ( D[15] ) will be set logic high, and the remaining 15 bits will represent valid data from the ADC register.
- (7). Data may be read repeatedly from the ADC register, and although it will remain valid, the ADC register will not be updated until a new complete integration cycle has been carried out.

In both cases, the power consumption of the device can be reduced by issue an Send Byte protocol with the device address 0x39 followed by a data byte of 0x8C.

### Noise Rejection and Integration Time

In general, integrating type ADC's have an excellent noise rejection characteristics for periodic noise sources whose frequency is an integer multiple of the integration time. For instance, a 60Hz AC unwanted signal's sum from 0ms to  $n \cdot 16.66\text{ms}$  ( $n = 1, 2, \dots, ni$ ) is zero.



LIGHTING FOREVER

# Surface - Mount I<sup>2</sup>C Digital Ambient Light Sensor

## ALS-PDI C17-79NB/ TR8

Similarly, setting the ALS-PDIC17-79NB integration time to an integer multiple of periodic noise signal greatly improves the light sensor output signal in the presence of noise. The integration time,  $t_{int}$ , of the ALS-PDIC17-79NB is set by an external resistor  $R_{ext}$ . The maximum detection range is inversely proportional to the integration time; that means the longer integration time the lower detection range.

Table 4.  $R_{ext}$  Resistor Selection Guide

$R_{ext}$ (k $\Omega$ )	Integration time ( mS )	Detection range ( lux )	Resolution ( lux / count )
50 (min.)	50	220,000	6.71
100 (recommended)	100	110,000	3.36
200	200	55,000	1.68
300	300	36,600	1.12
400 (max.)	400	27,500	0.84

In order to achieve both 60Hz and 50Hz AC rejection, the integration time needs to be adjusted to coincide with an integer multiple of the AC noise cycle times. To determine a suitable integration time,  $t_{int}$ , that will ignore the presence of both 60Hz and 50Hz noise, users can use the formula:

$$t_{int} = n(1/60\text{Hz}) = m(1/50\text{Hz}), \text{ where } n \text{ and } m \text{ are integers.}$$

$$n/m = 60\text{Hz}/50\text{Hz} = 6/5.$$

The first instance of integer values at which  $t_{int}$  rejects both 60Hz and 50Hz is when  $m = 5$ , and  $n = 6$ , thus,

$$t_{int} = 6(1/60\text{Hz}) = 5(1/50\text{Hz}) = 100\text{ms},$$

$$R_{ext} = t_{int} * (100\text{k}\Omega/100\text{ms}) = 100\text{k}\Omega, \text{ (see Table 4)}$$

By populating  $R_{ext} = 100\text{k}\Omega$ , ALS-PDIC17-79NB defaults to 100ms integration time in continuous operation mode, and will reject the presence of both 60Hz and 50Hz power line signals. When working in one-time integration mode, the master must control the integration time to be an integer multiple of 100mS.

Power Supply Decoupling and Layout

The power supply lines must be decoupled with capacitors, 4.7uF and 0.1uF, placed as close to the device package as possible. The bypass capacitor should have low effective series resistance (ESR) and effective series inductance (ESI), such as the common ceramic types, which provide a low impedance path to ground at high frequencies to handle transient currents caused by internal logic switching. ALS-PDI C17-79NB is relatively insensitive to layout. Like other I2C devices, it is intended to provide excellent performance even in significantly noisy environments. There are only a few considerations that will ensure best performance. Route the supply and I2C traces as far as possible from all sources of noise. Use two power-supply decoupling capacitors, 4.7μF and 0.1μF, placed close to the device.

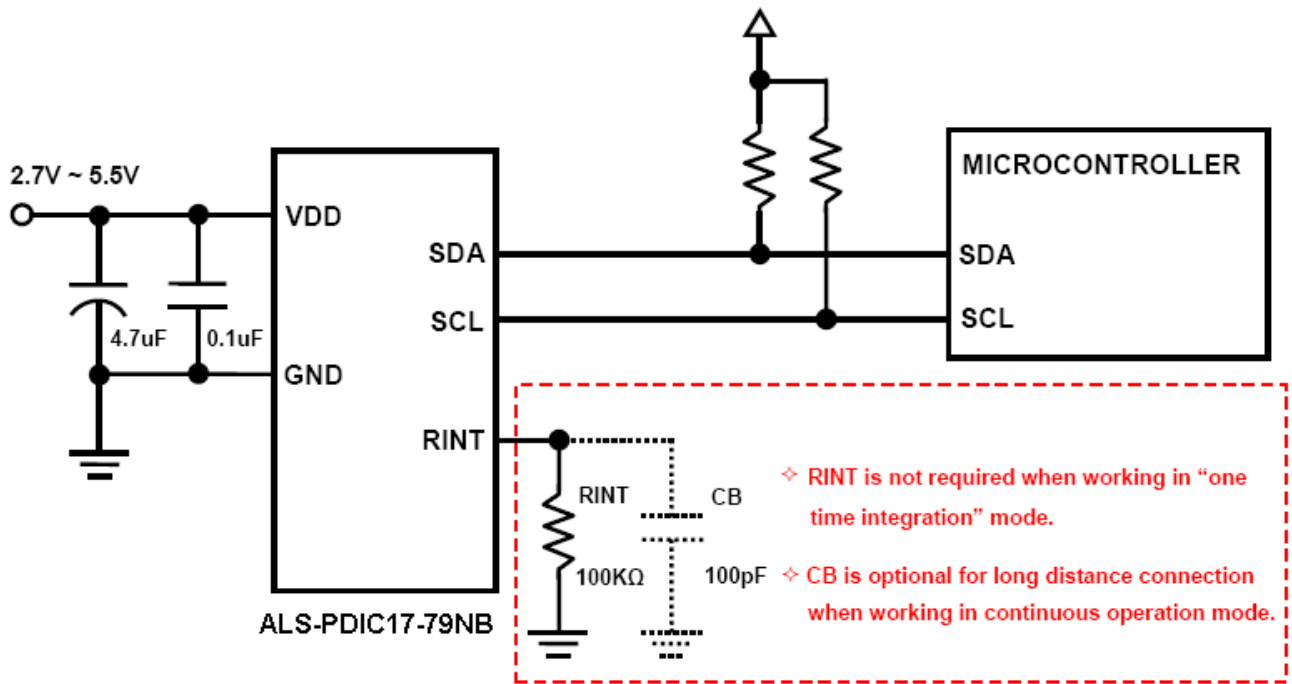

### Optical window dimensions

In order to prevent ALS performance being affected by improper window design, some constrains on the dimensions and design of the window is as an example shown below,

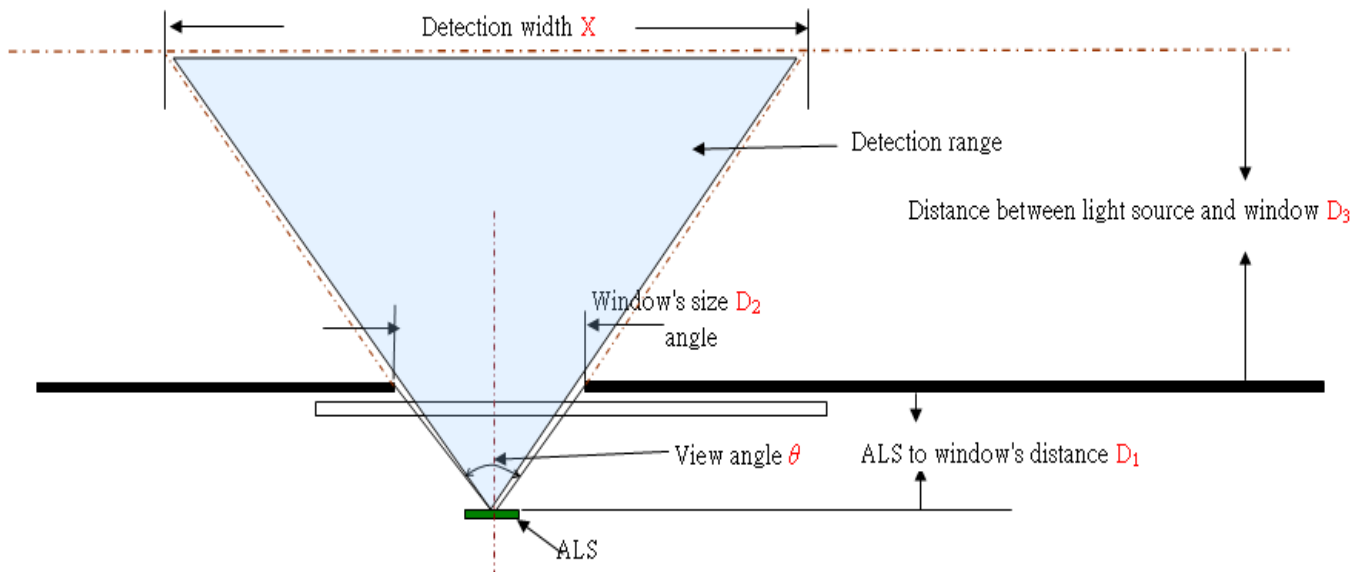

$$D_2 = \frac{D_1}{\tan\left(90^\circ - \frac{\theta}{2}\right)} \times 2$$

$$X = \frac{(D_3 + D_1)}{\tan\left(90^\circ - \frac{\theta}{2}\right)} \times 2$$

θ: View Angle

D<sub>1</sub> : Distance between ALS and Windows

D<sub>2</sub> : Window's Size

D<sub>3</sub> : Distance between light source and window

X : Detection Width



**Recommended method of storage**

1. Do not open moisture proof bag before devices are ready to use.
2. Shelf life in sealed bag from the bag seal date:  
18 months at 10°C~30°C and < 90% RH.
3. After opening the package, the devices must be stored at 10°C~30°C and ≤ 60%RH, and used within 168 hours (floor life).
4. If the moisture absorbent material (desiccant material) has faded or unopened bag has exceeded the shelf life or devices (out of bag) have exceeded the floor life, baking treatment is required.
5. If baking is required, refer to IPC/JEDEC J-STD-033 for bake procedure or recommend the following conditions:  
192 hours at 40°C +5/-0°C and < 5 % RH (reeled/tubed/loose units) or  
96 hours at 60°C ± 5°C and < 5 % RH (reeled/tubed/loose units) or  
24 hours at 125°C ± 5°C, not suitable for reel or tubes.

**Recommended Solder Profile**

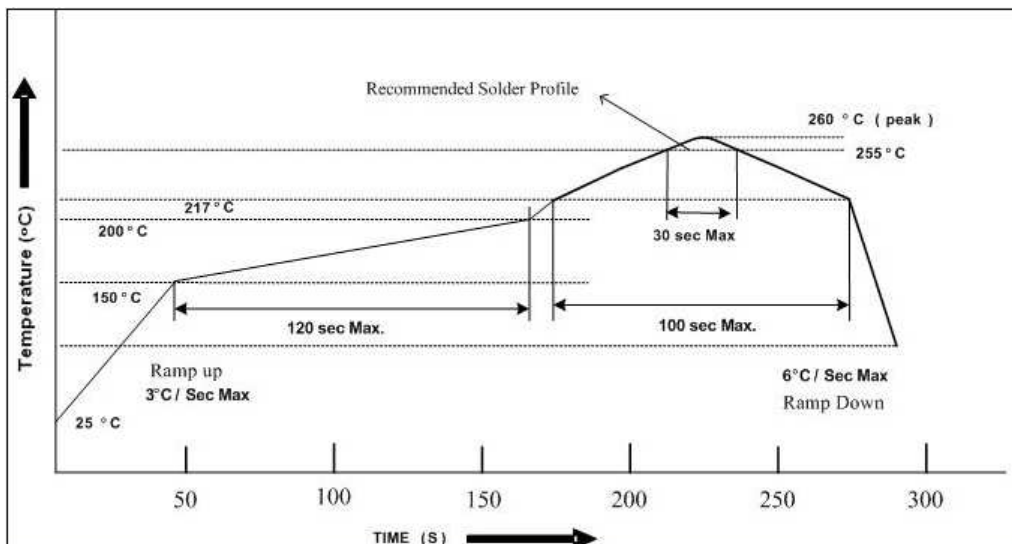

Notice:

- (1) Reflow soldering should not be done more than two times.
- (2) When soldering, do not put stress on the devices during heating.
- (3) After soldering, do not warp the circuit board.

## Soldering Iron

Each terminal is to go to the tip of soldering iron temperature less than 350°C for 3 seconds within once in less than the soldering iron capacity 25W. Leave two seconds and more intervals, and do soldering of each terminal. Be careful because the damage of the product is often started at the time of the hand solder.

## Repairing

Repair should not be done after the device have been soldered. When repairing is unavoidable, a double-head soldering iron should be used (as below figure). It should be confirmed beforehand whether the characteristics of the device will or will not be damaged by repairing.

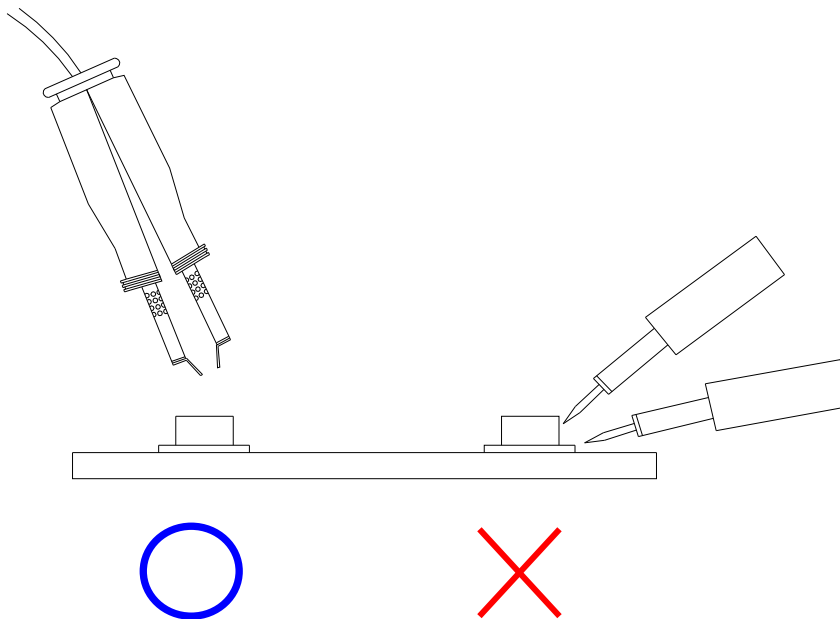



LIGHTING FOREVER

# Surface - Mount I<sup>2</sup>C Digital Ambient Light Sensor

## ALS-PDI C17-79NB/ TR8

### Packing Quantity Specification

2000 PCS/ 1 Reel

### Label Format

**Pb** **EVERLIGHT** **12**  
LIGHTING FOREVER

CPN: XXXXXXXXXXXX  
P/N: SXXXXXXXXXX

XXX-XXXXXXXX/XXXX-XX/XXXX

QTY: X000 CAT: XX  
HUE: XX-X  
REF: XXXXXXXXXXXX

LOT NO: XX81217XXXXXXXXX

REFERENCE: BTP08121712345

**RoHS**

**MSL-3**

### Reel Dimensions

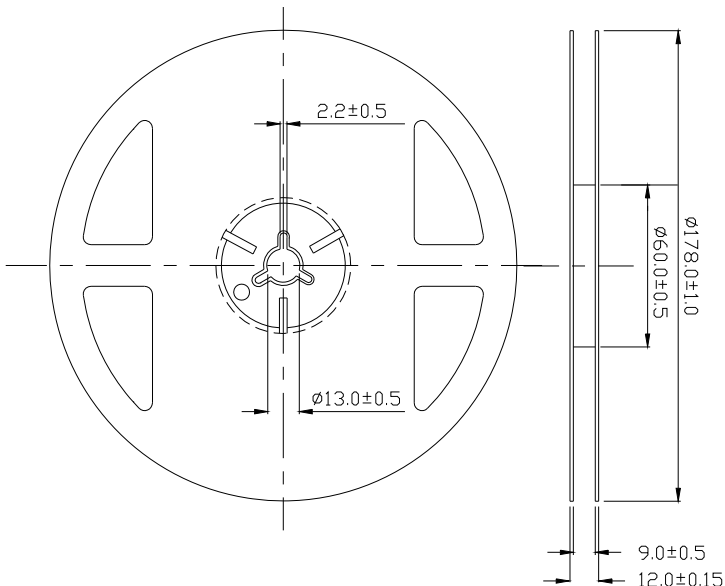

Unit: mm

Tolerance:  $\pm 0.1$  mm



LIGHTING FOREVER

# Surface - Mount I<sup>2</sup>C Digital Ambient Light Sensor

## ALS-PDI C17-79NB/ TR8

### Tape Dimensions

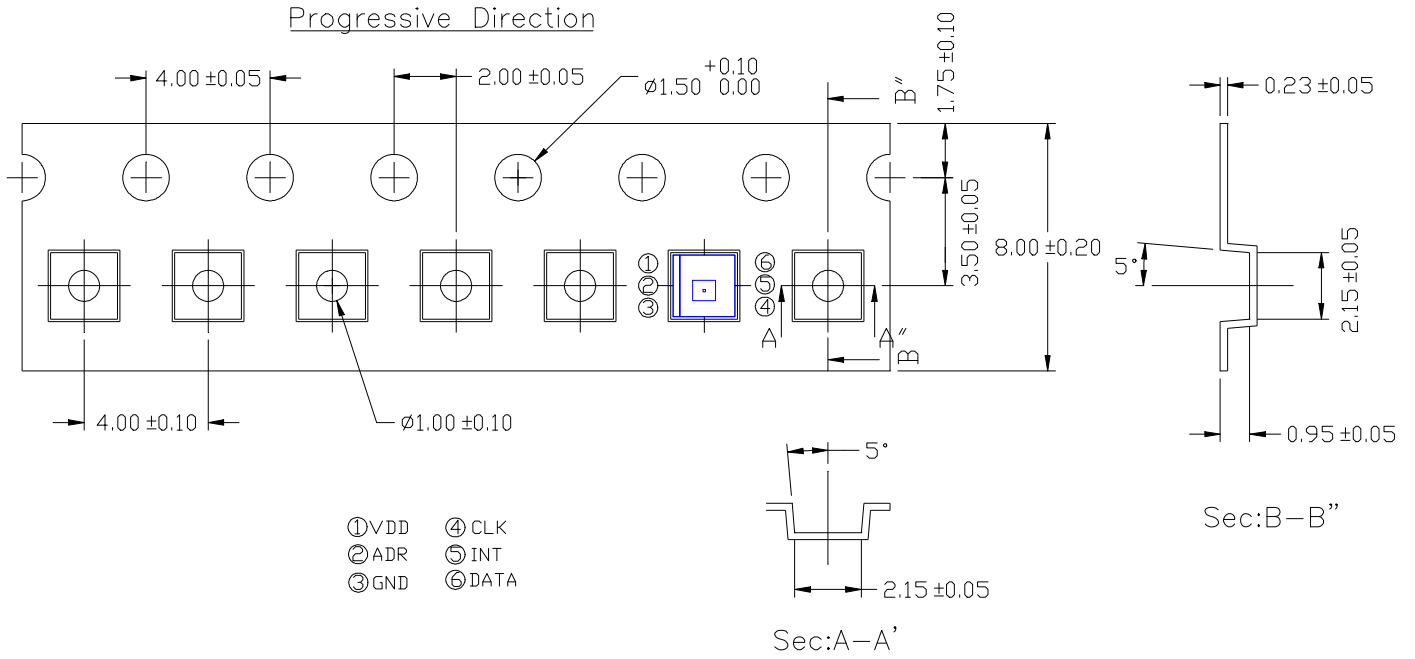

Unit: mm



LIGHTING FOREVER

## Surface - Mount I<sup>2</sup>C Digital Ambient Light Sensor

**ALS-PDI C17-79NB/ TR8**

---

Note:

1. Above specification may be changed without notice. EVERLIGHT will reserve authority on material change for above specification.
2. When using this product, please observe the absolute maximum ratings and the instructions for using outlined in these specification sheets. EVERLIGHT assumes no responsibility for any damage resulting from use of the product which does not comply with the absolute maximum ratings and the instructions included in these specification sheets.
3. These specification sheets include materials protected under copyright of EVERLIGHT corporation. Please don't reproduce or cause anyone to reproduce them without EVERLIGHT's consent.