

Features

- Light to Current, analog output
- Good output linearity across wide illumination range
- Operation temperature performance, -30°C to 85°C
- Wide supply voltage range, 3V to 24V
- High efficiency light current output
- Lower dark current 0.1uA
- Lower cost
- Size : 5mm Lamp (Flat lens)
- RoHS compliant and Pb Free package



Description

The ALS-PDT243-3C/L451 is an ambient light sensor using a photo transistor in a DIP package. It is used to replace traditional CdS sensors, since Cadmium is no longer allowed by RoHS.

Applications

- Detection of ambient light to control electrical unit
 - Lighting devices – Road lamp, Night lamp
 - Consumer device – LCD TV, Toys, Gaming

Package Dimensions

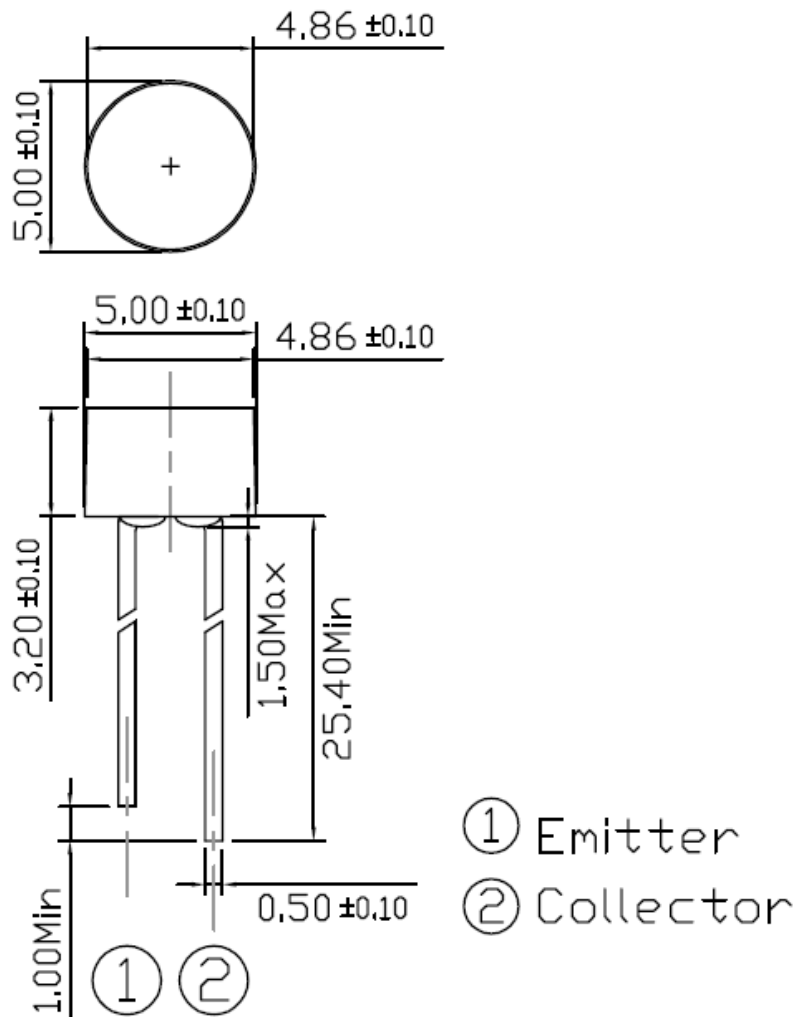

- Notes:**
1. All dimensions are in millimeters
 2. Tolerances unless dimensions ± 0.1 mm

Absolute Maximum Ratings (Ta=25°C)

Parameter	Symbol	Rating	Unit
Operating Temperature Range	T _{opr}	-30~85	°C
Storage Temperature Range	T _{stg}	-30~100	°C
Collector-Emitter Breakdown Voltage	V _{(BR)CEO}	60	V
Emitter-Collector Breakdown Voltage	V _{(BR)ECO}	8	V
Supply Voltage	V _{cc}	2~24	V
Soldering Temperature Range	T _{sol}	260	°C

Recommended Operating Conditions (Ta=25°C)

Parameter	Symbol	Min.	Max.	Unit
Operating Temperature	T _{opr}	-30	+85	°C
Supply Voltage	V _{cc}	3	24	V

Electrical and Optical Characteristics (Ta=25°C)

Parameter	Symbol	MIN.	TYP.	MAX.	Unit	Test Condition
Collector -Emitter Breakdown Voltage	BV_{CEO}	---	60	---	V	$I_{ce0}=500\mu A$
Dark Current	I_{CEO}	---	---	0.1	μA	$V_{CE}=20V, E_v=0Lux$
Collector-Emitter Saturation Voltage	$V_{CE(sat)}$	---	---	1	V	$I_C=50mA, E_v=1000Lux$
Light Current	I_{PH1}	22	---	55	μA	$V_{CE}=5V, E_v=10Lux$ [Note1]
	I_{PH2}	285	---	720	μA	$V_{CE}=5V, E_v=100Lux$ [Note1]
	I_{PH3}	---	13	---	mA	$V_{CE}=5V, E_v=100Lux$ [Note2]
Saturation Output Voltage	V_o	---	4.7	---	V	$V_{CE}=5V, E_v=1000Lux$ $R_L=2K\Omega$ [Note2]
Peak Sensitivity Wavelength	λ_p	---	790	---	nm	
Sensitivity Wavelength Range	λ	400	---	1020	nm	
Angle of half Sensitivity	$2\theta_{1/2}$	---	110	---	Deg.	

Notice:

1. White Fluorescent light (Color Temperature = 6500K) is used as light source. However, White LED is substituted in mass production.
2. Illuminance by CIE standard illuminant-A / 2856K, incandescent lamp.

Recommend Application Circuit (ALS)

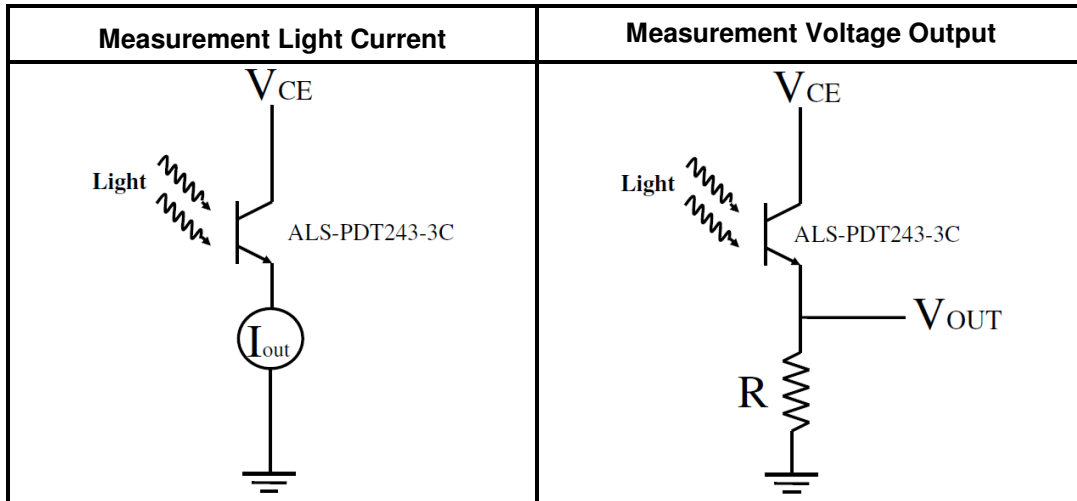

Recommend Application Circuit (CDS)

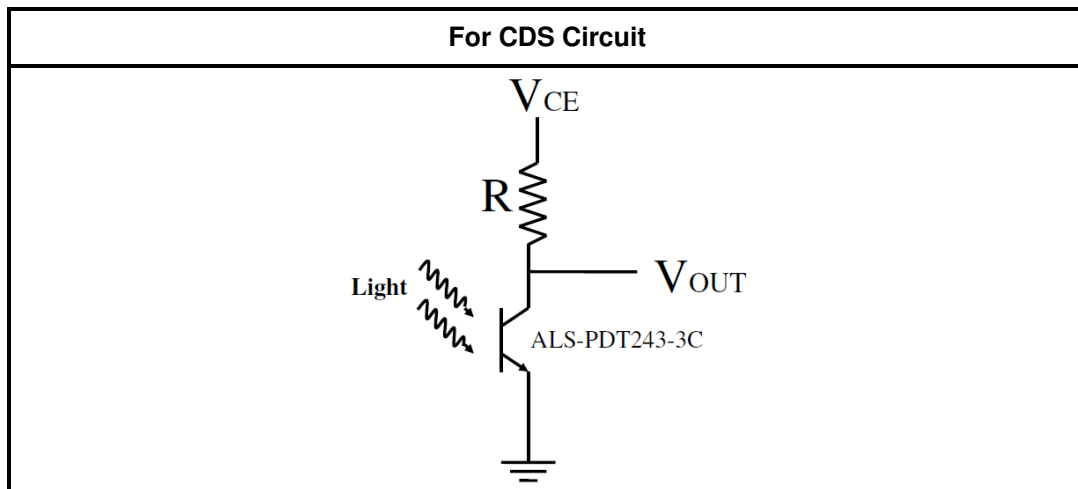

Electrical and Optical Characteristics

Fig.1 Light Current vs. Illuminance

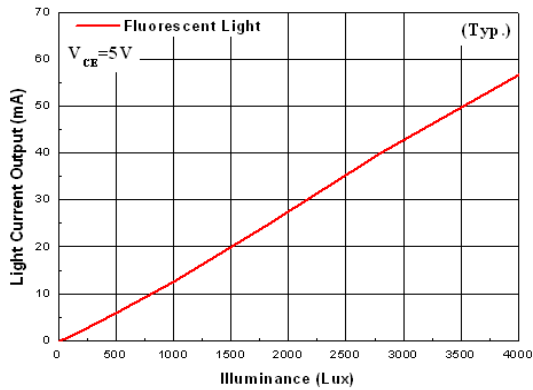

Fig.2 Dark Current vs. Temperature

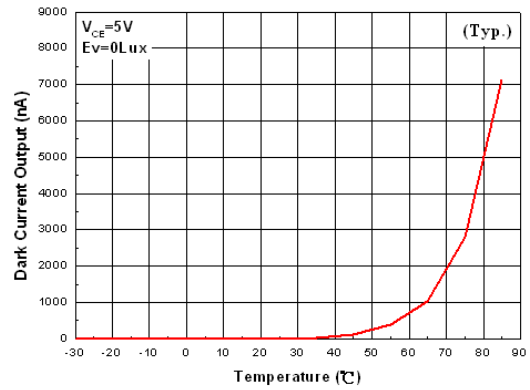

Fig.3 Light current vs. Temperature

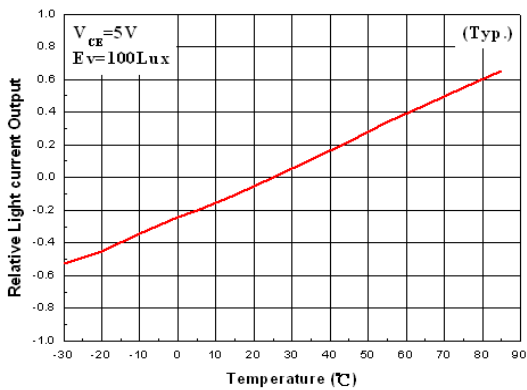

Fig.4 Light current vs. Supply Voltage

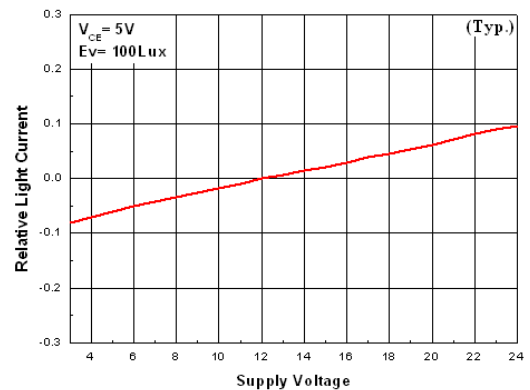

Fig.5 Spectral Response

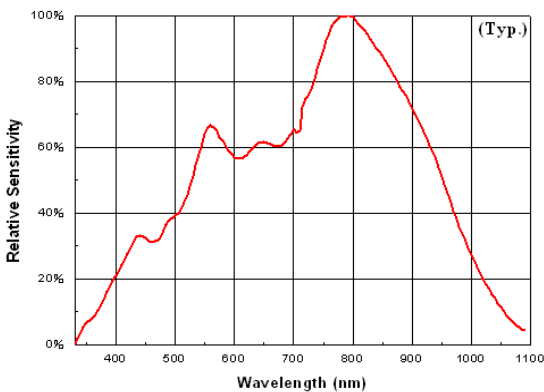

Fig.6 Voltage Output vs. Illuminance

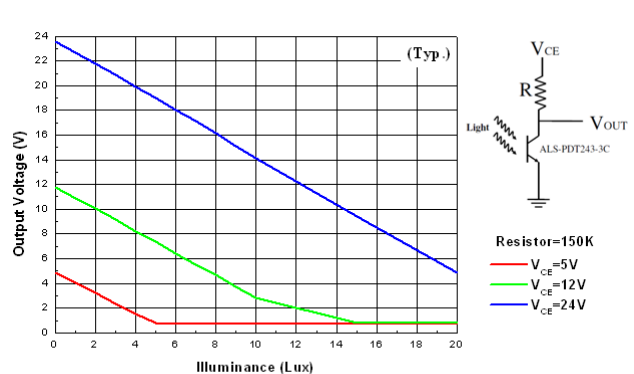
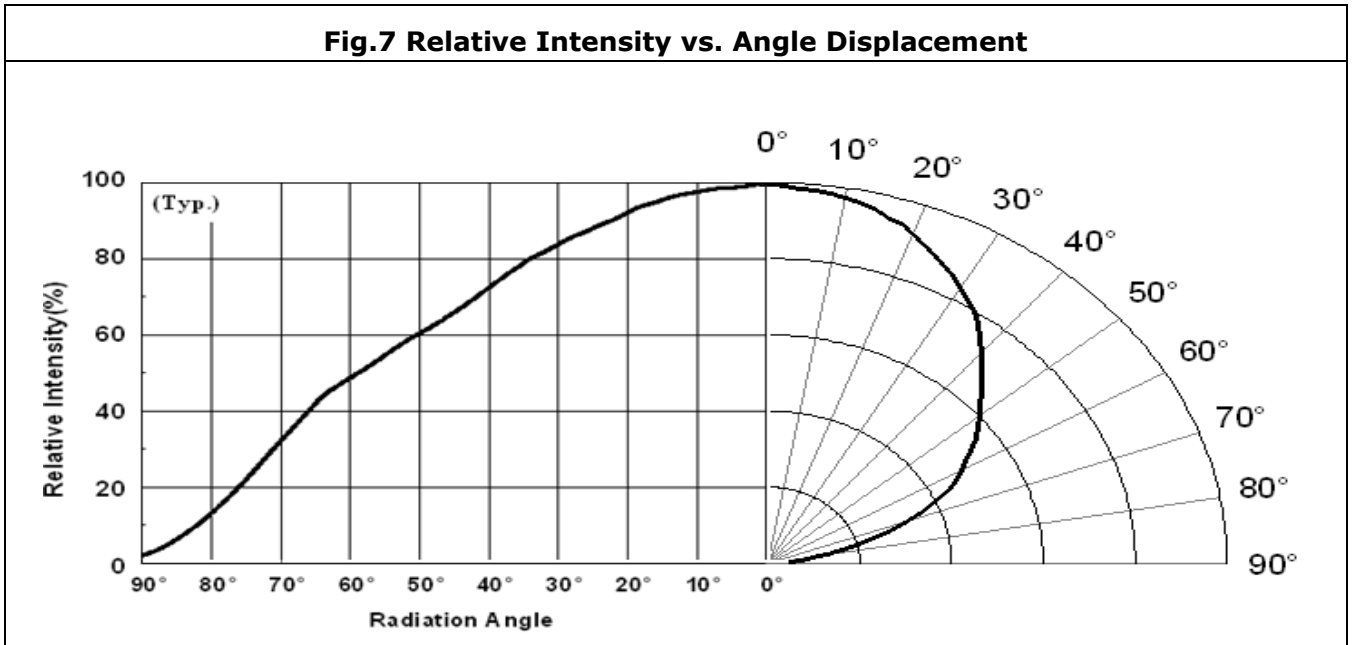

Fig.7 Relative Intensity vs. Angle Displacement



Packing Quantity Specification

1. 500PCS/1Bag · 5Bags/1Box
2. 10Boxes/1Carton

Label Format



EVERLIGHT

10

CPN:



P/N:



RoHS

QTY:



LOT NO:



Reference:



CAT:

HUE:

REF:

CPN: Customer's Production Number

P/N : Production Number

QTY: Packing Quantity

CAT: Ranks

HUE: Peak Wavelength

REF: Reference

LOT No: Lot Number

Notes

1. Above specification may be changed without notice. EVERLIGHT will reserve authority on material change for above specification.
2. When using this product, please observe the absolute maximum ratings and the instructions for using outlined in these specification sheets. EVERLIGHT assumes no responsibility for any damage resulting from use of the product which does not comply with the absolute maximum ratings and instructions included in these specification sheets.
3. These specification sheets include materials protected under copyright of EVERLIGHT corporation. Please don't reproduce or cause anyone to reproduce them without EVERLIGHT's consent.