

EHP-69 Series

EHP-69/GT01C-P01/TR

Received
<input checked="" type="checkbox"/> MASS PRODUCTION
<input type="checkbox"/> PRELIMINARY
<input type="checkbox"/> CUSTOMER DESIGN
DEVICE NO. : *
PAGE : 12

Revised record		
REV.	DESCRIPTION	RELEASE DATE
1	New spec	2011.04.08
2	Modify V_F and white bin label	2011.05.31
3	Modify Luminous Flux bin label	2011.06.02
4	Modify typical electro-optical characteristics curves increase lux with lm, modify tolerances unless mentioned $\pm 0.15\text{mm}$. Unit =mm °	2011.08.30
5	Modify the product dimension of height to 1.70mm and change format °	2011.11.17

EHP-69 Series

EHP-69/GT01C-P01/TR



Features

- ◆ Small & compact package and with high efficiency
- ◆ Typical luminous flux: 100 lm @ 500mA
- ◆ Typical color temperature: 6000 K@500mA
- ◆ Optical efficiency@500mA : 65 lm/W
- ◆ ESD protection (according to JEDEC 3b) up to 2KV
- ◆ Moisture Sensitivity Level (MSL) Class 3
- ◆ Grouping parameter: Total luminous flux, Color coordinates, Forward voltage.
- ◆ RoHS compliant & Pb free

Description

- ◆ Encapsulating Resin: Silicone resin with phosphor
- ◆ Electrodes: Ag plating
- ◆ Die attach: Silver paste
- ◆ Chip: InGaN

Applications

- ◆ Camera flash light /strobe light for mobile devices
- ◆ Torch light for DV(Digital Video) application
- ◆ Signal and Symbol Luminaries for orientation maker lights (e.g. steps, exit ways, etc.)

Device Selection Guide

Chip Materials	Emitted Color
InGaN	Shiny White

Absolute Maximum Ratings (Ts=25°C)

Parameter	Symbol	Rating	Unit
DC operating Current(Torch Mode) ₍₁₎	I _F	350	mA
Peak Pulsed Forward Current(Pulse Mode) ₍₂₎	I _{pulse}	500	mA
ESD Resistance (JEDEC 3b)	V _B	2000	V
Reverse Voltage	V _R	Note 3	V
Junction Temperature	T _J	125	°C
Operating Temperature	T _{OP}	-40 ~ +85	°C
Storage Temperature	T _{stg}	-40 ~ +100	°C
Soldering Temperature	T _{sol}	260	°C
Allowable Reflow Cycles	N/A	2	

Notes:

1. Pulse time > 50ms, T_{soldering} = 25°C
2. 1 Duty ≤ 0.1, pulse width ≤ 50ms, T_{soldering} = 25°C
3. EHP-69 series are not designed for reverse bias used.
4. All specification are assured by reliability test for 1000hr, IV degradation less than 30%
5. All reliability items are tested under good thermal management with 1.0x1.0 cm² MCPCB
6. Operate LED component at maximum rating conditions continuously will cause possible permanent damage and de-rating parameters. Exercise multiple maximum rating parameters simultaneously should not be allowed. When maximum rating parameters are applied over a long period will result potential reliability iss

JEDEC Moisture Sensitivity

Floor Life			Soak Requirements Standard	
Level	Time (hours)	Conditions	Time (hours)	Conditions
3	168	≤ 30°C/ 60%RH	192 +5/-0	30°C/ 60%RH

Electro-Optical Characteristics (Ts=25°C)

Parameter	Symbol	Min.	Typ.	Max.	Unit	Condition
Luminous Flux ₍₁₎	I _v	80	100	140	lm	IF = 500mA ₍₃₎
Forward Voltage ₍₂₎	V _F	2.95	----	4.15	V	
Color Temperature	CCT	4500	----	7000	K	

Forward Voltage Binning

Bin	Min.	Typ.	Max.	Unit	Condition
2932	2.95	----	3.25	V	IF = 500mA
3235	3.25	----	3.55		
3538	3.55	----	3.85		
3841	3.85	----	4.15		

Luminous Flux Binning

Bin	Min.	Typ.	Max.	Unit	Condition
F8	80	----	90	Lm	IF = 500mA
F9	90	----	100		
J1	100	----	120		
J2	120	----	140		

Note.

- Brightness measurement tolerance: ±10%.
- Forward Voltage measurement tolerance: ±0.1V.
- 1 Duty ≤ 0.1, pulse width ≤ 50ms, Tsoldering = 25°C

White Bin Structure

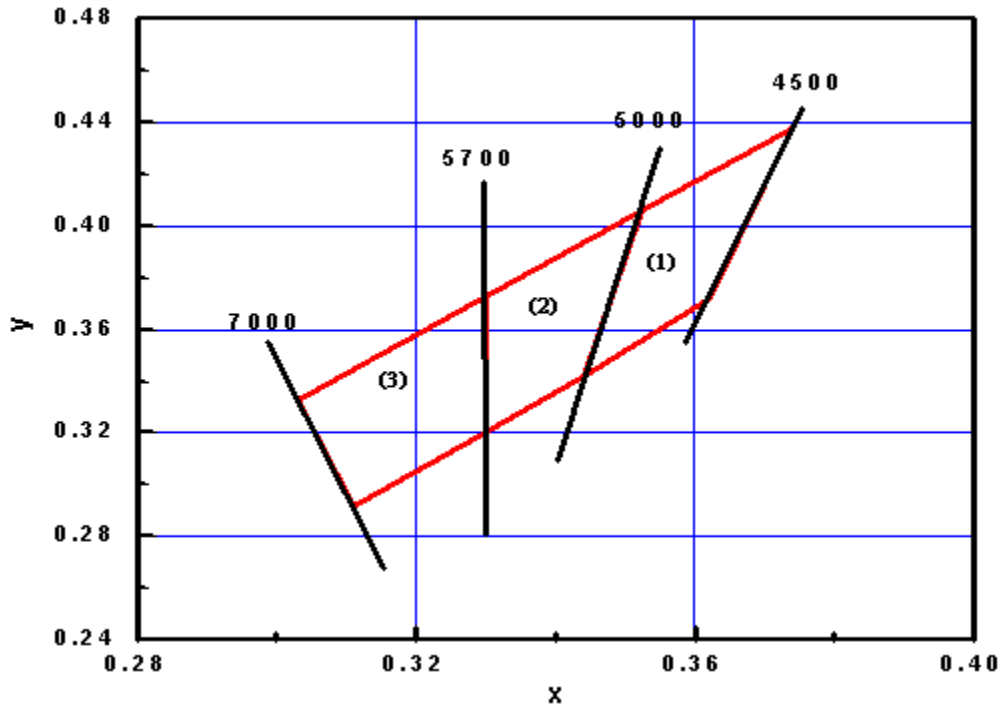

Cool-White Bin Coordinate

Bin	CIE X	CIE Y
4550 (1)	0.3738	0.4378
	0.3524	0.4061
	0.3440	0.3420
	0.3620	0.3720
Reference Range: 4500~5000K		
Bin	CIE X	CIE Y
5770 (3)	0.303	0.333
	0.33	0.373
	0.33	0.32
	0.311	0.292
Reference Range: 5700~7000K		

Bin	CIE X	CIE Y
5057 (2)	0.3524	0.4061
	0.3300	0.3730
	0.3300	0.3200
	0.3440	0.3420
Reference Range: 5000~5700K		

Notes:

1. Color coordinates measurement allowance : ± 0.01
2. Color bins are defined at $I_F=500\text{mA}$ and 50ms pulse operation condition

Typical Electro-Optical Characteristics Curves

Relative Spectral Distribution,
 $I_F=500\text{mA}$

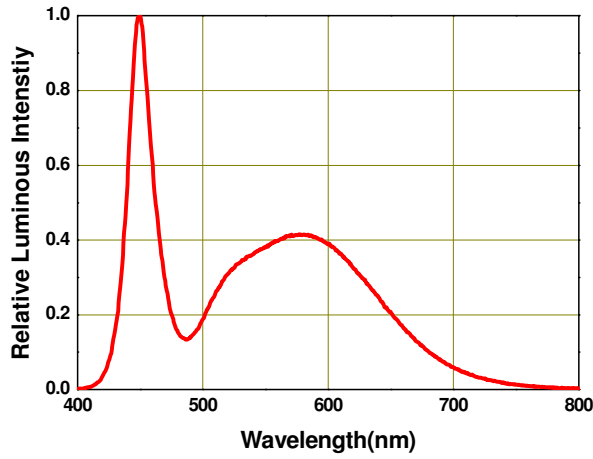

Forward Voltage vs. Forward Current

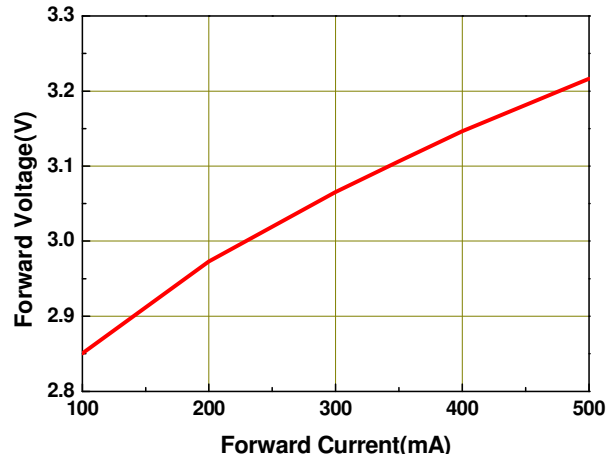

Relative Luminous Intensity vs Forward Current

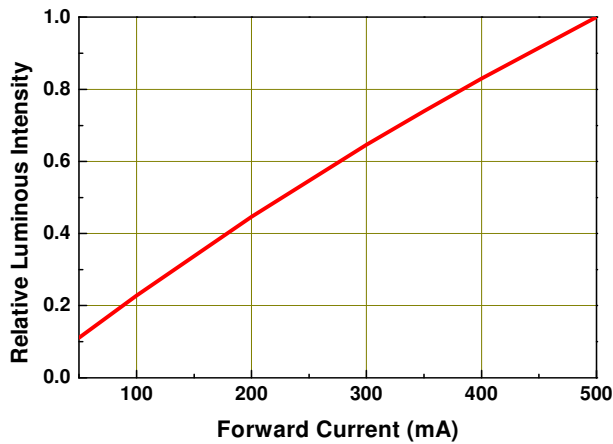

Correlated Color Temperature (CCT) vs. Forward current

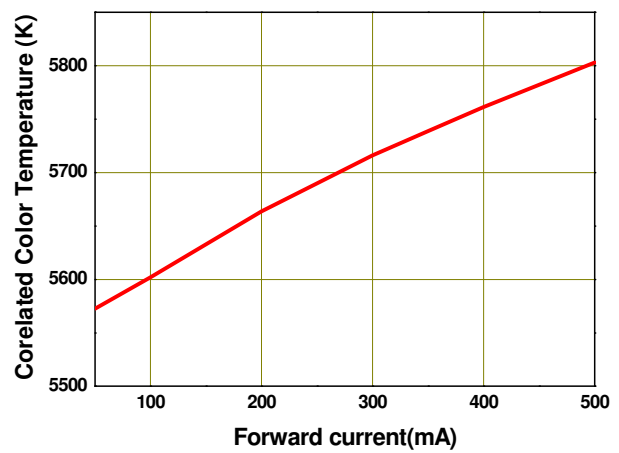

Note.

1. Data was tested at pulse time = 50ms
2. Data was tested under superior thermal management, $T_{\text{soldering}} < 70^{\circ}\text{C}$.

Typical Representative Spatial Radiation Pattern

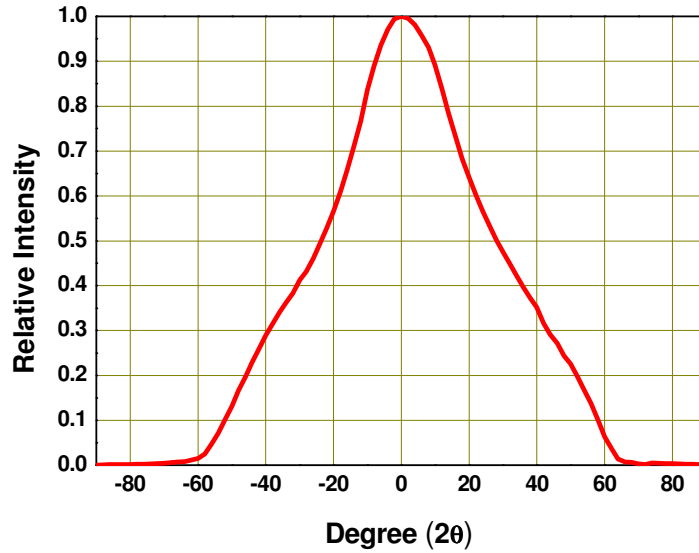

Note.

1. $2\theta_{1/2}$ is the off axis angle from lamp centerline where the luminous intensity is 1/2 of the peak value.
2. Viewing angle tolerance is $\pm 10^\circ$.

Luminous Intensity(lm) VS Center lux(lux)

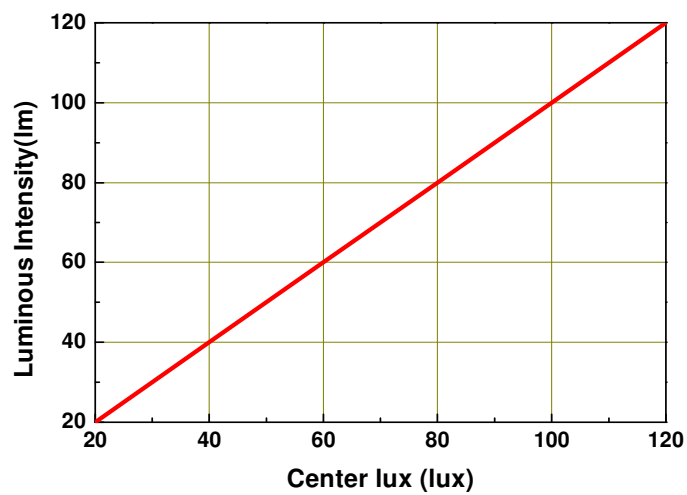

Mechanical Dimension

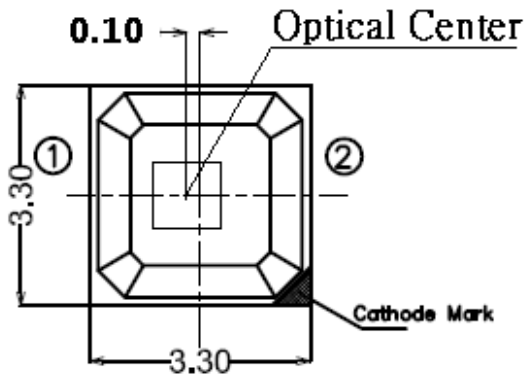

Polarity

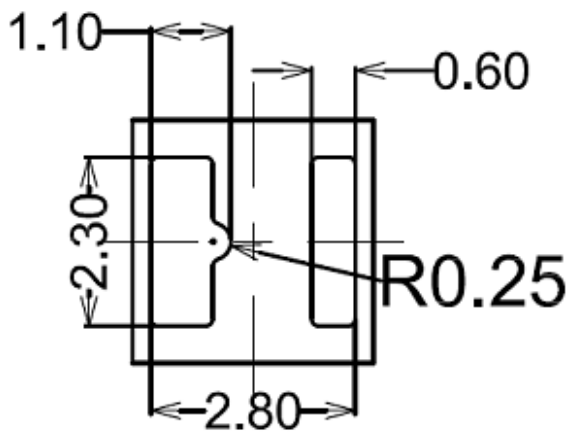
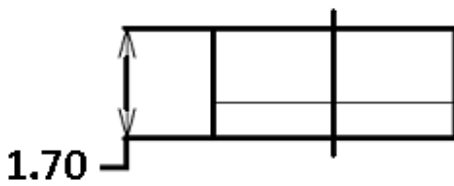

Bot. view

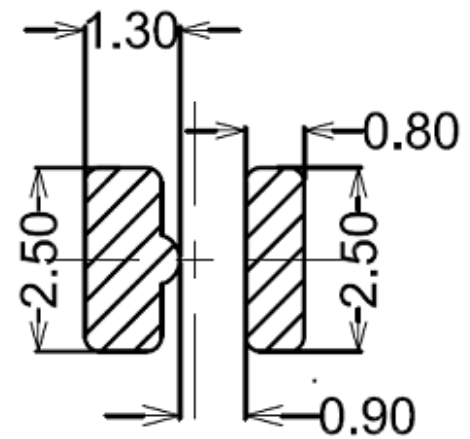

Soldering patterns

Note: Tolerances unless mentioned ± 0.15 mm. Unit = mm

Moisture Resistant Packing Materials

Label Explanation



CPN : Customer's Production Number

P/N : Production Number

QTY : Packing Quantity

CAT: Rank of Luminous Flux

HUE: Color Rank

REF: Rank of Forward Voltage

LOT No: Lot Number

MADE IN Production Place

TAIWAN:

Reel Dimensions

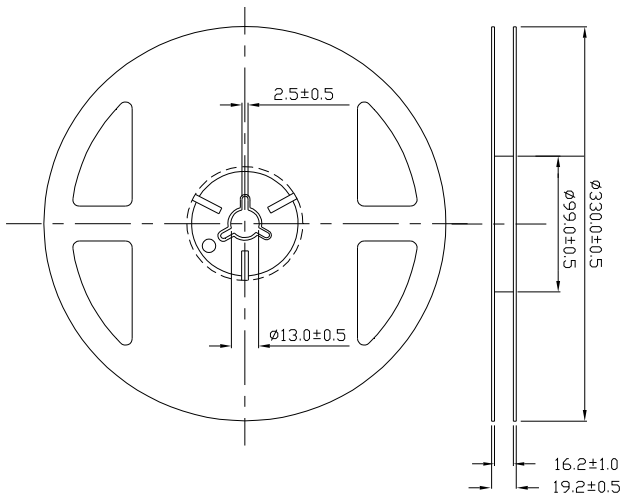

Carrier Tape Dimensions: Loaded Quantity 1000 pcs Per Reel

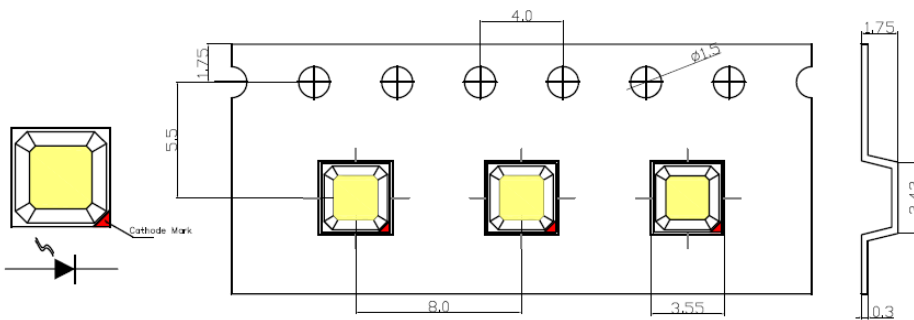

Note: Tolerances unless mentioned ± 0.1 mm. Unit = mm

Moisture Resistant Packaging

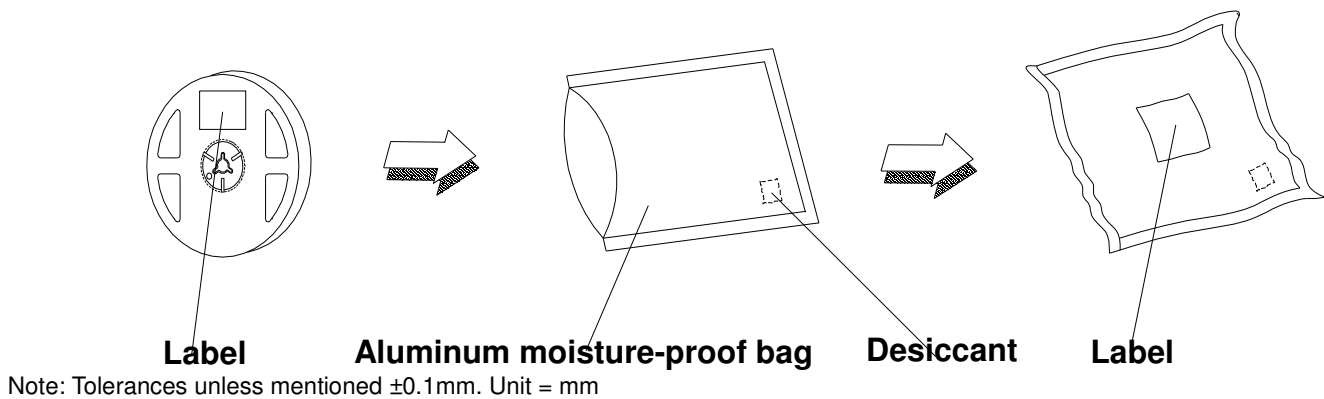

Precautions for Use

1. Over-current-proof

Although the EHP-69 series has a conductive ESD protection mechanism, customer must not use the device in reverse and should apply resistors for extra protection. Otherwise, slight voltage shifts may cause significant current change resulting in burn out failure.

2. Storage

- i. Do not open the moisture proof bag before the devices are ready to use.
- ii. Before the package is opened, LEDs should be stored at temperatures less than 30°C and

- humidity less than 90%.
- iii. LEDs should be used within a year.
- iv. After the package is opened, LEDs should be stored at temperatures less than 30°C and humidity less than 60%.
- v. LEDs should be used within 168 hours (7 days) after the package is opened.
- vi. If the moisture absorbent material (silicone gel) has faded away or LEDs have exceeded the storage time, baking treatment should be implemented based on the following conditions:
pre-curing at 60±5°C for 24 hours.

3. Thermal Management

- i. For maintaining the high flux output and achieving reliability, EHP-69 series LEDs should be mounted on a metal core printed circuit board (MCPCB) or other kinds of heat sink with proper thermal connection to dissipate approximately 1W of thermal energy at 350mA operation.
- ii. Heat dissipation or thermal conduction design is strongly recommended on MCPCB for reflow soldering purposes.

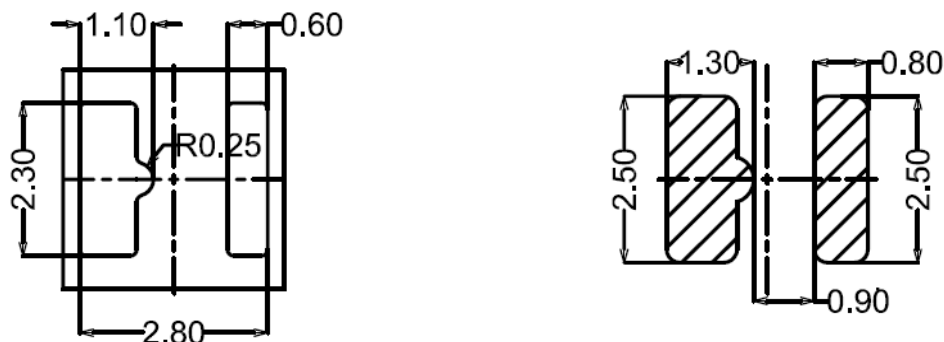

■ Temperature of soldering pad should be controlled under 70°C

- iii. Sufficient thermal management must be implemented. Otherwise, the junction temperature of die may exceed over the limit at high current driving conditions and the LEDs' lifetime may be decrease dramatically.
- iv. For further thermal management suggestions, please consult the Everlight Design Guide or local representatives for assistance.
- v. The solder pad should be controlled below 70°C when turn on the device, or the die junction temperature will be over the limit under large electronic driving and LED lifetime will decrease critically.

4. Proper Handling

To avoid contamination of materials, damage of internal components, and shortening of LED lifetime, do not subject LEDs to conditions as those listed below.

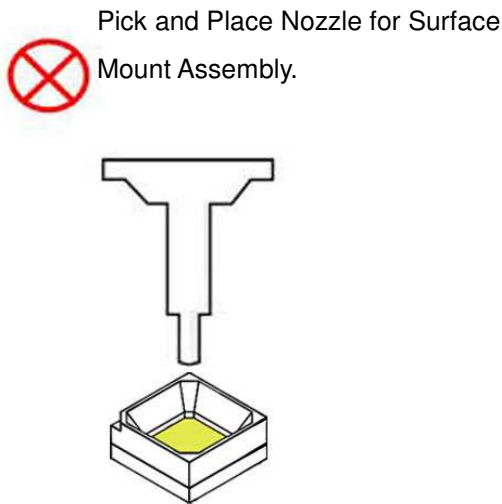

Avoid directly contacting with nozzle.

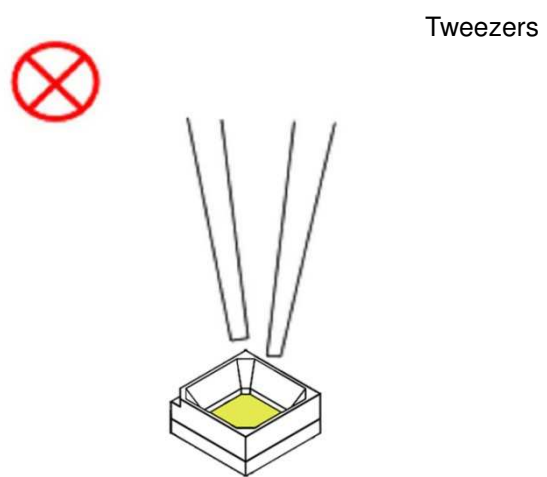

Do not touch the resin to avoid scratching or other damage.

5. Reflow Soldering Process

- EHP-69 series are suitable for SMT process.
- Curing of glue in oven according to standard operation flow processes.

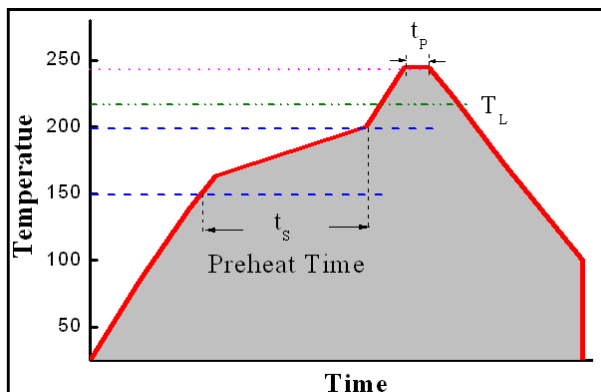

Profile Feature	Lead Free Assembly
Ramp-Up Rate	2-3 °C/S
Preheat Temperature	150-200 °C
Preheat Time (t _s)	60-120 S
Liquid Temperature (T _L)	217 °C
Time maintained above T _L	60-90 S
Peak Temperature (T _p)	240±5 °C
Peak Time (t _p)	Max 20 S
Ramp-Down Rate	3-5 °C/S

- Reflow soldering should not be done more than twice.
- In soldering process, stress on the LEDs during heating should be avoided.
- After soldering, do not warp the circuit board.