

Single-/Dual-/Triple-Voltage μ P Supervisory Circuits with Independent Watchdog Output

MAX6730A–MAX6735A

General Description

The MAX6730A–MAX6735A single-/dual-/triple-voltage microprocessor (μ P) supervisors feature a watchdog timer and manual reset capability. The MAX6730A–MAX6735A offer factory-set reset thresholds for monitoring voltages from +0.9V to +5V and an adjustable reset input for monitoring voltages down to +0.63V. The combination of these features significantly improves system reliability and accuracy when compared to separate ICs or discrete components.

The active-low reset output asserts and remains asserted for the reset timeout period after all the monitored voltages exceed their respective thresholds. Multiple factory-set reset threshold combinations reduce the number of external components required. The MAX6730A/MAX6731A monitor a single fixed voltage, the MAX6732A/MAX6733A monitor two fixed voltages, and the MAX6734A/MAX6735A monitor two fixed voltages and one adjustable voltage. All devices are offered with six minimum reset timeout periods ranging from 1.1ms to 1120ms.

The MAX6730A–MAX6735A feature a watchdog timer with an independent watchdog output. The watchdog timer prevents system lockup during code execution errors. A watchdog startup delay of 54s after reset asserts allows system initialization during power-up. The watchdog operates in normal mode with a 1.68s delay after initialization. The MAX6730A/MAX6732A/MAX6734A provide an active-low, open-drain watchdog output. The MAX6731A/MAX6733A/MAX6735A provide an active-low, push-pull watchdog output.

Other features include a manual reset input (MAX6730A/MAX6731A/MAX6734A/MAX6735A) and push-pull reset output (MAX6731A/MAX6733A/MAX6735A) or open-drain reset output (MAX6730A/MAX6732A/MAX6734A). The MAX6730A–MAX6733A are offered in a tiny 6-pin SOT23 package. The MAX6734A/MAX6735A are offered in an 8-pin, space-saving SOT23 package. All devices are fully specified over the extended -40°C to +125°C temperature range.

Applications

- Multivoltage Systems
- Telecom/Networking Equipment
- Computers/Servers
- Portable/Battery-Operated Equipment
- Industrial Equipment
- Printer/Fax
- Set-Top Boxes

Typical Operating Circuit and Pin Configurations appear at end of data sheet.



Features

- ◆ **VCC1 (Primary Supply) Reset Threshold Voltages from +1.575V to +4.63V**
- ◆ **VCC2 (Secondary Supply) Reset Threshold Voltages from +0.79V to +3.08V**
- ◆ **Adjustable RSTIN Threshold for Monitoring Voltages Down to +0.63V (MAX6734A/MAX6735A Only)**
- ◆ **Six Reset Timeout Options**
- ◆ **Watchdog Timer with Independent Watchdog Output**
35s (min) Initial Watchdog Startup Period
1.12s (min) Normal Watchdog Timeout Period
- ◆ **Manual Reset Input (MAX6730A/MAX6731A/MAX6734A/MAX6735A)**
- ◆ **Guaranteed Reset Valid down to VCC1 or VCC2 = +0.8V**
- ◆ **Push-Pull $\overline{\text{RESET}}$ or Open-Drain $\overline{\text{RESET}}$ Output**
- ◆ **Immune to Short VCC Transients**
- ◆ **Low Supply Current: 14 μ A (typ) at +3.6V**
- ◆ **Small 6-Pin and 8-Pin SOT23 Packages**

Ordering Information

PART*	PIN-PACKAGE	PKG CODE
MAX6730AUT_D_-T	6 SOT23-6	U6-1
MAX6731AUT_D_-T	6 SOT23-6	U6-1
MAX6732AUT_D_-T	6 SOT23-6	U6-1
MAX6733AUT_D_-T	6 SOT23-6	U6-1
MAX6734AKA_D_-T	8 SOT23-8	K8S-3
MAX6735AKA_D_-T	8 SOT23-8	K8S-3

All devices specified over the -40°C to +125°C operating temperature range.

***Note:** Insert the threshold level suffixes for VCC1 and VCC2 (Table 1) after "UT" or "KA." For the MAX6730A/MAX6731A, insert only the VCC1 threshold suffix after the "UT." Insert the reset timeout delay (Table 2) after "D" to complete the part number. For example, the MAX6732AUTLTD3-T provides a VCC1 threshold of +4.625V, a VCC2 threshold of +3.075V, and a 210ms reset timeout period. Sample stock is generally held on standard versions only (see the Standard Versions table). Standard versions have an order increment requirement of 2500 pieces. Nonstandard versions have an order increment requirement of 10,000 pieces. Contact factory for availability. Devices are available in both leaded and lead-free packaging. Specify lead-free by replacing "T" with "+T" when ordering.

Single-/Dual-/Triple-Voltage μ P Supervisory Circuits with Independent Watchdog Output

ABSOLUTE MAXIMUM RATINGS

V_{CC1} , V_{CC2} , RSTIN, \overline{MR} , WDI to GND-0.3V to +6V
 \overline{RST} , \overline{WDO} to GND (open drain).....-0.3V to +6V
 \overline{RST} , \overline{WDO} to GND (push-pull).....-0.3V to (V_{CC1} + 0.3V)
 Input Current/Output Current (all pins)20mA
 Continuous Power Dissipation ($T_A = +70^\circ\text{C}$)
 6-Pin SOT23-6 (derate 8.7mW/ $^\circ\text{C}$ above +70 $^\circ\text{C}$)696mW
 8-Pin SOT23-8 (derate 8.9mW/ $^\circ\text{C}$ above +70 $^\circ\text{C}$)714mW

Operating Temperature Range-40 $^\circ\text{C}$ to +125 $^\circ\text{C}$
 Storage Temperature Range-65 $^\circ\text{C}$ to +150 $^\circ\text{C}$
 Junction Temperature+150 $^\circ\text{C}$
 Lead Temperature (soldering, 10s)+300 $^\circ\text{C}$

Stresses beyond those listed under "Absolute Maximum Ratings" may cause permanent damage to the device. These are stress ratings only, and functional operation of the device at these or any other conditions beyond those indicated in the operational sections of the specifications is not implied. Exposure to absolute maximum rating conditions for extended periods may affect device reliability.

ELECTRICAL CHARACTERISTICS

($V_{CC1} = V_{CC2} = +0.8\text{V}$ to +5.5V, $T_A = -40^\circ\text{C}$ to +125 $^\circ\text{C}$, unless otherwise noted. Typical values are at $T_A = +25^\circ\text{C}$.) (Note 1)

PARAMETER	SYMBOL	CONDITIONS	MIN	TYP	MAX	UNITS
Supply Voltage	V_{CC1} , V_{CC2}		0.8		5.5	V
Supply Current	I_{CC1}	$V_{CC1} < +5.5\text{V}$, all I/O connections open, outputs not asserted		15	39	μA
		$V_{CC1} < +3.6\text{V}$, all I/O connections open, outputs not asserted		10	28	
	I_{CC2}	$V_{CC2} < +3.6\text{V}$, all I/O connections open, outputs not asserted		4	11	
		$V_{CC2} < +2.75\text{V}$, all I/O connections open, outputs not asserted		3	9	
V_{CC1} Reset Threshold	V_{TH1}	L (falling)	4.500	4.625	4.750	V
		M (falling)	4.250	4.375	4.500	
		T (falling)	3.000	3.075	3.150	
		S (falling)	2.850	2.925	3.000	
		R (falling)	2.550	2.625	2.700	
		Z (falling)	2.250	2.313	2.375	
		Y (falling)	2.125	2.188	2.250	
		W (falling)	1.620	1.665	1.710	
V (falling)	1.530	1.575	1.620			

Single-/Dual-/Triple-Voltage μ P Supervisory Circuits with Independent Watchdog Output

MAX6730A-MAX6735A

ELECTRICAL CHARACTERISTICS (continued)

($V_{CC1} = V_{CC2} = +0.8V$ to $+5.5V$, $T_A = -40^\circ C$ to $+125^\circ C$, unless otherwise noted. Typical values are at $T_A = +25^\circ C$.) (Note 1)

PARAMETER	SYMBOL	CONDITIONS	MIN	TYP	MAX	UNITS
V _{CC2} Reset Threshold	V _{TH2}	T (falling)	3.000	3.075	3.150	V
		S (falling)	2.850	2.925	3.000	
		R (falling)	2.550	2.625	2.700	
		Z (falling)	2.250	2.313	2.375	
		Y (falling)	2.125	2.188	2.250	
		W (falling)	1.620	1.665	1.710	
		V (falling)	1.530	1.575	1.620	
		I (falling)	1.350	1.388	1.425	
		H (falling)	1.275	1.313	1.350	
		G (falling)	1.080	1.110	1.140	
		F (falling)	1.020	1.050	1.080	
		E (falling)	0.810	0.833	0.855	
D (falling)	0.765	0.788	0.810			
Reset Threshold Tempco				20		ppm/ $^\circ C$
Reset Threshold Hysteresis	V _{HYST}	Referenced to V _{TH} typical		0.5		%
V _{CC_} to \overline{RST} Output Delay	t _{RD}	V _{CC1} = (V _{TH1} + 100mV) to (V _{TH1} - 100mV) or V _{CC2} = (V _{TH2} + 75mV) to (V _{TH2} - 75mV)		45		μs
Reset Timeout Period	t _{RP}	D1	1.1	1.65	2.2	ms
		D2	8.8	13.2	17.6	
		D3	140	210	280	
		D5	280	420	560	
		D6	560	840	1120	
		D4	1120	1680	2240	
ADJUSTABLE RESET COMPARATOR INPUT (MAX6734A/MAX6735A)						
RSTIN Input Threshold	V _{RSTIN}		611	626.5	642	mV
RSTIN Input Current	I _{RSTIN}		-100		+100	nA
RSTIN Hysteresis				3		mV
RSTIN to Reset Output Delay	t _{RSTIND}	V _{RSTIN} to (V _{RSTIN} - 30mV)		22		μs
MANUAL RESET INPUT (MAX6730A/MAX6731A/MAX6734A/MAX6735A)						
\overline{MR} Input Threshold	V _{IL}			0.3 × V _{CC1}		V
	V _{IH}		0.7 × V _{CC1}			
\overline{MR} Minimum Pulse Width			1			μs
\overline{MR} Glitch Rejection				100		ns
\overline{MR} to Reset Output Delay	t _{MR}			200		ns
\overline{MR} Pullup Resistance			25	50	80	k Ω

Single-/Dual-/Triple-Voltage μ P Supervisory Circuits with Independent Watchdog Output

ELECTRICAL CHARACTERISTICS (continued)

($V_{CC1} = V_{CC2} = +0.8V$ to $+5.5V$, $T_A = -40^\circ C$ to $+125^\circ C$, unless otherwise noted. Typical values are at $T_A = +25^\circ C$.) (Note 1)

PARAMETER	SYMBOL	CONDITIONS	MIN	TYP	MAX	UNITS
WATCHDOG INPUT						
Watchdog Timeout Period	t _{WD-L}	First watchdog period after reset timeout period	35	54	72	s
	t _{WD-S}	Normal mode	1.12	1.68	2.24	
WDI Pulse Width	t _{WDI}	(Note 2)	50			ns
WDI Input Voltage	V _{IL}				0.3 × V _{CC1}	V
	V _{IH}		0.7 × V _{CC1}			
WDI Input Current	I _{WDI}	WDI = 0V or V _{CC1}	-1		+1	μA
RESET/WATCHDOG OUTPUT						
$\overline{RST}/\overline{WDO}$ Output Low Voltage (Push-Pull or Open Drain)	V _{OL}	V _{CC1} or V _{CC2} ≥ +0.8V, I _{SINK} = 1μA, output asserted			0.3	V
		V _{CC1} or V _{CC2} ≥ +1.0V, I _{SINK} = 50μA, output asserted			0.3	
		V _{CC1} or V _{CC2} ≥ +1.2V, I _{SINK} = 100μA, output asserted			0.3	
		V _{CC1} or V _{CC2} ≥ +2.7V, I _{SINK} = 1.2mA, output asserted			0.3	
		V _{CC1} or V _{CC2} ≥ +4.5V, I _{SINK} = 3.2mA, output asserted			0.4	
$\overline{RST}/\overline{WDO}$ Output High Voltage (Push-Pull Only)	V _{OH}	V _{CC1} ≥ +1.8V, I _{SOURCE} = 200μA, output not asserted	0.8 × V _{CC1}			V
		V _{CC1} ≥ +2.7V, I _{SOURCE} = 500μA, output not asserted	0.8 × V _{CC1}			
		V _{CC1} ≥ +4.5V, I _{SOURCE} = 800μA, output not asserted	0.8 × V _{CC1}			
$\overline{RST}/\overline{WDO}$ Output Open-Drain Leakage Current		Output not asserted			0.5	μA

Note 1: Devices tested at $T_A = +25^\circ C$. Overtemperature limits are guaranteed by design and not production tested.

Note 2: Parameter guaranteed by design.

Single-/Dual-/Triple-Voltage μ P Supervisory Circuits with Independent Watchdog Output

Typical Operating Characteristics

($V_{CC1} = +5V$, $V_{CC2} = +3.3V$, $T_A = +25^\circ C$, unless otherwise noted.)

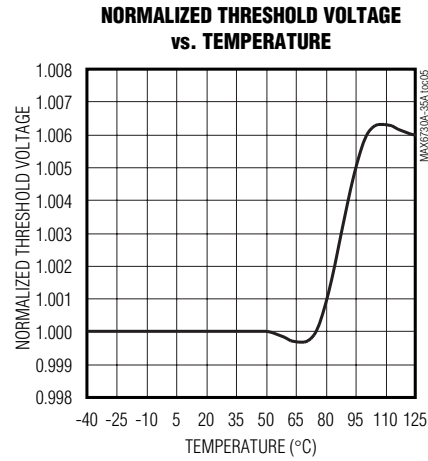
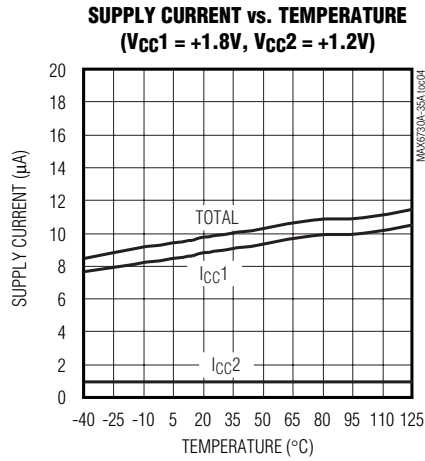
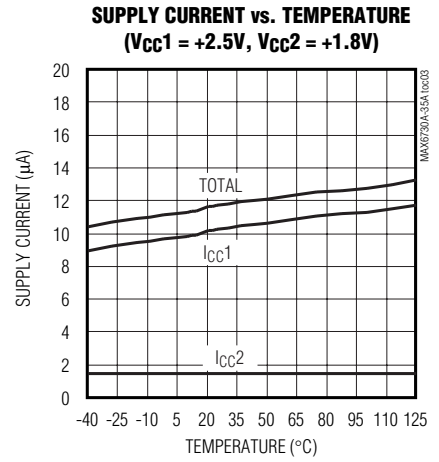
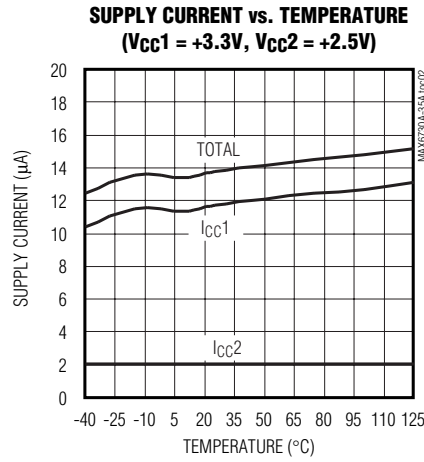
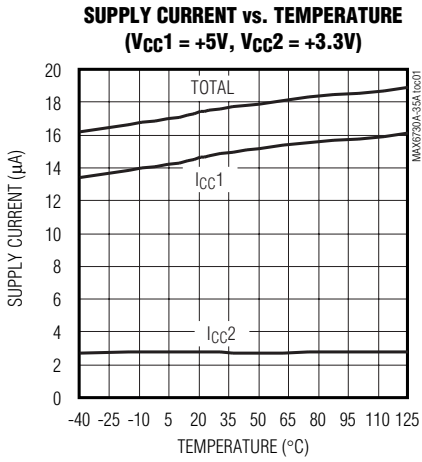

MAX6730A-MAX6735A

Single-/Dual-/Triple-Voltage μ P Supervisory Circuits with Independent Watchdog Output

Typical Operating Characteristics (continued)

($V_{CC1} = +5V$, $V_{CC2} = +3.3V$, $T_A = +25^\circ C$, unless otherwise noted.)

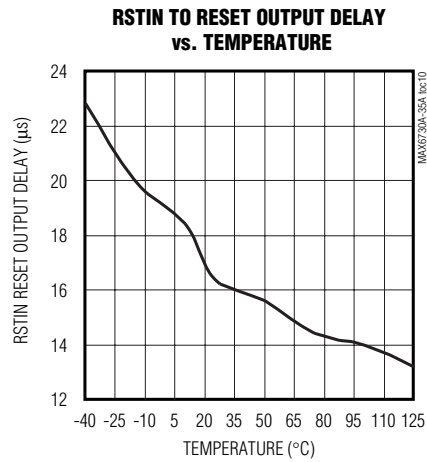
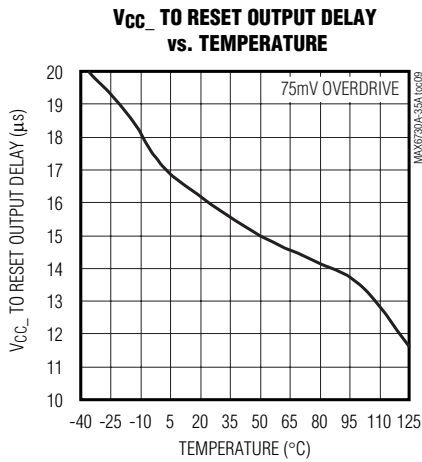
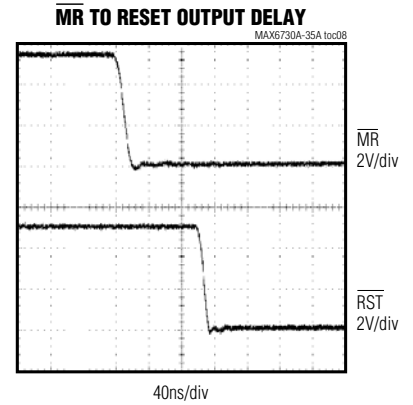
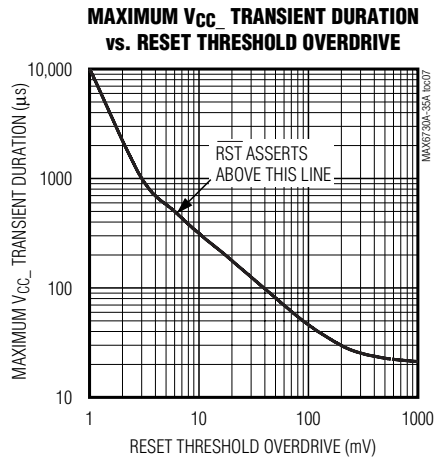
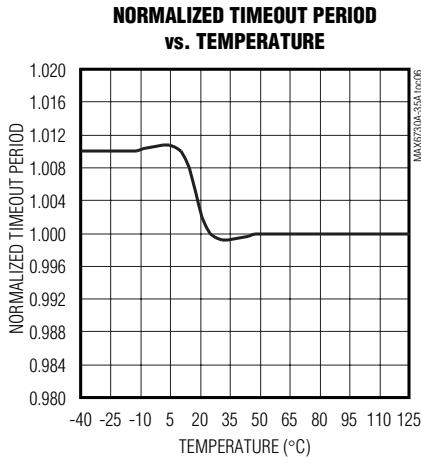

Single-/Dual-/Triple-Voltage μ P Supervisory Circuits with Independent Watchdog Output

Pin Description

MAX6730A-MAX6735A

PIN			NAME	FUNCTION
MAX6730A MAX6731A	MAX6732A MAX6733A	MAX6734A MAX6735A		
1	1	1	$\overline{\text{RST}}$	Active-Low Reset Output. The MAX6730A/MAX6732A/MAX6734A provide an open-drain output. The MAX6731A/MAX6733A/MAX6735A provide a push-pull output. $\overline{\text{RST}}$ asserts low when any of the following conditions occur: V_{CC1} or V_{CC2} drops below its preset threshold, RSTIN drops below its reset threshold, or $\overline{\text{MR}}$ is driven low. Open-drain versions require an external pullup resistor.
2	2	2	GND	Ground
3	3	4	$\overline{\text{WDO}}$	Active-Low Watchdog Output. The MAX6730A/MAX6732A/MAX6734A provide an open-drain $\overline{\text{WDO}}$ output. The MAX6731A/MAX6733A/MAX6735A provide a push-pull $\overline{\text{WDO}}$ output. $\overline{\text{WDO}}$ asserts low when no low-to-high or high-to-low transition occurs on WDI within the watchdog timeout period (t_{WD}) or if an undervoltage-lockout condition exists for V_{CC1} , V_{CC2} , or RSTIN . $\overline{\text{WDO}}$ deasserts without a timeout period when V_{CC1} , V_{CC2} , and RSTIN exceed their reset thresholds, or when the manual reset input is deasserted. Open-drain versions require an external pullup resistor.
4	—	5	$\overline{\text{MR}}$	Active-Low Manual Reset Input. Drive $\overline{\text{MR}}$ low to force a reset. $\overline{\text{RST}}$ remains asserted as long as $\overline{\text{MR}}$ is low and for the reset timeout period after $\overline{\text{MR}}$ releases high. $\overline{\text{MR}}$ has a 50k Ω pullup resistor to V_{CC1} ; leave $\overline{\text{MR}}$ open or connect to V_{CC1} if unused.
5	5	3	WDI	Watchdog Input. If WDI remains high or low for longer than the watchdog timeout period, the internal watchdog timer expires and the watchdog output asserts low. The internal watchdog timer clears whenever $\overline{\text{RST}}$ asserts or a rising or falling edge on WDI is detected. The watchdog has an initial watchdog timeout period (35s min) after each reset event and a short timeout period (1.12s min) after the first valid WDI transition. Floating WDI does not disable the watchdog timer function.
6	6	8	V_{CC1}	Primary Supply-Voltage Input. V_{CC1} provides power to the device when it is greater than V_{CC2} . V_{CC1} is the input to the primary reset threshold monitor.
—	4	6	V_{CC2}	Secondary Supply-Voltage Input. V_{CC2} provides power to the device when it is greater than V_{CC1} . V_{CC2} is the input to the secondary reset threshold monitor.
—	—	7	RSTIN	Undervoltage Reset Comparator Input. RSTIN provides a high-impedance comparator input for the adjustable reset monitor. $\overline{\text{RST}}$ asserts low if the voltage at RSTIN drops below the 626mV internal reference voltage. Connect a resistive voltage-divider to RSTIN to monitor voltages higher than 626mV. Connect RSTIN to V_{CC1} or V_{CC2} if unused.

Single-/Dual-/Triple-Voltage μ P Supervisory Circuits with Independent Watchdog Output

Table 1. Reset Voltage Threshold Suffix Guide**

PART NUMBER SUFFIX	V _{CC1} NOMINAL VOLTAGE THRESHOLD(V)	V _{CC2} NOMINAL VOLTAGE THRESHOLD (V)
LT	4.625	3.075
MS	4.375	2.925
MR	4.375	2.625
TZ	3.075	2.313
SY	2.925	2.188
RY	2.625	2.188
TW	3.075	1.665
SV	2.925	1.575
RV	2.625	1.575
TI	3.075	1.388
SH	2.925	1.313
RH	2.625	1.313
TG	3.075	1.110
SF	2.925	1.050
RF	2.625	1.050
TE	3.075	0.833
SD	2.925	0.788
RD	2.625	0.788
ZW	2.313	1.665
YV	2.188	1.575
ZI	2.313	1.388
YH	2.188	1.313
ZG	2.313	1.110
YF	2.188	1.050
ZE	2.313	0.833
YD	2.188	0.788
WI	1.665	1.388
VH	1.575	1.313
WG	1.665	1.110
VF	1.575	1.050
WE	1.665	0.833
VD	1.575	0.788

Standard versions are shown in bold and are available in a D3 timeout option only. Standard versions require 2500-piece order increments and are typically held in sample stock. There is a 10,000-piece order increment on nonstandard versions. **Other threshold voltages may be available; contact factory for availability.

Table 2. Reset Timeout Period Suffix Guide

TIMEOUT PERIOD SUFFIX	ACTIVE TIMEOUT PERIOD	
	MIN (ms)	MAX (ms)
D1	1.1	2.2
D2	8.8	17.6
D3	140	280
D5	280	560
D6	560	1120
D4	1120	2240

Detailed Description

Supply Voltages

The MAX6730A–MAX6735A microprocessor (μ P) supervisors maintain system integrity by alerting the μ P to fault conditions. The MAX6730A–MAX6735A monitor one to three supply voltages in μ P-based systems and assert an active-low reset output when any monitored supply voltage drops below its preset threshold. The output state remains valid for V_{CC1} or V_{CC2} greater than +0.8V.

Threshold Levels

The two-letter code in the Reset Voltage Threshold Suffix Guide (Table 1) indicates the threshold level combinations for V_{CC1} and V_{CC2}.

Reset Output

The MAX6730A–MAX6735A feature an active-low reset output (\overline{RST}). \overline{RST} asserts when the voltage at either V_{CC1} or V_{CC2} falls below the voltage threshold level, V_{RSTIN} drops below its threshold, or \overline{MR} is driven low (Figure 1). \overline{RST} remains low for the reset timeout period (Table 2) after V_{CC1}, V_{CC2}, and RSTIN increase above their respective thresholds and after \overline{MR} releases high. Whenever V_{CC1}, V_{CC2}, or RSTIN go below the reset threshold before the end of the reset timeout period, the internal timer restarts. The MAX6730A/MAX6732A/MAX6734A provide an open-drain \overline{RST} output, and the MAX6731A/MAX6733A/MAX6735A provide a push-pull \overline{RST} output.

Single-/Dual-/Triple-Voltage μ P Supervisory Circuits with Independent Watchdog Output

MAX6730A-MAX6735A

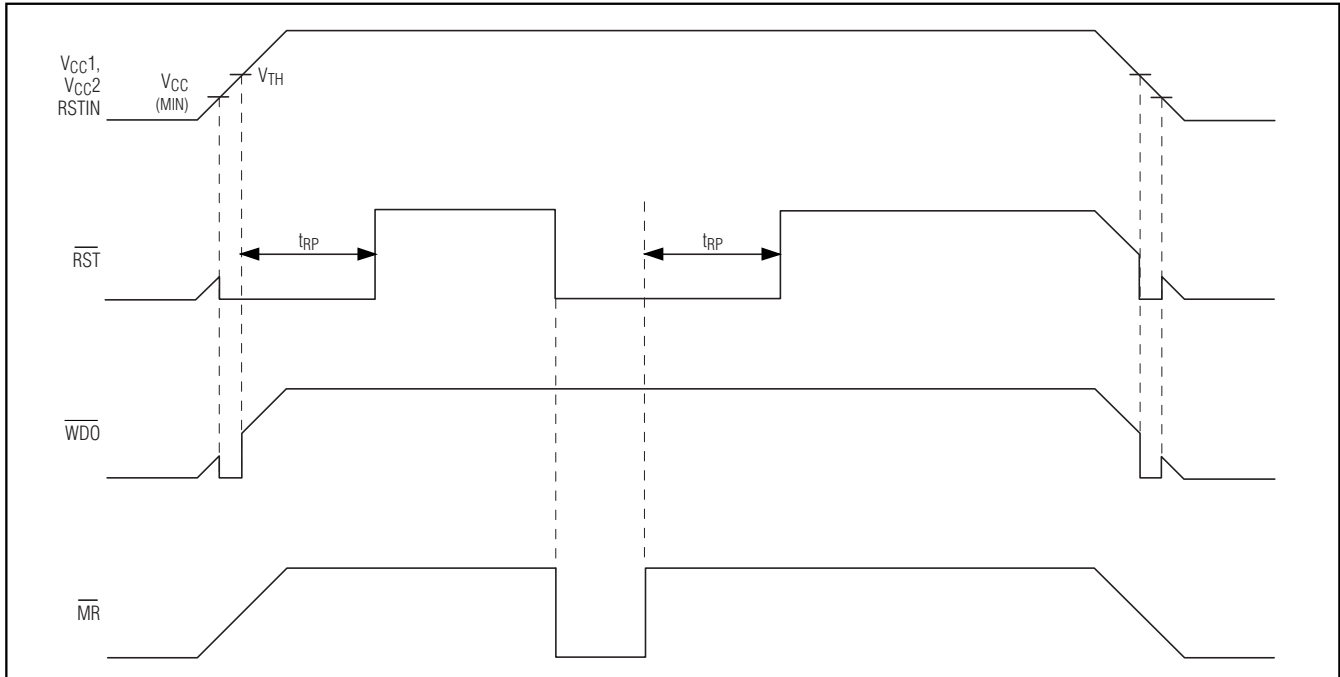

Figure 1. \overline{RST} , \overline{WDO} , and \overline{MR} Timing Diagram

Manual Reset Input

Many μ P-based products require manual reset capability, allowing the operator, a test technician, or external logic circuitry to initiate a reset. A logic-low on \overline{MR} asserts the reset output, clears the watchdog timer, and deasserts the watchdog output. Reset remains asserted while \overline{MR} is low and for the reset timeout period (t_{RP}) after \overline{MR} returns high. An internal 50k Ω pullup resistor allows \overline{MR} to be left open if unused. Drive \overline{MR} with CMOS-logic levels or with open-drain/collector outputs. Connect a normally open momentary switch from \overline{MR} to GND to create a manual reset function; external debounce circuitry is not required. Connect a 0.1 μ F capacitor from \overline{MR} to GND to provide additional noise immunity when driving \overline{MR} over long cables or if the device is used in a noisy environment.

Adjustable Input Voltage (RSTIN)

The MAX6734A/MAX6735A provide an additional high-impedance comparator input with a 626mV threshold to monitor a third supply voltage. To monitor a voltage higher than 626mV, connect a resistive divider to the circuit as shown in Figure 2 to establish an externally controlled threshold voltage, V_{EXT_TH} .

$$V_{EXT_TH} = 626\text{mV} \times \frac{(R1 + R2)}{R2}$$

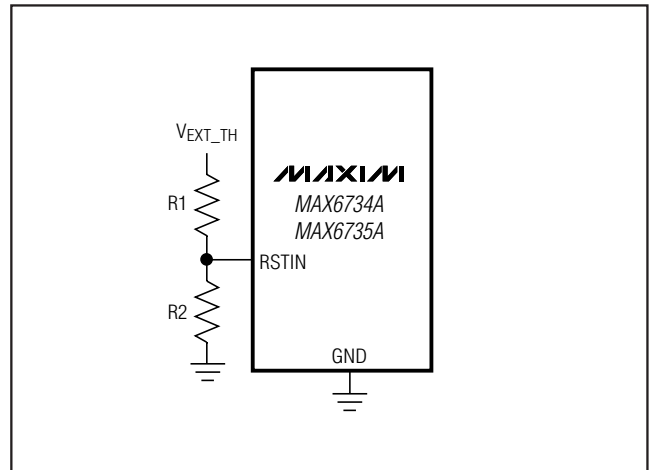

Figure 2. Monitoring a Third Voltage

Single-/Dual-/Triple-Voltage μ P Supervisory Circuits with Independent Watchdog Output

The RSTIN comparator derives power from V_{CC1} , and the input voltage must remain less than or equal to V_{CC1} . Low leakage current at RSTIN allows the use of large-valued resistors, resulting in reduced power consumption of the system.

Watchdog

The watchdog feature monitors μ P activity through the watchdog input (WDI). A rising or falling edge on WDI within the watchdog timeout period (t_{WD}) indicates normal μ P operation. \overline{WDO} asserts low if WDI remains high or low for longer than the watchdog timeout period. Floating WDI does not disable the watchdog timer.

The MAX6730A-MAX6735A include a dual-mode watchdog timer to monitor μ P activity. The flexible timeout architecture provides a long-period initial watchdog mode, allowing complicated systems to complete lengthy boots, and a short-period normal watchdog mode, allowing the supervisor to provide quick alerts when processor activity fails. After each reset event (V_{CC} power-up, brownout, or manual reset), there is a long initial watchdog period of 35s (min). The long watchdog period mode provides an extended time for the system to power up and fully initialize all μ P and system components before assuming responsibility for routine watchdog updates.

The usual watchdog timeout period (1.12s min) begins after the initial watchdog timeout period (t_{WD-L}) expires or after the first transition on WDI (Figure 3). During normal operating mode, the supervisor asserts the \overline{WDO} output if the μ P does not update the WDI with a valid transition (high to low or low to high) within the standard timeout period (t_{WD-S}) (1.12s min).

Connect \overline{MR} to \overline{WDO} to force a system reset in the event that no rising or falling edge is detected at WDI within the watchdog timeout period. \overline{WDO} asserts low when no edge is detected by WDI, the \overline{RST} output asserts low, the watchdog counter immediately clears, and \overline{WDO} returns high. The watchdog counter restarts, using the long watchdog period, when the reset timeout period ends (Figure 4).

Ensuring a Valid Reset Output Down to $V_{CC} = 0V$

The MAX6730A-MAX6735A guarantee proper operation down to $V_{CC} = +0.8V$. In applications that require valid reset levels down to $V_{CC} = 0V$, use a 100k Ω pull-down resistor from \overline{RST} to GND. The resistor value used is not critical, but it must be large enough not to load the reset output when V_{CC} is above the reset threshold. For most applications, 100k Ω is adequate. Note that this configuration does not work for the open-drain outputs of MAX6730A/MAX6732A/MAX6734A.

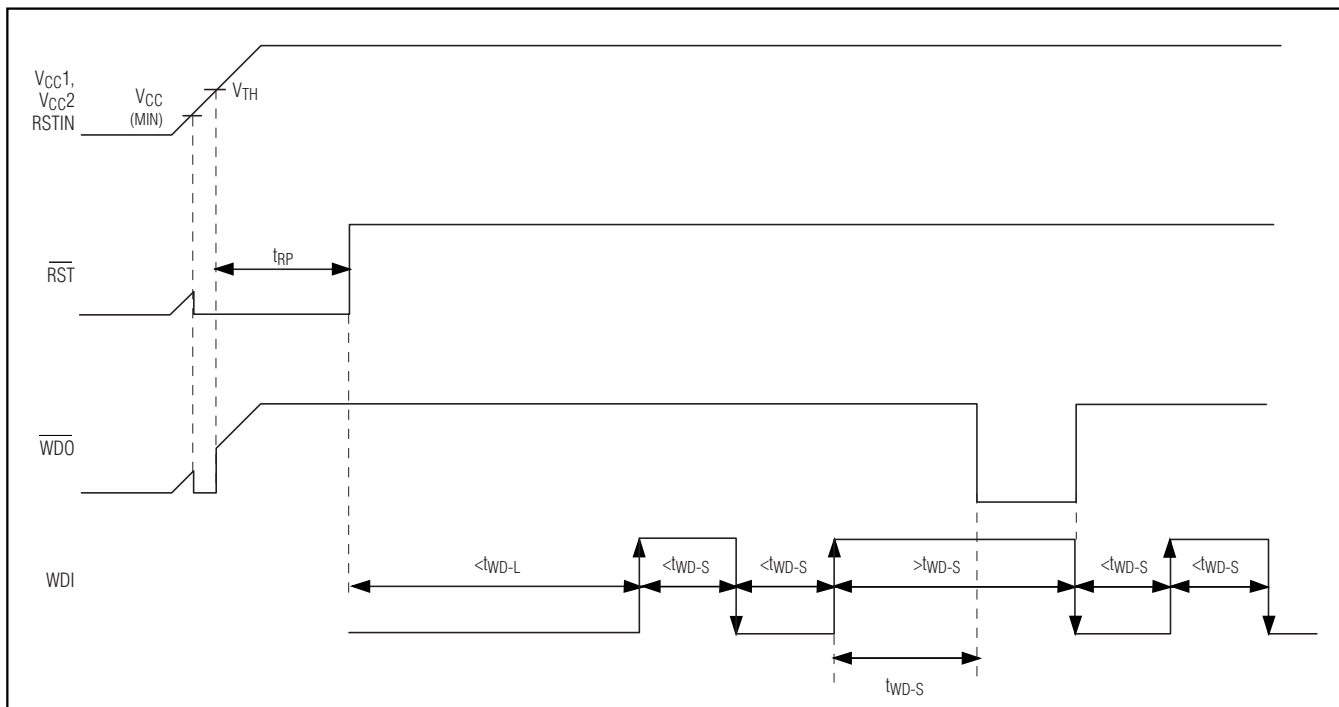

Figure 3. Watchdog Input/Output Timing Diagram (\overline{MR} and \overline{WDO} Not Connected)

Single-/Dual-/Triple-Voltage μ P Supervisory Circuits with Independent Watchdog Output

MAX6730A-MAX6735A

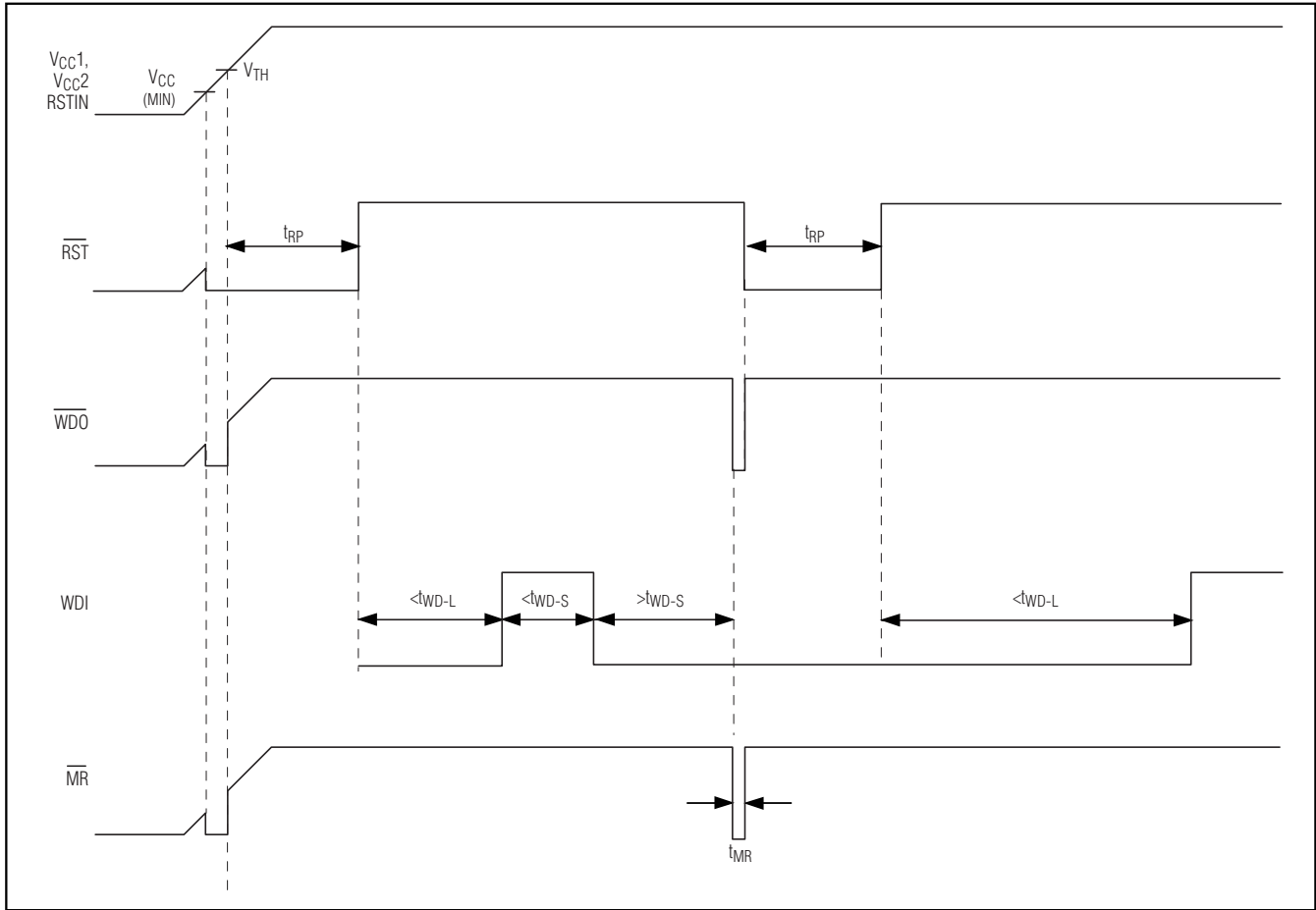

Figure 4. Watchdog Input/Output Timing Diagram (\overline{MR} and \overline{WDO} Connected)

Applications Information

Interfacing to μ Ps with Bidirectional Reset Pins

Microprocessors with bidirectional reset pins can interface directly with the open-drain \overline{RST} output options. However, conditions might occur in which the push-pull output versions experience logic contention with the bidirectional reset pin of the μ P. Connect a 10k Ω resistor between \overline{RST} and the μ P's reset I/O port to prevent logic contention (Figure 5).

Falling VCC Transients

The MAX6730A-MAX6735A μ P supervisors are relatively immune to short-duration falling VCC_ transients (glitches). Small glitches on VCC_ are ignored by the MAX6730A-MAX6735A, preventing undesirable reset pulses to the μ P. The *Typical Operating Characteristics* show Maximum VCC_ Transient Duration vs. Reset

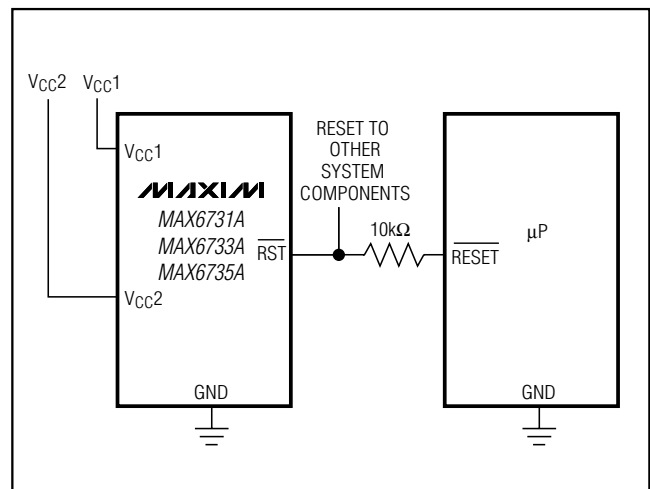

Figure 5. Interfacing to μ Ps with Bidirectional Reset I/O

Single-/Dual-/Triple-Voltage μ P Supervisory Circuits with Independent Watchdog Output

Threshold Overdrive graph, for which reset pulses are not generated. The graph was produced using falling $V_{CC_}$ pulses, starting above V_{TH} and ending below the reset threshold by the magnitude indicated (reset threshold overdrive). The graph shows the maximum pulse width that a falling V_{CC} transient typically might have without causing a reset pulse to be issued. As the amplitude of the transient increases (i.e., goes further below the reset threshold), the maximum allowable pulse width decreases. A $0.1\mu\text{F}$ bypass capacitor mounted close to $V_{CC_}$ provides additional transient immunity.

Watchdog Software Considerations

Setting and resetting the watchdog input at different points in the program rather than “pulsing” the watchdog input high-low-high or low-high-low helps the watchdog timer closely monitor software execution. This technique avoids a “stuck” loop, in which the watchdog timer continues to be reset within the loop, preventing the watchdog from timing out. Figure 6 shows an example flow diagram in which the I/O driving the watchdog input is set high at the beginning of the program, set low at the beginning of every subroutine or loop, and then set high again when the program returns to the beginning. If the program “hangs” in any subroutine, the I/O continually asserts low (or high), and the watchdog timer expires, issuing a reset or interrupt.

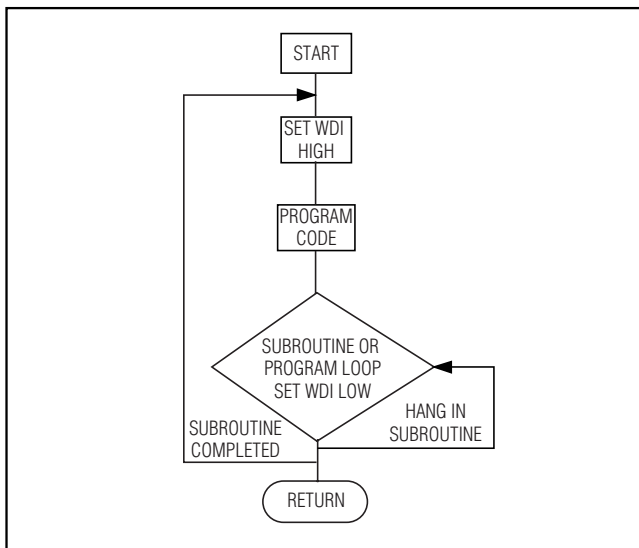
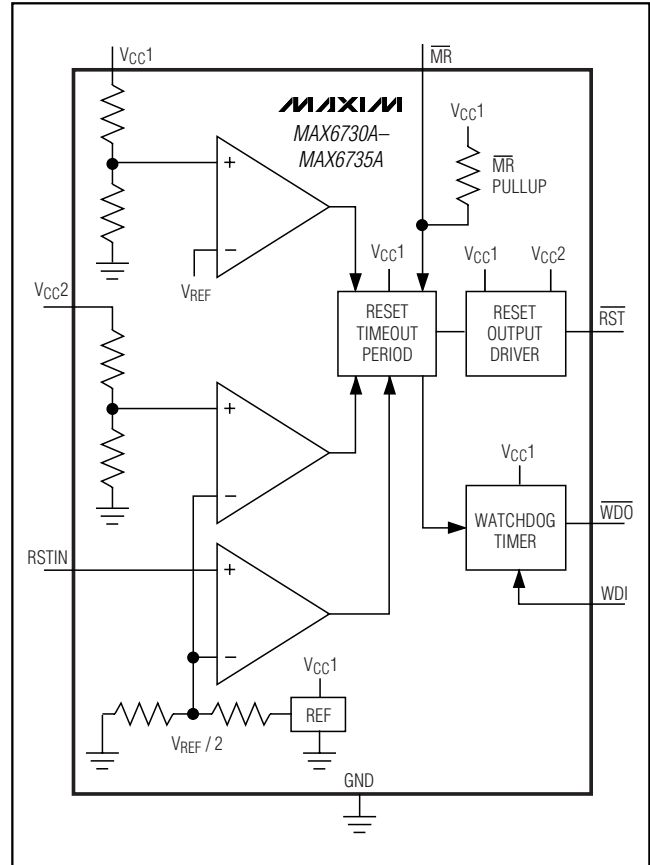

Figure 6. Watchdog Flow Diagram

Functional Diagram



Single-/Dual-/Triple-Voltage μ P Supervisory Circuits with Independent Watchdog Output

Standard Versions

MAX6730A-MAX6735A

PART	TOP MARK
MAX6730A UTLD3-T	+ACIX
MAX6730AUTSD3-T	+ACJA
MAX6730AUTRD3-T	+ACIY
MAX6730AUTZD3-T	+ACJF
MAX6730AUTVD3-T	+ACJC
MAX6731A UTLD3-T	+ACJG
MAX6731AUTTD3-T	+ACJJ
MAX6731AUTSD3-T	+ACJI
MAX6731AUTRD3-T	+ACJH
MAX6731AUTZD3-T	+ACJL
MAX6731AUTVD3-T	+ACJK
MAX6732A UTLTD3-T	+ACHU
MAX6732AUTSYD3-T	+ACHZ
MAX6732AUTSVD3-T	+ACHY
MAX6732AUTRVD3-T	+ACHV
MAX6732AUTSHD3-T	+ACHX
MAX6732AUTTG3-T	+ACIA
MAX6732AUTSDD3-T	+ACHW
MAX6732AUTZWD3-T	+ACIH
MAX6732AUTYHD3-T	+ACIF
MAX6732AUTZGD3-T	+ACIG
MAX6732AUTYDD3-T	+ACIE
MAX6732AUTVHD3-T	+ACIC
MAX6732AUTWGD3-T	+ACID
MAX6732AUTVDD3-T	+ACIB
MAX6733A UTLTD3-T	+ACII
MAX6733AUTSYD3-T	+ACIN
MAX6733AUTSVD3-T	+ACIM
MAX6733AUTRVD3-T	+ACIJ
MAX6733AUTSHD3-T	+ACIL
MAX6733AUTTG3-T	+ACIO
MAX6733AUTSDD3-T	+ACIK
MAX6733AUTZWD3-T	+ACIW
MAX6733AUTYHD3-T	+ACIU

PART	TOP MARK
MAX6733AUTZGD3-T	+ACIV
MAX6733AUTYDD3-T	+ACIT
MAX6733AUTVHD3-T	+ACIR
MAX6733AUTWGD3-T	+ACIS
MAX6733AUTVDD3-T	+ACIQ
MAX6734A KALTD3-T	+AENS
MAX6734AKASYD3-T	+AENZ
MAX6734AKASVD3-T	+AENY
MAX6734AKARVD3-T	+AENU
MAX6734AKASHD3-T	+AENX
MAX6734AKATGD3-T	+AEOA
MAX6734AKASDD3-T	+AENV
MAX6734AKAZWD3-T	+AEOI
MAX6734AKAYHD3-T	+AEOG
MAX6734AKAZGD3-T	+AEOH
MAX6734AKAYDD3-T	+AEOF
MAX6734AKAVHD3-T	+AEOD
MAX6734AKAWGD3-T	+AEOE
MAX6734AKAVDD3-T	+AEOC
MAX6735A KALTD3-T	+AEOJ
MAX6735AKASYD3-T	+AEOO
MAX6735AKASVD3-T	+AEON
MAX6735AKARVD3-T	+AEOK
MAX6735AKASHD3-T	+AEOM
MAX6735AKATGD3-T	+AEOP
MAX6735AKASDD3-T	+AEOL
MAX6735AKAZWD3-T	+AEOX
MAX6735AKAZID3-T	+AEOW
MAX6735AKAYHD3-T	+AEOU
MAX6735AKAZGD3-T	+AEOV
MAX6735AKAYDD3-T	+AEOT
MAX6735AKAVHD3-T	+AEOR
MAX6735AKAWGD3-T	+AEOS
MAX6735AKAVDD3-T	+AEOQ

Note: Sample stock is generally held on standard versions only. Standard versions have an order increment requirement of 2500 pieces. Nonstandard versions have an order increment requirement of 10,000 pieces. Contact factory for availability of nonstandard versions.

Single-/Dual-/Triple-Voltage μ P Supervisory Circuits with Independent Watchdog Output

Pin Configurations

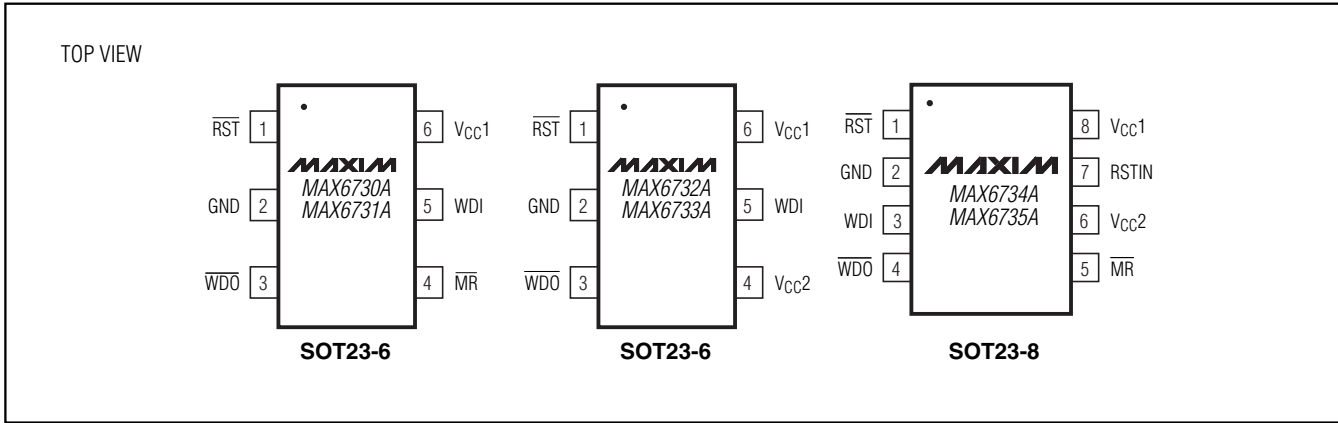

Typical Operating Circuit

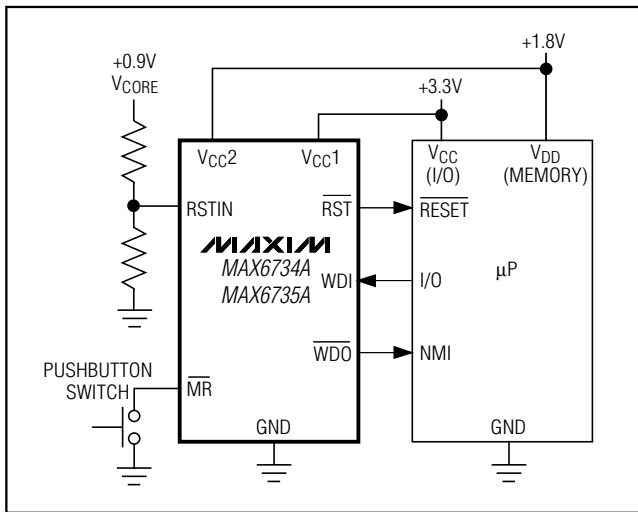

Chip Information

TRANSISTOR COUNT: 1073
PROCESS: BiCMOS

Selector Guide

PART NUMBER	VOLTAGE MONITORS	$\overline{\text{RST}}$ OUTPUT	MANUAL RESET	WATCHDOG INPUT	WATCHDOG OUTPUT
MAX6730A	1	Open Drain	√	√	Open Drain
MAX6731A	1	Push-Pull	√	√	Push-Pull
MAX6732A	2	Open Drain	—	√	Open Drain
MAX6733A	2	Push-Pull	—	√	Push-Pull
MAX6734A	3	Open Drain	√	√	Open Drain
MAX6735A	3	Push-Pull	√	√	Push-Pull

Single-/Dual-/Triple-Voltage μ P Supervisory Circuits with Independent Watchdog Output

Package Information

(The package drawing(s) in this data sheet may not reflect the most current specifications. For the latest package outline information go to www.maxim-ic.com/packages.)

MAX6730A-MAX6735A

6LSOT-EPS

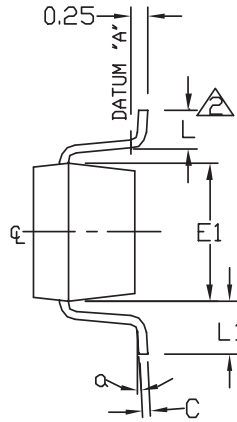
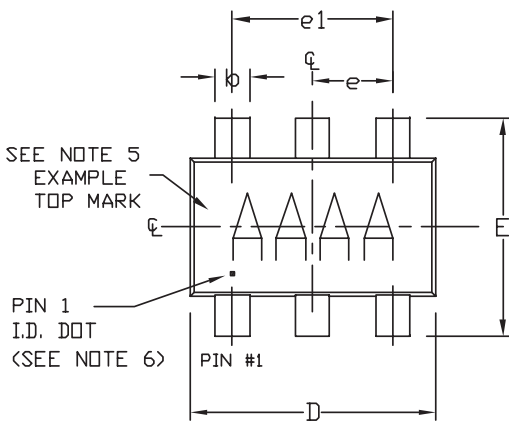

SYMBOL	MIN	MAX
A	0.90	1.45
A1	0.00	0.15
A2	0.90	1.30
b	0.35	0.50
C	0.08	0.20
D	2.80	3.00
E	2.60	3.00
E1	1.50	1.75
L	0.35	0.60
L1	0.60	REF.
e1	1.90	BSC.
e	0.95	BSC.
a	0°	10°

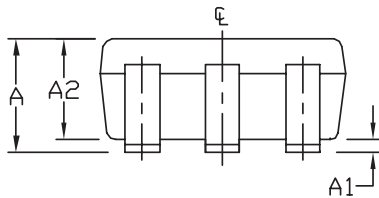

NOTES:

1. ALL DIMENSIONS ARE IN MILLIMETERS.
2. FOOT LENGTH MEASURED AT INTERCEPT POINT BETWEEN DATUM A & LEAD SURFACE.
3. PACKAGE OUTLINE EXCLUSIVE OF MOLD FLASH & METAL BURR. MOLD FLASH, PROTRUSION OR METAL BURR SHOULD NOT EXCEED 0.25 MM.
4. PACKAGE OUTLINE INCLUSIVE OF SOLDER PLATING.
5. PIN 1 IS LOWER LEFT PIN WHEN READING TOP MARK FROM LEFT TO RIGHT. (SEE EXAMPLE TOP MARK)
6. PIN 1 I.D. DOT IS 0.3 MM ϕ MIN. LOCATED ABOVE PIN 1.
7. MEETS JEDEC MO17B, VARIATION AB.
8. SOLDER THICKNESS MEASURED AT FLAT SECTION OF LEAD BETWEEN 0.08mm AND 0.15mm FROM LEAD TIP.
9. LEAD TO BE COPLANAR WITHIN 0.1 MM.

-DRAWING NOT TO SCALE-

TITLE PACKAGE OUTLINE, SOT 6L BODY		
APPROVAL	DOCUMENT CONTROL NO. 21-0058	REV. G 1/1

Single-/Dual-/Triple-Voltage μ P Supervisory Circuits with Independent Watchdog Output

Package Information (continued)

(The package drawing(s) in this data sheet may not reflect the most current specifications. For the latest package outline information go to www.maxim-ic.com/packages.)

SOT23, 8L .EPS

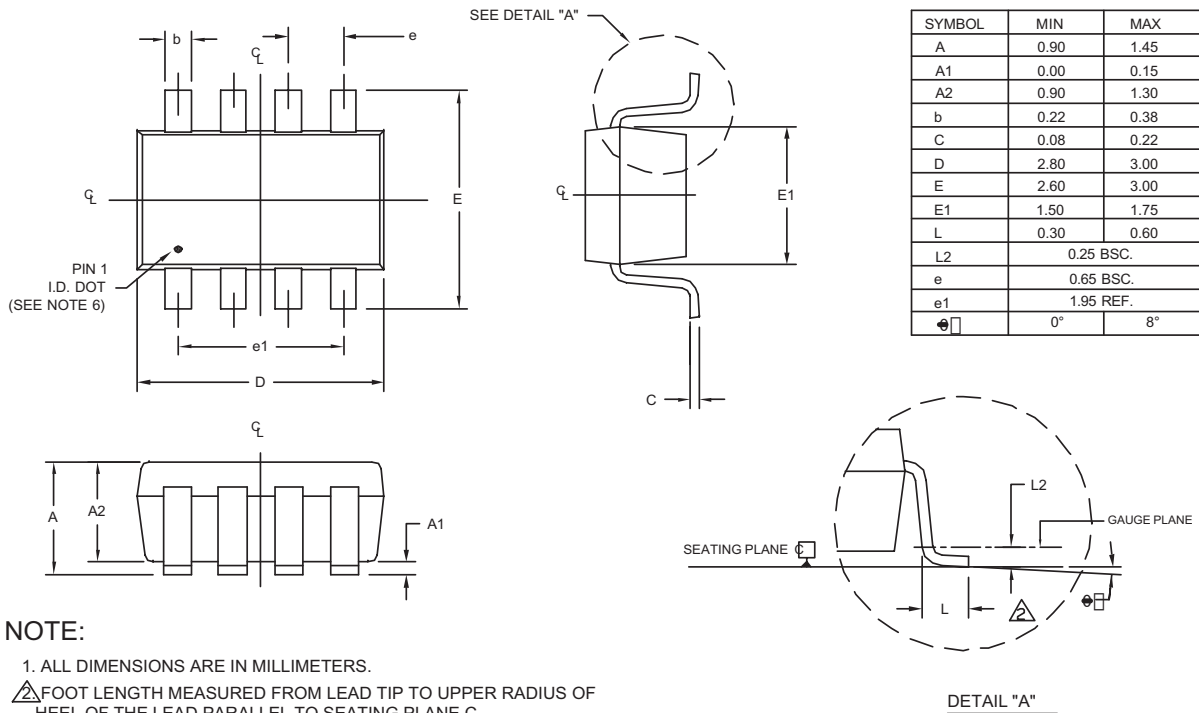

NOTE:

1. ALL DIMENSIONS ARE IN MILLIMETERS.
2. \triangle FOOT LENGTH MEASURED FROM LEAD TIP TO UPPER RADIUS OF HEEL OF THE LEAD PARALLEL TO SEATING PLANE C.
3. PACKAGE OUTLINE EXCLUSIVE OF MOLD FLASH & METAL BURR.
4. PACKAGE OUTLINE INCLUSIVE OF SOLDER PLATING.
5. COPLANARITY 4 MILS. MAX.
6. PIN 1 I.D. DOT IS 0.3 MM ϕ MIN. LOCATED ABOVE PIN 1.
7. SOLDER THICKNESS MEASURED AT FLAT SECTION OF LEAD BETWEEN 0.08mm AND 0.15mm FROM LEAD TIP.
8. MEETS JEDEC MO178 VARIATION BA.

DALLAS SEMICONDUCTOR **MAXIM**

PROPRIETARY INFORMATION

TITLE: PACKAGE OUTLINE, SOT-23, 8L BODY

APPROVAL:	DOCUMENT CONTROL NO. 21-0078	REV. E	1/1
-----------	------------------------------	--------	-----

Maxim cannot assume responsibility for use of any circuitry other than circuitry entirely embodied in a Maxim product. No circuit patent licenses are implied. Maxim reserves the right to change the circuitry and specifications without notice at any time.