

MAXIM

+12V, 30mA Flash Memory Programming Supply

MAX662A

General Description

The MAX662A is a regulated +12V, 30mA-output, charge-pump DC-DC converter. It provides the necessary +12V $\pm 5\%$ output to program byte-wide flash memories, and requires no inductors to deliver a guaranteed 30mA output from inputs as low as 4.75V. It fits into less than 0.1in² of board space. The MAX662A is a pin-compatible upgrade to the MAX662, and is recommended for new designs. The MAX662A offers lower quiescent and shutdown currents, and guarantees the output current over all temperature ranges.

The MAX662A is the first charge-pump boost converter to provide a regulated +12V output. It requires only a few inexpensive capacitors, and the entire circuit is completely surface-mountable.

A logic-controlled shutdown pin that interfaces directly with microprocessors reduces the supply current to only 0.5 μ A. The MAX662A comes in 8-pin narrow SO and DIP packages.

For higher-current flash memory programming solutions, refer to the data sheets for the MAX734 (120mA output current, guaranteed) and MAX732 (200mA output current, guaranteed) PWM, switch-mode DC-DC converters. Or, refer to the MAX761 data sheet for a 150mA, PFM switch-mode DC-DC converter that operates from inputs as low as 2V.

Applications

- +12V Flash Memory Programming Supplies
- Compact +12V Op-Amp Supplies
- Switching MOSFETs in Low-Voltage Systems
- Dual-Output +12V and +20V Supplies

Typical Operating Circuit

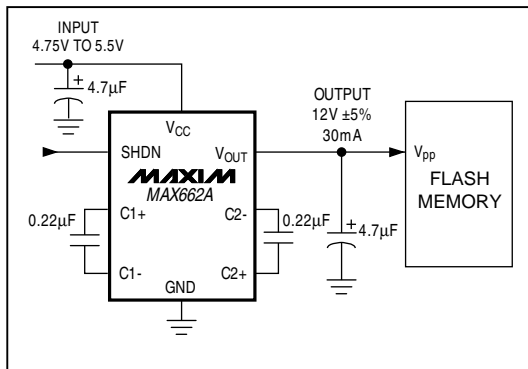

Features

- ◆ Regulated +12V $\pm 5\%$ Output Voltage
- ◆ 4.5V to 5.5V Supply Voltage Range
- ◆ Fits in 0.1in²
- ◆ Guaranteed 30mA Output
- ◆ No Inductor—Uses Only 4 Capacitors
- ◆ 185 μ A Quiescent Current
- ◆ Logic-Controlled 0.5 μ A Shutdown
- ◆ 8-Pin Narrow SO and DIP Packages

Ordering Information

PART	TEMP. RANGE	PIN-PACKAGE
MAX662ACPA	0°C to +70°C	8 Plastic DIP
MAX662ACSA	0°C to +70°C	8 SO
MAX662AC/D	0°C to +70°C	Dice*
MAX662AEPA	-40°C to +85°C	8 Plastic DIP
MAX662AESA	-40°C to +85°C	8 SO
MAX662AMJA	-55°C to +125°C	8 CERDIP**

* Dice are tested at $T_A = +25^\circ\text{C}$.

** Contact factory for availability and processing to MIL-STD-883.

Pin Configuration

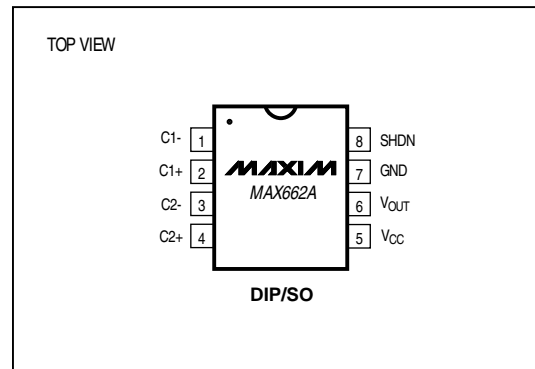

+12V, 30mA Flash Memory Programming Supply

ABSOLUTE MAXIMUM RATINGS

V _{CC} to GND-0.3V to 6V
SHDN-0.3V to (V _{CC} + 0.3V)
I _{OUT} Continuous50mA
Continuous Power Dissipation (T _A = +70°C)	
Plastic DIP (derate 9.09mW/°C above +70°C)727mW
SO (derate 5.88mW/°C above +70°C)471mW
CERDIP (derate 8.00mW/°C above +70°C)640mW

Operating Temperature Ranges

MAX662AC_A0°C to +70°C
MAX662AE_A-40°C to +85°C
MAX662AMJA-55°C to +125°C
Storage Temperature Range-65°C to +160°C
Lead Temperature (soldering, 10sec)+300°C

Stresses beyond those listed under "Absolute Maximum Ratings" may cause permanent damage to the device. These are stress ratings only, and functional operation of the device at these or any other conditions beyond those indicated in the operational sections of the specifications is not implied. Exposure to absolute maximum rating conditions for extended periods may affect device reliability.

ELECTRICAL CHARACTERISTICS

(Circuit of Figure 3a, V_{CC} = 4.5V to 5.5V, T_A = T_{MIN} to T_{MAX}, unless otherwise noted.)

PARAMETER	SYMBOL	CONDITIONS	MIN	TYP	MAX	UNITS
Output Voltage	V _{OUT}	MAX662AC/E 0mA ≤ I _{OUT} ≤ 30mA, V _{CC} = 4.75V to 5.5V	11.4	12	12.6	V
			11.4	12	12.6	
		MAX662AM 0mA ≤ I _{OUT} ≤ 24mA, V _{CC} = 4.75V to 5.5V	11.4	12	12.6	
			11.4	12	12.6	
Supply Current	I _{CC}	No load, V _{SHDN} = 0V		185	500	μA
Shutdown Current		No load, V _{SHDN} = V _{CC}		0.5	10	μA
Oscillator Frequency	f _{OSC}	V _{CC} = 5V, I _{OUT} = 30mA		500		kHz
Power Efficiency		V _{CC} = 5V, I _{OUT} = 30mA		76		%
V _{CC} -to-V _{OUT} Switch Impedance	R _{SW}	V _{CC} = V _{SHDN} = 5V, I _{OUT} = 30mA	MAX662AC/E	1	2	kΩ
			MAX662AM	1	2.5	
Shutdown Input Threshold	V _{IH}		2.4			V
	V _{IL}				0.4	
SHDN Pin Current		V _{CC} = 5V, V _{SHDN} = 0V	-50	-15	-5	μA
		V _{CC} = V _{SHDN} = 5V		0		

Typical Operating Characteristics

(Circuit of Figure 3a, T_A = +25°C, unless otherwise noted.)

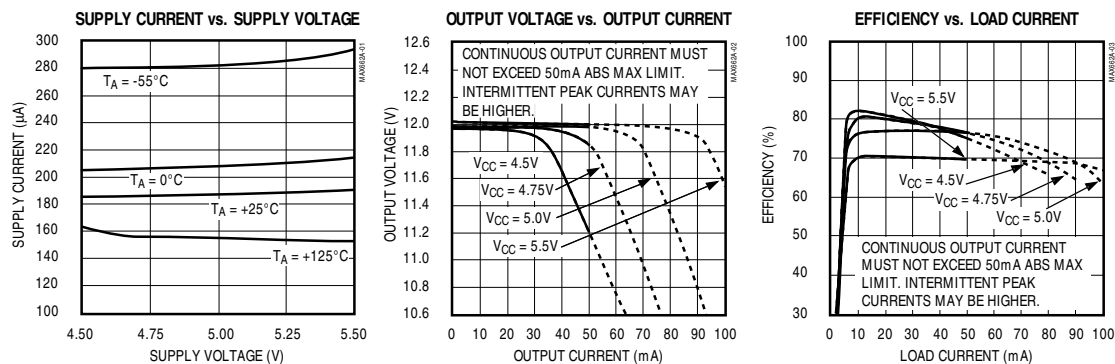

+12V, 30mA Flash Memory Programming Supply

MAX662A

Typical Operating Characteristics (continued)

(Circuit of Figure 3a, $T_A = +25^\circ\text{C}$, unless otherwise noted.)

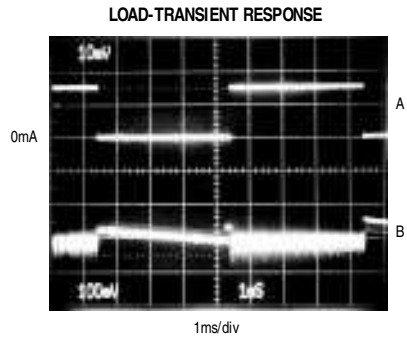

A: OUTPUT CURRENT, 20mA/div, $I_{OUT} = 0\text{mA}$ to 30mA
 B: OUTPUT VOLTAGE RIPPLE, 100mV/div, $V_{CC} = 5.0\text{V}$

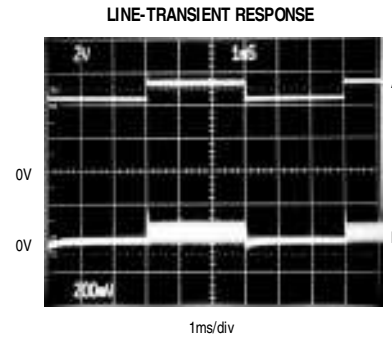

A: SUPPLY VOLTAGE 2V/div, $V_{CC} = 4.5\text{V}$ to 5.5V , $I_{OUT} = 30\text{mA}$
 B: OUTPUT VOLTAGE RIPPLE, 200mV/div

Pin Description

PIN	NAME	FUNCTION
1	C1-	Negative terminal for the first charge-pump capacitor
2	C1+	Positive terminal for the first charge-pump capacitor
3	C2-	Negative terminal for the second charge-pump capacitor
4	C2+	Positive terminal for the second charge-pump capacitor
5	VCC	Supply Voltage
6	VOUT	+12V Output Voltage. $V_{OUT} = V_{CC}$ when in shutdown mode.
7	GND	Ground
8	SHDN	Active-high CMOS-logic level Shutdown Input. SHDN is internally pulled up to V_{CC} . Connect to GND for normal operation. In shutdown mode, the charge pumps are turned off and $V_{OUT} = V_{CC}$.

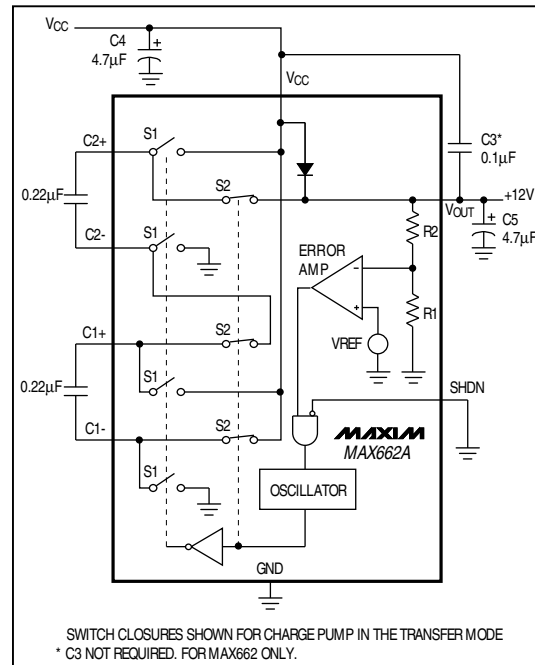

Figure 1. Block Diagram

+12V, 30mA Flash Memory Programming Supply

Detailed Description

Operating Principle

The MAX662A provides a regulated 12V output voltage at 30mA from a 5V \pm 5% power supply, making it ideal for flash EEPROM programming applications. It uses internal charge pumps and external capacitors to generate +12V, eliminating inductors. Regulation is provided by a pulse-skipping scheme that monitors the output voltage level and turns on the charge pumps when the output voltage begins to droop.

Figure 1 shows a simplified block diagram of the MAX662A. When the S1 switches are closed and the S2 switches are open, capacitors C1 and C2 are charged up to V_{CC} . The S1 switches are then opened and the S2 switches are closed so that capacitors C1 and C2 are connected in series between V_{CC} and V_{OUT} . This performs a voltage tripling function. A pulse-skipping feedback scheme adjusts the output voltage to 12V \pm 5%. The efficiency of the MAX662A with $V_{CC} = 5V$ and $I_{OUT} = 30mA$ is typically 76%. See the Efficiency vs. Load Current graph in the *Typical Operating Characteristics*.

During one oscillator cycle, energy is transferred from the charge-pump capacitors to the output filter capacitor and the load. The number of cycles within a given time frame increases as the load current increases or as the input supply voltage decreases. In the limiting case, the charge pumps operate continuously, and the oscillator frequency is nominally 500kHz.

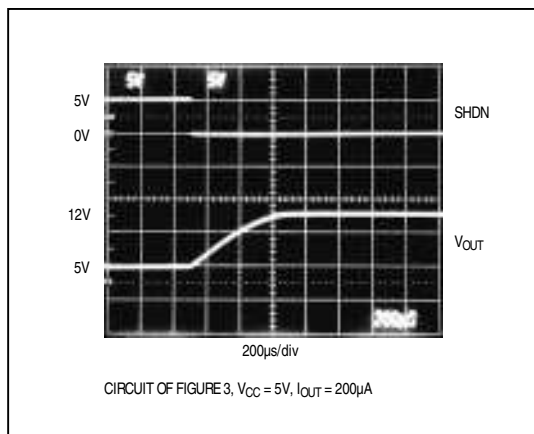

Figure 2. MAX662A Exiting Shutdown

Shutdown Mode

The MAX662A enters shutdown mode when SHDN is a logic high. SHDN is a TTL/CMOS-compatible input signal that is internally pulled up to V_{CC} . In shutdown mode, the charge-pump switching action is halted and V_{IN} is connected to V_{OUT} through a 1k Ω switch. When entering shutdown, V_{OUT} declines to V_{CC} in typically 13ms. Connect SHDN to ground for normal operation. When $V_{CC} = 5V$, it takes typically 400 μ s for the output to reach 12V after SHDN goes low (Figure 2).

Applications Information

Compatibility with MAX662

The MAX662A is a 100%-compatible upgrade of the MAX662. The MAX662A does not require capacitor C3, although its presence does not affect performance.

Capacitor Selection

Charge-Pump Capacitors, C1 and C2

The capacitance values of the charge-pump capacitors C1 and C2 are critical. Use ceramic or tantalum capacitors in the 0.22 μ F to 1.0 μ F range. For applications requiring operation over extended and/or military temperature ranges, use 1.0 μ F tantalum capacitors for C1 and C2 (Figure 3b).

Input and Output Capacitors, C4 and C5

The type of input bypass capacitor (C4) and output filter capacitor (C5) affects performance. Tantalums, ceramics or aluminum electrolytics are suggested. For smallest size, use Sprague 595D475X9016A7 surface-mount capacitors, which are 3.51mm x 1.81mm. For lowest ripple, use low-ESR through-hole ceramic or tantalum capacitors. For lowest cost, use aluminum electrolytic or tantalum capacitors.

Figure 3a shows the component values for proper operation over the commercial temperature range using minimum board space. The input bypass capacitor (C4) and output filter capacitor (C5) should both be at least 4.7 μ F when using Sprague's miniature 595D series of tantalum chip capacitors. Figure 3b shows the suggested component values for applications over extended and/or military temperature ranges.

The values of C4 and C5 can be reduced to 2 μ F and 1 μ F, respectively, when using ceramic capacitors. If using aluminum electrolytics, choose capacitance values of 10 μ F or larger for C4 and C5. Note that as V_{CC} increases above 5V and the output current decreases, the amount of ripple at V_{OUT} increases due to the slower oscillator frequency combined with the higher input voltage. Increase the input and output bypass capacitance to reduce output ripple.

Table 1 lists various capacitor suppliers.

+12V, 30mA Flash Memory Programming Supply

MAX662A

Table 1. Capacitor Suppliers

Supplier	Phone Number	Fax Number	Capacitor	Capacitor Type*
Murata Erie	(814) 237-1431	(814) 238-0490	GRM42-6Z5U224M50	0.22µF Ceramic (SM)
			RPE123Z5U105M50V	1.0µF Ceramic (TH)
Sprague Electric	(603) 224-1961 (207) 324-4140	(603) 224-1430 (207) 324-7223	595D475X9016A7	4.7µF Tantalum (SM)
			595D105X9016A7	1.0µF Tantalum (SM)

*Note: (SM) denotes surface-mount component, (TH) denotes through-hole component.

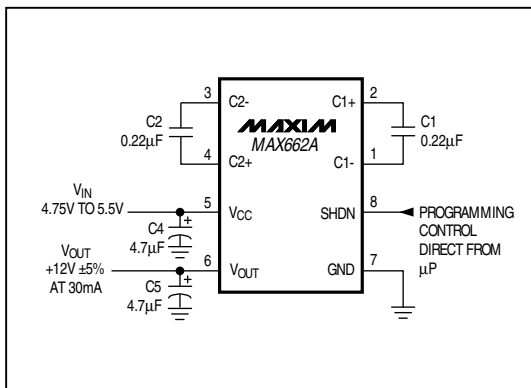

Figure 3a. Flash EEPROM Programming Power Supply for Commercial Temperature Range Applications

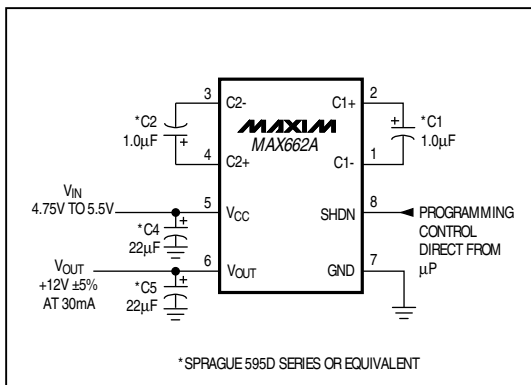

Figure 3b. Flash EEPROM Programming Power Supply for Extended and/or Military Temperature Range Applications

Layout Considerations

Layout is critical, due to the MAX662A's high oscillator frequency. Good layout ensures stability and helps maintain the output voltage under heavy loads. For best performance, use very short connections to the capacitors. The order of importance is: C4, C5, C1, C2.

Flash EEPROM Applications

The circuit of Figure 3a is a +12V ±5% 30mA flash EEPROM programming power supply. A microprocessor controls the programming voltage via the SHDN pin. When SHDN is low, the output voltage (which is connected to the flash memory V_{PP} supply-voltage pin) rises to +12V to facilitate programming the flash memory. When SHDN is high, the output voltage is connected to V_{IN} through an internal 1kΩ resistor.

Paralleling Devices

Two MAX662As can be placed in parallel to increase output drive capability. The V_{CC}, V_{OUT}, and GND pins can be paralleled, reducing pin count. Use a single bypass capacitor and a single output filter capacitor with twice the capacitance value if the two devices can be placed close to each other. If the MAX662As cannot be placed close together, use separate bypass and output capacitors. The amount of output ripple observed will determine whether single input bypass and output filter capacitors can be used. Under certain conditions, one device may supply the total output current. Therefore, regardless of the number of devices in parallel, the maximum continuous current must not exceed 50mA.

12V and 20V Dual-Output Power Supply

Using the charge-pump voltage-doubler circuit of Figure 4, the MAX662A can produce a +20V supply from a single +5V supply. Figure 5 shows the current capability of the +20V supply.

+12V, 30mA Flash Memory Programming Supply

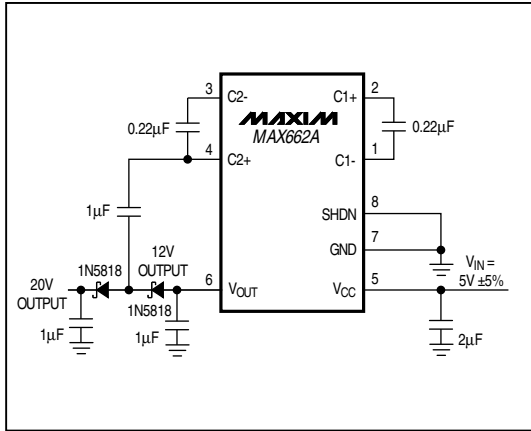

Figure 4. +12V and +20V Dual Supply from a +5V Input

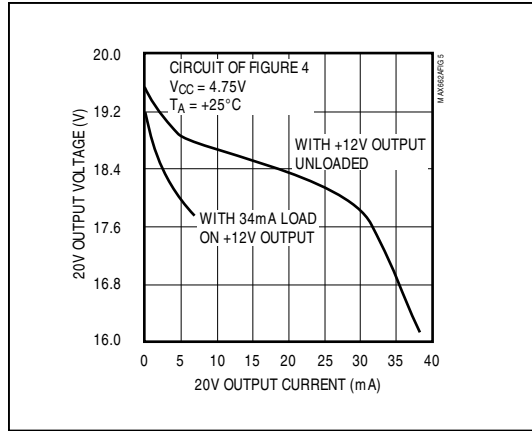
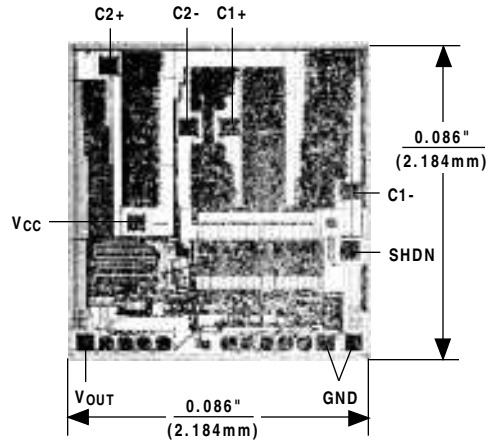

Figure 5. +20V Supply Output Current Capability

Chip Topography



TRANSISTOR COUNT: 225
SUBSTRATE CONNECTED TO V_{OUT}