

Multichemistry Battery Chargers with Automatic System Power Selector

ABSOLUTE MAXIMUM RATINGS

DCIN, CSSP, CSSN, SRC, ACOK to GND.....-0.3V to +30V
 DHIV SRC + 0.3, SRC - 6V
 DHI, PDL, PDS to GND-0.3V to (V_{SRC} + 0.3)
 BATT, CSIP, CSIN to GND-0.3V to +20V
 CSIP to CSIN or CSSP to CSSN or PGND to GND ...-0.3V to +0.3V
 CCI, CCS, CCV, DLO, IINP, REF,
 ACIN to GND-0.3V to (V_{LDO} + 0.3V)
 DLOV, VCTL, ICTL, MODE, CLS, LDO,
 PKPRES to GND-0.3V to +6V

DLOV to LDO.....-0.3V to +0.3V
 DLO to PGND-0.3V to (DLOV + 0.3V)
 LDO Short-Circuit Current.....50mA
 Continuous Power Dissipation (T_A = +70°C)
 28-Pin TQFN (derate 20.8mW/°C above +70°C) 1666mW
 Operating Temperature Range-40°C to +85°C
 Junction Temperature..... +150°C
 Storage Temperature Range-60°C to +150°C
 Lead Temperature (soldering, 10s)+300°C

Stresses beyond those listed under "Absolute Maximum Ratings" may cause permanent damage to the device. These are stress ratings only, and functional operation of the device at these or any other conditions beyond those indicated in the operational sections of the specifications is not implied. Exposure to absolute maximum rating conditions for extended periods may affect device reliability.

ELECTRICAL CHARACTERISTICS

(Circuit of Figure 1, V_{DCIN} = V_{CSPP} = V_{CSSN} = 18V, V_{BATT} = V_{CSIP} = V_{CSIN} = 12V, V_{VCTL} = V_{ICTL} = 1.8V, MODE = float, ACIN = 0, CLS = REF, GND = PGND = 0, PKPRES = GND, LDO = DLOV, T_A = 0°C to +85°C, unless otherwise noted. Typical values are at T_A = +25°C.)

PARAMETER	SYMBOL	CONDITIONS	MIN	TYP	MAX	UNITS
CHARGE VOLTAGE REGULATION						
VCTL Range			0		3.6	V
Battery Regulation Voltage Accuracy		V _{VCTL} = 3.6V (3 or 4 cells); not including VCTL resistor tolerances	-0.8		+0.8	%
		V _{VCTL} = 3.6V/20 (3 or 4 cells); not including VCTL resistor tolerances	-0.8		+0.8	
		V _{VCTL} = 3.6V (3 or 4 cells); including VCTL resistor tolerances of 1%	-1.0		+1.0	
		V _{VCTL} = V _{LDO} (3 or 4 cells, default threshold of 4.2V/cell)	-0.5		+0.5	
VCTL Default Threshold		V _{VCTL} rising	4.1		4.3	V
VCTL Input Bias Current		V _{VCTL} = 3V	0		2.5	μA
		V _{DCIN} = 0, V _{VCTL} = 5V	0		12	
CHARGE-CURRENT REGULATION						
ICTL Range		MAX1909	0		3.6	V
		MAX8725	0		3.2	
CSIP-to-CSIN Full-Scale Current-Sense Voltage			69.37	75.00	80.63	mV
Charge-Current Accuracy		MAX1909: V _{ICTL} = 3.6V (not including ICTL resistor tolerances)	-7.5		+7.5	%
		MAX8725: V _{ICTL} = 3.2V (not including ICTL resistor tolerances)	-5		+5	
		MAX1909: V _{ICTL} = 3.6V × 0.5, MAX8725: V _{ICTL} = 3.2V × 0.5 (not including ICTL resistor tolerances)	-5		+5	
		MAX1909: V _{ICTL} = 0.9V (not including ICTL resistor tolerances)	-7.5		+7.5	
		MAX8725: V _{ICTL} = 0.18V (not including ICTL resistor tolerances)	-30		+30	

Multichemistry Battery Chargers with Automatic System Power Selector

MAX1909/MAX8725

ELECTRICAL CHARACTERISTICS (continued)

(Circuit of Figure 1, $V_{DCIN} = V_{CSSP} = V_{CSSN} = 18V$, $V_{BATT} = V_{CSIP} = V_{CSIN} = 12V$, $V_{VCTL} = V_{ICTL} = 1.8V$, MODE = float, ACIN = 0, CLS = REF, GND = PGND = 0, PKPRES = GND, LDO = DLOV, $T_A = 0^{\circ}C$ to $+85^{\circ}C$, unless otherwise noted. Typical values are at $T_A = +25^{\circ}C$.)

PARAMETER	SYMBOL	CONDITIONS	MIN	TYP	MAX	UNITS
Charge-Current Accuracy		MAX1909: $V_{ICTL} = 3.6V \times 0.5$, MAX8725: $V_{ICTL} = 3.2V \times 0.5$ (including ICTL resistor tolerances of 1%)	-7.0		+7.0	%
		$V_{ICTL} = V_{LDO}$ (default threshold of 45mV)	-5		+5	
V_{ICTL} Default Threshold		V_{ICTL} rising	4.1	4.2	4.3	V
BATT/CSIP/CSIN Input Voltage Range			0		19	V
CSIP/CSIN Input Current		Charging enabled		350	650	μA
		Charging disabled; $V_{DCIN} = 0$ or $V_{ICTL} = 0$		0.1	1	
ICTL Power-Down Mode Threshold Voltage		MAX1909			0.75	V
		MAX8725			0.06	
ICTL Power-Up Mode Threshold Voltage		MAX1909	0.85			V
		MAX8725	0.11			
ICTL Input Bias Current		$V_{ICTL} = 3V$	-1		+1	μA
		$V_{DCIN} = 0V$, $V_{ICTL} = 5V$	-1		+1	
INPUT CURRENT REGULATION						
CSSP-to-CSSN Full-Scale Current-Sense Voltage			72.75	75.00	77.25	mV
Input Current-Limit Accuracy		$V_{CLS} = REF$	-3		+3	%
		$V_{CLS} = REF \times 0.75$	-3		+3	
		$V_{CLS} = REF \times 0.5$	-4		+4	
CSSP/CSSN Input Voltage Range			8.0		28	V
CSSP/CSSN Input Current		$V_{CSSP} = V_{CSSN} = V_{DCIN} > 8.0V$		450	730	μA
		$V_{DCIN} = 0$		0.1	1	
CLS Input Range			1.6		REF	V
CLS Input Bias Current		$V_{CLS} = 2.0V$	-1		+1	μA
IINP Transconductance		$V_{CSSP} - V_{CSSN} = 56mV$	2.7	3.0	3.3	mA/V
IINP Accuracy		$V_{CSSP} - V_{CSSN} = 75mV$, terminated with $10k\Omega$	-7.5		+7.5	%
		$V_{CSSP} - V_{CSSN} = 56mV$, terminated with $10k\Omega$	-5		+5	
		$V_{CSSP} - V_{CSSN} = 20mV$, terminated with $10k\Omega$	-10		+10	
IINP Output Current		$V_{CSSP} - V_{CSSN} = 150mV$, $V_{IINP} = 0V$	350			μA
IINP Output Voltage		$V_{CSSP} - V_{CSSN} = 150mV$, $V_{IINP} = float$	3.5			V

Multichemistry Battery Chargers with Automatic System Power Selector

ELECTRICAL CHARACTERISTICS (continued)

(Circuit of Figure 1, $V_{DCIN} = V_{CSSP} = V_{CSSN} = 18V$, $V_{BATT} = V_{CSIP} = V_{CSIN} = 12V$, $V_{VCTL} = V_{ICTL} = 1.8V$, $MODE = float$, $ACIN = 0$, $CLS = REF$, $GND = PGND = 0$, $PKPRES = GND$, $LDO = DLOV$, $T_A = 0^{\circ}C$ to $+85^{\circ}C$, unless otherwise noted. Typical values are at $T_A = +25^{\circ}C$.)

PARAMETER	SYMBOL	CONDITIONS	MIN	TYP	MAX	UNITS
SUPPLY AND LINEAR REGULATOR						
DCIN Input Voltage Range	V_{DCIN}		8.0		28	V
DCIN Undervoltage-Lockout Trip Point		DCIN falling	7	7.4		V
		DCIN rising		7.5	7.85	
DCIN Quiescent Current	I_{DCIN}	$8.0V < V_{DCIN} < 28V$		2.7	6	mA
BATT Input Current	I_{BATT}	$V_{BATT} = 19V$, $V_{DCIN} = 0V$, or $ICTL = 0V$		0.1	1	μA
		$V_{BATT} = 16.8V$, $V_{DCIN} = 19V$, $ICTL = 0V$		0.1	1	
		$V_{BATT} = 2V$ to $19V$, $V_{DCIN} > V_{BATT} + 0.3V$		200	500	
LDO Output Voltage		$8.0V < V_{DCIN} < 28V$, no load	5.25	5.4	5.55	V
LDO Load Regulation		$0 < I_{LDO} < 10mA$		80	115	mV
LDO Undervoltage-Lockout Trip Point		$V_{DCIN} = 8.0V$	3.20	4	5.15	V
REFERENCE						
REF Output Voltage	Ref	$0 < I_{REF} < 500\mu A$	4.2023	4.2235	4.2447	V
REF Undervoltage-Lockout Trip Point		REF falling		3.1	3.9	V
TRIP POINTS						
BATT POWER_FAIL Threshold		$V_{DCIN} - V_{BATT}$, V_{DCIN} falling	50	100	150	mV
BATT POWER_FAIL Threshold Hysteresis			100	200	300	mV
ACIN Threshold		ACIN rising	2.007	2.048	2.089	V
ACIN Threshold Hysteresis			10	20	30	mV
ACIN Input Bias Current		$V_{ACIN} = 2.048V$	-1		+1	μA
SWITCHING REGULATOR						
DHI Off-Time		$V_{BATT} = 16.0V$, $V_{DCIN} = 19V$, $V_{MODE} = 3.6V$	360	400	440	ns
DHI Minimum Off-Time		$V_{BATT} = 16.0V$, $V_{DCIN} = 17V$, $V_{MODE} = 3.6V$	260	300	350	ns
DLOV Supply Current	I_{DLOV}	DLO low		5	10	μA
Sense Voltage for Minimum Discontinuous Mode Ripple Current				7.5		mV
Cycle-by-Cycle Current-Limit Sense Voltage				97		mV
Sense Voltage for Battery Undervoltage Charge Current		MAX1909 only, BATT = 3.0V per cell	3	4.5	6	mV
Battery Undervoltage Threshold		MAX1909 only, $MODE = float$ (3 cell), V_{BATT} rising	9.18		9.42	V
		MAX1909 only, $MODE = LDO$ (4 cell), V_{BATT} rising	12.235		12.565	
DHIV Output Voltage		With respect to SRC	-4.5	-5.0	-5.5	V

Multichemistry Battery Chargers with Automatic System Power Selector

MAX1909/MAX8725

ELECTRICAL CHARACTERISTICS (continued)

(Circuit of Figure 1, $V_{DCIN} = V_{CSSP} = V_{CSSN} = 18V$, $V_{BATT} = V_{CSIP} = V_{CSIN} = 12V$, $V_{VCTL} = V_{ICTL} = 1.8V$, $MODE = float$, $ACIN = 0$, $CLS = REF$, $GND = PGND = 0$, $PKPRES = GND$, $LDO = DLOV$, $T_A = 0^{\circ}C$ to $+85^{\circ}C$, unless otherwise noted. Typical values are at $T_A = +25^{\circ}C$.)

PARAMETER	SYMBOL	CONDITIONS	MIN	TYP	MAX	UNITS
DHIV Sink Current			10			mA
DHI On-Resistance Low		$DHI = V_{DHIV}$, $I_{DHI} = -10mA$		2	5	Ω
DHI On-Resistance High		$DHI = V_{CSSN}$, $I_{DHI} = 10mA$		2	4	Ω
DLO On-Resistance High		$V_{DLOV} = 4.5V$, $I_{DLO} = +100mA$		3	7	Ω
DLO On-Resistance Low		$V_{DLOV} = 4.5V$, $I_{DLO} = -100mA$		1	3	Ω
ERROR AMPLIFIERS						
GMV Loop Transconductance		$V_{CTL} = 3.6$, $V_{BATT} = 16.8V$, $MODE = LDO$	0.0625	0.125	0.2500	mA/V
		$V_{CTL} = 3.6$, $V_{BATT} = 12.6V$, $MODE = FLOAT$	0.0833	0.167	0.3330	
GMI Loop Transconductance		MAX1909: $I_{CTL} = 3.6V$, MAX8725: $V_{ICTL} = 3.2V$, $V_{CSSP} - V_{CSIN} = 75mV$	0.5	1	2	mA/V
GMS Loop Transconductance		$V_{CLS} = 2.048V$, $V_{CSSP} - V_{CSSN} = 75mV$	0.5	1	2	mA/V
CCI/CCS/CCV Clamp Voltage		$0.25V < V_{CCV} < 2.0V$, $0.25V < V_{CCI} < 2.0V$, $0.25V < V_{CCS} < 2.0V$	150	300	600	mV
LOGIC LEVELS						
MODE Input Low Voltage					0.8	V
MODE Input Middle Voltage			1.6	1.8	2.0	V
MODE Input High Voltage			2.8			V
MODE Input Bias Current		$MODE = 0V$ or $3.6V$	-2		+2	μA
ACOK AND PKPRES						
ACOK Input Voltage Range			0		28	V
ACOK Sink Current		$V_{ACOK} = 0.4V$, $ACIN = 1.5V$	1			mA
ACOK Leakage Current		$V_{ACOK} = 28V$, $ACIN = 2.5V$			1	μA
PKPRES Input Voltage Range			0		LDO	V
PKPRES Input Bias Current			-1		+1	μA
PKPRES Battery Removal Detect Threshold		MAX8725, \overline{PKPRES} rising	55			% of LDO
PKPRES Hysteresis		MAX8725		1		%
PDS, PDL SWITCH CONTROL						
PDS Switch Turn-Off Threshold		$V_{DCIN} - V_{BATT}$, V_{DCIN} falling	50	100	150	mV
PDS Switch Threshold Hysteresis		$V_{DCIN} - V_{BATT}$	100	200	300	mV
PDS Output Low Voltage, PDS Below SRC		$I_{PDS} = 0A$	8	10	12	V
PDS Turn-On Current		$PDS = SRC$	6	12		mA
PDS Turn-Off Current		$V_{PDS} = V_{SRC} - 2V$, $V_{DCIN} = 16V$	10	50		mA
PDL Switch Turn-On Threshold		$V_{DCIN} - V_{BATT}$, V_{DCIN} falling	50	100	150	mV
PDL Switch Threshold Hysteresis		$V_{DCIN} - V_{BATT}$	100	200	300	mV

Multichemistry Battery Chargers with Automatic System Power Selector

ELECTRICAL CHARACTERISTICS (continued)

(Circuit of Figure 1, $V_{DCIN} = V_{CSSP} = V_{CSSN} = 18V$, $V_{BATT} = V_{CSIP} = V_{CSIN} = 12V$, $V_{VCTL} = V_{ICTL} = 1.8V$, $MODE = float$, $ACIN = 0$, $CLS = REF$, $GND = PGND = 0$, $PKPRES = GND$, $LDO = DLOV$, $T_A = 0^{\circ}C$ to $+85^{\circ}C$, unless otherwise noted. Typical values are at $T_A = +25^{\circ}C$.)

PARAMETER	SYMBOL	CONDITIONS	MIN	TYP	MAX	UNITS
PDL Turn-On Resistance		PDL = GND	50	100	150	k Ω
PDL Turn-Off Current		$V_{SRC} - V_{PDL} = 1.5V$	6	12		mA
SRC Input Bias Current		SRC = 19V, DCIN = 0V			1	μA
		SRC = 19, $V_{BATT} = 16V$		450	1000	
Delay Time Between PDL and PDS Transitions			2.5	5	7.5	μs

ELECTRICAL CHARACTERISTICS

(Circuit of Figure 1, $V_{DCIN} = V_{CSSP} = V_{CSSN} = 18V$, $V_{BATT} = V_{CSIP} = V_{CSIN} = 12V$, $V_{VCTL} = V_{ICTL} = 1.8V$, $MODE = float$, $ACIN = 0$, $CLS = REF$, $GND = PGND = 0$, $PKPRES = GND$, $LDO = DLOV$, $T_A = -40^{\circ}C$ to $+85^{\circ}C$, unless otherwise noted.)

PARAMETER	SYMBOL	CONDITIONS	MIN	TYP	MAX	UNITS
CHARGE VOLTAGE REGULATION						
VCTL Range			0		3.6	V
Battery Regulation Voltage Accuracy		$V_{VCTL} = 3.6V$ (3 or 4 cells); not including VCTL resistor tolerances	-0.8		+0.8	%
		$V_{VCTL} = 3.6V/20$ (3 or 4 cells); not including VCTL resistor tolerances	-0.8		+0.8	
		$V_{VCTL} = 3.6V$ (3 or 4 cells); including VCTL resistor tolerances of 1%	-1.0		+1.0	
		$V_{VCTL} = V_{LDO}$ (3 or 4 cells, default threshold of 4.2V/cell)	-0.8		+0.8	
VCTL Default Threshold		V_{VCTL} rising	4.1		4.3	V
VCTL Input Bias Current		$V_{VCTL} = 3V$	0		2.5	μA
		$V_{DCIN} = 0V$, $V_{VCTL} = 5V$	0		12	
CHARGE-CURRENT REGULATION						
ICTL Range		MAX1909	0		3.6	V
		MAX8725	0		3.2	
CSIP-to-CSIN Full-Scale Current-Sense Voltage			69.37		80.63	mV
Charge-Current Accuracy		MAX1909: $V_{ICTL} = 3.6V$ (not including ICTL resistor tolerances)	-7.5		+7.5	%
		MAX8725: $V_{ICTL} = 3.2V$ (not including ICTL resistor tolerances)	-5		+5	
		MAX1909: $V_{ICTL} = 3.6V \times 0.5$, MAX8725: $V_{ICTL} = 3.2V \times 0.5$ (not including ICTL resistor tolerances)	-5		+5	
		MAX1909: $V_{ICTL} = 0.9V$ (not including ICTL resistor tolerances)	-7.5		+7.5	
		MAX8725: $V_{ICTL} = 0.18V$ (not including ICTL resistor tolerances)	-30		+30	

Multichemistry Battery Chargers with Automatic System Power Selector

MAX1909/MAX8725

ELECTRICAL CHARACTERISTICS (continued)

(Circuit of Figure 1, $V_{DCIN} = V_{CSSP} = V_{CSSN} = 18V$, $V_{BATT} = V_{CSIP} = V_{CSIN} = 12V$, $V_{VCTL} = V_{ICTL} = 1.8V$, MODE = float, ACIN = 0, CLS = REF, GND = PGND = 0, PKPRES = GND, LDO = DLOV, $T_A = -40^{\circ}C$ to $+85^{\circ}C$, unless otherwise noted.)

PARAMETER	SYMBOL	CONDITIONS	MIN	TYP	MAX	UNITS
Charge-Current Accuracy		MAX1909: $V_{ICTL} = 3.6V \times 0.5$, MAX8725: $V_{ICTL} = 3.2V \times 0.5$ (including ICTL resistor tolerances of 1%)	-7.0		+7.0	%
		$V_{ICTL} = V_{LDO}$ (default threshold of 45mV)	-5		+5	
VICTL Default Threshold		V_{ICTL} rising	4.3			V
BATT/CSIP/CSIN Input Voltage Range			0		19	V
CSIP/CSIN Input Current		Charging enabled			650	μA
ICTL Power-Down Mode Threshold Voltage		MAX1909			0.75	V
		MAX8725			0.06	
ICTL Power-Up Mode Threshold Voltage		MAX1909	0.85			V
		MAX8725	0.11			
INPUT CURRENT REGULATION						
CSSP-to-CSSN Full-Scale Current-Sense Voltage			72.75		77.25	mV
Input Current-Limit Accuracy		$V_{CLS} = REF$	-3		+3	%
		$V_{CLS} = REF \times 0.75$	-3		+3	
		$V_{CLS} = REF \times 0.5$	-4		+4	
CSSP/CSSN Input Voltage Range			8.0		28	V
CSSP/CSSN Input Current		$V_{CSSP} = V_{CSSN} = V_{DCIN} > 8.0V$			730	μA
CLS Input Range			1.6		REF	V
IINP Transconductance		$V_{CSSP} - V_{CSSN} = 56mV$	2.7		3.3	mA/V
IINP Accuracy		$V_{CSSP} - V_{CSSN} = 75mV$, terminated with $10k\Omega$	-7.5		+7.5	%
		$V_{CSSP} - V_{CSSN} = 56mV$, terminated with $10k\Omega$	-5		+5	
		$V_{CSSP} - V_{CSSN} = 20mV$, terminated with $10k\Omega$	-10		+10	
IINP Output Current		$V_{CSSP} - V_{CSSN} = 150mV$, $V_{IINP} = 0V$	350			μA
IINP Output Voltage		$V_{CSSP} - V_{CSSN} = 150mV$, $V_{IINP} = float$	3.5			V
SUPPLY AND LINEAR REGULATOR						
DCIN Input Voltage Range	V_{DCIN}		8.0		28	V
DCIN Undervoltage-Lockout Trip Point		DCIN falling	7			V
		DCIN rising			7.85	
DCIN Quiescent Current	I_{DCIN}	$8.0V < V_{DCIN} < 28V$			6	mA
BATT Input Current	I_{BATT}	$V_{BATT} = 2V$ to $19V$, $V_{DCIN} > V_{BATT} + 0.3V$			500	μA
LDO Output Voltage		$8.0V < V_{DCIN} < 28V$, no load	5.25		5.55	V
LDO Load Regulation		$0 < I_{LDO} < 10mA$			115	mV

Multichemistry Battery Chargers with Automatic System Power Selector

ELECTRICAL CHARACTERISTICS (continued)

(Circuit of Figure 1, $V_{DCIN} = V_{CSSP} = V_{CSSN} = 18V$, $V_{BATT} = V_{CSIP} = V_{CSIN} = 12V$, $V_{VCTL} = V_{ICTL} = 1.8V$, MODE = float, ACIN = 0, CLS = REF, GND = PGND = 0, PKPRES = GND, LDO = DLOV, $T_A = -40^{\circ}C$ to $+85^{\circ}C$, unless otherwise noted.)

PARAMETER	SYMBOL	CONDITIONS	MIN	TYP	MAX	UNITS
LDO Undervoltage-Lockout Trip Point		$V_{DCIN} = 8.0V$	3.20		5.15	V
REFERENCE						
REF Output Voltage	Ref	$0 < I_{REF} < 500\mu A$	4.1960		4.2520	V
REF Undervoltage-Lockout Trip Point		REF falling			3.9	V
TRIP POINTS						
BATT POWER_FAIL Threshold		$V_{DCIN} - V_{BATT}$, V_{DCIN} falling	50		150	mV
BATT POWER_FAIL Threshold Hysteresis			100		300	mV
ACIN Threshold		ACIN rising	2.007		2.089	V
ACIN Threshold Hysteresis			10		30	mV
SWITCHING REGULATOR						
DHI Off-Time		$V_{BATT} = 16.0V$, $V_{DCIN} = 19V$, $V_{MODE} = 3.6V$	360		440	ns
DHI Minimum Off-Time		$V_{BATT} = 16.0V$, $V_{DCIN} = 17V$, $V_{MODE} = 3.6V$	260		350	ns
DLOV Supply Current	I_{DLOV}	DLO low			10	μA
Sense Voltage for Battery Undervoltage Charge Current		MAX1909 only, BATT = 3.0V per cell	3		6	mV
Battery Undervoltage Threshold		MAX1909 only, MODE = float (3 cell), V_{BATT} rising	9.18		9.42	V
		MAX1909 only, MODE = LDO (4 cell), V_{BATT} rising	12.235		12.565	
DHIV Output Voltage		With respect to SRC	-4.5		-5.5	V
DHIV Sink Current			10			mA
DHI On-Resistance Low		$DHI = V_{DHIV}$, $I_{DHI} = -10mA$			5	Ω
DHI On-Resistance High		$DHI = V_{CSSN}$, $I_{DHI} = 10mA$			4	Ω
DLO On-Resistance High		$V_{DLOV} = 4.5V$, $I_{DLO} = +100mA$			7	Ω
DLO On-Resistance Low		$V_{DLOV} = 4.5V$, $I_{DLO} = -100mA$			3	Ω
ERROR AMPLIFIERS						
GMV Loop Transconductance		$V_{CTL} = 3.6$, $V_{BATT} = 16.8V$, MODE = LDO	0.0625		0.2500	mA/V
		$V_{CTL} = 3.6$, $V_{BATT} = 12.6V$, MODE = FLOAT	0.0833		0.3330	
GMI Loop Transconductance		MAX1909: $I_{CTL} = 3.6V$, MAX8725: $V_{ICTL} = 3.2V$, $V_{CSSP} - V_{CSIN} = 75mV$	0.5		2.0	mA/V
GMS Loop Transconductance		$V_{CLS} = 2.048V$, $V_{CSSP} - V_{CSSN} = 75mV$	0.5		2.0	mA/V
CCI/CCS/CCV Clamp Voltage		$0.25V < V_{CCV} < 2.0V$, $0.25V < V_{CCI} < 2.0V$, $0.25V < V_{CCS} < 2.0V$	150		600	mV
LOGIC LEVELS						
MODE Input Low Voltage					0.8	V
MODE Input Middle Voltage			1.6		2.0	V

Multichemistry Battery Chargers with Automatic System Power Selector

ELECTRICAL CHARACTERISTICS (continued)

(Circuit of Figure 1, $V_{DCIN} = V_{CSSP} = V_{CSSN} = 18V$, $V_{BATT} = V_{CSIP} = V_{CSIN} = 12V$, $V_{VCTL} = V_{ICTL} = 1.8V$, MODE = float, ACIN = 0, CLS = REF, GND = PGND = 0, PKPRES = GND, LDO = DLOV, $T_A = -40^{\circ}C$ to $+85^{\circ}C$, unless otherwise noted.)

PARAMETER	SYMBOL	CONDITIONS	MIN	TYP	MAX	UNITS
MODE Input High Voltage			2.8			V
ACOK AND PKPRES						
ACOK Input Voltage Range			0		28	V
ACOK Sink Current		$V_{ACOK} = 0.4V$, ACIN = 1.5V	1			mA
\overline{PKPRES} Input Voltage Range			0		LDO	V
\overline{PKPRES} Battery Removal Detect Threshold		MAX8725, \overline{PKPRES} rising	55			% of LDO
PDS, PDL SWITCH CONTROL						
PDS Switch Turn-Off Threshold		$V_{DCIN} - V_{BATT}$, V_{DCIN} falling	50		150	mV
PDS Switch Threshold Hysteresis		$V_{DCIN} - V_{BATT}$	100		300	mV
PDS Output Low Voltage, PDS Below SRC		$I_{PDS} = 0A$	8		12	V
PDS Turn-On Current		PDS = SRC	6			mA
PDS Turn-Off Current		$V_{PDS} = V_{SRC} - 2V$, $V_{DCIN} = 16V$	10			mA
PDL Switch Turn-On Threshold		$V_{DCIN} - V_{BATT}$, V_{DCIN} falling	50		150	mV
PDL Switch Threshold Hysteresis		$V_{DCIN} - V_{BATT}$	100		300	mV
PDL Turn-On Resistance		PDL = GND	50		150	k Ω
PDL Turn-Off Current		$V_{SRC} - V_{PDL} = 1.5V$	6			mA
SRC Input Bias Current		SRC = 19, $V_{BATT} = 16V$			1000	μA

Note 1: Guaranteed by design. Not production tested.

Typical Operating Characteristics

(Circuit of Figure 2, $V_{DCIN} = 20V$, charge current = 3A, 4 Li+ series cells, $T_A = +25^{\circ}C$, unless otherwise noted.)

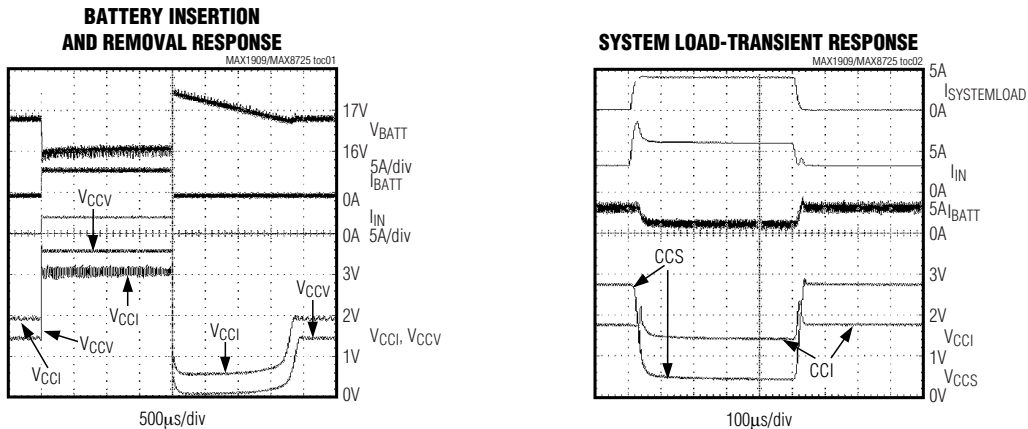

Multichemistry Battery Chargers with Automatic System Power Selector

Typical Operating Characteristics (continued)

(Circuit of Figure 2, $V_{DCIN} = 20V$, charge current = 3A, 4 Li+ series cells, $T_A = +25^\circ C$, unless otherwise noted.)

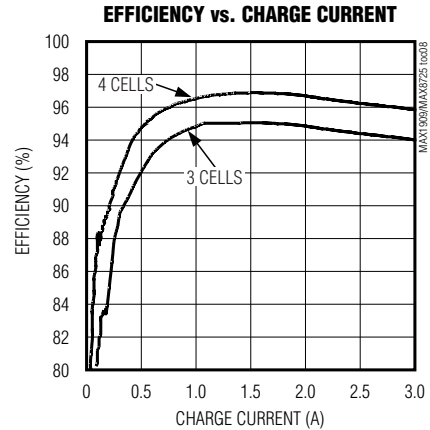
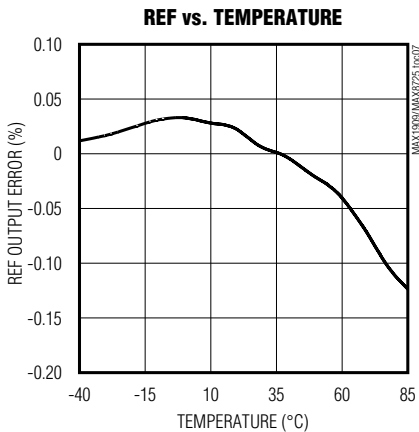
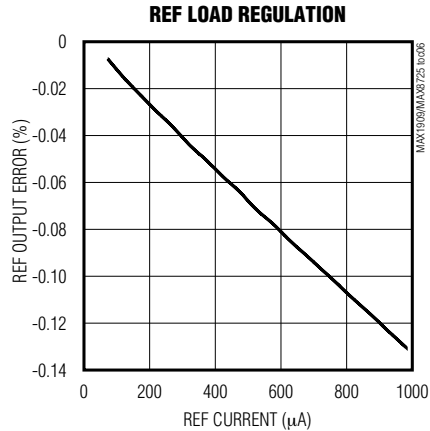
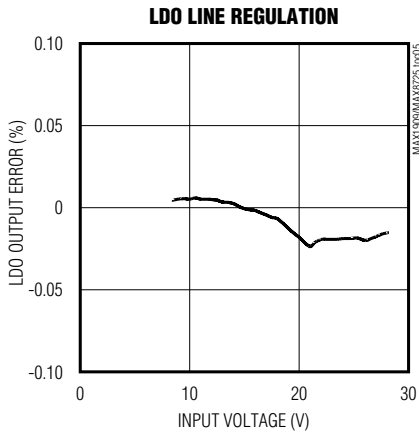
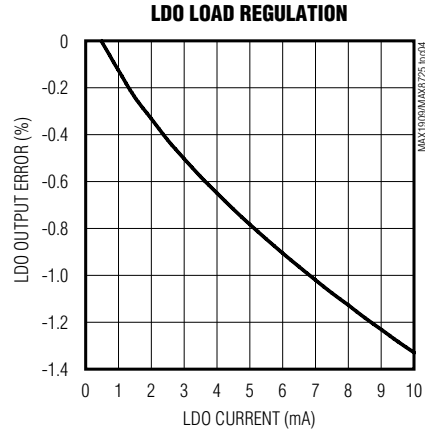
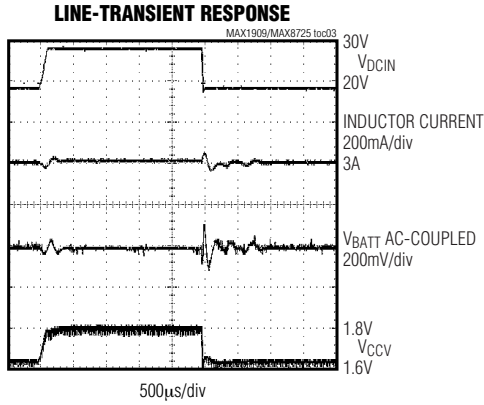

Multichemistry Battery Chargers with Automatic System Power Selector

MAX1909/MAX8725

Typical Operating Characteristics (continued)

(Circuit of Figure 2, $V_{DCIN} = 20V$, charge current = 3A, 4 Li+ series cells, $T_A = +25^\circ C$, unless otherwise noted.)

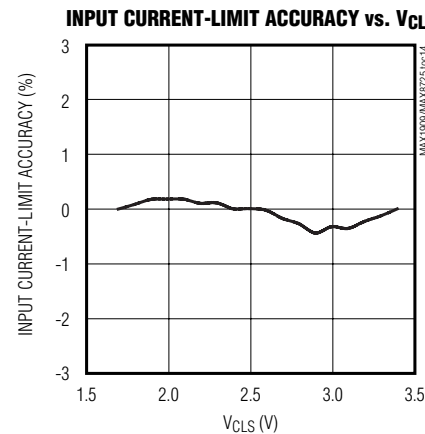
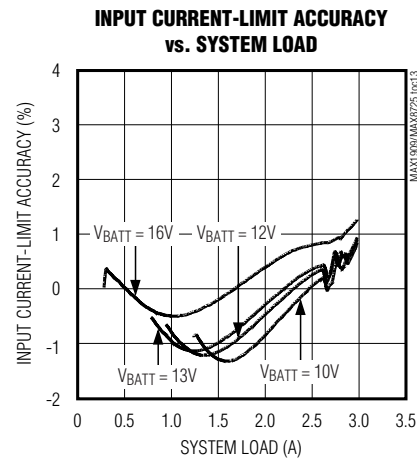
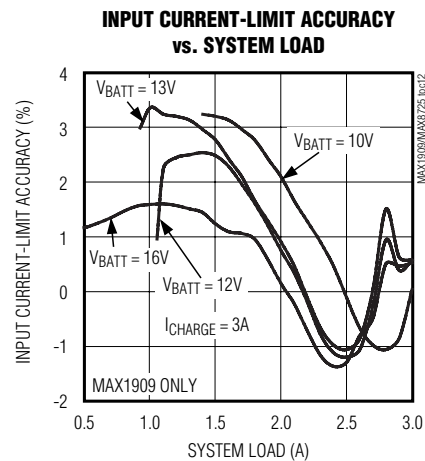
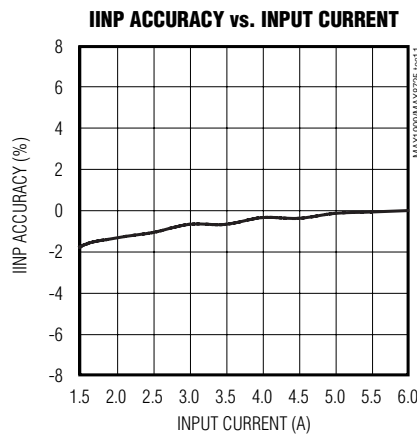
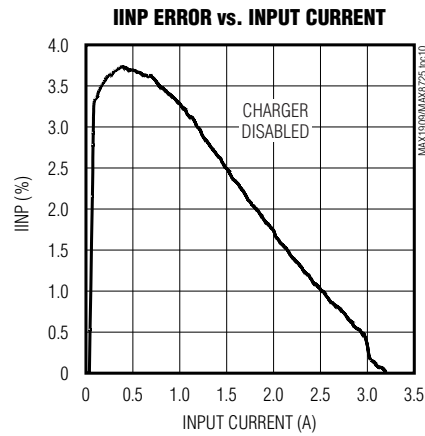
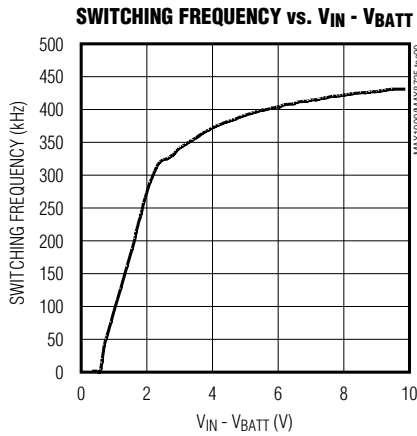

Multichemistry Battery Chargers with Automatic System Power Selector

Typical Operating Characteristics (continued)

(Circuit of Figure 2, $V_{DCIN} = 20V$, charge current = 3A, 4 Li+ series cells, $T_A = +25^\circ C$, unless otherwise noted.)

**PDL-PDS SWITCHING,
AC ADAPTER INSERTION**

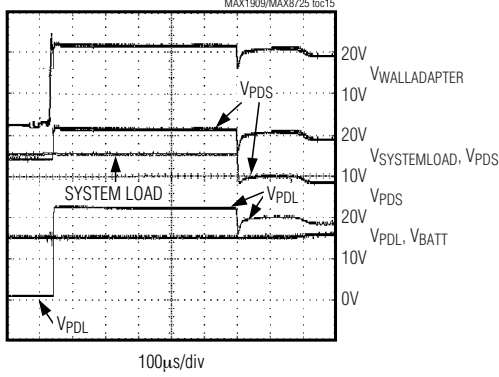

**PDS-PDL SWITCHOVER,
WALL ADAPTER REMOVAL**

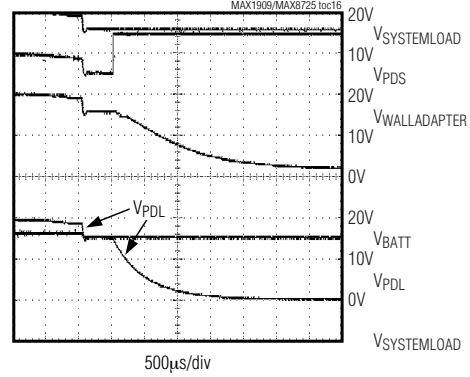

**PDS-PDL SWITCHOVER,
BATTERY INSERTION**

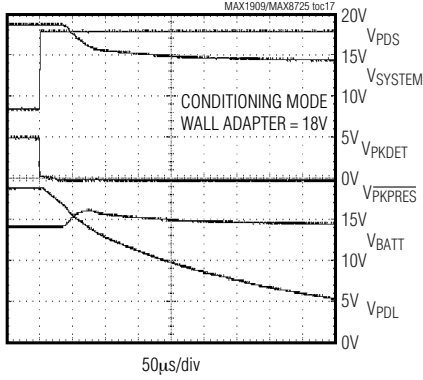

**PDL-PDS SWITCHING,
BATTERY REMOVAL**

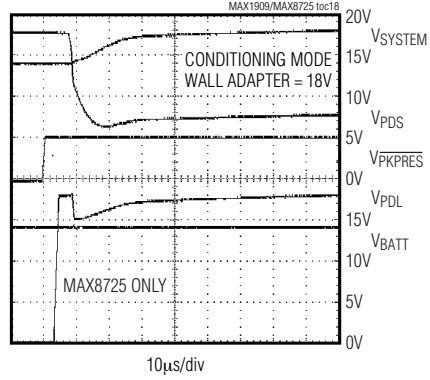

Multichemistry Battery Chargers with Automatic System Power Selector

Pin Description

PIN	NAME	FUNCTION
1	DCIN	DC Supply Voltage Input. Bypass DCIN with a 1 μ F capacitor to power ground.
2	LDO	Device Power Supply. Output of the 5.4V linear regulator supplied from DCIN. Bypass with a 1 μ F capacitor.
3	ACIN	AC Detect Input. This uncommitted comparator input can be used to detect the presence of the charger's power source. The comparator's open-drain output is the ACOK signal.
4	REF	4.2235V Voltage Reference. Bypass with a 1 μ F capacitor to GND.
5	GND	MAX1909: Ground this pin.
	PKPRES	MAX8725: Pull $\overline{\text{PKPRES}}$ high to disable charging. Used for detecting presence of battery pack.
6	ACOK	AC Detect Output. High-voltage open-drain output is high impedance when ACIN is greater than 2.048V. The ACOK output remains a high impedance when the MAX1909/MAX8725 are powered down.
7	MODE	Trilevel Input for Setting Number of Cells and Asserting the Conditioning Mode: MODE = GND; asserts conditioning mode. MODE = float; charge with 3 times the cell voltage programmed at VCTL. MODE = LDO; charge with 4 times the cell voltage programmed at VCTL.
8	IINP	Input Current Monitor Output. The current delivered at the IINP output is a scaled-down replica of the system load current plus the input-referred charge current sensed across CSSP and CSSN inputs. The transconductance of (CSSP - CSSN) to IINP is 3mA/V.
9	CLS	Source Current-Limit Input. Voltage input for setting the current limit of the input source.
10	ICTL	Input for Setting Maximum Output Current
11	VCTL	Input for Setting Maximum Output Voltage
12	CCI	Output Current-Regulation Loop-Compensation Point. Connect 0.01 μ F to GND.
13	CCV	Voltage-Regulation Loop-Compensation Point. Connect 10k Ω in series with 0.1 μ F to GND.
14	CCS	Input Current-Regulation Loop-Compensation Point. Use 0.01 μ F to GND.
15	GND	Analog Ground
16	BATT	Battery Voltage Feedback Input
17	CSIN	Output Current-Sense Negative Input
18	CSIP	Output Current-Sense Positive Input. Connect a current-sense resistor from CSIP to CSIN.
19	PGND	Power Ground
20	DLO	Low-Side Power-MOSFET Driver Output. Connect to low-side NMOS gate. When the MAX1909/MAX8725 are shut down, the DLO output is low.
21	DLOV	Low-Side Driver Supply. Bypass with a 1 μ F capacitor to ground.
22	DHIV	High-Side Driver Supply. Bypass with a 0.1 μ F capacitor to SRC.
23	DHI	High-Side Power-MOSFET Driver Output. Connect to high-side PMOS gate. When the MAX1909/MAX8725 are shut down, the DHI output is high.
24	SRC	Source Connection for Driver for PDS/PDL Switches. Bypass SRC to power ground with a 1 μ F capacitor.
25	CSSN	Input Current Sense for Charger (Negative Input)
26	CSSP	Input Current Sense for Charger (Positive Input). Connect a current-sense resistor from CSSP to CSSN.
27	PDS	Power-Source PMOS Switch Driver Output. When the MAX1909/MAX8725 are powered down, the PDS output is pulled to SRC through an internal 1M Ω resistor.
28	PDL	System-Load PMOS Switch Driver Output. When the MAX1909/MAX8725 are powered down, the PDL output is pulled to ground through an internal 100k Ω resistor.

MAX1909/MAX8725

Multichemistry Battery Chargers with Automatic System Power Selector

MAX1909/MAX8725

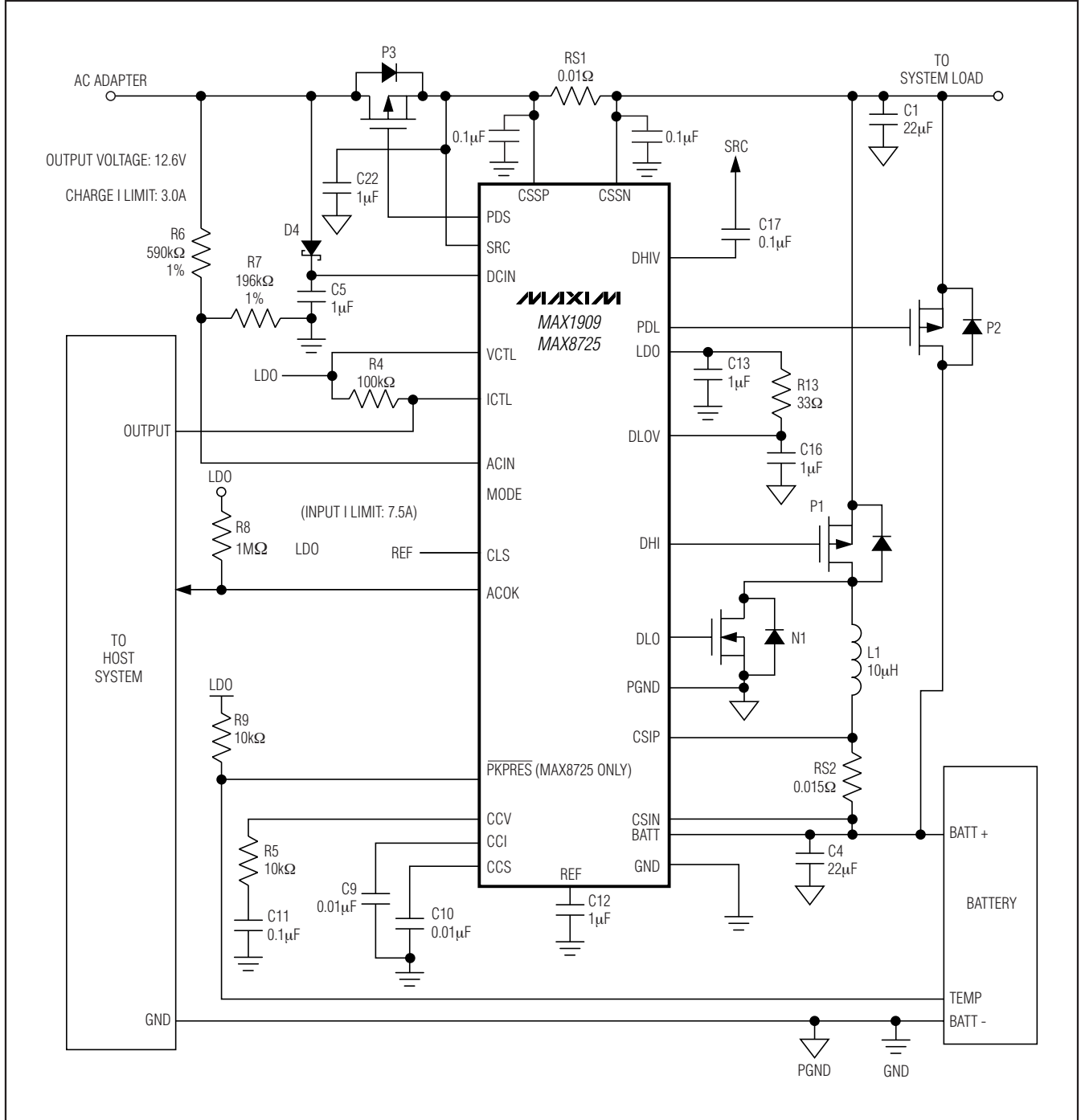

Figure 1. Typical Operating Circuit Demonstrating Hardwired Control

Multichemistry Battery Chargers with Automatic System Power Selector

MAX1909/MAX8725

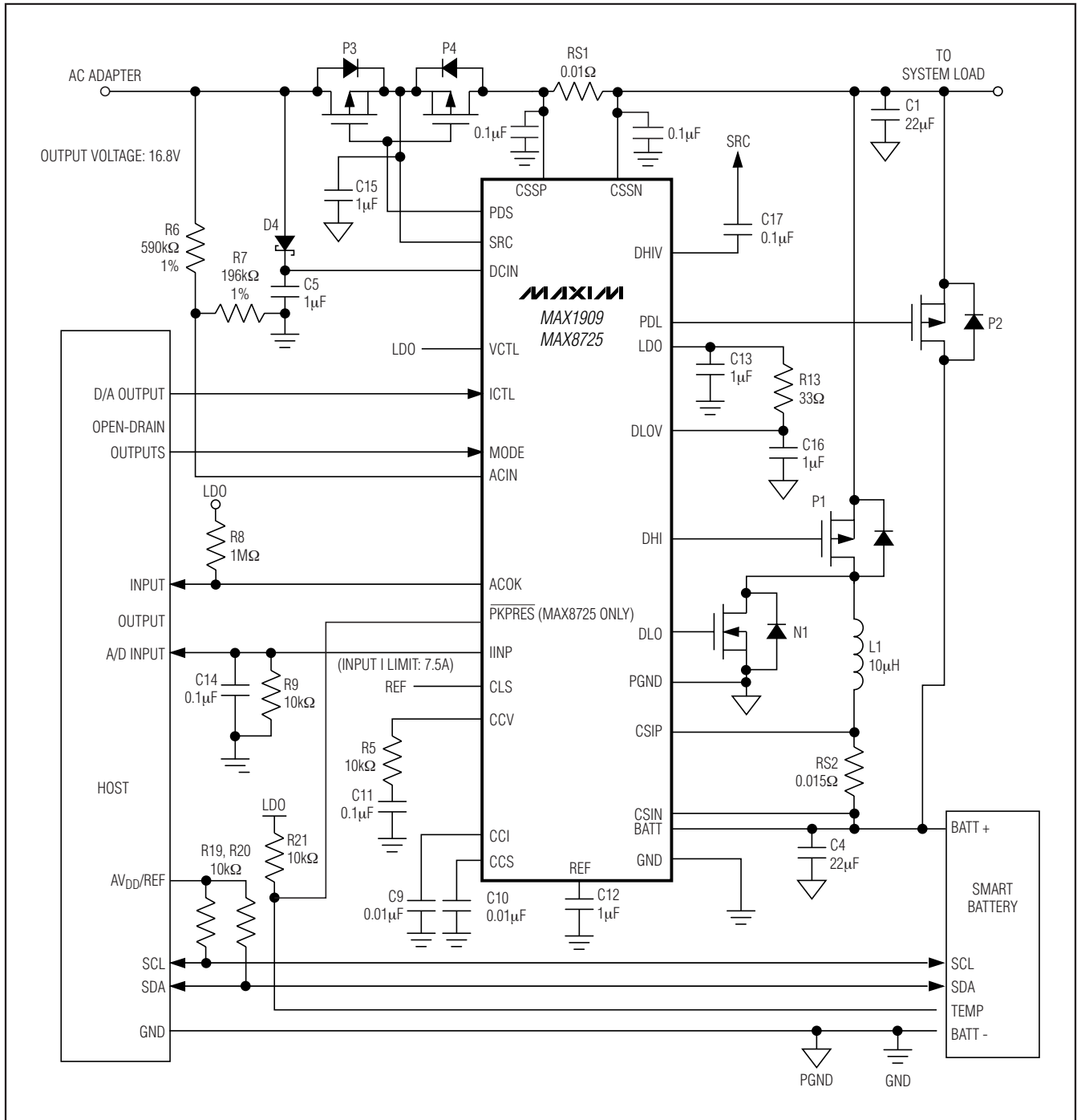

Figure 2. Smart-Battery Charger Circuit Demonstrating Operation with a Host Microcontroller

Multichemistry Battery Chargers with Automatic System Power Selector

MAX1909/MAX8725

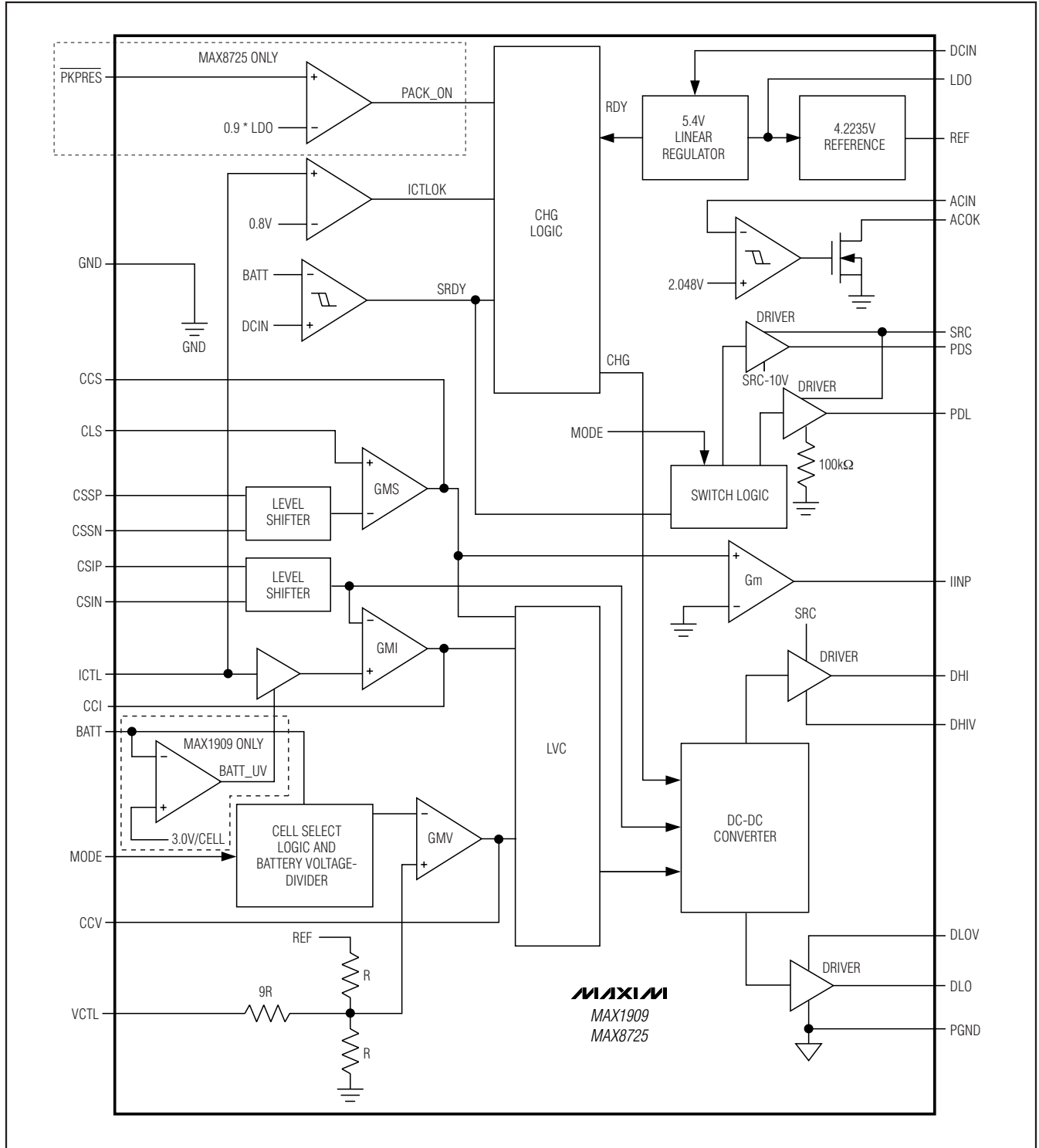

Figure 3. Functional Diagram

Multichemistry Battery Chargers with Automatic System Power Selector

Detailed Description

The MAX1909/MAX8725 include all of the functions necessary to charge Li+, NiMH, and NiCd batteries. A high-efficiency, synchronous-rectified step-down DC-DC converter is used to implement a precision constant-current, constant-voltage charger with input current limiting. The DC-DC converter uses external p-channel/n-channel MOSFETs as the buck switch and synchronous rectifier to convert the input voltage to the required charge current and voltage. The charge current and input current-limit sense amplifiers have low-input-referred offset errors and can use small-value sense resistors. The MAX1909/MAX8725 feature a voltage-regulation loop (CCV) and two current-regulation loops (CCI and CCS). The CCV voltage-regulation loop monitors BATT to ensure that its voltage never exceeds the voltage set by VCTL. The CCI battery current-regulation loop monitors current delivered to BATT to ensure that it never exceeds the current limit set by ICTL. A third loop (CCS) takes control and reduces the charge current when the sum of the system load and the input-referred charge current exceeds the power source current limit set by CLS. Tying CLS to the reference voltage provides a 7.5A input current limit with a 10mΩ sense resistor.

The ICTL, VCTL, and CLS analog inputs set the charge current, charge voltage, and input current limit, respectively. For standard applications, internal set points for ICTL and VCTL provide a 3A charge current using a 15mΩ sense resistor and a 4.2V per-cell charge voltage. The variable for controlling the number of cells is set with the MODE input. The MAX8725 includes a PKPRES input used for battery-pack detection.

Based on the presence or absence of the AC adapter, the MAX1909/MAX8725 automatically provide an open-drain logic output signal ACOK and select the appropriate source for supplying power to the system. A p-channel load switch controlled from the PDL output and a similar p-channel source switch controlled from the PDS output are used to implement this function. Using the MODE control input, the MAX1909/MAX8725 can be programmed to perform a relearning, or conditioning, cycle in which the battery is isolated from the charger and completely discharged through the system load. When the battery reaches 100% depth of discharge, it is recharged to full capacity.

The circuit shown in Figure 1 demonstrates a simple hardwired application, while Figure 2 shows a typical application for smart-battery systems with variable charge current and source switch configuration that supports battery conditioning. Smart-battery systems typically use a host μC to achieve this added functionality.

Setting the Charge Voltage

The MAX1909/MAX8725 use a high-accuracy voltage regulator for charge voltage. The VCTL input adjusts the battery output voltage. In default mode (VCTL = LDO), the overall accuracy of the charge voltage is ±0.5%. VCTL is allowed to vary from 0 to 3.6V, which provides a 10% adjustment range of the battery voltage. Limiting the adjustment range reduces the sensitivity of the charge voltage to external resistor tolerances from ±1% to ±0.05%. The overall accuracy of the charge voltage is better than ±1% when using ±1% resistors to divide down the reference to establish VCTL. The per-cell battery termination voltage is a function of the battery chemistry and construction. Consult the battery manufacturer to determine this voltage. The battery voltage is calculated by the equation:

$$V_{\text{BATT}} = \text{CELL} \left(V_{\text{REF}} + \left(\frac{V_{\text{VCTL}} - 1.8\text{V}}{9.52} \right) \right)$$

where $V_{\text{REF}} = 4.2235\text{V}$, and CELL is the number of cells selected with the MAX1909/MAX8725s' trilevel MODE control input. When MODE is tied to the LDO output, CELL = 4. When MODE is left floating, CELL = 3. When MODE is tied to ground, the charger enters conditioning mode, which is used to isolate the battery from the charger and discharge it through the system load. See the *Conditioning Mode* section. The internal error amplifier (GMV) maintains voltage regulation (see Figure 3 for the *Functional Diagram*). The voltage-error amplifier is compensated at CCV. The component values shown in Figures 1 and 2 provide suitable performance for most applications. Individual compensation of the voltage regulation and current-regulation loops allow for optimal compensation. See the *Compensation* section.

Setting the Charge Current

The voltage on the ICTL input sets the maximum voltage across current-sense resistor RS2, which in turn determines the charge current. The full-scale differential voltage between CSIP and CSIN is 75mV; thus, for a 0.015Ω sense resistor, the maximum charge current is 5A. In default mode (ICTL = LDO), the sense voltage is 45mV with an overall accuracy of ±5%. The charge current is programmed with ICTL using the equation:

$$I_{\text{CHG}} = \frac{0.075}{\text{RS2}} \times \frac{V_{\text{ICTL}}}{3.6\text{V}}$$

Multichemistry Battery Chargers with Automatic System Power Selector

The input range for ICTL is 0 to 3.6V on the MAX1909, and 0 to 3.2V on the MAX8725. The charger shuts down if ICTL is forced below 0.75V for the MAX1909 and 0.06V for the MAX8725. When choosing current-sense resistor RS2, note that it must have a sufficient power rating to handle the full-load current. The sense resistor's I²R power loss reduces charger efficiency. Adjusting ICTL to drop the voltage across the current-sense resistor improves efficiency, but may degrade accuracy due to the current-sense amplifier's input offset error. The charge-current error amplifier (GMI) is compensated at the CCI pin. See the *Compensation* section.

Conditioning Charge

The MAX1909 includes a battery voltage comparator that allows a conditioning charge of overdischarged Li+ battery packs. If the battery-pack voltage is less than 3.1V x the number of cells programmed by MODE, the MAX1909 charges the battery with 300mA current when using sense resistor RS2 = 0.015Ω. After the battery voltage exceeds the conditioning charge threshold, the MAX1909 resumes full-charge mode, charging to the programmed voltage and current limits. The MAX8725 does not provide automatic support for providing a conditioning charge. To configure the MAX8725 to provide a conditioning charge current, ICTL should be directly driven.

Setting the Input Current Limit

The total input current, from a wall cube or other DC source, is the sum of the system supply current and the current required by the charger. The MAX1909/MAX8725 reduce the source current by decreasing the charge current when the input current exceeds the set input current limit. This technique does not truly limit the input current. As the system supply current rises, the available charge current drops proportionally to zero. Thereafter, the total input current can increase without limit.

An internal amplifier compares the differential voltage between CSSP and CSSN to a scaled voltage set with the CLS input. V_{CLS} can be driven directly or set with a resistive voltage-divider between REF and GND. Connect CLS to REF to set the input current-limit sense voltage to the maximum value of 75mV. Calculate the input current as follows:

$$I_{IN} = \frac{0.075}{RS1} \times \frac{V_{CLS}}{V_{REF}}$$

V_{CLS} determines the reference voltage of the GMS error amplifier. Sense resistor RS1 sets the maximum allowable source current. Once the input current limit is reached, the charge current is decreased linearly until the input current is below the desired threshold.

Duty cycle affects the accuracy of the input current limit. AC load current also affects accuracy (see the *Typical Operating Characteristics*). Refer to the MAX1909/MAX8725 EV kit data sheet for more details on reducing the effects of switching noise.

When choosing the current-sense resistor RS1, carefully calculate its power rating. Take into account variations in the system's load current and the overall accuracy of the sense amplifier. Note that the voltage drop across RS1 contributes additional power loss, which reduces efficiency.

System currents normally fluctuate as portions of the system are powered up or put to sleep. Without input current regulation, the input source must be able to deliver the maximum system current and the maximum charger input current. By using the input current-limit circuit, the output current capability of the AC wall adapter can be lowered, reducing system cost.

Current Measurement

The MAX1909/MAX8725 include an input current monitor IINP. The current delivered at the IINP output is a scaled-down replica of the system load current plus the input-referred charge current that is sensed across CSSP and CSSN inputs. The output voltage range is 0 to 3V. The voltage of IINP is proportional to the input current according to the following equation:

$$V_{IINP} = I_{SOURCE} \times RS1 \times G_{IINP} \times R9$$

where I_{SOURCE} is the DC current supplied by the AC adapter power, G_{IINP} is the transconductance of IINP (3mA/V typ), and R9 is the resistor connected between IINP and ground.

Leave the IINP pin unconnected if not used.

LDO Regulator

LDO provides a 5.4V supply derived from DCIN and can deliver up to 10mA of extra load current. The low-side MOSFET driver is powered by DLOV, which must be connected to LDO as shown in Figure 1. LDO also supplies the 4.2235V reference (REF) and most of the control circuitry. Bypass LDO with a 1μF capacitor.

Shutdown and Charge Inhibit (PKPRES)

When the AC adapter is removed, the MAX1909/MAX8725 shut down to a low-power state that does not significantly load the battery. Under these conditions, a maximum of 6μA is drawn from the battery through the combined load of the SRC, CSSP, CSSN, CSIP, CSIN, and BATT inputs. The charger enters this low-power state when DCIN falls below the undervoltage-lockout (UVLO) threshold of 7V. The PDS switch turns off, the PDL switch turns on, and the system runs from the battery.

Multichemistry Battery Chargers with Automatic System Power Selector

The body diode of the PDL switch prevents the voltage on the power source output from collapsing.

Charging can also be inhibited by driving ICTL below 0.035V, which suspends switching and pulls CCI, CCS, and CCV to ground. The PDS and PDL drivers, LDO, input current monitor, and control logic (ACOK) all remain active in this state. Approximately 3mA of supply current is drawn from the AC adapter and 3 μ A (max) is drawn from the battery to support these functions.

In smart-battery systems, $\overline{\text{PKPRES}}$ is usually driven from a voltage-divider formed with a low-value resistor or PTC thermistor inside the battery pack and a local resistive pullup. This arrangement automatically detects the presence of a battery. The MAX8725 threshold voltage is 55% of V_{LDO} , with hysteresis of 1% V_{LDO} to prevent erratic transitions.

AC Adapter Detection and Power-Source Selection

The MAX1909/MAX8725 include a hysteretic comparator that detects the presence of an AC power adapter and automatically delivers power to the system load from the appropriate available power source. When the adapter is present, the open-drain ACOK output becomes high impedance. The switch threshold at ACIN is 2.048V. Use a resistive voltage-divider from the adapter's output to the ACIN pin to set the appropriate detection threshold. When charging, the battery is isolated from the system load with the p-channel PDL switch, which is biased off. When the adapter is absent, the drives to the switches change state in a fast break-before-make sequence. PDL begins to turn on 7.5 μ s after PDS begins to turn off.

The threshold for selecting between the PDL and PDS switches is set based on the voltage difference between the DCIN and the BATT pins. If this voltage difference drops below 100mV, the PDS is switched off and PDL is switched on. Under these conditions, the MAX1909/MAX8725 are completely powered down. The PDL switch is kept on with a 100k Ω pulldown resistor when the charger is powered down through ICTL or $\overline{\text{PKPRES}}$, or when the AC adapter is removed.

The drivers for PDL and PDS are fully integrated. The positive bias inputs for the drivers connect to the SRC pin and the negative bias inputs connect to a negative regulator referenced to SRC. With this arrangement, the drivers can swing from SRC to approximately 10V below SRC.

Conditioning Mode

The MAX1909/MAX8725 can be programmed to perform a conditioning cycle to calibrate the battery's fuel gauge. This cycle consists of isolating the battery from the charger and discharging it through the system load. When the battery reaches 100% depth of discharge, it is then recharged. Driving the MODE pin low places the MAX1909/MAX8725 in conditioning mode, which stops the charger from switching, turns the PDS switch off, and turns the PDL switch on.

To utilize the conditioning mode function, the configuration of the PDS switch must be changed to two source-connected FETs to prevent the AC adapter from supplying current to the system through the MOSFET's body diode. See Figure 2. The SRC pin must be connected to the common source node of the back-to-back FETs to properly drive the MOSFETs.

It is essential to alert the user that the system is performing a conditioning cycle. If the user terminates the cycle prematurely, the battery can be discharged even though the system was running off the AC adapter for a substantial period of time. If the AC adapter is in fact removed during conditioning, the MAX1909/MAX8725 keep the PDL switch on and the charger remains off as it would in normal operation.

In the MAX8725, if the battery is removed during conditioning mode, the $\overline{\text{PKPRES}}$ control overrides conditioning mode. When MODE is grounded and $\overline{\text{PKPRES}}$ goes high, the PDS switch starts turning on within 7.5 μ s and the system is powered from the AC adapter.

In the MAX1909, disable conditioning mode before the battery is overdischarged or removed.

DC-DC Converter

The MAX1909/MAX8725 employ a buck regulator with a PMOS high-side switch and a low-side NMOS synchronous rectifier. The MAX1909/MAX8725 feature a pseudo-fixed-frequency, cycle-by-cycle current-mode control scheme. The off-time is dependent upon V_{DCIN} , V_{BATT} , and a time constant, with a minimum t_{OFF} of 300ns. The MAX1909/MAX8725 can also operate in discontinuous conduction for improved light-load efficiency. The operation of the DC-DC controller is determined by the following four comparators as shown in Figure 4:

- **CCMP:** Compares the control point (lowest voltage clamp (LVC)) against the charge current (CSI). The high-side MOSFET on-time is terminated if the CCMP output is high.

Multichemistry Battery Chargers with Automatic System Power Selector

MAX1909/MAX8725

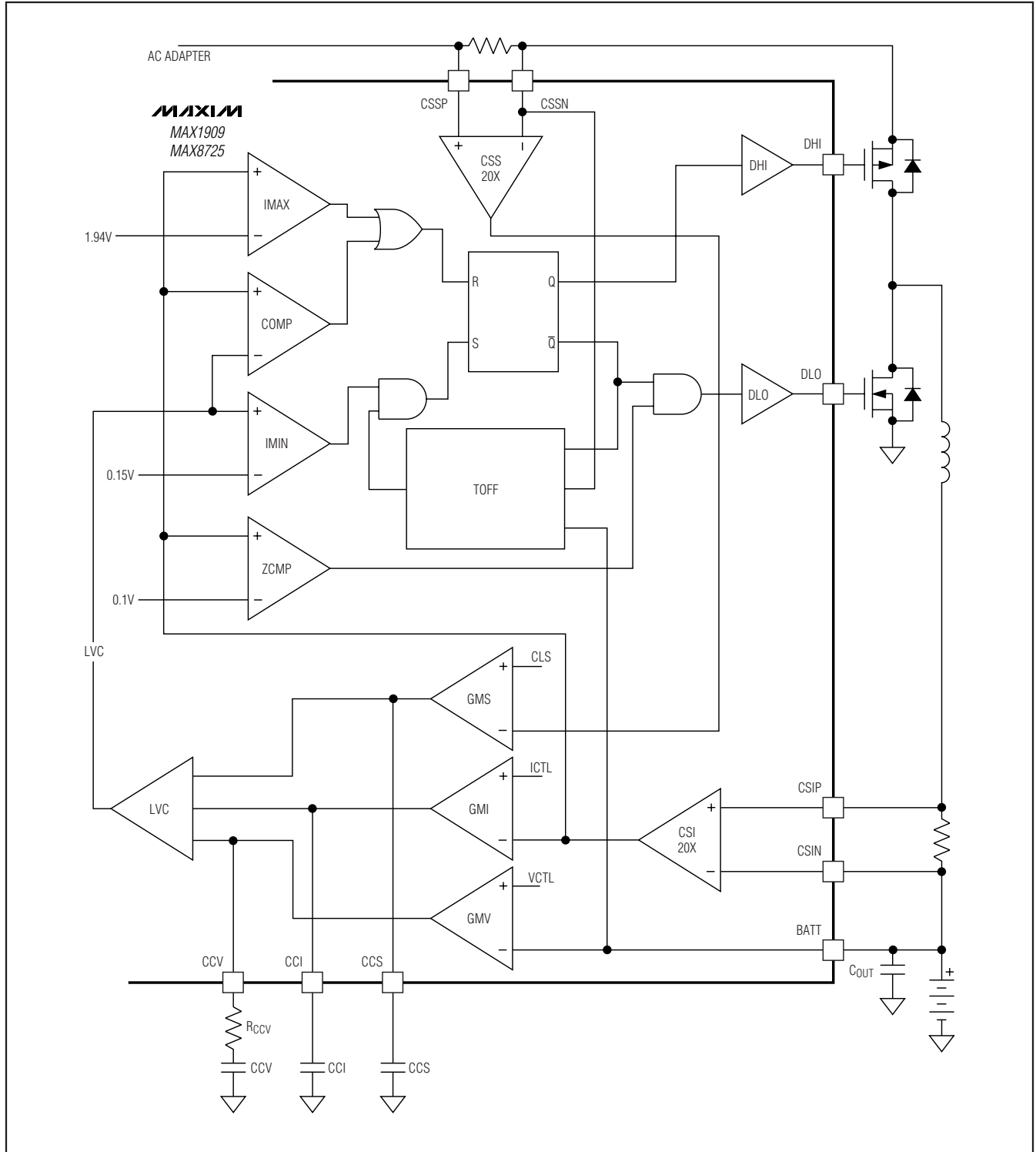

Figure 4. DC-DC Converter Functional Diagram

Multichemistry Battery Chargers with Automatic System Power Selector

- **IMIN:** Compares the control point (LVC) against 0.15V (typ). If IMIN output is low, then a new cycle cannot begin. This comparator determines whether the regulator operates in discontinuous mode.
- **IMAX:** Compares the charge current (CSI) to the internally fixed cycle-by-cycle current limit. The current-sense voltage limit is 97mV. With RS2 = 0.015Ω, this corresponds to 6A. The high-side MOSFET on-time is terminated if the IMAX output is high and a new cycle cannot begin until IMAX goes low. IMAX protects against sudden overcurrent faults.
- **ZCMP:** Compares the charge current (CSI) to 333mA (RS2 = 0.015Ω). The current-sense voltage threshold is 5mV. If ZCMP output is high, then both MOSFETs are turned off. The ZCMP comparator terminates the switch on-time in discontinuous mode.

CCV, CCI, CCS, and LVC Control Blocks

The MAX1909/MAX8725 control charge voltage (CCV control loop), charge current (CCI control loop), or input current (CCS control loop), depending on the operating conditions. The three control loops, CCV, CCI, and CCS, are brought together internally at the LVC amplifier. The output of the LVC amplifier is the feedback control signal for the DC-DC controller. The minimum voltage at CCV, CCI, or CCS appears at the output of the LVC amplifier and clamps the other two control loops to within 0.3V above the control point. Clamping the other two control loops close to the lowest control loop ensures fast transition with minimal overshoot when switching between different control loops (see the *Compensation* section).

Continuous Conduction Mode

With sufficient battery current loading, the MAX1909/MAX8725s' inductor current never reaches zero, which is defined as continuous conduction mode. If the BATT voltage is within the following range:

$$3.1V \times (\text{number of cells}) < V_{BATT} < (0.88 \times V_{DCIN})$$

the regulator is not in dropout and switches at $f_{NOM} = 400\text{kHz}$. The controller starts a new cycle by turning on the high-side p-channel MOSFET and turning off the low-side n-channel MOSFET. When the charge current is greater than the control point (LVC), CCMP goes high and the off-time is started. The off-time turns off the high-side p-channel MOSFET and turns on the low-side n-channel MOSFET. The operating frequency is governed by the off-time and is dependent upon V_{DCIN} and V_{BATT} . The off-time is set by the following equation:

$$t_{OFF} = \frac{1}{f_{NOM}} \frac{V_{CSSN} - V_{BATT}}{V_{CSSN}}$$

where $f_{NOM} = 400\text{kHz}$:

$$t_{ON} = \frac{L \times I_{RIPPLE}}{V_{CSSN} - V_{BATT}}$$

$$\text{where } I_{RIPPLE} = \frac{V_{BATT} \times t_{OFF}}{L}$$

$$f = \frac{1}{t_{ON} + t_{OFF}}$$

These equations describe the controller's pseudo-fixed-frequency performance over the most common operating conditions.

At the end of the fixed off-time, the controller can initiate a new cycle if the control point (LVC) is greater than 0.15V (IMIN = high) and the peak charge current is less than the cycle-by-cycle limit (IMAX = low). If the charge current exceeds I_{MAX} , the on-time is terminated by the IMAX comparator.

If during the off-time the inductor current goes to zero, ZCMP = high, both the high- and low-side MOSFETs are turned off until another cycle is ready to begin. This condition is discontinuous conduction. See the *Discontinuous Conduction* section.

There is a minimum 0.3μs off-time when the ($V_{DCIN} - V_{BATT}$) differential becomes too small. If $V_{BATT} \geq 0.88 \times V_{DCIN}$, then the threshold for minimum off-time is reached and the t_{OFF} is fixed at 0.3μs. The switching frequency in this mode varies according to the equation:

$$f = \frac{1}{t_{OFF} \left(\frac{V_{BATT}}{V_{CSSN} - V_{BATT}} + 1 \right)}$$

Discontinuous Conduction

The MAX1909/MAX8725 enter discontinuous-conduction mode when the output of the LVC control point falls below 0.15V. For RS2 = 0.015Ω, this corresponds to 0.5A:

$$I_{MIN} = \frac{0.15V}{20 \times RS2} = 0.5A$$

Multichemistry Battery Chargers with Automatic System Power Selector

In discontinuous mode, a new cycle is not started until the LVC voltage rises above 0.15V. Discontinuous-mode operation can occur during conditioning charge of overdischarged battery packs, when the charge current has been reduced sufficiently by the CCS control loop, or when the charger is in constant voltage mode with a nearly full battery pack.

Compensation

The charge voltage, charge current, and input current-limit regulation loops are compensated separately and independently at the CCV, CCI, and CCS pins.

CCV Loop Compensation

The simplified schematic in Figure 5 is sufficient to describe the operation of the MAX1909/MAX8725 when the voltage loop (CCV) is in control. The required compensation network is a pole-zero pair formed with C_{CV} and R_{CV} . The pole is necessary to roll off the voltage loop's response at low frequency. The zero is necessary to compensate the pole formed by the output capacitor and the load. R_{ESR} is the equivalent series resistance (ESR) of the charger output capacitor (C_{OUT}). R_L is the equivalent charger output load, where $R_L = \Delta V_{BATT} / \Delta I_{CHG}$. The equivalent output impedance of the GMV amplifier, R_{OGMV} , is greater than $10M\Omega$. The voltage loop transconductance ($GMV = I_{CCV} / V_{BATT}$) depends on the MODE input, which determines the number of cells. $GMV = 0.125mA/mV$ for 4 cells and $GMV = 0.167mA/mV$ for 3 cells. The DC-DC converter transconductance is dependent upon the charge current-sense resistor $RS2$:

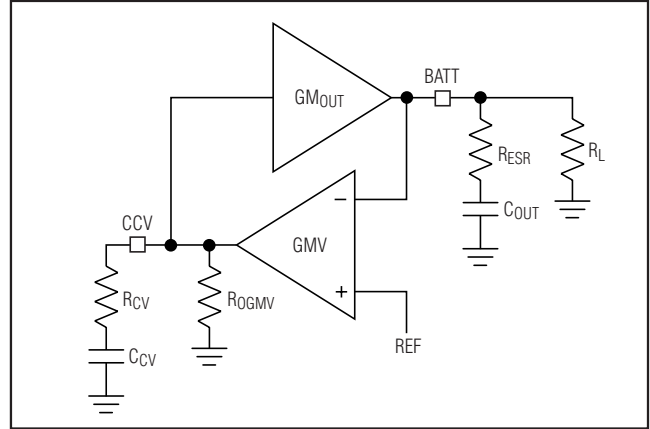

Figure 5. CCV Loop Diagram

$$GM_{OUT} = \frac{1}{A_{CSI} \times RS2}$$

where $A_{CSI} = 20$, and $RS2 = 0.015\Omega$ in the *Typical Operating Circuits* (Figures 1 and 2), so $GM_{OUT} = 3.33A/V$.

The loop transfer function is:

$$LTF = GM_{OUT} \times \frac{R_{OGMV} \times (1 + sC_{CV} \times R_{CV})}{(1 + sC_{CV} \times R_{OGMV})} \times \frac{R_L}{(1 + sC_{OUT} \times R_L)} GMV (1 + sC_{OUT} \times R_{ESR})$$

Table 1. Poles and Zeros of the Voltage-Loop Transfer Function

NO.	NAME	CALCULATION	DESCRIPTION
1	CCV pole	$f_{P_CV} = \frac{1}{2\pi R_{OGMV} \times C_{CV}}$	Lowest frequency pole created by C_{CV} and GMV's finite output resistance. Since R_{OGMV} is very large and not well controlled, the exact value for the pole frequency is also not well controlled ($R_{OGMV} > 10M\Omega$).
2	CCV zero	$f_{Z_CV} = \frac{1}{2\pi R_{CV} \times C_{CV}}$	Voltage-loop compensation zero. If this zero is at the same frequency or lower than the output pole f_{P_OUT} , then the loop transfer function approximates a single pole response near the crossover frequency. Choose C_{CV} to place this zero at least one decade below crossover to ensure adequate phase margin.
3	Output pole	$f_{P_OUT} = \frac{1}{2\pi R_L \times C_{OUT}}$	Output pole formed with the effective load resistance R_L and the output capacitance C_{OUT} . R_L influences the DC gain but does not affect the stability of the system or the crossover frequency.
4	Output zero	$f_{Z_OUT} = \frac{1}{2\pi R_{ESR} \times C_{OUT}}$	Output ESR Zero. This zero can keep the loop from crossing unity gain if f_{Z_OUT} is less than the desired crossover frequency; therefore, choose a capacitor with an ESR zero greater than the crossover frequency.

Multichemistry Battery Chargers with Automatic System Power Selector

The poles and zeros of the voltage-loop transfer function are listed from lowest frequency to highest frequency in Table 1.

Near crossover, C_{CV} has a much lower impedance than R_{OGMV} . Since C_{CV} is in parallel with R_{OGMV} , C_{CV} dominates the parallel impedance near crossover. Additionally, R_{CV} has a much higher impedance than C_{CV} and dominates the series combination of R_{CV} and C_{CV} , so:

$$\frac{R_{OGMV} \times (1 + sC_{CV} \times R_{CV})}{(1 + sC_{CV} \times R_{OGMV})} \approx R_{CV}$$

C_{OUT} also has a much lower impedance than R_L near crossover, so the parallel impedance is mostly capacitive and:

$$\frac{R_L}{(1 + sC_{OUT} \times R_L)} \approx \frac{1}{sC_{OUT}}$$

If R_{ESR} is small enough, its associated output zero has a negligible effect near crossover and the loop-transfer function can be simplified as follows:

$$LTF = GM_{OUT} \times \frac{R_{CV}}{sC_{OUT}} \times GMV$$

Setting the $LTF = 1$ to solve for the unity-gain frequency yields:

$$f_{CO_CV} = GM_{OUT} \times GMV \left(\frac{R_{CV}}{2\pi \times C_{OUT}} \right)$$

For stability, choose a crossover frequency lower than 1/10th of the switching frequency. Choosing a crossover frequency of 30kHz and solving for R_{CV} using the component values listed in Figure 1 yields:

MODE = LDO (4 cells)

GMV = 0.125μA/mV

$C_{OUT} = 22\mu F$

$V_{BATT} = 16.8V$

$R_L = 0.2\Omega$

$GM_{OUT} = 3.33A/V$

$f_{CO_CV} = 30kHz$

$f_{OSC} = 400kHz$

$$R_{CV} = \frac{2\pi \times C_{OUT} \times f_{CO_CV}}{GMV \times GM_{OUT}} = 10k\Omega$$

To ensure that the compensation zero adequately cancels the output pole, select $f_{z_CV} \leq f_{p_OUT}$:

$$C_{CV} \geq (R_L/R_{CV}) C_{OUT}$$

where $C_{CV} \geq 4nF$ (assuming 4 cells and 4A maximum charge current).

Figure 6 shows the Bode plot of the voltage-loop frequency response using the values calculated above.

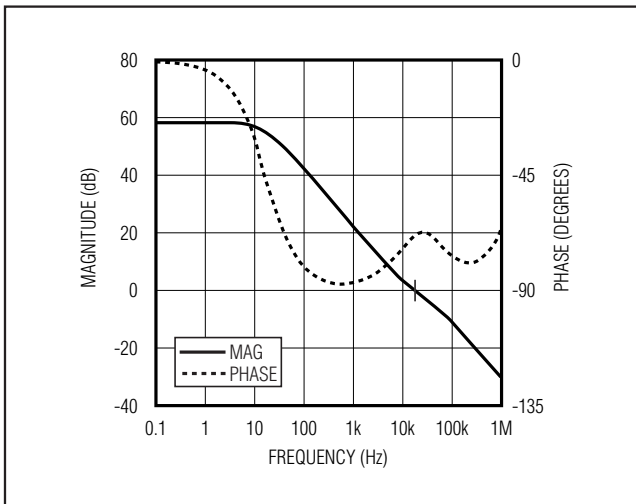

Figure 6. CCV Loop Response

CCI Loop Compensation

The simplified schematic in Figure 7 is sufficient to describe the operation of the MAX1909/MAX8725 when the battery current loop (CCI) is in control. Since the output capacitor's impedance has little effect on the response of the current loop, only a single pole is required to compensate this loop. A_{CSI} is the internal gain of the current-sense amplifier. $RS2$ is the charge current-sense resistor, $RS2 = 15m\Omega$. R_{OGMI} is the equivalent output impedance of the GMI amplifier, which is greater than $10M\Omega$. GMI is the charge-current amplifier transconductance = $1\mu A/mV$. GM_{OUT} is the DC-DC converter transconductance = $3.3A/V$.

The loop transfer function is given by:

$$LTF = GM_{OUT} \times A_{CSI} \times RS2 \times GMI \frac{R_{OGMI}}{1 + sR_{OGMI} \times C_{CI}}$$

Multichemistry Battery Chargers with Automatic System Power Selector

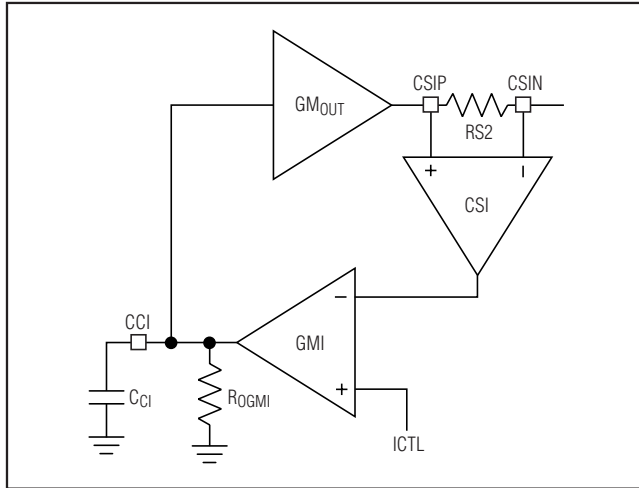

Figure 7. CCI Loop Diagram

This describes a single-pole system. Since:

$$GM_{OUT} = \frac{1}{A_{CSI} \times RS2}$$

the loop transfer function simplifies to:

$$LTF = GMI \frac{R_{OGMI}}{1 + sR_{OGMI} \times C_{CI}}$$

The crossover frequency is given by:

$$f_{CO_CI} = \frac{GMI}{2\pi C_{CI}}$$

For stability, choose a crossover frequency lower than 1/10th of the switching frequency:

$$C_{CI} = GMI / (2\pi f_{O_CI})$$

Choosing a crossover frequency of 30kHz and using the component values listed in Figure 1 yields $C_{CI} > 5.4nF$. Values for C_{CI} greater than 10 times the minimum value may slow down the current-loop response excessively. Figure 8 shows the Bode plot of the current-loop frequency response using the values calculated above.

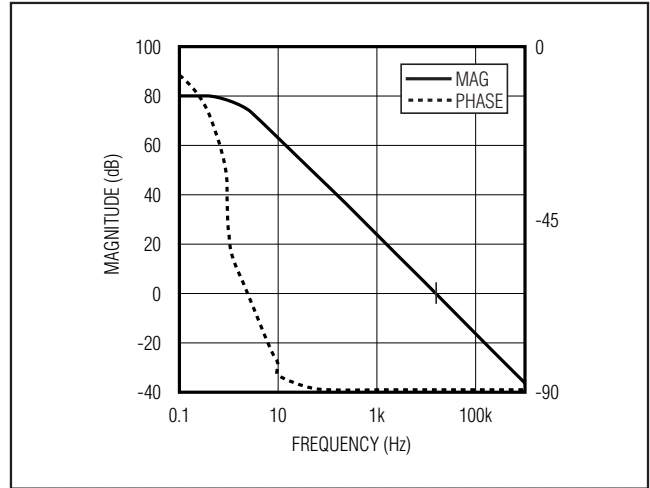

Figure 8. CCI Loop Response

CCS Loop Compensation

The simplified schematic in Figure 9 is sufficient to describe the operation of the MAX1909/MAX8725 when the input current-limit loop (CCS) is in control. Since the output capacitor's impedance has little effect on the response of the input current-limit loop, only a single pole is required to compensate this loop. A_{CSS} is the internal gain of the current-sense amplifier. $RS1$ is the input current-sense resistor; $RS1 = 10m\Omega$ in the typical operating circuits. R_{OGMS} is the equivalent output impedance of the GMS amplifier, which is greater than $10M\Omega$. GMS is the input current amplifier transconductance = $1\mu A/mV$. GM_{IN} is the DC-DC converter's input-referred transconductance = $(1/D) GM_{OUT} = (1/D) 3.3A/V$.

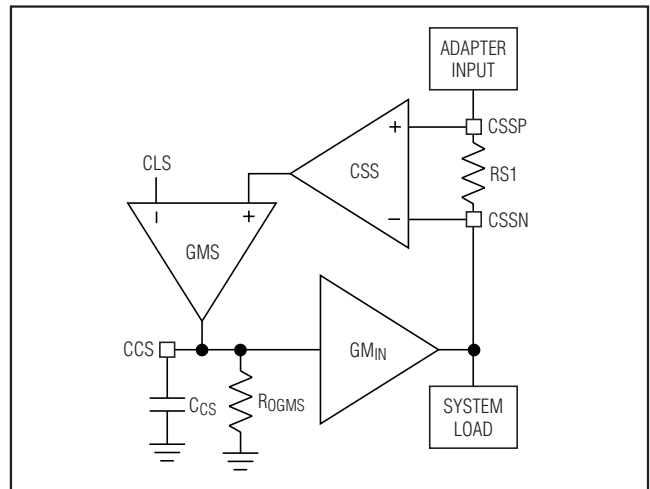

Figure 9. CCS Loop Diagram

Multichemistry Battery Chargers with Automatic System Power Selector

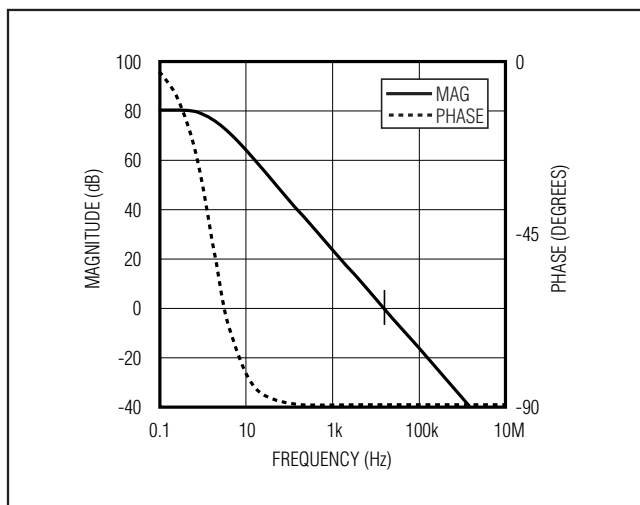

Figure 10. CCS Loop Response

The loop transfer function is given by:

$$LTF = GM_{IN} \times A_{CSS} \times RS1 \times GMS \frac{R_{OGMS}}{1 + sR_{OGMS} \times C_{CS}}$$

Since:

$$GM_{IN} = \frac{1}{A_{CSS} \times RS1}$$

the loop transfer function simplifies to:

$$LTF = GMS \frac{R_{OGMS}}{1 + sR_{OGMS} \times C_{CS}}$$

The crossover frequency is given by:

$$f_{CO_CS} = \frac{GMS}{2\pi C_{CS}}$$

For stability, choose a crossover frequency lower than 1/10th the switching frequency:

$$C_{CS} = GMS / (2\pi f_{CO_CS})$$

Choosing a crossover frequency of 30kHz and using the component values listed in Figure 1 yields $C_{CS} > 5.4nF$. Values for C_{CS} greater than 10 times the minimum value may slow down the input current-loop response excessively. Figure 10 shows the Bode plot of the input current-limit loop frequency response using the values calculated above.

MOSFET Drivers

The DHI and DLO outputs are optimized for driving moderately-sized power MOSFETs. The MOSFET drive capability is the same for both the low-side and high-side switches. This is consistent with the variable duty factor that occurs in the notebook computer environment where the battery voltage changes over a wide range. An adaptive dead-time circuit monitors the DLO output and prevents the high-side FET from turning on until DLO is fully off. There must be a low-resistance, low-inductance path from the DLO driver to the MOSFET gate for the adaptive dead-time circuit to work properly. Otherwise, the sense circuitry in the MAX1909/MAX8725 interpret the MOSFET gate as “off” while there is still charge left on the gate. Use very short, wide traces measuring 1.25mm to 2.5mm if the MOSFET is 25mm from the device. Unlike the DLO output, the DHI output uses a fixed-delay 50ns time to prevent the low-side FET from turning on until DHI is fully off. The same layout considerations should be used for routing the DHI signal to the high-side FET.

Since the transition time for a p-channel switch can be much longer than an n-channel switch, the dead time prior to the high-side PMOS turning on is more pronounced than in other synchronous step-down regulators, which use high-side n-channel switches. On the high-to-low transition, the voltage on the inductor’s “switched” terminal flies below ground until the low-side switch turns on. A similar dead-time spike occurs on the opposite low-to-high transition. Depending upon the magnitude of the load current, these spikes usually have a minor impact on efficiency.

The high-side driver (DHI) swings from SRC to 5V below SRC and typically sources 0.9A and sinks 0.5A from the gate of the p-channel FET. The internal pull-high transistors that drive DHI high are robust, with a 2.0Ω (typ) on-resistance.

The low-side driver (DLO) swings from DLOV to ground and typically sources 0.5A and sinks 0.9A from the gate of the n-channel FET. The internal pulldown transistors that drive DLO low are robust, with a 1.0Ω (typ) on-resistance. This helps prevent DLO from being pulled up when the high-side switch turns on, due to capacitive coupling from the drain to the gate of the low-side MOSFET. This places some restrictions on the FETs that can be used. Using a low-side FET with smaller gate-to-drain capacitance can prevent these problems.

Multichemistry Battery Chargers with Automatic System Power Selector

Table 2. Recommended Components

REFERENCE	QTY	DESCRIPTION
C1, C4	2	22 μ F \pm 20%, 35V E-size low-ESR tantalum capacitors AVX TPSE226M035R0300 Kemet T495X226M035AS
C5, C15	2	1 μ F \pm 10%, 25V, X7R ceramic capacitors (1206) Murata GRM31MR71E105K Taiyo Yuden TMK316BJ105KL TDK C3216X7R1E105K
C9, C10	2	0.01 μ F \pm 10%, 25V, X7R ceramic capacitors (0402) Murata GRP155R71E103K TDK C1005X7R1E103K
C11, C14, C17	3	0.1 μ F \pm 10%, 25V, X7R ceramic capacitors (0603) Murata GRM188R71E104K TDK C1608X7R1E104K
C12, C13, C16	3	1 μ F \pm 10%, 6.3V, X5R ceramic capacitors (0603) Murata GRM188R60J105K Taiyo Yuden JMK107BJ105KA TDK C1608X5R1A105K
D4	1	Schottky diode, 0.5A, 30V SOD-123 Diodes Inc. B0530W General Semiconductor MBR0530 ON Semiconductor MBR0530
D5	1	25V \pm 1% zener diode CMDZ5253B
L1	1	10 μ H, 4.4A inductor Sumida CDRH104R-100NC TOKO 919AS-100M

Design Procedure

Table 2 lists the recommended components and refers to the circuit of Figure 2. The following sections describe how to select these components.

MOSFET Selection

MOSFETs P2 and P3 (Figure 1) provide power to the system load when the AC adapter is inserted. These devices may have modest switching speeds, but must be able to deliver the maximum input current as set by RS1. As always, care should be taken not to exceed the device's maximum voltage ratings or the maximum operating temperature.

The p-channel/n-channel MOSFETs (P1, N1) are the switching devices for the buck controller. The guidelines

REFERENCE	QTY	DESCRIPTION
N1/P1	1	Dual n- and p-channel MOSFETs, 7A, 30V and -5A, -30V, 8-pin SO, MOSFET Fairchild FDS8958A or Single n-channel MOSFETs, +13.5A, +30V FDS6670S and Single p-channel MOSFETs, -13.5A, -30V FDS66709Z
P2, P3, P4	3	Single, p-channel, -11A, -30V, 8-pin SO MOSFETs Fairchild FDS6675
R4	1	100k Ω , \pm 5% resistor (0603)
R5, R9, R21	2	10k Ω \pm 1% resistors (0603)
R6	1	590k Ω \pm 1% resistor (0603)
R7	1	196k Ω \pm 1% resistor (0603)
R8	1	1M Ω \pm 5% resistor (0603)
R11	1	1k Ω \pm 5% resistor (0603)
R16	1	33 Ω \pm 5% resistor (0603)
R19, R20	2	10k Ω \pm 5% resistors (0603)
RS1	1	0.01 Ω \pm 1%, 0.5W sense resistor (2010) Vishay Dale WSL2010 0.010 1.0% IRC LRC-LR2010-01-R010-F
RS2	1	0.015 Ω \pm 1%, 0.5W sense resistor (2010) Vishay Dale WSL2010 0.015 1.0% IRC LRC-LR2010-01-R015-F
U1	1	MAX1909ETI/MAX8725ETI (28-pin thin QFN-EP)

for these devices focus on the challenge of obtaining high load-current capability when using high-voltage (>20V) AC adapters. Low-current applications usually require less attention. The high-side MOSFET (P1) must be able to dissipate the resistive losses plus the switching losses at both $V_{DCIN(MIN)}$ and $V_{DCIN(MAX)}$.

Ideally, the losses at $V_{DCIN(MIN)}$ should be roughly equal to losses at $V_{DCIN(MAX)}$, with lower losses in between. If the losses at $V_{DCIN(MIN)}$ are significantly higher than the losses at $V_{DCIN(MAX)}$, consider increasing the size of P1. Conversely, if the losses at $V_{DCIN(MAX)}$ are significantly higher than the losses at $V_{DCIN(MIN)}$, consider reducing the size of P1. If DCIN does not vary over a wide range, the minimum power dissipation occurs where the resistive losses equal the switching losses.

Multichemistry Battery Chargers with Automatic System Power Selector

Choose a low-side MOSFET that has the lowest possible on-resistance ($R_{DS(ON)}$), comes in a moderate-sized package, and is reasonably priced. Make sure that the DLO gate driver can supply sufficient current to support the gate charge and the current injected into the parasitic gate-to-drain capacitor caused by the high-side MOSFET turning on; otherwise, cross-conduction problems can occur.

The MAX1909/MAX8725 have an adaptive dead-time circuit that prevents the high-side and low-side MOSFETs from conducting at the same time (see the *MOSFET Drivers* section). Even with this protection, it is still possible for delays internal to the MOSFET to prevent one MOSFET from turning off when the other is turned on.

Select devices that have low turn-off times. To be conservative, make sure that $P1(t_{DOFF(MAX)}) - N1(t_{DON(MIN)}) < 40ns$. Failure to do so may result in efficiency-killing shoot-through currents. If delay mismatch causes shoot-through currents, consider adding extra capacitance from gate to source on N1 to slow down its turn-on time.

MOSFET Power Dissipation

Worst-case conduction losses occur at the duty factor extremes. For the high-side MOSFET, the worst-case power dissipation (PD) due to resistance occurs at the minimum supply voltage:

$$PD(P1) = \left(\frac{V_{BATT}}{V_{DCIN}} \right) \left(\frac{I_{LOAD}}{2} \right)^2 \times R_{DS(ON)}$$

Generally, a small high-side MOSFET is desired to reduce switching losses at high input voltages. However, the $R_{DS(ON)}$ required to stay within package power-dissipation limits often limits how small the MOSFET can be. The optimum occurs when the switching (AC) losses equal the conduction ($I^2R_{DS(ON)}$) losses. High-side switching losses do not usually become an issue until the input is greater than approximately 15V. Switching losses in the high-side MOSFET can become an insidious heat problem when maximum AC adapter voltages are applied, due to the squared term in the $CV^2 f$ switching-loss equation. If the high-side MOSFET that was chosen for adequate $R_{DS(ON)}$ at low supply voltages becomes extraordinarily hot when subjected to $V_{DCIN(MAX)}$, then choose a MOSFET with lower losses. Calculating the power dissipation in P1 due to switching losses is difficult since it must allow for difficult quantifying factors that influence the turn-on and turn-off times. These factors include the internal gate resistance, gate charge, threshold voltage, source inductance, and PC board layout characteristics. The

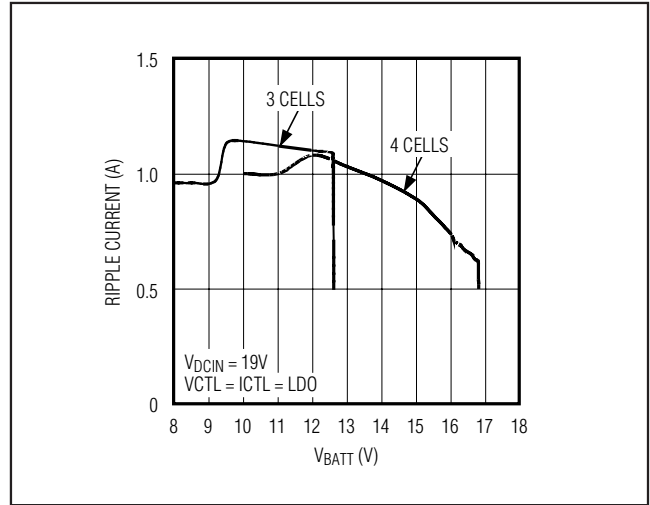

Figure 11. Ripple Current vs. Battery Voltage (MAX1909)

following switching-loss calculation provides only a very rough estimate and is no substitute for breadboard evaluation, preferably including a verification using a thermocouple mounted on P1:

$$PD(P1_Switching) = \frac{V_{DCIN(MAX)}^2 \times C_{RSS} \times f_{SW} \times I_{LOAD}}{2 I_{GATE}}$$

where C_{RSS} is the reverse transfer capacitance of P1, and I_{GATE} is the peak gate-drive source/sink current.

For the low-side MOSFET (N1), the worst-case power dissipation always occurs at maximum input voltage:

$$PD(N1) = \left[1 - \left(\frac{V_{BATT}}{V_{DCIN}} \right) \right] \left(\frac{I_{LOAD}}{2} \right)^2 \times R_{DS(ON)}$$

Choose a Schottky diode (D1, Figure 2) with a forward voltage low enough to prevent the N1 MOSFET body diode from turning on during the dead time. As a general rule, a diode with a DC current rating equal to 1/3rd the load current is sufficient. This diode is optional and can be removed if efficiency is not critical.

Inductor Selection

The charge current, ripple, and operating frequency (off-time) determine the inductor characteristics. Inductor L1 must have a saturation current rating of at least the maximum charge current plus 1/2 of the ripple current (ΔI_L):

$$I_{SAT} = I_{CHG} + (1/2) \Delta I_L$$

Multichemistry Battery Chargers with Automatic System Power Selector

The ripple current is determined by:

$$\Delta I_L = V_{BATT} t_{OFF} / L$$

where:

$$t_{OFF} = 2.5\mu s (V_{DCIN} - V_{BATT}) / V_{DCIN} \text{ for } V_{BATT} < 0.88 V_{DCIN}$$

or:

$$t_{OFF} = 0.3\mu s \text{ for } V_{BATT} > 0.88 V_{DCIN}$$

Figure 11 illustrates the variation of the ripple current vs. battery voltage when the circuit is charging at 3A with a fixed input voltage of 19V.

Higher inductor values decrease the ripple current. Smaller inductor values require high-saturation current capabilities and degrade efficiency. Designs that set $LIR = \Delta I_L / I_{CHG} = 0.3$ usually result in a good balance between inductor size and efficiency.

Input-Capacitor Selection

The input capacitor must meet the ripple current requirement (I_{RMS}) imposed by the switching currents. Nontantalum chemistries (ceramic, aluminum, or OS-CON) are preferred due to their resilience to power-up surge currents.

$$I_{RMS} = I_{CHG} \left(\frac{\sqrt{V_{BATT}(V_{DCIN} - V_{BATT})}}{V_{DCIN}} \right)$$

The input capacitors should be sized so that the temperature rise due to ripple current in continuous conduction does not exceed approximately 10°C. The maximum ripple current occurs at 50% duty factor or $V_{DCIN} = 2 \times V_{BATT}$, which equates to $0.5 \times I_{CHG}$. If the application of interest does not achieve the maximum value, size the input capacitors according to the worst-case conditions.

Output-Capacitor Selection

The output capacitor absorbs the inductor ripple current and must tolerate the surge current delivered from the battery when it is initially plugged into the charger. As such, both capacitance and ESR are important parameters in specifying the output capacitor as a filter and to ensure the stability of the DC-DC converter (see the *Compensation* section). Beyond the stability requirements, it is often sufficient to make sure that the output capacitor's ESR is much lower than the battery's ESR. Either tantalum or ceramic capacitors can be used on the output. Ceramic devices are preferable because of their good voltage ratings and resilience to surge currents.

Applications Information

Startup Conditioning Charge for Overdischarged Cells

It is desirable to charge deeply discharged Li+ batteries at a low rate to improve cycle life. The MAX1909/MAX8725 automatically reduces the charge current when the voltage per cell is below 3.1V. The charge current-sense voltage is set to 4.5mV ($I_{CHG} = 300\text{mA}$ with $R_{S2} = 15\text{m}\Omega$) until the battery voltage rises above the threshold. There is approximately 300mV for 3 cell, 400mV for 4 cell of hysteresis to prevent the charge-current magnitude from chattering between the two values.

For the MAX8725, control the ICTL voltage to set a conditioning charge rate.

Layout and Bypassing

Bypass DCIN with a 1 μ F capacitor to ground (Figure 1). D4 protects the MAX1909/MAX8725 when the DC power source input is reversed. A signal diode for D4 is adequate because DCIN only powers the LDO and the internal reference. Bypass LDO, DHIV, DLOV, and other pins as shown in Figure 1.

Good PC board layout is required to achieve specified noise, efficiency, and stable performance. The PC board layout artist must be given explicit instructions—preferably, a sketch showing the placement of the power-switching components and high-current routing. Refer to the PC board layout in the MAX1909/MAX8725 evaluation kit for examples. A ground plane is essential for optimum performance. In most applications, the circuit is located on a multilayer board, and full use of the four or more copper layers is recommended. Use the top layer for high-current connections, the bottom layer for quiet connections, and the inner layers for an uninterrupted ground plane.

Use the following step-by-step guide:

- 1) Place the high-power connections first, with their grounds adjacent:
 - a) Minimize the current-sense resistor trace lengths, and ensure accurate current sensing with Kelvin connections.
 - b) Minimize ground trace lengths in the high-current paths.
 - c) Minimize other trace lengths in the high-current paths.
 - d) Use >5mm wide traces.

Multichemistry Battery Chargers with Automatic System Power Selector

MAX1909/MAX8725

- e) Connect C1 and C2 to the high-side MOSFET (10mm max length). Return these capacitors to the power ground plane.
- f) Minimize the LX node (MOSFETs, rectifier cathode, inductor (15mm max length)).

Ideally, surface-mount power components are flush against one another with their ground terminals almost touching. These high-current grounds are then connected to each other with a wide, filled zone of top-layer copper, so they do not go through vias.

The resulting top-layer ground plane is connected to the normal inner-layer ground plane at the output ground terminals, which ensures that the IC's analog ground is sensing at the supply's output terminals without interference from IR drops and ground noise. Other high-current paths should also be minimized, but focusing primarily on short ground and current-sense connections eliminates about 90% of all PC board layout problems.

- 2) Place the IC and signal components. Keep the main switching node (LX node) away from sensitive analog components (current-sense traces and REF capacitor). **Important: the IC should be less than 10mm from the current-sense resistors.**

Quiet connections to REF, VCTL, ICTL, CCV, CCI, CCS, IINP, ACIN, and DCIN should be returned to a separate ground (GND) island. The appropriate traces are marked on the schematic with the ground symbol (\perp). There is very little current flowing in these traces, so the ground island need not be very large. When placed on an inner layer, a sizable ground island can help simplify the layout because the low-current connections can be made through vias. The ground pad on the backside of the package should also be connected to this quiet ground island.

- 3) Keep the gate drive traces (DHI and DLO) as short as possible ($L < 20\text{mm}$), and route them away from the current-sense lines and REF. These traces should also be relatively wide ($W > 1.25\text{mm}$).
- 4) Place ceramic bypass capacitors close to the IC. The bulk capacitors can be placed further away.
- 5) Use a single-point star ground placed directly below the part at the PGND pin. Connect the power ground (ground plane) and the quiet ground island at this location. See Figure 12.

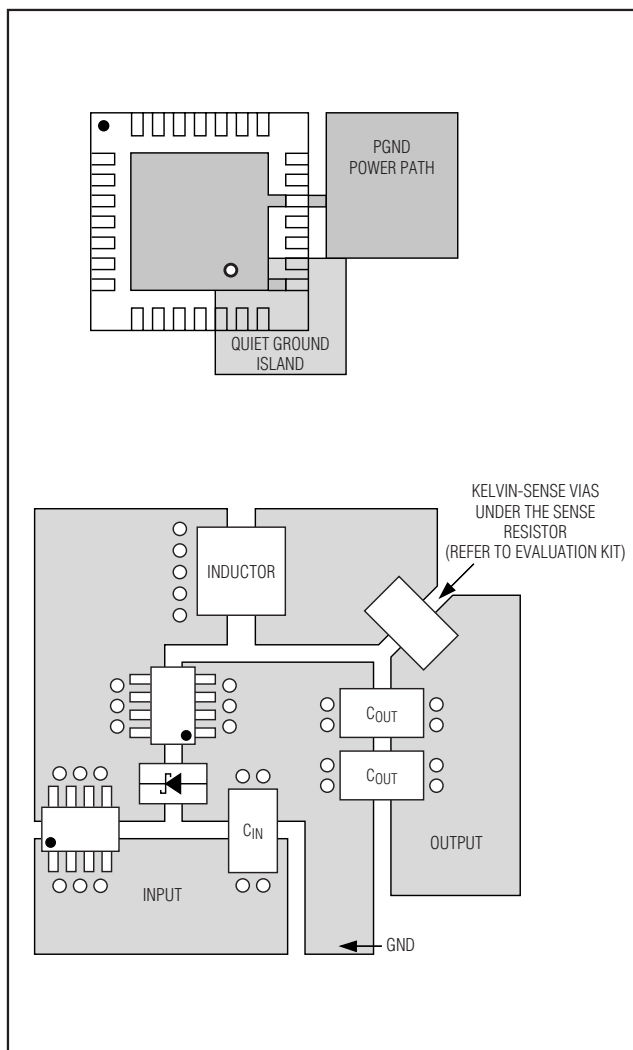

Figure 12. PC Board Layout Examples

Chip Information

TRANSISTOR COUNT: 2720

PROCESS: BiCMOS

Multichemistry Battery Chargers with Automatic System Power Selector

Package Information

(The package drawing(s) in this data sheet may not reflect the most current specifications. For the latest package outline information, go to www.maxim-ic.com/packages.)

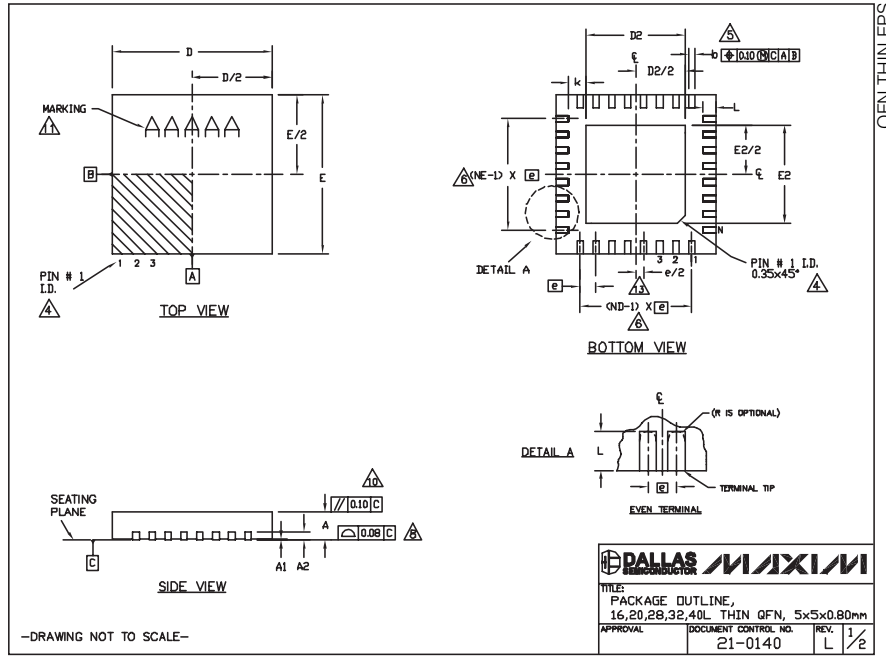

NOTES:

- DIMENSIONING & TOLERANCING CONFORM TO ASME Y14.5M-1994.
- ALL DIMENSIONS ARE IN MILLIMETERS. ANGLES ARE IN DEGREES.
- N IS THE TOTAL NUMBER OF TERMINALS.
- THE TERMINAL #1 IDENTIFIER AND TERMINAL NUMBERING CONVENTION SHALL CONFORM TO JEDEC 95-1 SPP-012. DETAILS OF TERMINAL #1 IDENTIFIER ARE OPTIONAL, BUT MUST BE LOCATED WITHIN THE ZONE INDICATED. THE TERMINAL #1 IDENTIFIER MAY BE EITHER A MOLD OR MARKED FEATURE.
- DIMENSION b APPLIES TO METALLIZED TERMINAL AND IS MEASURED BETWEEN 0.25 mm AND 0.30 mm FROM TERMINAL TIP.
- ND AND NE REFER TO THE NUMBER OF TERMINALS ON EACH D AND E SIDE RESPECTIVELY.
- DEPOPULATION IS POSSIBLE IN A SYMMETRICAL FASHION.
- COPLANARITY APPLIES TO THE EXPOSED HEAT SINK SLUG AS WELL AS THE TERMINALS.
- DRAWING CONFORMS TO JEDEC M0220, EXCEPT EXPOSED PAD DIMENSION FOR T2855-3, T2855-6, T4055-1 AND T4055-2.
- WARPAGE SHALL NOT EXCEED 0.10 mm.
- MARKING IS FOR PACKAGE ORIENTATION REFERENCE ONLY.
- NUMBER OF LEADS SHOWN ARE FOR REFERENCE ONLY.
- LEAD CENTERLINES TO BE AT TRUE POSITION AS DEFINED BY BASIC DIMENSION 'e', ±0.05.
- ALL DIMENSIONS APPLY TO BOTH LEADED AND P/BFREE PARTS.

PACKAGE OUTLINE, 16,20,28,32,40L THIN QFN, 5x5x0.80mm

APPROVAL: [Signature] DOCUMENT CONTROL NO. 21-0140 REV. L 1/2

Maxim cannot assume responsibility for use of any circuitry other than circuitry entirely embodied in a Maxim product. No circuit patent licenses are implied. Maxim reserves the right to change the circuitry and specifications without notice at any time.