



RECTRON

SEMICONDUCTOR

TECHNICAL SPECIFICATION

**GMZJ
Series**

Micro MELF ZENER DIODE 2.5% 500mW

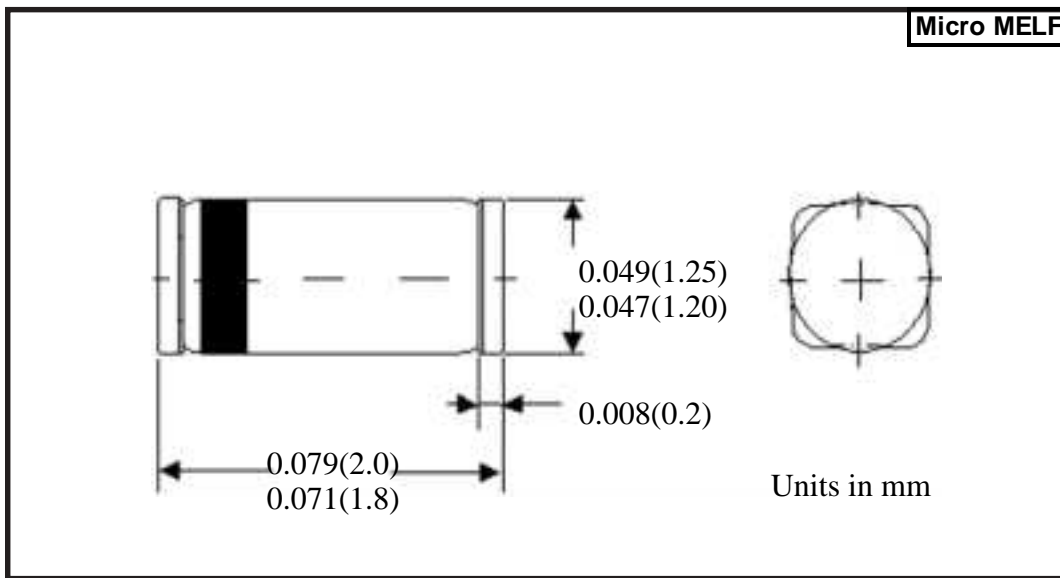

Absolute Maximun Ratings (Ta=25°C)

	Symbol	Value	Unit
Zener Current see Table "Characteristics"			
Power Dissipation at Tamb=25°C	Ptot	500*	mW
Junction Temperature	Tj	175	°C
Storage Temperature Range	Ts	-65 to +175	°C

Characteristic at Tamb=25°C

	Symbol	Min.	Typ.	Max.	Unit
Thermal Resistance	RthA	-	-	0.3*	K/mW
Junction to Ambient Air					
Forward Voltage	VF	-	-	1	V
at IF=100mA					

*Valid provided that leads at a distance of 10mm from case are kept at ambient temperature.

Electrical Characteristics Ta = 25°C

TYPE	CLASS	V _Z (V)		I _Z (mA)	I _F (mA)	V _F (V)		V _R (V)	I _R (uA) MAX	I _{ZT} (mA)	Zzt(W) MAX	Izk (mA)	Zzk(W) MAX
		MIN	MAX			MIN	MAX						
GMZ J 2.0	A	1.88	2.10	5	100	0.2	1.0	0.5	120	5	100	0.5	1000
	B	2.02	2.20										
GMZ J 2.2	A	2.12	2.30	5	100	0.2	1.0	0.7	100	5	100	0.5	1000
	B	2.22	2.41										
GMZ J 2.4	A	2.33	2.52	5	100	0.2	1.0	1.0	120	5	100	0.5	1000
	B	2.43	2.63										
GMZ J 2.7	A	2.54	2.75	5	100	0.2	1.0	1.0	100	5	110	0.5	1000
	B	2.69	2.91										
GMZ J 3.0	A	2.85	3.07	5	100	0.2	1.0	1.0	50	5	120	0.5	1000
	B	3.01	3.22										
GMZ J 3.3	A	3.16	3.38	5	100	0.2	1.0	1.0	20	5	120	0.5	1000
	B	3.32	3.53										
GMZ J 3.6	A	3.46	3.69	5	100	0.2	1.0	1.0	10	5	100	1	1000
	B	3.60	3.84										
GMZ J 3.9	A	3.74	4.01	5	100	0.2	1.0	1.0	5	5	100	1	1000
	B	3.89	4.16										
GMZ J 4.3	A	4.04	4.29	5	100	0.2	1.0	1.0	5	5	100	1	1000
	B	4.17	4.43										
	C	4.30	4.57										
GMZ J 4.7	A	4.44	4.68	5	100	0.2	1.0	1.0	5	5	90	1	900
	B	4.55	4.80										
	C	4.68	4.93										
GMZ J 5.1	A	4.81	5.07	5	100	0.2	1.0	1.5	5	5	80	1	800
	B	4.94	5.20										
	C	5.09	5.37										
GMZ J 5.6	A	5.28	5.55	5	100	0.2	1.0	2.5	5	5	60	1	500
	B	5.45	5.73										
	C	5.61	5.91										
GMZ J 6.2	A	5.78	6.09	5	100	0.2	1.0	3.0	5	5	60	1	300
	B	5.96	6.27										
	C	6.12	6.44										
GMZ J 6.8	A	6.29	6.63	5	100	0.2	1.0	3.5	2	5	20	0.5	150
	B	6.49	6.83										
	C	6.66	7.01										
GMZ J 7.5	A	6.85	7.22	5	100	0.2	1.0	4.0	0.5	5	20	0.5	120
	B	7.07	7.45										
	C	7.29	7.67										
GMZ J 8.2	A	7.53	7.92	5	100	0.2	1.0	5.0	0.5	5	20	0.5	120
	B	7.78	8.19										
	C	8.03	8.45										
GMZ J 9.1	A	8.29	8.73	5	100	0.2	1.0	6.0	0.5	5	25	0.5	120
	B	8.57	9.01										
	C	8.83	9.30										
GMZ J 10	A	9.12	9.59	5	100	0.2	1.0	7.0	0.2	5	30	0.5	120
	B	9.41	9.90										
	C	9.70	10.20										

Electrical Characteristics Ta = 25°C

TYPE	CLASS	V _Z (V)		I _Z (mA)	I _F (mA)	V _F (V)		V _R (V)	I _R (μ A) MAX	I _{ZT} (mA)	Z _{ZT} (W) MAX	I _{ZK} (mA)	Z _{ZK} (W) MAX
		MIN	MAX			MIN	MAX						
GMZ J 11	A	10.18	10.71	5	100	0.2	1.0	8.0	0.2	5	30	0.5	120
	B	10.50	11.05										
	C	10.82	11.38										
GMZ J 12	A	11.13	11.71	5	100	0.2	1.0	9.0	0.2	5	30	0.5	110
	B	11.44	12.03										
	C	11.74	12.35										
GMZ J 13	A	12.11	12.75	5	100	0.2	1.0	10.0	0.2	5	35	0.5	110
	B	12.55	13.21										
	C	12.99	13.66										
GMZ J 15	A	13.44	14.13	5	100	0.2	1.0	11.0	0.2	5	40	0.5	110
	B	13.89	14.62										
	C	14.35	15.09										
GMZ J 16	A	14.80	15.57	5	100	0.2	1.0	12.0	0.2	5	40	0.5	150
	B	15.25	16.04										
	C	15.69	16.51										
GMZ J 18	A	16.22	17.06	5	100	0.2	1.0	13.0	0.2	5	45	0.5	150
	B	16.82	17.70										
	C	17.42	18.33										
GMZ J 20	A	18.02	18.96	5	100	0.2	1.0	15.0	0.2	5	55	0.5	200
	B	18.63	19.59										
	C	19.23	20.22										
	D	19.72	20.72										
GMZ J 22	A	20.15	21.20	5	100	0.2	1.0	17.0	0.2	5	30	0.5	200
	B	20.64	21.71										
	C	21.08	22.17										
	D	21.52	22.63										
GMZ J 24	A	22.05	23.18	5	100	0.2	1.0	19.0	0.2	5	35	0.5	200
	B	22.61	23.77										
	C	23.12	24.31										
	D	23.63	24.85										
GMZ J 27	A	24.26	25.52	5	100	0.2	1.0	21.0	0.2	5	45	0.5	250
	B	24.97	26.26										
	C	25.63	26.95										
	D	26.29	27.64										
GMZ J 30	A	26.99	28.39	5	100	0.2	1.0	23.0	0.2	5	55	0.5	250
	B	27.70	29.13										
	C	28.36	29.82										
GMZ J 33	A	29.68	31.22	5	100	0.2	1.0	25.0	0.2	5	65	0.5	250
	B	30.32	31.88										
	C	30.90	32.50										
	D	31.49	33.11										
GMZ J 36	A	32.14	33.79	5	100	0.2	1.0	27.0	0.2	5	75	0.5	250
	B	32.79	34.49										
	C	33.40	35.13										
	D	34.01	35.77										
GMZ J 39	A	34.68	36.47	5	100	0.2	1.0	30.0	0.2	5	85	0.5	250
	B	35.36	37.19										
	C	36.00	37.85										
	D	36.63	38.52										