

EVALUATION KIT AVAILABLE**MAXIM**

Simple, Efficient, 1-Cell Li+ Pulse Charger

MAX1879

General Description

The MAX1879 single-cell lithium-ion (Li+) battery charger utilizes an efficient pulse-charging architecture to minimize power dissipation in portable devices. This architecture combines the efficiency of switch-mode chargers with the simplicity and low cost of linear chargers. This simple device, in conjunction with a current-limited wall cube and a PMOS transistor, allows safe and fast charging of a single Li+ cell.

The MAX1879 initiates charging in one of three ways: battery insertion, charger power-up, or toggling the THERM pin. Key safety features include continuous voltage and temperature monitoring, a preset charger time-out, and an 8mA precharge current mode to charge near-dead cells. Automatic detection of input power removal shuts down the device, minimizing current drain from the battery. An overall system accuracy of 0.75% ensures that the cell capacity is fully utilized without cycle life degradation.

The MAX1879 is offered in a space-saving 8-pin μ MAX package. An evaluation kit (MAX1879EVKIT) is available to help reduce design time.

Applications

Single-Cell Li+ Powered Portables
Self-Charging Battery Packs
PDAs
Cell Phones
Cradle Chargers

Pin Configuration

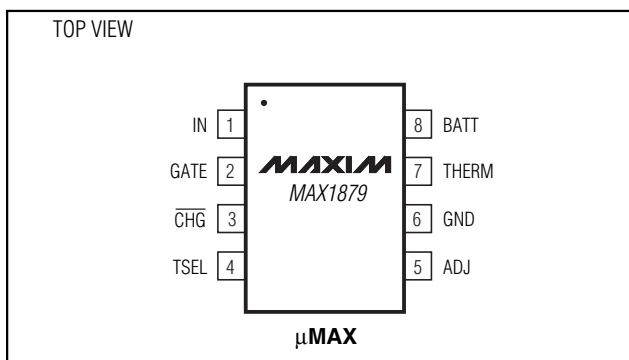

Features

- ◆ Simple Design Minimizes Heat
- ◆ Low Component Count, No Inductor
- ◆ Battery-Full Indicator
- ◆ 0.75% Accurate Battery Regulation
- ◆ 1.5 μ A (max) Battery Current Drain with Wall Cube Removed
- ◆ Restart Charging at 4.0V
- ◆ Continuous Overvoltage and Overtemperature Protection
- ◆ Safely Precharges Near-Dead Cells
- ◆ Automatic Power-Down when Power Source is Removed
- ◆ Charges 1 Cell from as Low as 4.5V
- ◆ Pin-Compatible Upgrade to MAX1679

Ordering Information

PART	TEMP. RANGE	PIN-PACKAGE
MAX1879EUA	-40°C to +85°C	8- μ MAX

Typical Operating Circuit

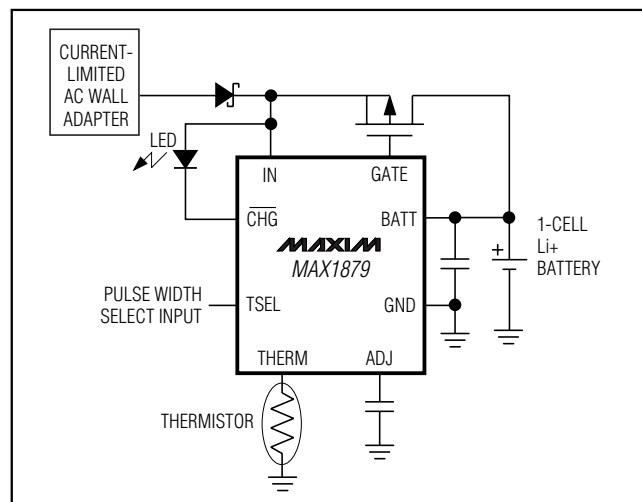
**MAXIM**

Maxim Integrated Products 1

For pricing, delivery, and ordering information, please contact Maxim/Dallas Direct! at 1-888-629-4642, or visit Maxim's website at www.maxim-ic.com.

Simple, Efficient, 1-Cell Li+ Pulse Charger

ABSOLUTE MAXIMUM RATINGS

IN, $\overline{\text{CHG}}$, GATE to GND.....	-0.3V to +26V	Continuous Power Dissipation ($T_A = +70^\circ\text{C}$)
BATT, TSEL, THERM, ADJ to GND.....	-0.3V to +6V	8-Pin μMAX (derate 4.1mW/ $^\circ\text{C}$ above $+70^\circ\text{C}$)
GATE to IN.....	-6V to +0.3V	330mW
THERM, ADJ to BATT.....	-6V to +0.3V	Operating Temperature Range
GATE Continuous Current	-10mA	-40 $^\circ\text{C}$ to +85 $^\circ\text{C}$
		Storage Temperature Range
		-65 $^\circ\text{C}$ to +150 $^\circ\text{C}$
		Lead Temperature (soldering, 10s)
		+300 $^\circ\text{C}$

Stresses beyond those listed under "Absolute Maximum Ratings" may cause permanent damage to the device. These are stress ratings only, and functional operation of the device at these or any other conditions beyond those indicated in the operational sections of the specifications is not implied. Exposure to absolute maximum rating conditions for extended periods may affect device reliability.

ELECTRICAL CHARACTERISTICS

($V_{\text{IN}} = V_{\overline{\text{CHG}}} = +10\text{V}$, $V_{\text{BATT}} = +4.2\text{V}$, TSEL = GND, GATE = unconnected, ADJ = unconnected, THERM = 10k Ω to GND, $T_A = 0^\circ\text{C}$ to +85 $^\circ\text{C}$, unless otherwise noted. Typical values are at $T_A = +25^\circ\text{C}$.)

PARAMETER	SYMBOL	CONDITIONS	MIN	TYP	MAX	UNITS
Input Voltage (Note 1)	V_{IN}	External PMOS FET off	4.4		22	V
Undervoltage Lockout Trip Point		BATT rising	2.1	2.2	2.3	V
Undervoltage Lockout Trip-Point Hysteresis		BATT falling		60		mV
Fast-Charge Qualification Threshold		BATT rising, transition from precharge to full current	2.425	2.5	2.575	V
Fast-Charge Restart Threshold		BATT falling, transition from Done to Prequalification state (Note 2)	3.92	4.00	4.08	V
Fast-Charge Reset Threshold Delay		(Note 3)		1		ms
Precharge Source Current		$V_{\text{BATT}} = 2\text{V}$	5	8	12	mA
BATT Regulation Voltage			4.1685	4.2000	4.2315	V
BATT Regulation Adjust Range			4.0		4.2	V
ADJ Source Impedance			9.8	10	10.2	k Ω
ADJ Output Voltage		No load on ADJ	1.393	1.400	1.407	V
BATT Removal Detection Threshold		BATT rising	4.875	5	5.125	V
BATT Removal Detection Threshold Hysteresis		BATT falling		125		mV
BATT Input Current (Note 4)		$V_{\text{IN}} \leq V_{\text{BATT}} - 0.3\text{V}$		0.1	1.5	μA
BATT Input Current, Fast-Charge State	I_{BATT}	$V_{\text{BATT}} = 4.0\text{V}$		900	1500	μA
BATT Input Current, Done State	I_{BATT}	$V_{\text{BATT}} = 4.25\text{V}$, V_{IN} present		85	200	μA
IN Input Current, Fast-Charge State	I_{IN}	$V_{\text{BATT}} = 4.0\text{V}$, $V_{\text{IN}} = 4.0\text{V}$		50	500	μA
IN Input Current, Done State	I_{IN}	$V_{\text{BATT}} = 4.25\text{V}$, $V_{\text{IN}} = 22\text{V}$		700	1200	μA
Timer Accuracy			-10		+10	%
$\overline{\text{CHG}}$ Output Leakage Current		$V_{\overline{\text{CHG}}} = 22\text{V}$, $\overline{\text{CHG}} = \text{high}$	-1		+1	μA
$\overline{\text{CHG}}$ Output Sink Current		$V_{\overline{\text{CHG}}} = 1.0\text{V}$, $\overline{\text{CHG}} = \text{low}$	4	5	6	mA

Simple, Efficient, 1-Cell Li+ Pulse Charger

MAX1879

ELECTRICAL CHARACTERISTICS (continued)

($V_{IN} = V_{CHG} = +10V$, $V_{BATT} = +4.2V$, TSEL = GND, GATE = unconnected, ADJ = unconnected, THERM = 10k Ω to GND, $T_A = 0^\circ C$ to $+85^\circ C$, unless otherwise noted. Typical values are at $T_A = +25^\circ C$.)

PARAMETER	SYMBOL	CONDITIONS	MIN	TYP	MAX	UNITS
THERM Sense Current (for hot qualification)			346	352.9	360	μA
THERM Sense Current (for cold qualification)			47.8	48.8	49.8	μA
THERM Sense Voltage Trip Point			1.379	1.40	1.421	V
GATE Source Current		$V_{IN} = 10V$, $V_{GATE} = 8V$	75	100	125	μA
GATE Sink Current		$V_{IN} = 10V$, $V_{GATE} = 8V$	19	25	31	μA
GATE Drive Current at Battery Removal		$V_{BATT} = 5.1V$, gate driven high	18	40	60	mA

ELECTRICAL CHARACTERISTICS

($V_{IN} = V_{CHG} = +10V$, $V_{BATT} = +4.2V$, TSEL = GND, GATE = unconnected, ADJ = unconnected, THERM = 10k Ω to GN, $T_A = -40^\circ C$ to $+85^\circ C$, unless otherwise noted.) (Note 5)

PARAMETER	SYMBOL	CONDITIONS	MIN	MAX	UNITS
Input Voltage (Note 1)	V_{IN}	External PMOS FET off	4.6	22	V
Undervoltage Lockout Trip Point		BATT rising	2.05	2.35	V
Fast-Charge Qualification Threshold		BATT rising, transition from precharge to full current	2.35	2.65	V
Fast-Charge Restart Threshold		BATT falling, transition from Done to Prequalification state (Note 2)	3.88	4.12	V
Precharge Source Current		$V_{BATT} = 2V$	4.5	12	mA
BATT Regulation Voltage			4.137	4.263	V
BATT Regulation Adjust Range			4.0	4.2	V
ADJ Source Impedance			9.8	10.2	k Ω
ADJ Output Voltage		No load on ADJ	1.383	1.417	V
BATT Removal Detection Threshold		BATT rising	4.85	5.15	V
BATT Input Current (Note 4)		$V_{IN} \leq V_{BATT} - 0.3V$		1.5	μA
BATT Input Current, Fast-Charge State	I_{BATT}	$V_{BATT} = 4.0V$		1500	μA
BATT Input Current, Done State	I_{BATT}	$V_{BATT} = 4.25V$, V_{IN} present		300	μA
IN Input Current, Fast-Charge State	I_{IN}	$V_{BATT} = 4.0V$, $V_{IN} = 4.0V$		600	μA
IN Input Current, Done State	I_{IN}	$V_{BATT} = 4.25V$, $V_{IN} = 22V$		1500	μA
CHG Output Leakage Current		$V_{CHG} = 22V$, $\overline{CHG} = \text{high}$	-1	+1	μA
CHG Output Sink Current		$V_{CHG} = 1.0V$, $\overline{CHG} = \text{low}$	4	6	mA

Simple, Efficient, 1-Cell Li+ Pulse Charger

ELECTRICAL CHARACTERISTICS (continued)

($V_{IN} = V_{CHG} = +10V$, $V_{BATT} = +4.2V$, TSEL = GND, GATE = unconnected, ADJ = unconnected, THERM = 10k Ω to GND, $T_A = -40^{\circ}C$ to $+85^{\circ}C$, unless otherwise noted.) (Note 5)

PARAMETER	SYMBOL	CONDITIONS	MIN	MAX	UNITS
THERM Sense Current (for hot qualification)			342	363	μA
THERM Sense Current (for cold qualification)			47.3	50.3	μA
THERM Sense Voltage Trip Point			1.358	1.442	V
GATE Source Current		$V_{IN} = 10V$, $V_{GATE} = 8V$	60	140	μA
GATE Sink Current		$V_{IN} = 10V$, $V_{GATE} = 8V$	15	35	μA
GATE Drive Current at Battery Removal		$V_{BATT} = 5.1V$, gate driven high	15	90	mA

Note 1: The input voltage range is specified with the external PMOS FET off. When charging, the PMOS FET turns on, and the input voltage (the output voltage of the current-limited source) drops to very near the battery voltage. When the PFET is on, V_{IN} may be as low as 2.5V.

Note 2: Restart Threshold tracks battery regulation voltage adjustment.

Note 3: Glitches less than 1ms do not cause a restart.

Note 4: This current is less than 1.5 μA , even if an external R_{ADJ} resistor is connected from ADJ to GND.

Note 5: Specifications to $-40^{\circ}C$ are guaranteed by design and not production tested.

Simple, Efficient, 1-Cell Li+ Pulse Charger

MAX1879

Typical Operating Characteristics

($V_{IN} = \overline{CHG} = +10V$, $V_{BATT} = +4.2V$, THERM = 10k Ω to GND, $T_A = +25^\circ C$, unless otherwise noted.)

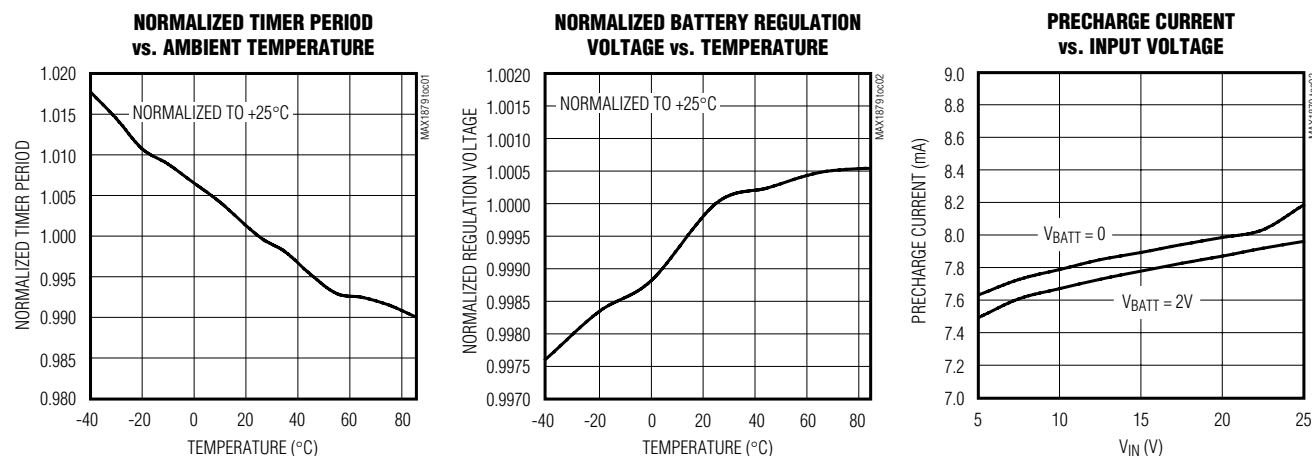

Pin Description

PIN	NAME	FUNCTION
1	IN	Input Voltage from Current-Limited Voltage Source (+22V max). Bypass to GND with a 0.1 μ F capacitor.
2	GATE	Gate Drive for External PMOS Pass Element. The PMOS device should have a V_{GS} threshold less than 2.5V. See <i>Selecting External Components</i> .
3	\overline{CHG}	Charge Status Indication. A \overline{CHG} low indicates that the MAX1879 is charging a battery. \overline{CHG} goes high when the on/off duty cycle falls to 1/8, indicating that the battery is charged to approximately 95% of full capacity. \overline{CHG} is an open-drain current-limited N-channel MOSFET suitable for directly driving an LED. Connect a pullup resistor to the logic supply to generate a logic-level signal. \overline{CHG} blinks at 2Hz during the Prequalification state ($2.2V < V_{BATT} < 2.5V$) and during a temperature fault.
4	TSEL	Minimum ON/OFF Pulse Width Selection (Table 2)
5	ADJ	Battery Regulation Voltage Adjustment. Bypass to GND with a 1000pF capacitor. Connect a resistor from ADJ to GND to reduce the nominal +4.200V regulation set point. See <i>Adjusting the Battery Regulation Voltage</i> .
6	GND	Ground. See <i>Layout Guidelines</i> for information on system grounding. Connect the battery's negative terminal to GND.
7	THERM	Thermistor Temperature-Sensor Input. Connect an NTC thermistor (10k Ω at +25 $^\circ C$) from THERM to GND to allow prequalification of the cell temperature for fast-charge. Replace the thermistor with a 10k Ω resistor if temperature sensing is not required.
8	BATT	Cell Voltage Monitor Input, Precharge Current Output, and MAX1879 Power Source. Connect BATT to the positive terminal of a single Li+ cell. Bypass BATT with a capacitor to ground (1.5 μ F per amp of charge current).

Simple, Efficient, 1-Cell Li+ Pulse Charger

Functional Diagram

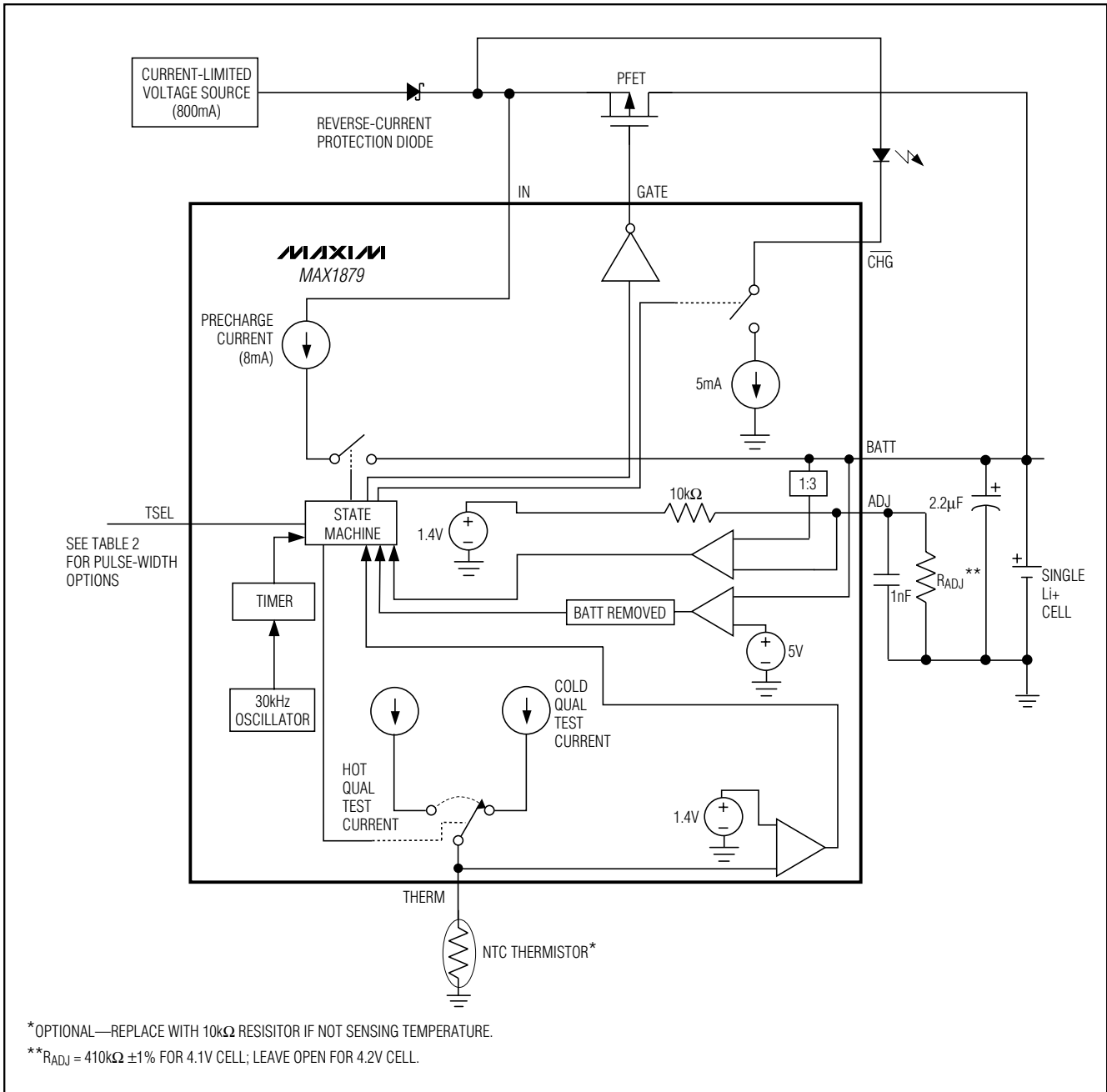

Simple, Efficient, 1-Cell Li+ Pulse Charger

Simplified State Diagram

MAX1879

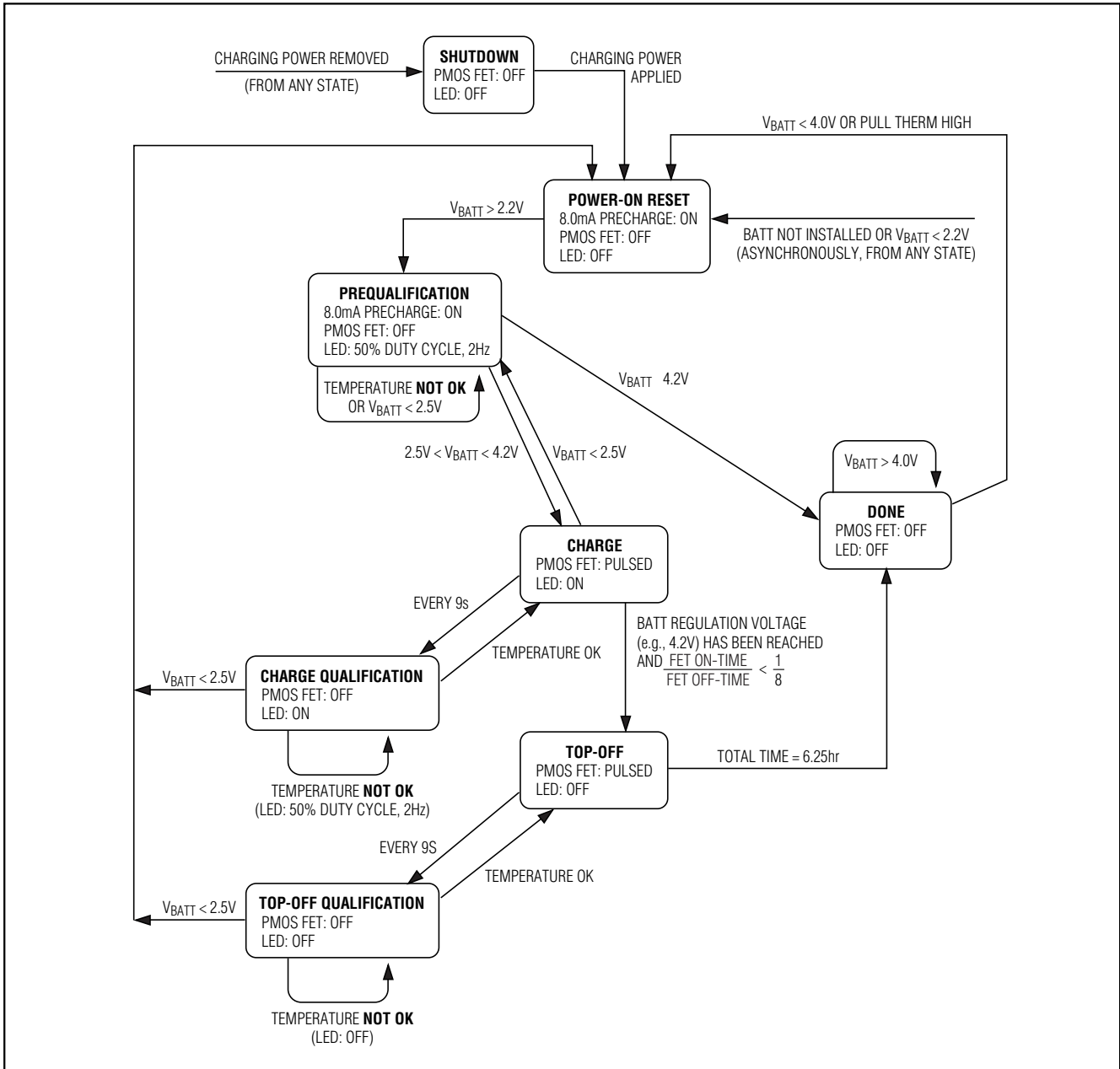

Simple, Efficient, 1-Cell Li+ Pulse Charger

Detailed Description

Initiating a Charge Cycle

The MAX1879 initiates fast-charge upon insertion of a battery or application of an external power source (current-limited AC wall adapter). After charge completion, charging restarts if the cell voltage falls below 4.0V or when THERM is pulled above 1.4V after the charge timer expires (approximately 6.25hr).

Before a charge cycle can begin, cell conditions are verified to be within safe limits. The cell voltage must be greater than 2.5V but less than the regulation voltage (default value 4.2V). In addition, the thermistor must indicate an acceptable cell temperature (default range +2.5°C to +47.5°C). See the *Applications Information* section.

Li+ cells can be damaged when fast-charged from a completely dead state. Moreover, a fully discharged cell may indicate a dangerous abnormal cell condition. As a built-in safety feature, the MAX1879 precharges the Li+ cell with 8mA at the start of a charge cycle if the cell voltage is below 2.5V. As soon as the cell reaches 2.5V and the safety conditions are met (see the *Fast-Charge* section), fast-charging begins.

If the temperature moves outside the programmed range, the charger pauses. When the temperature returns to the safe charging range, the charging cycle continues, and the charge timer resumes counting from the point at which the temperature fault occurred. The timer is not reset. The MAX1879 monitors these conditions throughout the charging cycle.

Fast-Charge

Once cell conditions are determined to be satisfactory, the MAX1879 fast-charges the Li+ cell by pulling GATE low, turning on the external PMOS FET. Cell charging current is set by the current limit of the external power supply; it is not regulated by the MAX1879. The PMOS FET operates only as a switch, not as a linear regulator. Therefore, power dissipation is minimized, permitting rapid charge cycles with minimal heat generation. The external power supply must have a specified current limit that matches the desired fast-charge current for the Li+ cell.

The MAX1879 uses a hysteretic algorithm with minimum on-times and minimum off-times to top-off the cell. The cell voltage is sampled every 2ms. If V_{BATT} is less than the battery regulation voltage, the external PMOS FET turns on or remains on. If the cell voltage is greater than or equal to the battery regulation voltage, the FET turns off and remains off for the minimum off-time. By measuring the cell voltage when the PMOS FET is off as well as when it is on, the MAX1879 eliminates bat-

tery-voltage sensing errors due to charging current flowing through the series resistance of cell protection switches or fuse links in the charging path. Fast-charge continues until the on/off duty cycle falls to 1/8, then the \overline{CHG} LED turns off, indicating that the battery is charged to approximately 95% of full capacity.

Pulsed Top-Off Charge

At the beginning of the Top-Off state, the current stays on for a 1/8 duty cycle. As the cell continues to charge, the percentage of time spent in the "current-on" mode decreases. Towards the end of top-off, the current stays off for many cycles between single "on" pulses. During these final pulses, the instantaneous cell voltage may exceed the battery regulation voltage, but the duration of these pulses is several orders of magnitude shorter than the intrinsic chemical time constant of the Li+ cell. This does not harm the cell. Cell top-off is completed when the charging timer expires (approximately 6.25hr).

Charge Status with \overline{CHG}

\overline{CHG} indicates the cell's charging status. An LED can be connected directly from IN to \overline{CHG} for a visible indicator. Alternatively, a pullup resistor (100k Ω) from a logic supply to \overline{CHG} provides a logic-level output. Table 1 relates the LED status to the charger condition.

Applications Information

The MAX1879 was designed to offer the maximum integration and functionality in the smallest, most basic application circuit possible. The only necessary external components are a current-limited wall cube, a PMOS FET, two small capacitors, and a 10k Ω thermistor/resistor. This simple application circuit appears in Figure 1. Optionally (as shown in Figure 2), an LED can be added as a charge-state indicator, a resistor (R_{ADJ}) can be used to trim down the maximum charge voltage

Table 1. \overline{CHG} Output States

CONDITION	\overline{CHG} (LED)
No battery or no charger, or cell voltage < 2.2V	High impedance (LED off)
Fast-charge in progress	Low (LED on)
Top-Off: on/off duty cycle < 1/8	High impedance (LED off)
Done (charge complete)	High impedance (LED off)
Temperature fault	LED blinks at 2Hz
Prequalification (2.2V < V_{BATT} < 2.5V)	LED blinks at 2Hz

Simple, Efficient, 1-Cell Li+ Pulse Charger

from 4.2V, and/or a reverse-current-protection diode can be added in line at the source.

If the input is shorted, the MAX1879 will not allow current to flow from BATT back through IN to the source. However, the body diode inherent in the enhancement-mode FET would still allow the cell to discharge rapidly. To prevent this, add a power Schottky diode between the source and IN as in Figure 4.

Adjusting the Battery Regulation Voltage

A typical Li+ cell should be charged at a constant current until it reaches a voltage of about 4.2V, then charged at this voltage until the current decays below a predetermined level. The MAX1879 provides a simple way to reduce this maximum target voltage with a single resistor between ADJ and GND. Internally, ADJ connects to a precision 1.4V reference through a 10kΩ resistor. Leave ADJ open for a battery regulation voltage (V_{BR}) of 4.2V; connect a 1% resistor from ADJ to GND to form a voltage-divider for lower battery regulation voltage (V_{BR}'). Select the external value using:

$$R_{ADJ} = \frac{10k\Omega}{\frac{V_{BR}}{V_{BR'}} - 1}$$

A 1% tolerance resistor at ADJ degrades system accuracy by only a fraction of a percent. For example, an R_{ADJ} of 410kΩ ±1% reduces the battery regulation voltage by 2.4% (V_{BR}' = 4.1V from equation above, and (V_{BR}' - V_{BR}) / V_{BR} = (4.1 - 4.2) / 4.2 = -2.4%).

Therefore, the additional system error is simply the R_{ADJ} tolerance multiplied by the percent change in the battery regulation voltage, or (1%)(2.4%) = 0.024%.

Selecting Minimum On-Time

The minimum pulse on-times can be selected by connecting TSEL as indicated in Table 2. A short pulse time may be preferred to minimize voltage overshoot at the battery and prevent pack overvoltage protection circuitry from prematurely activating. A long minimum on-time may be needed when using AC adapters with high turn-on overshoot to allow charging current to settle before the end of the pulse.

Selecting External Components

Power Supply

One reason the MAX1879 Li+ cell-charging solution is so compact and simple is that the charging current is set by the external power source, not by the MAX1879 charging circuit. The PMOS FET in this application circuit is either on or off, allowing the source to be directly connected to the cell or completely disconnected. Therefore, it is very important to choose a power supply

Table 2. TSEL Minimum On-Time Settings

TSEL CONNECTION	MINIMUM ON-TIME IN TOP-OFF (ms)
BATT	34
ADJ	69
GND	137

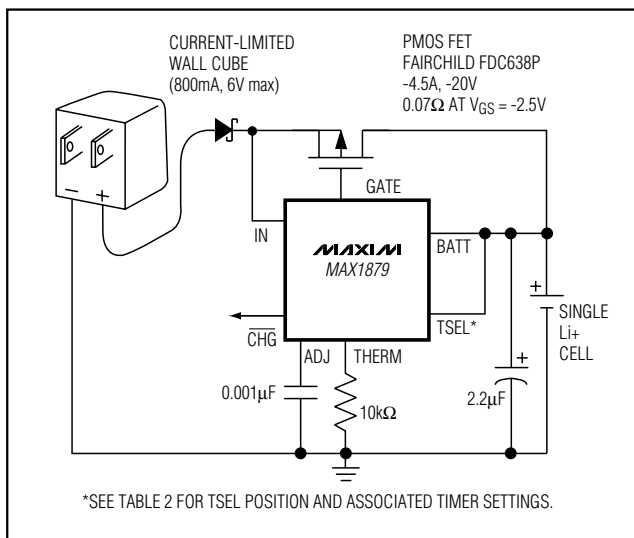

Figure 1. Simple Application Circuit

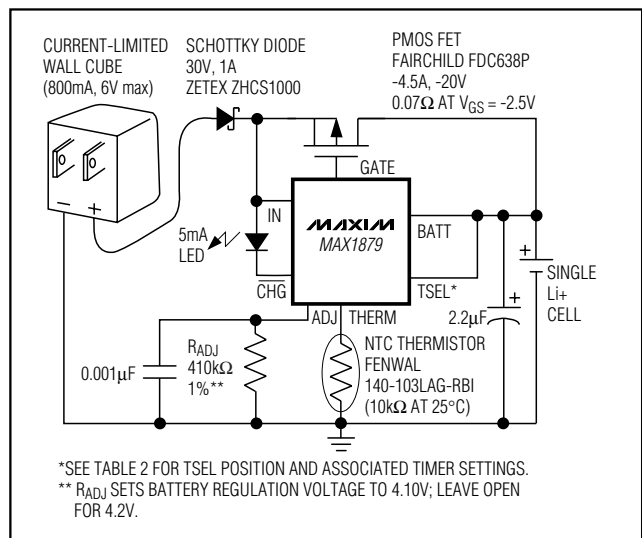

Figure 2. Application Circuit Including LED and Thermistor

Simple, Efficient, 1-Cell Li+ Pulse Charger

with current limiting. In most applications, this will be a small “wall cube” switching converter with an output voltage limit of about 5V or 6V, which is specified as “current-limited” or “constant current.”

PMOS Switch

The PMOS FET switches the current-limited source on and off. Because of the intentionally slow switching times and limited slew rate, the MAX1879 is not particular about the power FET it drives. Specifications to consider when choosing an appropriate FET are the minimum drain-source breakdown voltage, the minimum turn-on threshold voltage (V_{GS}), and current-handling and power-dissipation qualities. The minimum breakdown voltage (BV_{DS}) must exceed the open-circuit voltage of the wall cube by at least 25%. Note that this open-circuit voltage may be twice as high as the specified output voltage, depending on the AC adapter type.

Thermistor

The intent of THERM is to inhibit fast-charging the cell when it is too cold or too hot ($+2.5^{\circ}\text{C} \leq T_{OK} \leq 47.5^{\circ}\text{C}$), using an external thermistor. THERM time multiplexes two sense currents to test for both hot and cold qualification. The thermistor should be $10\text{k}\Omega$ at $+25^{\circ}\text{C}$ and have a negative temperature coefficient (NTC); the THERM pin expects $3.97\text{k}\Omega$ at $+47.5^{\circ}\text{C}$ and $28.7\text{k}\Omega$ at $+2.5^{\circ}\text{C}$. Connect the thermistor between THERM and GND. If no temperature qualification is desired, replace the thermistor with a $10\text{k}\Omega$ resistor. Thermistors by Philips (22322-640-63103), Cornerstone Sensors (T101D103-CA), and Fenwal Electronics (140-103LAG-RB1) work well.

Bypass Capacitors

Bypass the ADJ pin with a 2000pF ceramic capacitor. Bypass BATT with a capacitor with a value of at least $1.5\mu\text{F}$ per amp of charge current. The MAX1879 has a built-in protection feature that prevents BATT from rising above 5.5V. The device recognizes a rapid rise at BATT, indicating that the cell is being removed with the FET on. A capacitor from BATT to GND that's too small does not give the MAX1879 adequate time to shut off the FET. BATT may then rise above 6V (towards the open-circuit source voltage), violating the absolute maximum rating and damaging the device.

In applications where the cell is removable, very large capacitance values make it increasingly difficult to identify momentary cell removal events and may increase transient currents when the cell is replaced. Therefore, values in excess of $100\mu\text{F}$ should be avoided in those cases. For best system performance, at least $0.47\mu\text{F}$ of the total capacitance should be low-ESR ceramic.

Layout Guidelines

The MAX1879 controls the GATE slew rate. The layout is not as sensitive to noise as a high-frequency switching regulator. In addition, since the cell voltage is sensed both during and between high-current pulses, the system is insensitive to ground drops. However, Maxim recommends establishing good grounding areas and large traces for high-current paths.

Chip Information

TRANSISTOR COUNT: 4692

SUBSTRATE CONNECTED TO GND

Simple, Efficient, 1-Cell Li+ Pulse Charger

Package Information

MAX1879

8LUMAXD.EPS

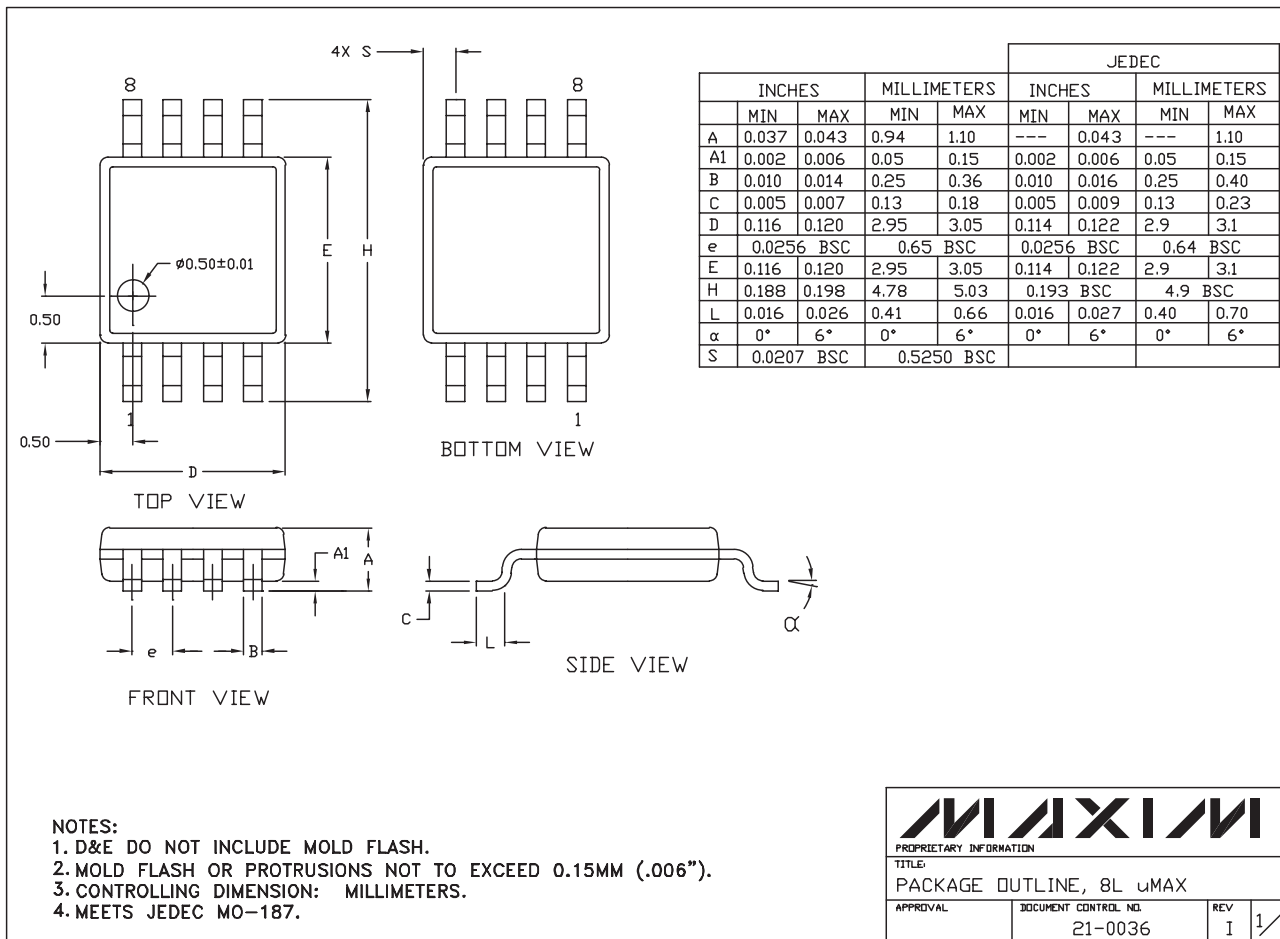

Maxim cannot assume responsibility for use of any circuitry other than circuitry entirely embodied in a Maxim product. No circuit patent licenses are implied. Maxim reserves the right to change the circuitry and specifications without notice at any time.

Maxim Integrated Products, 120 San Gabriel Drive, Sunnyvale, CA 94086 408-737-7600 _____ 11